

Thank you
for purchasing this e-book.

To receive special offers and news
about our latest products,
sign up below.

Or visit LWW.com



FIFTH EDITION

Handbook of Dialysis

Edited by

John T. Daugirdas, MD, FACP, FASN

Clinical Professor of Medicine
University of Illinois at Chicago
Chicago, Illinois

Peter G. Blake, MB, FRCPC, FRCPI

Professor of Medicine
Western University
London, Ontario, Canada

Todd S. Ing, MBBS, FRCP

Professor Emeritus of Medicine
Loyola University Chicago
Maywood, Illinois

 Wolters Kluwer
Health

Philadelphia • Baltimore • New York • London
Buenos Aires • Hong Kong • Sydney • Tokyo

Acquisitions Editor: Julie Goolsby
Product Development Editor: Leanne Vandetty
Editorial Assistant: Brian Convery
Production Project Manager: Bridgett Dougherty
Design Coordinator: Holly Reid McLaughlin
Manufacturing Coordinator: Beth Welsh
Prepress Vendor: S4Carlisle Publishing Services

Fifth Edition

Copyright © 2015 Wolters Kluwer Health

Copyright © 2007 Lippincott Williams & Wilkins, a Wolters Kluwer business. Copyright © 2001 Lippincott Williams & Wilkins. Copyright © 1994, 1988 by J. B. Lippincott. All rights reserved. This book is protected by copyright. No part of this book may be reproduced or transmitted in any form or by any means, including as photocopies or scanned-in or other electronic copies, or utilized by any information storage and retrieval system without written permission from the copyright owner, except for brief quotations embodied in critical articles and reviews. Materials appearing in this book prepared by individuals as part of their official duties as U.S. government employees are not covered by the above-mentioned copyright. To request permission, please contact Wolters Kluwer Health at Two Commerce Square, 2001 Market Street, Philadelphia, PA 19103, via email at permissions@lww.com, or via our website at lww.com (products and services).

9 8 7 6 5 4 3 2 1

Library of Congress Cataloging-in-Publication Data

Handbook of dialysis / [edited by] John T. Daugirdas, Peter G. Blake, Todd S. Ing. — Fifth edition.

p. ; cm.

Includes bibliographical references and index.

ISBN 978-1-4511-4429-1 (paperback)

eISBN 978-1-4698-3086-5

I. Daugirdas, John T., editor. II. Blake, Peter Gerard, 1956- , editor. III. Ing, Todd S., editor.

[DNLM: 1. Renal Dialysis—Handbooks. WJ 39]

RC901.7.H45

617.4'61059—dc23

2014029014

Care has been taken to confirm the accuracy of the information presented and to describe generally accepted practices. However, the author(s), editors, and publisher are not responsible for errors or omissions or for any consequences from application of the information in this book and make no warranty, expressed or implied, with respect to the currency, completeness, or accuracy of the contents of the publication. Application of this information in a particular situation remains the professional responsibility of the practitioner; the clinical treatments described and recommended

may not be considered absolute and universal recommendations.

The author(s), editors, and publisher have exerted every effort to ensure that drug selection and dosage set forth in this text are in accordance with the current recommendations and practice at the time of publication. However, in view of ongoing research, changes in government regulations, and the constant flow of information relating to drug therapy and drug reactions, the reader is urged to check the package insert for each drug for any change in indications and dosage and for added warnings and precautions. This is particularly important when the recommended agent is a new or infrequently employed drug.

Some drugs and medical devices presented in this publication have Food and Drug Administration (FDA) clearance for limited use in restricted research settings. It is the responsibility of the health care provider to ascertain the FDA status of each drug or device planned for use in his or her clinical practice.

LWW.com

To Stanislovas Mačiulis, MD—a beloved
grandfather never met who continues
to guide and inspire.

(JTD)

To my wife Rose and to my sons, Matthew
and Andrew—the three most important
people in my life.

(PB)

To Oliver M. Wrong, MD, FRCP,
my exemplary mentor.

(TSI)

Anil K. Agarwal, MD, FASN, FACP

Professor of Medicine
Ohio State University
Columbus, Ohio

Suhail Ahmad, MD

Professor of Medicine
University of Washington
Seattle, Washington

Michael Allon, MD

Professor of Medicine
University of Alabama at Birmingham
Birmingham, Alabama

Arif Asif, MD, FASN

Professor of Medicine
Albany Medical College
Albany, New York

André Luis Balbi, MD

Assistant Professor of Medicine
São Paulo State University—UNESP
Botucatu, São Paulo, Brazil

Joanne M. Bargman, MD, FRCPC

Professor of Medicine
University of Toronto
Toronto, Ontario, Canada

Susan E. Bentley RD, MBA

Fresenius Medical Care
Waltham, Massachusetts

Peter G. Blake, MB, FRCPC, FRCPI

Professor of Medicine
Western University
London, Ontario, Canada

Neil Boudville, MBBS, FRACP

Senior Lecturer in Renal Medicine

University of Western Australia
Crawley, Australia

Sudhir K. Bowry, PhD

Fresenius Medical Care
Bad Homburg, Germany

Deborah Brouwer-Maier, RN, CNN

Director of Dialysis Access Initiatives
Fresenius Medical Services
Philadelphia, Pennsylvania

Bernard Canaud, MD, PhD

Emeritus Professor of Nephrology
Montpellier University I
Montpellier, France

Ralph J. Caruana, MD, MBA

Professor of Medicine
University of Central Florida
Orlando, Florida

Elliot Michael Charen, MD

Instructor in Medicine
Icahn School of Medicine at Mount Sinai
New York, New York

Horng Ruey Chua, MMed, MRCP

Assistant Professor of Medicine
National University of Singapore
Republic of Singapore

Scott D. Cohen, MD, MPH, FASN

Associate Professor of Medicine
George Washington University
Washington, District of Columbia

Daniel W. Coyne, MD

Professor of Medicine
Washington University
St. Louis, Missouri

John H. Crabtree, MD, FACS

Visiting Clinical Faculty
Harbor-University of California
Los Angeles Medical Center
Torrance, California

Daniel Cukor, PhD

Associate Professor of Psychiatry
SUNY Downstate Medical Center
Brooklyn, New York

John T. Daugirdas, MD, FACP, FASN

Clinical Professor of Medicine
University of Illinois at Chicago
Chicago, Illinois

Andrew Davenport, MA, MD, FRCP

Reader in Medicine and Nephrology
University College of London
London, United Kingdom

James A. Delmez, MD

Professor of Medicine
Washington University
St. Louis, Missouri

Sevag Demirjian, MD

Assistant Professor of Medicine
Cleveland Clinic Lerner College of Medicine
Cleveland, Ohio

Peter B. DeOreo, MD, FACP

Clinical Professor of Medicine
Case Western Reserve University
Cleveland, Ohio

Jose A. Diaz-Buxo, MD, FACP

Interim Medical Office Liaison
Renal Therapies Group
Fresenius Medical Care NA
Charlotte, North Carolina

Mary Ann Emanuele, MD

Professor of Medicine

Loyola University Chicago
Maywood, Illinois

Nicholas Emanuele, MD

Professor of Medicine
Loyola University Chicago
Maywood, Illinois

Fredric O. Finkelstein, MD

Clinical Professor of Medicine
Yale University
New Haven, Connecticut

Steven Fishbane, MD

Professor of Medicine
Hofstra North Shore—Long Island Jewish School of Medicine
Hempstead, New York

Marc Ghannoum, MD

Associate Professor of Medicine
University of Montréal
Montréal, Québec, Canada

Susan Grossman, MD

Associate Professor of Clinical Medicine
New York College of Medicine
Valhalla, New York

Nikolas B. Harbord, MD

Assistant Professor of Medicine
Icahn School of Medicine at Mount Sinai
New York, New York

Olof Heimbürger, MD, PhD

Department of Clinical Science, Intervention, and Technology
Karolinska Institute
Stockholm, Sweden

Joachim Hertel, MD, FACP

Lead Physician
Greenville Kidney Care, LLC
Greenville, South Carolina

Nicholas Hoenich, PhD

Lecturer
Newcastle University
Newcastle upon Tyne, United Kingdom

Susan Hou, MD

Professor of Medicine
Loyola University Chicago
Maywood, Illinois

Priscilla How, PharmD, BCPS

Assistant Professor
Department of Pharmacy
National University of Singapore
Republic of Singapore

T. Alp Ikizler, MD

Professor of Medicine
Vanderbilt University
Nashville, Tennessee

Todd S. Ing, MBBS, FRCP

Professor Emeritus of Medicine
Loyola University Chicago
Maywood, Illinois

Arsh Jain, MD, FRCPC

Assistant Professor of Medicine
Western University
London, Ontario, Canada

Jameela Kari, CABP, MD, CCST, FRCPCH, FRCP (UK)

Professor of Pediatrics
King Abdul Azziz University
Jeddah, Kingdom of Saudi Arabia

Paul L. Kimmel, MD, MACP, FASN

Clinical Professor of Medicine
George Washington University
Washington, District of Columbia

Dobri D. Kiproff, MD, HP

Chief, Division of Immunotherapy

California Pacific Medical Center
San Francisco, California

Kar Neng Lai, MBBS, MD, DSc, FRCP, FRACP, FRCPath

Professor Emeritus of Medicine
University of Hong Kong
Hong Kong, China

Derek S. Larson, MD

Nephrologist
Missouri Baptist Medical Center
St. Louis, Missouri

David J. Leehey, MD

Professor of Medicine
Loyola University Chicago
Maywood, Illinois

Joseph R. Lentino, MD, PhD

Professor of Medicine
Loyola University Chicago
Maywood, Illinois

Philip Kam-Tao Li, MD, FRCP, FACP

Honorary Professor of Medicine
Chinese University of Hong Kong
Hong Kong, China

Robert M. Lindsay, MD, FRCPC, FRCP (Edin), FRCP (Glasg), FACP

Professor of Medicine
Western University
London, Ontario, Canada

Francesca Mallamaci, MD

Professor of Nephrology
Ospedali Riuniti
Reggio Calabria, Italy

Christopher McIntyre, MBBS, DDM

Professor of Medicine
Western University
London, Ontario, Canada

Susan R. Mendley, MD

Associate Professor of Pediatrics and Medicine
University of Maryland
Baltimore, Maryland

Rajnish Mehrotra, MD, MS

Professor of Medicine
University of Washington
Seattle, Washington

Stephen A. Merchant, PhD

Vice President and General Manager
SORB Technology Division
Fresenius Medical Care NA
Oklahoma City, Oklahoma

Jennifer S. Messer, CHT, OCDT, CCNT

Clinical Education Specialist
Department of Critical Care
NxStage Medical, Inc.
Lawrence, Massachusetts

Madhukar Misra, MD, FASN, FACP, FRCP (UK)

Professor of Medicine
University of Missouri
Columbia, Missouri

Gihad E. Nesrallah, MD, FRCPC, FACP

Adjunct Professor of Medicine
Western University
London, Ontario, Canada

Allen R. Nissenson, MD, FACP

Emeritus Professor of Medicine
University of California at Los Angeles
Los Angeles, California
Chief Medical Officer
DaVita Healthcare Partners Inc.
El Segundo, California

Jacqueline T. Pham, PharmD, BCPS

Adjunct Professor
School of Nursing & Health Studies

Georgetown University
Washington, District of Columbia

Andreas Pierratos, MD, FRCPC

Professor of Medicine
University of Toronto
Toronto, Ontario, Canada

Daniela Ponce, MD, PhD

Assistant Professor of Medicine
São Paulo State University—UNESP
Botucatu, São Paulo, Brazil

Charles D. Pusey, DSc, FRCP, FASN, FMCISci

Professor of Medicine
Imperial College London
London, United Kingdom

Michael V. Rocco, MD, MSCE

Professor of Medicine and Public Health Sciences
Wake Forest University
Winston-Salem, North Carolina

Edward A. Ross, MD

Professor of Medicine
University of Central Florida
Orlando, Florida

Loay Salman, MD

Assistant Professor of Clinical Medicine
University of Miami
Miami, Florida

Amber Sanchez, MD

Assistant Clinical Professor of Medicine
University of California, San Diego
San Diego, California

Mark J. Sarnak, MD, MS

Professor of Medicine
Tufts University
Boston, Massachusetts

Hitesh H. Shah, MD

Associate Professor of Medicine
Hofstra North Shore-Long Island Jewish School of Medicine
Hempstead, New York

Richard A. Sherman, MD

Professor of Medicine
Rutgers, The State University of New Jersey
New Brunswick, New Jersey

Ajay Singh, MBBS, FRCP (UK), MBA

Associate Professor of Medicine
Harvard University
Boston, Massachusetts

Stefano Stuard, MD

Director of Clinical Governance – NephroCare
Fresenius Medical Care
Bad Homburg, Germany

Rita S. Suri, MD, Msc, FRCPC, FACP

Associate Professor of Medicine
University of Montréal
Montréal, Québec, Canada

Cheuk-Chun Szeto, MD, FRCP (Edin)

Senior Lecturer in Medicine
Chinese University of Hong Kong
Hong Kong, China

Boon Wee Teo, MB, BCh, BAO, B Med Sci, FACP, FASN

Assistant Professor of Medicine
National University of Singapore
Republic of Singapore

Tran H. Tran, PharmD, BCPS

Assistant Clinical Professor
St. John's University College of Pharmacy and Allied Health Professions
Queens, New York

David Updyke

Fresenius Medical Care
Walnut Creek, California

Tushar J. Vachharajani, MD, FASN, FACP

Professor of Medicine

Edward Via College of Osteopathic Medicine

Spartanburg, South Carolina

Richard A. Ward, PhD

Professor of Nephrology (retired)

University of Louisville

Louisville, Kentucky (Nelson, New Zealand)

Daniel E. Weiner, MD, MS

Associate Professor of Medicine

Tufts University

Boston, Massachusetts

James F. Winchester

Professor of Clinical Medicine

Albert Einstein College of Medicine of Yeshiva University

Bronx, New York

Steven Wu, MD, FASN

Assistant Professor of Medicine

Harvard University

Boston, Massachusetts

Alexander Yevzlin, MD

Associate Professor of Medicine

University of Wisconsin

Madison, Wisconsin

Carmine Zoccali, MD, FASN, FERA

Professor of Nephrology

Director, Center for Clinical Physiology, Renal Diseases and Hypertension of the Italian Research Council

Reggio Calabria, Italy

We are very fortunate and honored to present this Fifth Edition of the *Handbook of Dialysis* to the nephrology community. It has been 7 years since the Fourth Edition; the long interval reflects the relatively slow, incremental nature of improvements that have occurred in dialysis therapy during that period. We continue with a strong international emphasis, referencing both KDOQI and KDIGO guidelines, and taking care to express laboratory measurements in both British Imperial and SI units.

The chapter on online hemodiafiltration, a therapy still not available in the United States, has been maintained and updated. A chapter on sorbent dialysis, present in the first two editions of the *Handbook*, but removed from the third and fourth editions as use of the REDY system dwindled, has been reinstated and modernized, given the anticipated imminent release of new sorbent-equipped machines for both in-center and home hemodialysis. The hemodialysis vascular access section, which grew from one to two chapters between the third and fourth editions, has now expanded to four chapters, testifying to the importance of vascular access to overall hemodialysis patient care. In the peritoneal dialysis section, the access chapter was completely rewritten by a general surgeon with long experience and dedication in this area. Another completely rewritten chapter describes the growing use of acute peritoneal dialysis and “urgent start” PD. For both peritoneal dialysis and hemodialysis adequacy, fewer equations are used and, instead, analogies help explain key concepts. More emphasis is placed on dialysis time, frequency, ultrafiltration rate, and other supplementary metrics of adequacy, including doing dialysis the “European way.” To make room for expanded and additional chapters, a number of topics that were discussed in great detail in their own separate chapters in the Fourth Edition have been downsized and folded into other chapters; our goal was to maintain a pocket-sized book that focuses on frequently encountered clinical problems. As in previous editions, we have tried to maintain the unique character of the *Handbook of Dialysis*, aiming for a resource that will be useful to both new and experienced nephrology care providers to help them in their difficult job of assuring the best treatment for our patients.

We would like to thank the many chapter authors who agreed to write for the *Handbook*. The time demands on clinical nephrologists and other care providers continue to increase, and we greatly appreciate the willingness of our chapter authors to allocate precious time to share their insights and expertise. We would also like to recognize Aleksandra Godlevska for her beautiful modern art-inspired cover design.

John T. Daugirdas
Peter G. Blake
Todd S. Ing

CONTENTS

Contributing Authors
Preface

PART I: CHRONIC KIDNEY DISEASE MANAGEMENT

- 1 Approach to Patients with Chronic Kidney Disease, Stages 1–4
Ajay Singh
- 2 Management of CKD Stages 4 and 5: Preparation for Transplantation, Dialysis, or
Conservative Care
Ajay Singh and Jameela Kari

PART II: BLOOD-BASED THERAPIES

- 3 Physiologic Principles and Urea Kinetic Modeling
John T. Daugirdas
- 4 Hemodialysis Apparatus
Suhail Ahmad, Madhukar Misra, Nicholas Hoenich, and John T. Daugirdas
- 5 Dialysis Water and Dialysate
Richard A. Ward and Todd S. Ing
- 6 Arteriovenous Fistulas and Grafts: The Basics
Tushar J. Vachharajani, Steven Wu, Deborah Brouwer-Maier, and Arif Asif
- 7 Venous Catheter Access: The Basics
Michael Allon and Arif Asif
- 8 Arteriovenous Vascular Access Monitoring and Complications
Alexander Yevzlin, Anil K. Agarwal, Loay Salman, and Arif Asif
- 9 Venous Catheter Infections and Other Complications
Loay Salman, Arif Asif, and Michael Allon
- 10 Acute Hemodialysis Prescription
Edward A. Ross, Allen R. Nissenson, and John T. Daugirdas
- 11 Chronic Hemodialysis Prescription
John T. Daugirdas
- 12 Complications during Hemodialysis
Richard A. Sherman, John T. Daugirdas, and Todd S. Ing

- 13 Dialyzer Reuse
Peter B. DeOreo
- 14 Anticoagulation
Andrew Davenport, Kar Neng Lai, Joachim Hertel, and Ralph J. Caruana
- 15 Continuous Renal Replacement Therapies
Boon Wee Teo, Jennifer S. Messer, Horng Ruey Chua, Priscilla How, and Sevag Demirjian
- 16 Home and Intensive Hemodialysis
Gihad E. Nesrallah, Rita S. Suri, Robert M. Lindsay, and Andreas Pierratos
- 17 Hemodiafiltration
Bernard Canaud, Sudhir Bowry, and Stefano Stuard
- 18 Therapeutic Apheresis
Dobri D. Kiprof, Amber Sanchez, and Charles Pusey
- 19 The Relevance of Sorbent Technology Today
Jose A. Diaz-Buxo, Stephen A. Merchant, David Updyke, and Susan E. Bentley
- 20 Use of Dialysis and Hemoperfusion in the Treatment of Poisoning
James F. Winchester, Nikolas B. Harbord, Elliot Charen, and Marc Ghannoum

PART III: PERITONEAL DIALYSIS

- 21 Physiology of Peritoneal Dialysis
Peter G. Blake and John T. Daugirdas
- 22 Apparatus for Peritoneal Dialysis
Olof Heimbürger and Peter G. Blake
- 23 Peritoneal Dialysis Catheters, Placement, and Care
John H. Crabtree and Arsh Jain
- 24 Peritoneal Dialysis for the Treatment of Acute Kidney Injury
Daniela Ponce, André Luis Balbi, and Fredric O. Finkelstein
- 25 Adequacy of Peritoneal Dialysis and Chronic Peritoneal Dialysis Prescription
Peter G. Blake and John T. Daugirdas
- 26 Volume Status and Fluid Overload in Peritoneal Dialysis
Neil Boudville and Peter G. Blake
- 27 Peritonitis and Exit-Site Infection
Cheuk-Chun Szeto, Philip K.-T. Li, and David J. Leehey
- 28 Hernias, Leaks, and Encapsulating Peritoneal Sclerosis
Joanne M. Bargman
- 29 Metabolic, Acid-Base, and Electrolyte Aspects of Peritoneal Dialysis
Rajnish Mehrotra

PART IV: CLINICAL PROBLEM AREAS

- 30** Psychosocial Issues
Scott D. Cohen, Daniel Cukor, and Paul L. Kimmel
- 31** Nutrition
Michael V. Rocco and T. Alp Ikizler
- 32** Diabetes
David J. Leehey, Mary Ann Emanuele, and Nicholas Emanuele
- 33** Hypertension
Carmine Zoccali and Francesca Mallamaci
- 34** Hematologic Abnormalities
Steven Fishbane and Hitesh H. Shah
- 35** Infections
David J. Leehey, Jacqueline T. Pham, Tran H. Tran, and Joseph R. Lentino
- 36** Bone Disease
Daniel W. Coyne, Derek S. Larson, and James A. Delmez
- 37** Dialysis in Infants and Children
Susan R. Mendley
- 38** Cardiovascular Disease
Daniel E. Weiner and Mark J. Sarnak
- 39** Obstetrics and Gynecology in Dialysis Patients
Susan Hou and Susan Grossman
- 40** Nervous System and Sleep Disorders
Christopher W. McIntyre
- Appendix A:** Tools for Estimating Glomerular Filtration Rate and Daily Creatinine Excretion
- Appendix B:** Nutritional Tools
- Appendix C:** Urea Kinetic Modeling
- Appendix D:** Molecular Weights and Conversion Tables
- Index**

PART I

CHRONIC KIDNEY DISEASE MANAGEMENT

Chronic kidney disease (CKD) can be defined in a variety of ways. The US Preventive Health Service defines it as decreased kidney function, with size-adjusted estimated glomerular filtration rate (eGFR/1.73 m²) <60 mL/min, or as kidney damage that persists for at least 3 months.

The management of a patient with CKD involves the following considerations: screening, etiologic diagnosis, and staging of the CKD severity; identifying and managing patients at high risk of progression; management of complications of CKD; and preparing the patient for transplantation or renal replacement therapy.

I. **SCREENING, DIAGNOSIS, AND STAGING.** Screening should include monitoring for the presence of proteinuria and measurement of kidney function. Screening should focus on patients with CKD risk factors. These include diabetes mellitus, hypertension, cardiovascular disease, history of smoking, obesity, age >60 years, indigenous racial origin, and a family history of CKD.

A. **Urinary protein measurement.** The US Preventive Health Service recommends urinary protein measurement as a screening test in all high-risk individuals. The American Diabetes Association (ADA) recommends that an evaluation for microalbuminuria be performed in all type 2 diabetic patients at the time of diagnosis and in all type 1 diabetic patients 5 years after initial evaluation. Screening can be done by urine dipstick, but a more reliable method is an early morning measurement of the albumin-to-creatinine ratio in a spot urine sample. The dipstick used should be able to detect both albumin and evidence of blood or white cells. If the dipstick test suggests either blood or white cell activity, then a microscopic analysis of the urinary sediment should be performed. Table 1.1 lists several limitations of urine dipstick evaluation. One problem with urine dipstick tests is that they measure concentration only, and can give falsely negative results in a dilute urine. The urine albumin-to-creatinine ratio (UACR) overcomes this problem by looking at the ratio of albumin to creatinine, as both will be affected by dilution, and the effects of dilution will tend to cancel out. In terms of milligrams albumin per gram or millimole of creatinine, normoalbuminuria is defined as <30 mg/g (<3 mg/mmol); microalbuminuria as 30–300 mg/g (3–30 mg/mmol); and macroalbuminuria as >300 mg/g (>30 mg/mmol). These cutoffs correspond only roughly to albuminuria measured in terms of milligrams per day (e.g., 30 and 300 mg per day), and they assume that 1 g of creatinine is being excreted per day. In fact, the average amount of creatinine excreted per day is actually higher, and as discussed elsewhere in this chapter, creatinine excretion is greater in men than in women and in young people versus older people. However, fine-tuning these “cutoff” UACR ratios is not of great clinical importance, as the risk of increased urine albumin excretion is continuous, and risk is increased even when the albumin excretion is <30 mg per day. The UACR can be done at any time, but a morning test may increase sensitivity and will tend to exclude the relatively benign condition of orthostatic proteinuria, where, proteinuria is present during the day, but ceases while the subject is sleeping supine. A positive UACR test should be

repeated at least twice over 3 months to exclude acute kidney injury and to confirm a positive test.

TABLE

1.1

Limitations of Urine Dipstick

False Negatives

Low urine-specific gravity (<1.010)

High urine salt concentration

Acidic urine

Nonalbumin proteinuria

False Positives

Presence of blood or semen

Alkaline urine

Detergents/disinfectants

Radiocontrast agents

High urine-specific gravity (>1.030)

B. Measurement of kidney function

1. **Glomerular filtration rate (GFR).** The GFR, usually expressed in terms of milliliters per minute, is the volume of serum cleared by the kidneys per unit of time. The GFR depends on body size and age, and so an isolated value of GFR needs to be evaluated in context. One usually normalizes GFR to body surface area, specifically, per 1.73 m². In healthy subjects, GFR/1.73 m² is similar in men and women, but GFR/1.73 m² declines with age, averaging about 115 mL/min in young adults, 100 mL/min in the middle-aged, and then dwindling to 90, 80, and 70 mL/min as patient age increases to 60, 70, and 80 years, respectively.
2. **Serum creatinine.** Creatinine is produced at a relatively constant rate from creatine in muscle and is excreted by the kidneys by both glomerular filtration and tubular secretion. Normal creatinine concentrations range from 0.6 to 1.0 mg/dL (53–88 μmol/L) in women and from 0.8 to 1.3 mg/dL (70–115 μmol/L) in men. Measurement of the serum creatinine concentration is one way to obtain a rough estimate of the level of renal function, because as renal function falls, creatinine will continue to be produced, and the serum levels will rise. The relationship between serum creatinine and renal function is nonlinear: a doubling of the serum creatinine will reflect a decline in GFR of approximately 50%. Doubling of serum creatinine from an initially low value can result in a serum creatinine still in the “normal range” despite a substantial loss of kidney function. Serum creatinine levels are influenced by muscle mass, recent dietary intake, especially of cooked meat, and concomitant drug therapy (e.g., treatment with cimetidine, a drug that blocks tubular secretion of creatinine and which will slightly increase the serum creatinine without any effect on GFR). In patients with cirrhosis and ascites, estimation of renal function from serum creatinine is

particularly difficult. There can be a very low creatinine production rate due to extremely low muscle mass (low creatinine production rate), plus it often is difficult to determine ascites-free body weight for normalization. In such patients, serum creatinine levels in the 0.5–1.0-mg/dL range (44–88 $\mu\text{mol/L}$), nominally “normal,” may reflect moderately to markedly impaired levels of renal function. Even in patients without cachexia, the serum creatinine level must always be interpreted in the context of a patient’s muscle mass. For example, a serum creatinine of 1.3 mg/dL (115 $\mu\text{mol/L}$) can represent a creatinine clearance of 94 mL/min in a young 80-kg male, or a creatinine clearance of only 28 mL/min in an elderly, 50-kg female (Macgregor and Methven, 2011).

Until recently the serum creatinine was measured by a variety of methods, some of which, due to interfering substances in the blood, deviated substantially from “true” values of creatinine concentration as determined by isotope dilution mass spectrometry (IDMS). In the United States and many other countries, laboratories are now normalizing their measurement methods to IDMS, and the normalized values tend to be lower than those obtained using other methods.

3. **Creatinine clearance by timed urine collection.** A timed (usually 24 hours) urine collection of creatinine excretion can be used to calculate the creatinine clearance (C_{Cr}), which is defined as the volume of serum cleared of creatinine per minute. Normal C_{Cr} is approximately 95 ± 20 mL/min in average-size adult women and 125 ± 25 mL/min in average-size adult men. Patients are instructed to urinate into the toilet on arising, and to mark this time as the start of the collection period. Next they are to pass all of their urine into a container during the ensuing day and night. The following morning, the patients are to urinate into the container one last time, and to note this time as the end of the collection period. By dividing the amount of creatinine in the collected urine by the number of minutes in the collection period (start time to finish time), the laboratory can calculate the per minute rate of creatinine excretion. A sample of blood must be drawn at some point during the urine collection period in which the serum creatinine level is measured. To calculate creatinine clearance, one simply divides the per minute creatinine excretion rate by the serum value. This gives the volume per minute of serum that had to have been “cleared” of creatinine by the kidneys. For example, if the per minute creatinine excretion rate is 1.0 mg/min, and the serum creatinine level is 1 mg/dL, or 0.01 mg/mL, then $1.0/0.01 = 100$ mL/min of serum were on average being cleared of creatinine by the kidneys during the collection period. Despite the technical challenge of collecting urine properly, timed urine collections are a very useful means of estimating kidney function in cachectic patients, including those with cirrhosis and ascites, as well as markedly obese patients. The completeness of the urine collection for creatinine can be estimated by comparing the amount of creatinine recovered per day based on the expected daily creatinine excretion rate for a given patient based on sex and body weight. Thus, one expects daily creatinine excretion to be about 15–20 mg/kg lean body weight in women and 20–25 mg/kg lean body weight in men. A more exact estimate of daily creatinine excretion rate can be obtained from the use of an equation incorporating body weight, gender, age, and race, such as that developed by Ix

(2011), and which is detailed as a nomogram in Appendix A. A creatinine excretion rate that is significantly less than expected usually indicates an incomplete urine collection.

Because creatinine is cleared by the renal tubules in addition to being filtered at the glomerulus, the creatinine clearance is greater than GFR. When $GFR/1.73\text{ m}^2$ is very low (e.g., less than 10–15 mL/min), the proportion of creatinine excretion due to tubular secretion is high. To get a more reliable estimate of GFR when GFR is low, one can measure the amounts of both creatinine and urea in the timed urine sample, and measure the serum urea level as well as the creatinine level during the collection period. The per minute clearance of urea is calculated in the same way as for creatinine. Urea is filtered at the glomerulus, but then some urea is reabsorbed by the renal tubules, so with urea, the situation is opposite to that with creatinine; due to tubular reabsorption, the urea clearance will be less than the GFR, whereas the creatinine clearance will be greater than the GFR. Averaging the urea and creatinine clearances has been shown to give a good estimate of GFR in patients with GFR less than 10–15 mL/min.

4. **Estimated creatinine clearance.** To avoid the inaccuracies and inconvenience of timed urine collections, creatinine clearance (C_{Cr}) can be estimated by using equations that estimate the per minute creatinine excretion rate based on age, body size, gender, and in some equations, race. One equation that has been used for this is the **Cockcroft–Gault equation**:

$$\text{Estimated } C_{Cr} = \frac{(140 - \text{Age}) \times (0.85 \text{ if female}) \times (W \text{ in kg})}{72 \times S_{Cr} \text{ in mg/dL}}$$

or

$$\text{Estimated } C_{Cr} = \frac{(140 - \text{Age}) \times (0.85 \text{ if female}) \times (W \text{ in kg})}{0.814 \times S_{Cr} \text{ in mmol/L}}$$

where W is body weight. This equation provides a quick and reasonably accurate estimate of renal function at the bedside. The more recently developed **Ix equation** (Ix, 2011), described in Appendix A, also can be used. The **Ix equation** was developed and validated in a much larger sample of individuals, including blacks, and was based on modern, IDMS-calibrated laboratory measures of creatinine. Neither equation is very accurate in markedly obese or cachectic patients. Some have suggested that the accuracy of the Cockcroft–Gault equation can be increased by using **actual body weight** for cachectic patients, **ideal body weight** for normal weight patients, and **adjusted body weight** for markedly obese patients (Brown, 2013). See Appendix B for more details.

5. **Estimated GFR**
 - a. **Modification of Diet in Renal Disease (MDRD) equation.** This equation was derived from the MDRD trial and reports eGFR normalized per 1.73 m^2 of body surface area. For laboratories using the new IDMS-standardized serum creatinine values, the version of the MDRD equation that should be used is what follows:

$$\text{eGFR}/1.73 \text{ m}^2 = 175 \times [\text{S}_{\text{Cr}}] - 1.154 \times [\text{Age}] - 0.203 \\ \times [0.742 \text{ if patient is female}] \times [1.210 \text{ if patient is black}].$$

The “175” term in this equation replaces the “186” term in the original published equation to account for the slightly lower values of IDMS-standardized creatinine assays compared to assays used in the MDRD study. When serum creatinine is measured in SI units (mcmol/L), one needs to divide the serum creatinine value by 88.5 to convert to mg/dL prior to inserting into the equation.

The MDRD GFR equation differs from the Cockcroft–Gault or Ix estimates of the creatinine clearance in several ways. First, it was developed from data that measured GFR by iothalamate, a substance which is not secreted by the renal tubules, and so it predicts GFR rather than creatinine clearance. All else being equal, the MDRD equation will give a lower value for renal function (GFR) than creatinine clearance, which includes the tubular secretion component of renal function. Secondly, the MDRD equation is normalized to body size and is expressed as eGFR/1.73 m² of body surface area. Creatinine clearance, whether obtained from a timed urine sample or from the Ix or Cockcroft–Gault equation, is raw renal creatinine clearance that has not been adjusted for body size.

- b. **The CKD-EPI GFR equation.** This is similar to the MDRD equation, but this newer equation was validated in a larger group of subjects, particularly those with only mild degrees of renal impairment. The CKD-EPI equation is listed in Appendix A. The differences between the two equations are usually not of clinical importance, as they occur primarily in patients with GFR levels greater than 60, where the impact of knowing the precise level of renal function is not particularly large.
 - c. **Cystatin C equations.** An alternative method of estimating GFR is based on equations that use the **serum cystatin C** level. Cystatin C is a 13-kDa protein produced by all cells that is filtered by the glomerulus and not reabsorbed. The production rate of cystatin C is not related to muscle mass or dietary meat intake, and cystatin C–based estimates of GFR correlate better with CKD-related outcomes than creatinine-based equations in some studies. Some of the newest efforts to predict GFR combine both serum creatinine and cystatin C levels (Levey, 2014). Laboratory methods of measuring cystatin C are not commonly standardized (this is in progress, similar to IDMS standardization of creatinine), and for the moment, cystatin C equations are not in wide use.
6. **Problems with estimated clearances in acute kidney injury.** The estimating equations based on either creatinine or cystatin are based on steady-state assumptions. If one were to surgically remove both kidneys, the serum creatinine or cystatin C levels would begin to rise, but this would take place over a number of days as opposed to immediately. For this reason, none of the renal function estimating equations described above are useful in situations where the level of kidney function is rapidly changing. The timed urine collection method can be used to measure creatinine clearance, but then serum creatinine levels need to be measured at both the beginning and end of the collection period, and the per minute excretion rate should be divided by the time-averaged serum

value in the calculations.

- C. **Ultrasound and serum electrolytes.** In patients found to have CKD, one should image the kidneys, commonly by ultrasound, to look for structural abnormalities and possible obstruction and measure serum electrolytes (Na, K, Cl, HCO₃) to screen for metabolic acidosis and electrolyte disorders, the presence of which may give clues to an underlying renal disease.
- D. **Looking for an etiologic diagnosis.** Identifying the underlying cause of CKD is important. The CKD may be reversible, for example in a patient with bilateral renovascular disease or chronic bladder neck obstruction from prostatic hypertrophy. The cause of CKD may provide insights into the tempo of disease progression. Since some etiologies of kidney disease are very likely to recur in a future kidney allograft, identifying the underlying cause of CKD at the outset may help in later management decisions.
- E. **Staging.** The National Kidney Foundation's (NKF) Kidney Disease Outcome Quality Initiative's (KDOQI) staging of CKD has been widely adopted. It stages CKD from stage 1 (mildest) to stage 5 (most severe) based on the level of eGFR normalized to body surface area. The two mildest stages—stages 1 and 2, in which the eGFR/1.73 m² is still above 60 mL/min—require evidence for kidney damage apart from reduced GFR. Kidney damage can be manifest as pathologic changes on kidney biopsy; abnormalities in the composition of the blood or urine (proteinuria or changes in the urine sediment examination), or abnormalities in imaging tests. The more severe stages of CKD—stages 3, 4, and 5—are present by definition when the GFR is below 60, 30, and 15, respectively. Some elderly patients with eGFR/1.73 m² in the range of 45–60 mL/min may not have obvious kidney damage, nor an increased risk of an accelerated decline in renal function or mortality. A subsequent staging system developed by KDIGO (Kidney Disease: Improving Global Outcomes) partially takes this into account by subdividing stage 3 CKD into two levels: 3a, with eGFR/1.73 m² in the range of 45–59 mL/min; and 3b, with GFR levels between 30 and 44 mL/min. Also, the newer staging system adds in the degree of proteinuria as measured by the UACR. One newer staging system is shown in Table 1.2, where a low risk of CKD progression and complications is indicated by “green,” and progressively increased risk is indicated by “yellow,” “orange,” and “red.”

II. SLOWING PROGRESSION OF CKD AND OF CARDIOVASCULAR DISEASE. In CKD patients, risk factors for progression of renal disease are very similar to those associated with increased cardiovascular risk. One purpose of identifying CKD patients early on is to attempt to correct and/or mitigate such risk factors, in the hopes of both maintaining GFR and minimizing cardiovascular risk. The main risk factors include smoking, high blood pressure, hyperglycemia in diabetic patients (and perhaps in nondiabetic persons as well), elevated blood lipid levels, anemia, and elevated serum phosphorus levels. Urinary protein excretion and even microalbuminuria markedly increase both the risk of progression and cardiovascular complications. Levels of inflammatory mediators, notably C-reactive protein (CRP), are increased in CKD and are associated with increased atherosclerotic risk.

eGFR category	eGFR/1.73 m ²	Normal to mildly increased	Moderately increased	Severely increased
		<3 mg/mmol	3–30 mg/mmol	>30 mg/mmol
		<30 mg/g	30–300 mg/g	>300 mg/g
1*	≥90	Green	Yellow	Orange
2*	60–89	Green	Yellow	Orange
3a	45–49	Yellow	Orange	Red
3b	30–44	Orange	Red	Red
4	15–29	Red	Red	Red
5	<15 on dialysis	Red	Red	Red

Colors denote the following: green = no risk if no other markers for kidney disease, no CKD; yellow = moderately increased risk; orange = high risk; red = very high risk.

*Not CKD unless hematuria or structural or pathological changes present. Risk of progression may be moderately high with certain causes of kidney disease.

Modified from Kidney Disease: Improving Global Outcomes (KDIGO) CKD Work Group. KDIGO 2012 Clinical Practice Guideline for the Evaluation and Management of Chronic Kidney Disease. *Kidney Int Suppl.* 2013;3:1–150.

- A. **Cessation of smoking.** Smoking is a traditional cardiovascular risk factor, and cessation of smoking is important in terms of limiting cardiovascular risk. Evidence suggests that smoking accelerates the rate of progression of renal disease, emphasizing the importance of stopping smoking by CKD patients.
- B. **Control of blood pressure and proteinuria.** The blood pressure target in CKD patients is evolving. The target blood pressure recommended by KDIGO and KDOQI is <130/80 mm Hg for all patients with kidney disease, those with and those without diabetes, regardless of degree of proteinuria. However, the Eighth Joint National Committee (JNC 8) guidelines published in 2013 recommend a less aggressive blood pressure target of <140/90 mm Hg in patients under age 60 with diabetes and kidney disease. Whether or not hypertension is present, use of an angiotensin-converting enzyme inhibitor/angiotensin receptor blocker (ACE-I/ARB) is recommended to slow the rate of progression in patients with diabetic kidney disease as well as in nondiabetic CKD patients with proteinuria (spot urine protein-to-creatinine ratio of ≥200 mg/g). Thiazide diuretics are the diuretic of choice for mild CKD, when S_{Cr} is <1.8 mg/dL (<160 μmol/L). When S_{Cr} is >1.8 mg/dL (>160 μmol/L), a loop diuretic (twice-a-day dosing regimen) is recommended, due to presumed reduced efficacy of thiazides under those circumstances; however, lack of efficacy of thiazides in patients with reduced GFR has been challenged. Chlorthalidone, a longer-acting thiazide diuretic, is effective in CKD in causing volume reduction (Agarwal, 2014), to the point that volume depletion–related side effects were observed.

Doses of ACE-Is/ARBs can be titrated up to minimize proteinuria, but blood pressure, potassium, and creatinine should be monitored after initiation of therapy and after each dose change. Sodium restriction and use of diuretics increase the antiproteinuric effects of ACE-I/ARB therapy. ACE-Is or ARBs are contraindicated in patients who are pregnant, particularly beyond the first trimester, and in patients with a history of

angioedema. For patients with an eGFR/1.73 m² of >15 mL/min, one rarely needs to adjust the dose of antihypertensive drugs downward due to impaired renal excretion, although the plasma half-life of some classes of antihypertensives will be increased (see Chapter 33).

- C. **Beta-blockers and aspirin: Cardioprotective effects.** Beta-blockers provide cardioprotection in CKD patients, although they are no longer recommended by JNC 8 (Eight Joint National Committee) as a first-line drug in treating hypertension. Aspirin and beta-blocker cardioprotection after myocardial infarction is similar in CKD patients and in patients with normal renal function. Aspirin has been associated with GI bleeding in end-stage kidney disease (ESKD) patients. Whether an increased risk is present in stages 1–4 CKD patients is not well known.
- D. **Strict glycemic control in diabetic patients with CKD.** Studies in patients with either type 1 or type 2 diabetes have demonstrated that tight glycemic control slows the development of microvascular and macrovascular disease. Tight glycemic control also slows the rate of progression of renal disease in diabetic patients with CKD. The goal of glycemic control should be a HbA1C of <7.0%, although the latest ADA guidelines have emphasized individualization of the HbA1C threshold in patients with type 2 diabetes, and KDIGO guidelines have suggested that this target be relaxed in patients at risk of hypoglycemia or with substantial comorbidities.
- E. **Lipid-lowering therapy.** Elevated levels of low-density lipoprotein (LDL) cholesterol and other lipid marker molecules are a traditional risk factor for cardiovascular disease, and the cardioprotective effects of statins in non-CKD patients, even when cholesterol levels are in the normal range, have been described in several studies. Data in animals suggest that high lipid levels and cholesterol loading may augment glomerular injury. Thus, treatment of CKD patients with statins to reduce lipids may both prevent progression and lower cardiovascular risk. The latest American College of Cardiology (ACC) and American Heart Association (AHA) lipid guidelines (Goff, 2014; Stone, 2013), which are targeted toward the general population and not toward CKD, identify four groups of patients for primary and secondary prevention using statins.
1. Individuals with clinical atherosclerotic cardiovascular disease
 2. Individuals with LDL cholesterol levels of ≥ 190 mg/dL (4.9 mmol/L)
 3. Diabetic patients without cardiovascular disease aged 40–75 years old with LDL cholesterol levels between 70 and 189 mg/dL (1.8 and 4.9 mmol/L)
 4. Patients without evidence of cardiovascular disease, and LDL cholesterol level 70–189 mg/dL (1.8–4.9 mmol/L), and a 10-year risk of atherosclerotic cardiovascular disease $\geq 7.5\%$.

CKD patients theoretically could be treated according to the same scheme, although using the AHA risk calculator (see the spreadsheet AHA risk calculator hyperlink attached to the reference listing for Goff [2014]), almost all patients greater than 63 years of age, even with the calculator's "optimal levels" of systolic blood pressure, LDL and HDL cholesterol, and without diabetes, will have a 10-year cardiovascular risk $>7.5\%$, even in the absence of CKD. Thus, these guidelines have been questioned regarding their rather intensive recommendations for use of statin therapy.

The 2013 KDIGO lipid guidelines recommend that all CKD patients (eGFR/1.73 m² <

60) not on dialysis and ≥ 50 years of age be treated with either a statin or a statin/ezetimibe combination. Patients ≥ 50 years of age who have CKD by virtue of some evidence of renal damage but with $eGFR/1.73\text{ m}^2 \geq 60$, namely stage 1 or 2 CKD, should be offered statin treatment only, as evidence for the benefits of a statin/ezetimibe combination in this group is not strong. Finally, younger CKD (age 18–49) not on dialysis should be treated with statins if they have known coronary disease, diabetes mellitus, prior ischemic stroke, or a 10-year CV risk greater than 10%. The 2013 KDIGO lipid guidelines recommend that statins or the statin/ezetimibe combination should not be initiated routinely in dialysis patients, but if the patients are already on these drugs when dialysis is initiated, then these drugs should be continued.

In nondialysis CKD patients, the benefits of these “lipid-lowering” drugs seem to be present regardless of the level of LDL cholesterol, and the current trend is to use overall cardiovascular risk and presence of comorbidity rather than LDL cholesterol levels as an indication for treatment. For a more complete discussion of treatment of dyslipidemias in stage 5 CKD patients receiving dialysis, see Chapter 38.

1. **Statins: Cardioprotective effects.** The cardioprotective effects of statins, well documented in nonuremic patients, are controversial in dialysis patients, but effectiveness appears to be present in nondialysis CKD, and statin use has been shown to retard progression of CKD in some studies (Deedwania, 2014).
 - a. **Dose adjustment for renal insufficiency.** Statins as a class have been associated with rhabdomyolysis, and dose reduction in severe renal impairment is recommended for some statins (e.g., rosuvastatin) or when statins are used in combination with fibrates (Chapter 38).
 2. **Ezetimibe.** Ezetimibe is an inhibitor of cholesterol absorption, and it decreases plasma levels of LDL cholesterol, triglycerides, and apolipoprotein B, and increases plasma levels of HDL cholesterol. As with statins, ezetimibe exerts significant antiatherogenic, anti-inflammatory, and antioxidant actions (Katsiki, 2013). The SHARP trial, where both nondialysis and dialysis patients were given a combination of simvastatin and ezetimibe (Sharp Collaborative Group, 2010), forms the basis of the recommendation to use ezetimibe in nondialysis CKD patients. However, it is not clear to what extent the benefits found were due to the statin (simvastatin) used, and to what extent, if any, the addition of ezetimibe contributed to the treatment benefit that was found.
- F. **Protein restriction.** Dietary protein restriction as a treatment to slow CKD progression remains controversial. Evidence from animal studies demonstrates that diets high in protein lead to histologic abnormalities in the kidney and to proteinuria. Furthermore, restricting protein intake slows progression. However, randomized clinical trials suggest that the effects of protein restriction are likely to be small and difficult to achieve. Nonetheless, evidence does support some benefit and indeed meta-analyses suggest that protein restriction is beneficial in reducing CKD progression. One reasonable approach is to restrict protein intake to about 0.8 g/kg per day in all patients with CKD. Recommendations differ from various guideline groups regarding the benefits of any further restriction of protein intake. The 2000 KDOQI guidelines suggested a restriction to 0.6 g/kg per day in those with a $eGFR/1.73\text{ m}^2 < 25\text{ mL/min}$ might be beneficial, but in general,

Canadian, many European, and the most recent KDIGO guidelines do not recommend protein restriction below 0.8 g/kg per day at any level of renal function. One needs to apply judgment when restricting protein intake, especially in malnourished CKD patients. Patients who are malnourished at the start of dialysis have a poorer survival than their well-nourished counterparts, and restricting food choices always carries the risk of a worsening nutritional status. Close follow-up for any evidence of malnutrition, either by clinical parameters or by serum albumin, is essential. A dietitian should be monitoring such patients carefully. The recommended caloric intake is 30–35 kcal/kg per day. In stage 4 and 5 patients, evidence of failing nutritional status is one key determinant in the decision to begin dialysis therapy.

III. MANAGEMENT OF COMPLICATIONS OF CKD.

- A. **Correction of anemia.** Anemia is common in CKD patients. As kidney disease advances, the incidence and prevalence of anemia increase. Anemia of CKD is multifactorial in etiology. The most common causes are erythropoietin deficiency, iron deficiency, and inflammation. Observational studies have suggested an increased risk of cardiovascular and renal complications, lower quality of life, and higher mortality with a lower Hb level. However, large randomized clinical trials have demonstrated that correction of anemia to a Hb level of 13 g/dL (130 g/L) and above with an erythropoiesis-stimulating agent (ESA) is associated with either no benefit or an increased risk of cardiovascular complications, stroke, and/or death. Also, correction of anemia is associated with either no effect on kidney progression or an increased rate of ESKD. Recent studies have found an association between exposure to high doses of ESA and heightened risk of adverse events. It is not clear to what extent this is causal or a reflection of the relatively high Hb targets used and the known association of ESA resistance with poor outcome. Contemporary approaches to anemia management have now emphasize only partial correction of anemia, using the lowest possible dose of ESA, together with treatment of iron deficiency and inflammation.
1. **Initiation of ESA therapy and Hb thresholds.** Diagnosis and management of anemia in nondialysis CKD patients is similar to that in ESKD and is discussed in detail in Chapter 34. The KDIGO guidelines recommend that erythropoietin therapy should not be started until the hemoglobin falls below 10 g/dL (100 g/L). KDIGO guidelines recommend to maintain the hemoglobin level between 9 and 11.5 g/dL (90 and 115 g/L), although the US FDA now recommends that ESA dosing should be reduced or interrupted if the Hb level exceeds 11 g/dL (110 g/L). Treatment of anemia in CKD with ESA therapy should be individualized, and one of the main goals should be to reduce the need for blood transfusion. The KDIGO guidelines counsel caution when treating CKD patients with a history of prior stroke or cancer. Thus, the effective Hb goal, in the United States at least, is 9–11 g/dL (90–110 g/L). Controversy exists as to whether a Hb level of 9 g/dL (90 g/L) may be too low in CKD patients, since this might increase use of blood transfusion and expose patients eligible for kidney transplantation to the allosensitizing effects of transfused blood.
 2. **Types of ESA therapy.** There are short-acting and long-acting ESAs. Epoetin alfa, approved in 1989 and available worldwide, is a short-acting ESA with a half-life

when given intravenously of about 8 hours and 16–24 hours when given subcutaneously. Several different short-acting ESAs and their biosimilars are available in non-US markets. A typical dose in a CKD patient might be 4,000–6,000 units subcut. once a week. The most widely used long-acting ESA is darbepoetin alfa with a half-life of about 25–50 hours when given IV or subcut., respectively. The optimal administration dosing schedule for darbepoetin alfa is once weekly (a typical dose might be 20–30 mcg) or every 2 weeks (40–60 mcg) in a stable CKD patient. The dose does not differ if given by intravenous route or subcutaneous route. Outside of the United States, another long-acting ESA has been approved and marketed for use; this is Continuous Erythropoietin Receptor Activator (CERA), which is a compound where a water-soluble polyethylene glycol (PEG) moiety has been added to the epoetin beta molecule. The half-life is approximately 136 hours. CERA is recommended to be administered every 2 weeks for correction of anemia and then once a month during the maintenance phase (typical dose 150 mcg/month).

3. **Frequency of administration and route of administration of ESAs.** The frequency of ESA administration is usually influenced by patient convenience and efficacy considerations. In nondialysis CKD patients, longer-acting ESAs are preferred because their use is associated with fewer injections and/or visits to a doctor's office for administration in the event that a patient cannot self-administer, but the shorter-acting ESAs can be dosed once a week, or even once every 2 weeks, with considerable effect.
 4. **Resistant anemia.** Patients may be classified as having ESA hyporesponsiveness if they have no increase in Hb level from baseline after the first month of ESA treatment on appropriate weight-based dosing. The KDIGO Work Group recommends that in these patients, escalation of ESA dose should not go beyond double the initial weight-based dose; further, KDIGO recommends avoiding maximal doses no greater than four times initial weight-based appropriate doses. In patients with initial or acquired ESA hyporesponsiveness, evaluation for specific causes of poor ESA response should be undertaken.
- B. **Correction of iron deficiency.** Iron deficiency is present in over 40% of patients with CKD not on dialysis and is the most common cause of apparent ESA resistance. The causes of iron deficiency are multifactorial but include reduced absorption of iron; blood loss from either frequent blood draws or occult GI blood loss, and reduced nutritional intake.
1. **Assessment of iron deficiency.** Iron status (iron stores and bioavailable iron levels) should be evaluated regularly in patients with CKD. Ferritin is an iron storage protein and its serum levels reflect iron storage. Serum ferritin is also an acute phase reactant, however, and patients with CKD often exhibit chronic inflammation; therefore, the ferritin level should be interpreted cautiously in inflamed patients. Serum ferritin values are of greatest predictive value for iron deficiency when low (<100 ng/mL), but are of limited value when elevated. The transferrin saturation (TSAT; serum iron \times 100 / total iron binding capacity) is the most common method of measuring iron bioavailability. A TSAT <20% is indicative of low iron availability in CKD. Iron deficiency can lead to decreased effectiveness of ESA therapy, and iron therapy

without ESA therapy is usually unsuccessful in patients with CKD. Therefore, before initiating ESA therapy, iron status must be addressed.

2. **Treatment of iron deficiency anemia.** Options for therapy depend on the stage of CKD and include oral and intravenous therapies. Oral iron therapy is the preferred method of treating nondialysis CKD patients and is recommended by KDIGO as an initial approach to treating iron deficiency. Strategies to improve oral iron absorption include only taking pills on an empty stomach, avoiding enteric-coated formulations, and avoiding ingestion of iron with phosphate binders. Intravenous iron may be needed in some patients who either do not respond to oral iron or have large ongoing losses of iron (e.g., chronic bleeding from the gastrointestinal tract). The use of low-molecular-weight iron therapy is recommended—low-molecular-weight dextrans, ferrous gluconate, iron sucrose, or ferumoxytol. The use of high-molecular-weight iron dextran has been associated with an increased risk of severe anaphylaxis.

Dosing strategies for oral iron aim at providing approximately 200 mg of elemental iron daily, which is equivalent to ferrous sulfate 325 mg three times daily; each pill providing 65 mg of elemental iron. If iron repletion goals are not met after a 1–3 month trial, it is appropriate to consider intravenous iron supplementation. Intravenous iron can be administered as a single large dose or as repeated smaller doses, depending on the preparation used. The initial course of intravenous iron treatment is to supply approximately 1,000 mg of iron. This may be repeated if the initial course of treatment fails to increase Hb level and/or decrease ESA dose. Iron status should be monitored every 3 months with TSAT and ferritin while a patient is receiving ESA therapy and more frequently when initiating or increasing ESA dose, in the setting of ongoing blood loss, or in circumstances where iron stores are likely to become depleted.

- C. **Chronic Kidney Disease-Mineral and Bone Disorder (CKD-MBD).** The pathogenesis of CKD-MBD is depicted in Figure 1.1. The management of serum phosphorus, vitamin D, and parathyroid hormone (PTH) levels in dialysis patients is fully discussed in Chapter 36 and only issues pertinent to CKD will be discussed here.

1. **Hyperphosphatemia.** A high serum phosphorus level is a risk factor for mortality and adverse cardiovascular outcomes in both CKD and ESKD patients. Even in nonuremic patients, mild serum phosphorus elevation is associated with increased cardiovascular risk. Hyperphosphatemia is associated with increased risk of vascular calcification and left ventricular hypertrophy in ESKD. In a number of experimental renal failure models, hyperphosphatemia accelerates progression of renal failure. In such models, hyperphosphatemia stimulates parathyroid gland growth and PTH secretion.

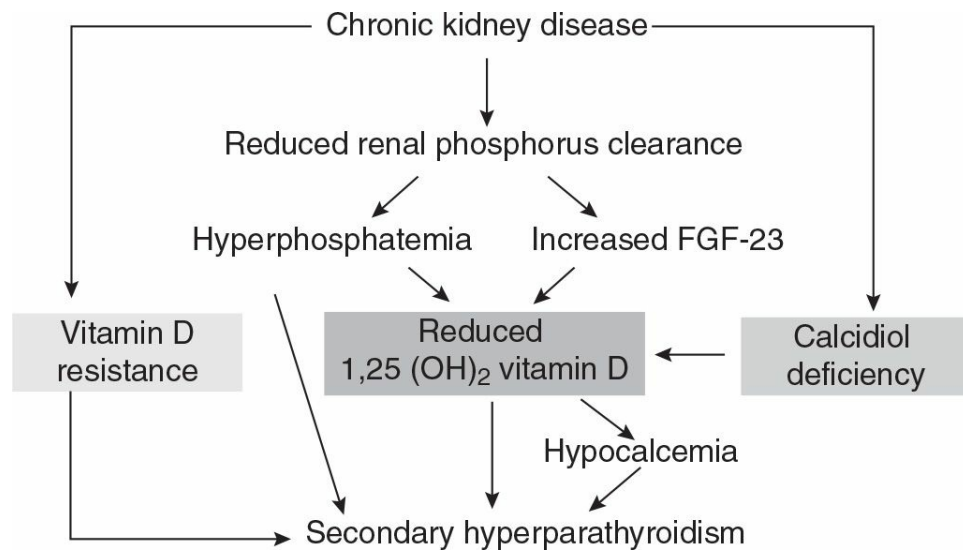

FIGURE 1.1 Pathogenesis of MBD. (Reprinted by permission from Macmillan Publishers Ltd: Nigwekar SU, Tamez H, Thadhani RI. Vitamin D and chronic kidney disease-mineral bone disease (CKD-MBD). *Bonekey Rep.* 2014;3:498. eCollection 2014.)

- a. **Dietary management.** Management includes a careful dietary review to look for abnormally high consumption of foods rich in phosphorus, including dairy products, certain colas, and processed meats. A careful review of the diet should be made with the goal of reducing consumption of foods containing phosphorus additives. Phosphorus intake should be restricted to 800–1,000 mg per day (26–32 mmol per day).
- b. **Target serum calcium and phosphorus levels.** Previous recommendations to maintain serum calcium at the high end of the normal range to ensure PTH suppression have been replaced by a strategy of keeping serum calcium toward the middle or low range of normal, to minimize the risk of vascular calcification. Similarly serum phosphorus levels should be maintained within the normal range.
- c. **Phosphorus binders.** Phosphorus binders may need to be used. The choices are described in Chapter 36. It is prudent to restrict total calcium intake in CKD patients to about 1,500 mg per day (37 mmol per day) (KDOQI guidelines are less restrictive and suggest a ceiling of 2,000 mg per day [50 mmol per day]), to minimize the risk of vascular calcification. This means that if calcium salts are used as phosphorus binders, they may need to be combined with sevelamer, lanthanum, or, possibly, magnesium or one of the newer iron-containing phosphorus binders described in Chapter 36. Aluminum-containing phosphorus binders generally should not be used. Use of sevelamer as a phosphorus binder has been shown to perhaps stabilize the rate of vascular calcification in CKD patients and to improve outcomes, although studies are not definitive in this area. It has been argued that if there is a beneficial effect, it may be due partially to the lipid-lowering effects of sevelamer, and sevelamer may have additional anti-inflammatory effects and may act to reduce FGF23 (fibroblast growth factor 23), a compound found in markedly increased concentration in the blood in CKD that also is associated with poor outcome. This remains an active area of ongoing

research.

2. **Serum parathyroid hormone levels.** Control of serum PTH levels is important to minimize the degree of parathyroid gland hypertrophy and the risk of developing large, nonsuppressible glands. Hyperparathyroidism is associated with bone disease, and PTH may also act as a uremic toxin with adverse effects on many different organ systems. The control of PTH secretion is detailed in Chapter 36.
 - a. **Frequency of measurement.** The 2009 KDIGO clinical practice guidelines for bone metabolism and disease in CKD recommend measuring PTH levels, as well as serum calcium and phosphorus, in all patients with a eGFR/1.73 m² <60 mL/min, though this may not be necessary in elderly patients with eGFR/1.73 m² in the 40–65 mL/min range and few risk factors for progression of CKD. The frequency of these measurements should be every 12 months for eGFR/1.73 m² values between 30 and 45–60 mL/min, and every 3 months when eGFR/1.73 m² is between 15 and 30 mL/min.
 - b. **Target range of PTH.** The intact PTH assay has been available since 1990 and identifies both 1–84 and 7–84 PTH, and most bone biopsy studies on which target levels are based have employed this assay. Bio-intact PTH, also known as biPTH or whole PTH, is a newer assay that responds only to the complete 1–84 PTH molecule, resulting in PTH values that are about half as high as those measured by the previous “intact” PTH assay. Either assay can be employed for diagnosis and treatment of hyperparathyroidism in CKD, but the target PTH range will depend on the specific assay employed. As CKD progresses, the bone becomes resistant to the actions of PTH, and so the target PTH range increases. The initial KDOQI recommendations proposed various targets for PTH at different levels of renal impairment, but given the wide variation among assays and uncertainty of benefit, the 2009 KDIGO guidelines simply recommend that for nondialysis CKD, assay-specific elevated levels of PTH be investigated, and treated with vitamin D if found to be persistently high and/or increasing. In dialysis patients, a target PTH range of 2–9 times normal is proposed as being desirable. In nondialysis CKD patients, the recommended first-line treatment of elevated PTH levels is recommended to be vitamin D therapy.
3. **Serum alkaline phosphatase.** Alkaline phosphatase is present in bone and is an indicator of bone turnover rate. When high, particularly in combination with elevated serum PTH, serum alkaline phosphatase can be a reasonably good indicator of a hyperactive parathyroid gland that needs to be suppressed. The current KDIGO CKD-MBD guidelines recommend at least yearly monitoring of serum alkaline phosphatase levels for stage 4 CKD and higher.
4. **Vitamin D.** In CKD patients, 25-D levels are quite low, probably because of lack of sunlight exposure and low ingestion of vitamin D-containing foods. As CKD progresses, the rate of conversion of 25-D to 1,25-D by the 1- α -hydroxylase enzyme diminishes, and even with adequate 25-D levels, serum 1,25-D levels may be reduced and PTH suppression may be inadequate. Vitamin D affects multiple organ systems; most of these effects are beneficial, although excess vitamin D has been associated

with vascular calcification and even accelerated renal failure. The 1- α -hydroxylase enzyme exists in various tissues, suggesting that it may be important to ensure proper levels of both 25-D and 1,25-D in the circulation for optimum health. Recently active vitamin D sterol administration has been linked to improved survival and improved cardiovascular outcomes in ESKD patients. The mechanism of this survival benefit is not clear, and these are observational studies that need to be confirmed. In addition, in small randomized trials, vitamin D treatment has been shown to reduce proteinuria and slow progression of CKD (Palmer and Strippoli, 2013), and vitamin D also may improve ESA sensitivity and reduce anemia by reducing inflammation.

- a. **Target serum levels of 25-D in CKD.** Serum levels of 25-D should be at least 30 ng/mL (75 nmol/L). Low serum levels of 25-D have been linked to severe muscle weakness in elderly nonuremic patients. Because CKD patients typically have very low levels of 25-D in the serum, for primary prevention, CKD patients should be supplemented with at least 1,000–2,000 IU of cholecalciferol per day, and higher doses may be needed. Cholecalciferol is available in the United States only as an over-the-counter vitamin supplement. This level of cholecalciferol supplementation does not affect GI absorption of calcium or phosphorus. To treat a low serum 25-D level, the 2003 KDOQI bone disease guidelines recommended using ergocalciferol, which is slightly less effective than cholecalciferol and is available only in relatively large dosage forms designed to be prescribed weekly or monthly. Ergocalciferol does have the advantage in the United States of being available as a formulary drug.
 - b. **When to use active vitamin D preparations.** In the more severe stages of CKD, conversion of 25-D to 1,25-D in the kidney becomes suboptimal, and even with adequate stores of 25-D, the serum levels of 1,25-D may remain low. In such situations, PTH often is not adequately suppressed. In stages 3 and 4 CKD patients in whom serum PTH remains above the target range despite adequate serum levels of 25-D, the use of an active vitamin D preparation is indicated. Choices and doses of active vitamin D preparations (e.g., calcitriol, paricalcitol, and doxercalciferol) are outlined in Chapter 36. As in ESKD patients, when active vitamin D sterols are being given, the dose should be held or reduced in the presence of hypercalcemia or hyperphosphatemia.
5. **Cinacalcet.** Cinacalcet is a calcimimetic drug that increases the sensitivity of calcium receptors on the parathyroid gland to calcium, resulting in a decrease in PTH secretion. One main advantage of cinacalcet is its use in patients with hyperparathyroidism and high serum calcium and/or phosphorus levels, where use of active vitamin D sterols to suppress PTH would be contraindicated (active vitamin D sterols increase GI absorption of phosphorus and may worsen hyperphosphatemia). Cinacalcet has been shown to lower PTH levels in stages 3 and 4 CKD patients. The relative roles of cinacalcet versus active vitamin D sterols for PTH suppression in predialysis patients are not yet well defined. In the United States, product labeling of cinacalcet states that the drug is not indicated for use in nondialysis patients and the 2009 KDIGO CKD-MBD guidelines do not recommend its use in the nondialysis CKD population.

D. **Electrolyte and acid–base complications.** A variety of electrolyte abnormalities may become apparent as kidney function declines. The most prominent is hyperkalemia. Acidosis can also develop although it is generally mild and usually with a normal anion gap until kidney function is severely impaired. Treatment of acute hyperkalemia is discussed elsewhere. In the chronic setting, hyperkalemia usually is the result of relatively high dietary potassium intake, and especially, binge intake of high potassium foods such as fruits. Hyperkalemia is also more commonly found in patients taking ACE inhibitors or angiotensin receptor blockers or mineralocorticoid receptor antagonists such as aldosterone. It also is more common in patients taking nonsteroidal anti-inflammatory drugs as well as trimethoprim. The recent development of novel gastrointestinal sorbents to prevent absorption of ingested potassium may allow more widespread use of renin–angiotensin aldosterone system (RAAS) antagonists.

Chronic metabolic acidosis results in increased resorption of bone, and also has been associated with an increased rate of progression of CKD. The use of sodium bicarbonate is recommended to maintain the serum bicarbonate level at ≥ 22 mmol/L. The usual amount of sodium bicarbonate to give is 0.5–1.0 mmol/kg per day. Alkali therapy has been shown to slow the rate of progression of CKD in several small randomized trials.

IV. PREPARING A PATIENT FOR DIALYSIS. Tasks here include preparation for dialysis or preemptive kidney transplantation; placement of vascular or peritoneal access; choosing the most appropriate mode and location of dialysis (i.e., peritoneal dialysis, outpatient hemodialysis center, home hemodialysis); vaccinations; continued nutritional management, particularly in terms of phosphorus control; and prevention of fluid overload and hypertension. These are discussed in more detail in the next chapter.

References and Suggested Readings

- Agarwal R, et al. Chlorthalidone for poorly controlled hypertension in chronic kidney disease: an interventional pilot study. *Am J Nephrol*. 2014;39:171–182.
- American Diabetes Association. Executive summary: standards of medical care in diabetes—2012. *Diabetes Care*. 2012;35(suppl 1):S4–S10.
- Brown DL, Masselink AJ, Lalla CD. Functional range of creatinine clearance for renal drug dosing: a practical solution to the controversy of which weight to use in the Cockcroft-Gault equation. *Ann Pharmacother*. 2013;47:1039–1044.
- Daugirdas JT, ed. *Handbook of Chronic Kidney Disease Management*. Wolters Kluwer; Philadelphia, 2011.
- Deedwania PC. Statins in chronic kidney disease: cardiovascular risk and kidney function. *Postgrad Med*. 2014;126:29–36.
- Eckardt KU, et al. Evolving importance of kidney disease: from subspecialty to global health burden. *Lancet*. 2013;382:158–169.
- Fink HA, et al. Screening for, monitoring, and treatment of chronic kidney disease stages 1 to 3: a systematic review for the U.S. Preventive Services Task Force and for an American College of

Physicians Clinical Practice Guideline. *Ann Intern Med.* 2012;156:570–581.

Goff DC Jr, et al. 2013 ACC/AHA Guideline on the Assessment of Cardiovascular Risk: *J Am Coll Cardiol.* 2014;63;2935–2959. Downloadable CV Risk calculator in Excel format: http://static.heart.org/ahamah/risk/Omnibus_Risk_Estimator.xls. Accessed April 28, 2014.

Ix JH, et al. Equations to estimate creatinine excretion rate: the CKD epidemiology collaboration. *Clin J Am Soc Nephrol.* 2011;6:184–191.

James PA, et al. 2014 evidence-based guideline for the management of high blood pressure in adults: report from the panel members appointed to the Eighth Joint National Committee (JNC 8). *JAMA* 2014;311:507–520.

Katsiki N, et al. Ezetimibe therapy for dyslipidemia: an update. *Curr Pharm Des.* 2013;19:3107–3114.

Kidney Disease: Improving Global Outcomes (KDIGO) Anemia Work Group. KDIGO Clinical Practice Guideline for Anemia in Chronic Kidney Disease. *Kidney Int Suppl.* 2012;2:279–335.

Kidney Disease: Improving Global Outcomes (KDIGO) CKD-MBD Work Group. KDIGO clinical practice guideline for the diagnosis, evaluation, prevention, and treatment of chronic kidney disease-mineral and bone disorder (CKD-MBD). *Kidney Int.* 2009;76(suppl 113):S1–S130.

Kidney Disease: Improving Global Outcomes Lipid Guideline Development Work Group Members. KDIGO Clinical Practice Guideline for Lipid Management in CKD: summary of recommendation statements and clinical approach to the patient. *Kidney Int Suppl.* 2013;3:259–305.

Levey AS, et al. The definition, classification, and prognosis of chronic kidney disease: a KDIGO Controversies Conference report. *Kidney Int.* 2011;80:7–28.

Levey AS, Coresh J. Chronic kidney disease. *Lancet.* 2012;379:165–180

Levey AS, Inker LA, Coresh J. GFR estimation: from physiology to public health. *Am J Kidney Dis.* 2014;63:820–834.

Macgregor MS, Methven S. Assessing kidney function. In: Daugirdas JT, ed. *Handbook of Chronic Kidney Disease Management.* Philadelphia, PA: Wolters Kluwer; 2011:1–18.

National Kidney Foundation (NKF). KDOQI clinical practice guidelines for bone metabolism and disease in chronic kidney disease. *Am J Kidney Dis.* 2003;42(4 suppl 3):S1–S201.

Palmer SC, Strippoli GF. Proteinuria: does vitamin D treatment improve outcomes in CKD? *Nat Rev Nephrol.* 2013;9:638–640.

Ptinopoulou AG, Pikilidou MI, Lasaridis AN. The effect of antihypertensive drugs on chronic kidney disease: a comprehensive review. *Hypertens Res.* 2013;36:91–101.

Sharp Collaborative Group. Study of Heart and Renal Protection (SHARP): randomized trial to assess the effects of lowering low-density lipoprotein cholesterol among 9,438 patients with chronic kidney disease. *Am Heart J.* 2010;160:785–794.

Stone NJ, et al. 2013 ACC/AHA guideline on the treatment of blood cholesterol to reduce atherosclerotic cardiovascular risk in adults: a report of the American College of Cardiology/American Heart Association Task Force on Practice Guidelines. *Circulation.* 2014;129(25 suppl 2):S1–S45.

2

Management of CKD Stages 4 and 5: Preparation for Transplantation, Dialysis, or Conservative Care

Ajay Singh and Jameela Kari

Once a patient has reached stage 4 chronic kidney disease (CKD), with size-adjusted estimated glomerular filtration rate (eGFR/1.73 m²) of <30 mL/min, he or she should be under a nephrologist's care. Ideally, the patient should also be a part of a multidisciplinary predialysis program that includes patient and family education, early choice of appropriate renal replacement modality, and, if dialysis is being considered, elective creation of dialysis access. The advantage of a programmatic approach to care is a planned outpatient initiation of dialysis in a patient who is both mentally and physically prepared. It is likely that this approach results in fewer hospital days in the first month after beginning dialysis and substantial cost savings.

I. CHOICE OF MODALITY

- A. **Patient education.** Of key importance is patient education about the various treatment options available in the event that renal replacement therapy will become necessary. Would the patient best benefit from some form of dialysis, from preemptive transplantation, or from continued conservative management? In some cases, due to extreme patient debility or other reasons, dialysis may not be an appropriate option, and conservative management may be the best choice. These discussions are best initiated once a patient is still in stage 4 CKD, and well before stage 5 has been reached.
- B. **Options for renal replacement therapy (Table 2.1)**
 1. **Preemptive transplantation.** Transplantation offers survival superior to the standard forms of dialysis being offered today. Transplantation may not be indicated, however, for a patient who has severe problems with compliance in terms of medications. Preemptive transplantation has a higher success rate in general than when transplantation is initiated after hemodialysis (Kallab, 2010), and for this reason, discussions about the feasibility of transplantation and transplantation workup should begin well in advance of any need for dialysis, usually when eGFR/1.73 m² is still well above 10 mL/min (Kupin, 2011).

TABLE

Treatment Options in Patients Who Need Renal Replacement Therapy

Modality	Description	Advantages	Disadvantages
Preemptive transplantation	Live or cadaver donor transplant before ever needing dialysis	Improved patient survival relative to conventional dialysis; lower long-term costs.	Logistics of finding a suitable donor; need for compliance with immunosuppressive drugs.
Home hemodialysis	3–6 times per week, either during the day or at night. Usually assisted by a relative or caregiver; uncommonly, by a paid health-care professional	When given more than 3 times per week, or when given as 8–10-hour treatments, 3–3.5 nights per week, evidence suggests better quality-of-life and better control of phosphate and blood pressure; may also reduce left ventricular hypertrophy	Home is changed into a hospital; partner burnout; with some home therapies, modification to home water systems is required; waste disposal; expense
Home PD	Automated cyclers, with most exchanges done during the night	Independence, relative simplicity	Need for delivery of large volumes of PD fluid; exposure to high amounts of glucose
In-center nocturnal hemodialysis	Three 7–9-hour nocturnal treatments per week (or uncommonly, every other night) given in-center (either staff assisted or self-care)	Marked increase in weekly dialysis time with better control of phosphate, blood pressure, and anemia. Home does not need to be converted into a clinic. Dialysis time spent sleeping	Leaving home unattended on dialysis nights; travel to unit; relatively inflexible schedule
In-center conventional hemodialysis	Either staff assisted (the norm) or self-care	Short amount of time spent on dialysis. Staff does all the work	Travel to unit; relatively inflexible schedule. May be inadequate amount of dialysis
Postponing dialysis	Very-low-protein diet plus ketoanalogues, careful fluid management	May work to postpone dialysis for about 1 year in elderly patients with few comorbidities (no heart failure, diabetes)	Expense of ketoanalogues
Palliative care	Conservative management without dialysis	Good for those patients for whom dialysis is not expected to prolong life to a significant extent or in whom overwhelming comorbidities are present	Potentially reduced life expectancy

Modified from Tattersall JE, Daugirdas JT. Preparing for dialysis. In: Daugirdas JT, ed. *Handbook of Chronic Kidney Disease Management*. Philadelphia, PA: Wolters Kluwer Health, Lippincott Williams & Wilkins, 2011:511–523.

2. **Dialysis: Home versus in-center therapy.** Among the end-stage renal disease (ESRD) therapies, the choices made will depend on what is available in the local community. One of the main decisions to be made is whether the patient will be coming in to a clinic for regular dialysis (hemodialysis in this case), or whether he or she would prefer the independence of dialyzing at home, using either a home hemodialysis system

or peritoneal dialysis (PD). Obviously transportation issues are very important here, as is the status of a patient's home, the amount of support available through interested family members who might assist as caregivers, and technical issues such as available water quality and electricity.

In observational studies, mortality rates are lower in home hemodialysis patients than in in-center hemodialysis patients, sometimes dramatically so, even after adjustments for common comorbidities and at similar total weekly dialysis times. Some of this home dialysis advantage may be due to unaccounted for patient selection bias, as patients undertaking the responsibility to dialyze at home usually have a strong positive attitude, good compliance, and strong caregiver and/or family support structure, factors which are associated in their own right with increased survival. Mortality rates for in-center hemodialysis are similar to those for home PD, so the selection of home versus in-center modality should be based primarily on patient preferences versus any anticipated survival benefit.

3. **“Short daily” hemodialysis.** Normally, whether done at home or in-center, hemodialysis therapy is offered 3 times per week, usually 3–5 hours per session. When the same amount of dialysis time is broken up into five or six sessions per week, some observational studies have shown better control of blood pressure, better nutrition (weight gain, increased appetite and albumin), and better control of anemia. In the only moderate-sized randomized trial that has been done, the FHN trial, where patients were randomized to get 6 treatments per week but in fact averaged only 5, those assigned to more frequent dialysis for 1 year were found to have reduction in left ventricular hypertrophy, improved physical functioning (those were the two primary outcomes of the FHN trial), a reduced severity of hypertension, and marginally improved control of serum phosphorus. There was no improvement in serum albumin, nutritional measurements, or control of anemia (FHN Trial Group, 2010). The details of various “short daily” hemodialysis regimens are discussed in Chapter 16. Usually frequent hemodialysis is done at home and is only rarely offered in-center or in self-care units. “Short daily” hemodialysis is gaining in popularity, especially with the availability of easy-to-use machines dedicated to delivering such therapy in the home setting.
4. **Long nocturnal hemodialysis.** With “short daily” hemodialysis, the number of hours spent per week on dialysis is usually similar to, or only slightly greater than, the weekly time spent on conventional 3 per week in-center dialysis. With nocturnal dialysis, substantially longer weekly dialysis times are the norm, because each session typically lasts for 7–9 hours. When nocturnal dialysis is given in-center, the usual frequency is 3 times per week, and the weekly dialysis time will be 24 hours per week compared to the usual 12 hours per week with conventional schedules. When applied at home, nocturnal dialysis can be given 3 times per week, every other night, or even 5 to 6 times per week, resulting in markedly more hours per week of treatment than conventional therapy. Long nocturnal dialysis is discussed in more detail in Chapter 16.
5. **Peritoneal dialysis.** Due to its simplicity, PD offers patients a home-based therapy with very little requirement for special water systems and simple equipment setup time. The

percentage of patients choosing PD over hemodialysis is about 12% in the United States and 20%–30% in Canada. There are two types of PD for a patient to consider: continuous ambulatory peritoneal dialysis (CAPD), where a patient performs manual exchanges 4 or 5 times per day, and automated peritoneal dialysis (APD), where a patient hooks up to a machine at night and exchanges are carried out automatically while the patient sleeps. The relative benefits of each type of PD are discussed more fully in the PD chapters of this handbook.

Patients for whom PD is often favored include:

1. Infants or very young children
2. Patients with severe cardiovascular disease
3. Patients with difficult vascular access (e.g., diabetic patients)
4. Patients who desire greater freedom to travel
5. Patients who wish to perform home dialysis but do not have a suitable partner to assist them

Contraindications include an unsuitable peritoneum due to the presence of adhesions, fibrosis, or malignancy. Also, a substantial number of patients experience an increase in their peritoneal membrane transport rate over time, resulting in inadequate ultrafiltration. Diabetic patients tend to have a higher mortality when placed on PD versus hemodialysis, although in recent years this trend appears to have attenuated. A major cause of abandonment of PD is the occurrence of frequent episodes of peritonitis. Patient burnout is also a factor.

PD is less expensive than hemodialysis, particularly in developing countries. Also, it allows patients independence and freedom to travel and does not constrain patients to a fixed in-center hemodialysis schedule, although a more flexible schedule is also possible with home hemodialysis. PD may not be the best option for patients who do not have a “do-it-yourself” mentality or who do not have the stability or social and family support at home to carry out a PD program. Some patients simply prefer a hemodialysis schedule of three or more well-defined periods per week during which they can get their dialysis “over with,” leaving them free of any other dialysis responsibility. Some patients also enjoy the socialization that occurs in many hemodialysis units, and enjoy the regular personal interaction with staff and other patients.

There have been a number of improvements in PD over the past several years, including better disconnect systems, resulting in decreased peritonitis rates. Also, with use of APD, there can be improved clearances. New PD solutions have become available, including glucose-based solutions with decreased amounts of glucose degradation products, as well as solutions using amino acids or icodextrin as the osmotic agent.

6. **Postponing dialysis.** In some patients, particularly the elderly, who do not have marked problems with fluid overload, the need for dialysis can be postponed by prescribing a very-low-protein diet supplemented with ketoacids (Brunori, 2007). In carefully selected elderly patients assigned to this strategy, the need for dialysis was postponed on average by 1 year.

7. **The option not to dialyze: Palliative care.** There are no absolute contraindications to dialysis therapy. In some states, legal precedent exists guaranteeing dialysis to anyone who desires it despite the severity of other medical problems. When a patient is unable to voice his or her own thoughts and when the family has divided opinions about the desirability of initiation of life support by dialysis, the hospital ethics committee may be of assistance.

The U.S. Renal Physicians Association has issued a clinical practice guideline for stopping or never beginning dialysis in certain patients (Renal Physicians Association, 2010), which consists of 10 recommendations for adult patients and 9 for pediatric patients. The guidelines emphasize shared decision making, informed consent or refusal, estimating prognosis, and a time-limited trial of dialysis where indicated. The adult recommendations are summarized in Table 2.2. Patients with advanced disease in an organ system other than the kidneys, or those with malignancy, have sometimes been excluded from chronic dialysis. For example, those with advanced liver disease might have ascites, encephalopathy, bleeding diathesis, and hypotension. These concomitant problems may make access difficult, and the dialysis treatments may create too much hypotension or fail to correct the accompanying fluid overload. In some such patients, dialysis may be futile. Futility is an ethical principle on which one can make a reasonable decision not to initiate dialysis. On the other hand, some such patients may achieve good quality-of-life and “remission” of failure of other affected organ systems with the fluid removal, electrolyte balance, and improved nutrition provided by multidisciplinary ESRD management.

- C. **Elderly patients and dialysis.** In the United States and elsewhere, the fastest growing age group presenting for dialysis is the “oldest old” (patients older than 80 years). Access placement in this group is not particularly difficult, and cuffed venous catheters have been used with success in difficult cases. Time constraints are not a problem, and these individuals often arrive eager for their treatments. Transportation often is available from assisted-living providers, retirement community staff, or municipal programs. A high rate of compliance with all aspects of treatment often offsets a higher prevalence of comorbid (cardiac, vascular, malignancies) conditions in achieving a good outcome. As a result, many elderly patients placed on dialysis continue to enjoy a good quality-of-life and benefit from documented improvement in a variety of health outcome measures.

TABLE

2.2

Renal Physicians Association Clinical Practice Guidelines (for Adult Patients)

Shared Decision Making in the Appropriate Initiation of and Withdrawal from Dialysis

1. Develop a physician–patient relationship for shared decision making
2. Fully inform acute kidney injury (AKI), stages 4 and 5 CKD, and ESKD patients about their diagnosis, prognosis, and all treatment options
3. Give all patients with AKI, stage 5 CKD, or ESKD an estimate of prognosis specific to their overall condition

4. Institute advance care planning
 5. If appropriate, forgo (withhold initiating or withdraw ongoing) dialysis for patients with AKI, CKD, or ESKD in certain, well-defined situations
 6. Consider forgoing dialysis for AKI, CKD, or ESKD patients who have a very poor prognosis or for whom dialysis cannot be provided safely
 7. Consider a time-limited trial of dialysis for patients requiring dialysis, but who have an uncertain prognosis, or for whom a consensus cannot be reached about providing dialysis
 8. Establish a systematic due process approach for conflict resolution if there is disagreement about what decision should be made with regard to dialysis
 9. To improve patient-centered outcomes, offer palliative care services and interventions to all AKI, CKD, and ESKD patients who suffer from burdens of their disease
 10. Use a systematic approach to communicate about diagnosis, prognosis, treatment options, and goals of care
-

D. **Adolescents on dialysis.** There may be significant problems affecting adolescents on hemodialysis or PD. Issues include depression and frustration with medical orders, interpersonal conflicts with family members, poor attendance at school due to frequent hospital admissions, and peer pressure because of inability to participate in school sports. This may manifest as a flat affect (limited social interactions and evasion of communication) and nonadherence to medications, diet, and missed clinic visits. Psychological support and social worker input are key.

II. **DIALYSIS ACCESS PLACEMENT ISSUES.** For hemodialysis, the preferred access is an arteriovenous (AV) fistula. It is important that for all patients for whom renal replacement therapy is anticipated, the veins in both arms should be preserved to the greatest extent possible. All venipunctures should be drawn from the back of the hand where possible. The use of PICC (percutaneous intravenous central catheter) lines should be avoided to the greatest extent possible, as these often result in future access outflow problems. Because some patients have veins that are fragile, creating an access early is important; i.e., 6–9 months before anticipated initiation of dialysis. A lead time of at least 6 months prior to anticipated dialysis may allow correction of suboptimal flow or placement of a second fistula in the event that the initial fistula does not function properly. Vascular access issues are discussed in detail in several chapters of this handbook.

For PD, a peritoneal catheter should be in place at least 2 weeks prior to the anticipated start of dialysis. In the past, an AV fistula was recommended as a fallback option for patients who choose PD. This is no longer recommended but is practiced in some centers. In situations where urgent start of dialysis is needed, a recent trend is to place a peritoneal catheter, which then allows initial control of uremia by PD, and buys time for subsequent placement of an AV fistula.

III. **WHEN TO INITIATE DIALYSIS**

A. **Uremic syndrome.** The uremic syndrome consists of symptoms and signs that result from toxic effects of elevated levels of nitrogenous and other wastes in the blood.

1. **Symptoms.** Uremic patients commonly become nauseated and often vomit soon after awakening. They may lose their appetite such that the mere thought of eating makes them feel ill. They often feel fatigued, weak, and/or cold. Their mental status is altered; at first, only subtle changes in personality may appear, but eventually, the patients become confused and, ultimately, comatose.
 2. **Signs.** Signs of uremia in the modern age are less common, because patients now come to medical attention at a relatively early stage of uremia. Nevertheless, sometimes uremic patients presenting with a pericardial friction rub or evidence of pericardial effusion with or without tamponade may reflect uremic pericarditis, a condition that urgently requires dialysis treatment. Foot- or wrist-drop may be evidence of uremic motor neuropathy, a condition that also responds to dialysis. Tremor, asterixis, multifocal myoclonus, or seizures are signs of uremic encephalopathy. Prolongation of the bleeding time occurs and can be a problem in the patient requiring surgery.
 3. **Signs and symptoms: Uremia versus anemia.** Several of the symptoms and signs previously ascribed exclusively to uremia may be partially due to the associated anemia. When the anemia of anemic CKD patients is improved with erythropoietin, they often experience a marked decrease in fatigue and a concomitant increase in sense of well-being and exercise tolerance. The bleeding time may also improve, and there may be improvement in angina pectoris. There are improvements in cognitive function as well.
 4. **Relationship between uremic syndrome and eGFR.** The uremic syndrome commonly develops when the $\text{eGFR}/1.73 \text{ m}^2$ falls below 8–10 mL/min. However, based on the results of a randomized controlled trial, the so-called “IDEAL” study (Cooper, 2010), a planned earlier start of dialysis (either hemodialysis or PD) was associated with increased costs but was not associated with improved quality-of-life or survival. In the “IDEAL” trial, the average $\text{eGFR}/1.73 \text{ m}^2$ estimated by the MDRD equation in the “early start” group was 9.0 mL/min versus 7.2 mL/min in the “late start” group. There were frequent crossovers in the “late start” group, as the intention was to wait for a lower eGFR to begin dialysis. The results of this trial underscore that, when $\text{eGFR}/1.73 \text{ m}^2$ is around 7 mL/min, symptoms attributable to uremia or fluid overload are not uncommon and such patients are typically deemed to need dialysis by their care providers.
- B. **Indications for dialysis in the chronic setting.** Usually dialysis is initiated in adult patients when the $\text{eGFR}/1.73 \text{ m}^2$ decreases to about 8 mL/min. However, evaluation of the need for dialysis should begin at a higher $\text{eGFR}/1.73 \text{ m}^2$ level, probably around 10–12 mL/min, and sometimes higher. Patients with heart failure and borderline eGFRs may have trouble with refractory fluid retention and may require earlier initiation of dialysis. Conditions that may argue for relatively early initiation of dialysis are listed in Table 2.3.

It should be noted that pericarditis or pleuritis without other cause is an indication for urgent dialysis, particularly pericarditis, where the risk of rapidly developing pericardial effusion and cardiac tamponade is present. Neurologic dysfunction, especially signs of encephalopathy (manifested by asterixis) or uremic neuropathy, is also cause for prompt dialysis, as is prolongation of the bleeding time, which could lead to gastrointestinal or other bleeding. Most of these urgent indications are found in patients who appear with

acute on chronic renal failure. Additional issues pertaining to acute dialysis are discussed in Chapters 10 and 24.

TABLE

2.3

Complications That May Prompt Initiation of Kidney Replacement Therapy^a

- Intractable extracellular volume overload and/or hypertension
- Hyperkalemia refractory to dietary restriction and pharmacologic treatment
- Metabolic acidosis refractory to bicarbonate treatment
- Hyperphosphatemia refractory to dietary counseling and to treatment with phosphorus binders
- Anemia refractory to erythropoietin and iron treatment
- Otherwise unexplained decline in functioning or well-being
- Recent weight loss or deterioration of nutritional status, especially if accompanied by nausea, vomiting, or other evidence of gastroduodenitis

Urgent Indications

-
- Neurologic dysfunction (e.g., neuropathy, encephalopathy, psychiatric disturbance)
 - Pleuritis or pericarditis without other explanation
 - Bleeding diathesis manifested by prolonged bleeding time
-

^aModified from the National Kidney Foundation’s 2006 Kidney Disease Outcomes Quality Initiative (KDOQI) hemodialysis adequacy guidelines.

References and Suggested Readings

Brunori G, et al. Efficacy and safety of a very-low-protein diet when postponing dialysis in the elderly: a prospective randomized multicenter controlled study. *Am J Kidney Dis.* 2007;49:569–580.

Cooper BA, et al. IDEAL Study: a randomized, controlled trial of early versus late initiation of dialysis. *N Engl J Med.* 2010;363:609–619.

Devine PA, Aisling EC. Renal replacement therapy should be tailored to the patient. *Practitioner.* 2014;258:19–22.

FHN Trial Group. In-center hemodialysis six times per week versus three times per week. *N Engl J Med.* 2010;363:2287–2300.

Hussain J, Flemming K, Johnson M. “It’s a lot easier to say yes than no”—decision making in end stage kidney disease. *BMJ Support Palliat Care.* 2014;4(suppl 1):A3.

Iyasere O, Brown EA. Determinants of quality of life in advanced kidney disease: time to screen? *Postgrad Med J.* 2014;90:340–347.

Kallab S, et al. Indications for and barriers to preemptive kidney transplantation: a review. *Transplant Proc.* 2010;42:782–784.

Kupin WR. Pre-emptive kidney transplantation. In: Daugirdas JT, ed. *Handbook of Chronic Kidney Disease Management.* Philadelphia, PA: Wolters Kluwer Health, Lippincott Williams & Wilkins; 2011:511–523.

- Lo WK, et al. Preparing patients for peritoneal dialysis. *Perit Dial Int.* 2008; 28(suppl 3):S69–S71.
- Low J, et al. The experiences of close persons caring for people with chronic kidney disease stage 5 on conservative kidney management: contested discourses of ageing. *Health (London).* 2014.
- Luckett T, et al. Advance care planning for adults with CKD: a systematic integrative review. *Am J Kidney Dis.* 2014;63(5):761–770.
- Mehrotra R, et al. Patient education and access of ESRD patients to renal replacement therapies beyond in-center hemodialysis. *Kidney Int.* 2005;68:378–390.
- Renal Physicians Association. *Shared Decision Making in the Appropriate Initiation of and Withdrawal from Dialysis.* 2nd ed. Rockville, MD: Renal Physicians Association; 2010.
- Shih YC, et al. Impact of initial dialysis modality and modality switches on Medicare expenditures of end-stage renal disease patients. *Kidney Int.* 2005;68:319–329.
- Song MK, et al. Randomized controlled trial of SPIRIT: an effective approach to preparing African-American dialysis patients and families for end of life. *Res Nurs Health.* 2009;32:260–273.
- Traynor JP, et al. Early initiation of dialysis fails to prolong survival in patients with end-stage renal failure. *J Am Soc Nephrol.* 2002;13:2125–2132.

PART II

BLOOD-BASED THERAPIES

Dialysis is a process whereby the solute composition of a solution, A, is altered by exposing solution A to a second solution, B, through a semipermeable membrane. Conceptually, one can view the semipermeable membrane as a sheet perforated by holes or pores. Water molecules and low-molecular-weight solutes in the two solutions can pass through the membrane pores and intermingle, but larger solutes (such as proteins) cannot pass through the semipermeable barrier, and the quantities of high-molecular-weight solutes on either side of the membrane will remain unchanged.

- I. **MECHANISMS OF SOLUTE TRANSPORT.** Solutes that can pass through the membrane pores are transported by two different mechanisms: diffusion and ultrafiltration (convection).
 - A. **Diffusion.** The movement of solutes by diffusion is the result of random molecular motion. The larger the molecular weight of a solute, the slower will be its rate of transport across a semipermeable membrane. Small molecules, moving about at high velocity, will collide with the membrane often, and their rate of diffusive transport through the membrane will be high. Large molecules, even those that can fit easily through the membrane pores, will diffuse through the membrane slowly because they will be moving about at low velocity and colliding with the membrane infrequently (Fig. 3.1).
 - B. **Ultrafiltration.** The second mechanism of solute transport across semipermeable membranes is ultrafiltration (convective transport). Water molecules are extremely small and can pass through all semipermeable membranes. Ultrafiltration occurs when water driven by either a hydrostatic or an osmotic force is pushed through the membrane (Fig. 3.1). Those solutes that can pass easily through the membrane pores are swept along with the water (a process called “solvent drag”). The water being pushed through the membrane is accompanied by such solutes at close to their original concentrations. Analogous processes are wind sweeping along leaves and dust as it blows and current in the ocean moving both small and large fish as it flows. Larger solutes, especially those that are larger than the membrane pores, are held back. For such large solutes, the membrane acts as a sieve.

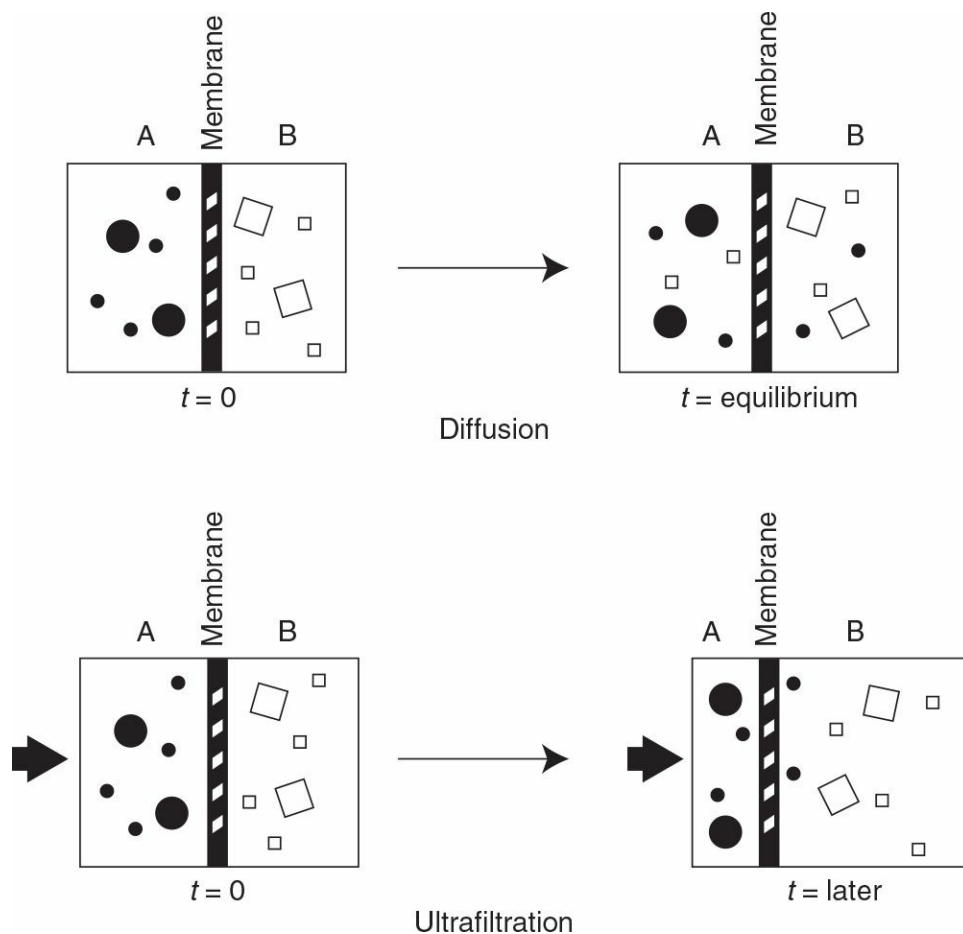

FIGURE 3.1 The processes of diffusion (**top**) and ultrafiltration (**bottom**). As shown, in both processes, low-molecular-weight solutes can cross the semipermeable membrane, whereas larger solutes are held back.

1. Hydrostatic ultrafiltration

- a. **Transmembrane pressure.** During hemodialysis, water (along with small solutes) moves from the blood to dialysate in the dialyzer as a result of a hydrostatic pressure gradient between the blood and dialysate compartments. The rate of ultrafiltration will depend on the total pressure difference across the membrane (calculated as the pressure in the blood compartment minus the pressure in the dialysate compartment).
 - b. **Ultrafiltration coefficient (K_{UF}).** The permeability of dialyzer membranes to water, though high, can vary considerably and is a function of membrane thickness and pore size. The permeability of a membrane to water is indicated by its ultrafiltration coefficient, K_{UF} . K_{UF} is defined as the number of milliliters of fluid per hour that will be transferred across the membrane per mm Hg pressure gradient across the membrane.
2. **Osmotic ultrafiltration.** Osmotic ultrafiltration is described in Chapter 21.
 3. **Purpose of ultrafiltration.** Ultrafiltration during dialysis is performed for the purpose of removing water accumulated either by ingestion of fluid or by metabolism of food during the interdialytic period. Typically, a patient being dialyzed thrice weekly will gain 1–4 kg of weight between treatments (most of it water), which will need to be removed during a 3–4-hour period of dialysis. Patients with acute fluid overload may

need more rapid fluid removal. Thus, the clinical need for ultrafiltration usually ranges from 0.5 to 1.2 L/hr.

4. Use of ultrafiltration to enhance solute clearance

a. **Hemofiltration and hemodiafiltration.** Whereas diffusive removal of a solute depends on its size, all ultrafiltered solutes below the membrane pore size are removed at approximately the same rate. This principle has led to use of a technique called *hemofiltration*, whereby a large amount of ultrafiltration (more than is required to remove excessive fluid) is coupled with infusion of a replacement fluid in order to remove solutes. Although hemodialysis and hemofiltration often show comparable removal of small solutes such as urea (MW 60), hemofiltration can effect much higher removal of larger, poorly diffusible solutes, such as inulin (MW 5,200). Sometimes hemodialysis and hemofiltration are combined. The procedure is then called *hemodiafiltration*.

C. **Removal of protein-bound compounds.** The normal kidney detoxifies protein-bound organic acids and bases. Being protein bound, they are filtered to only a small extent and so bypass the glomerulus (Sirich, 2013). However, in the peritubular capillary network, these substances are removed from albumin and are taken up by proximal tubular cells. Then they are secreted into the tubular lumen, to be excreted in the urine. Other protein-bound compounds (bound to albumin and small proteins) are filtered in the glomerulus along with their carrier proteins. In the proximal tubule, the filtered proteins are catabolized along with their bound compounds.

The plasma concentration of such protein-bound substances is markedly elevated in dialysis patients (Sirich, 2013), but the association between high blood levels of these compounds and mortality is not completely clear (Melamed, 2013). Removal of protein-bound compounds by hemodialysis depends on the percentage of the “free” fraction of the compound in plasma (the fraction that is exposed to dialysis). Also, removal depends on how quickly the free fraction is replenished by the protein-bound pool. Substances that are tightly bound to proteins with a low free fraction in the plasma will be removed to a small extent by conventional hemodialysis.

II. **SOLUTE REMOVAL FROM THE PERSPECTIVE OF THE DIALYZER.** In clinical use, the box containing two solutions in Figure 3.1 becomes the dialyzer, containing blood and dialysis solution. The latter consists of highly purified water to which sodium, potassium, calcium, magnesium, chloride, bicarbonate, and dextrose have been added. The low-molecular-weight waste products that accumulate in uremic blood are absent from the dialysis solution. When uremic blood is exposed to dialysis solution, the flux rate of these waste solutes from blood to dialysate is initially much greater than the back-flux from dialysate to blood. Eventually, if the blood and dialysate were left in static contact with each other via the membrane, the concentration of permeable waste products in the dialysate would become equal to that in the blood, and no further net removal of waste products would occur. Transport back and forth across the membrane would continue, but the rates of transport and back-transport would be equal. In practice, during dialysis, concentration equilibrium is prevented, and the concentration gradient between blood and dialysate is maximized, by continuously refilling the dialysate compartment

with fresh dialysis solution and by replacing dialyzed blood with undialyzed blood. Normally, the direction of dialysis solution flow is opposite to the direction of blood flow (Fig. 3.2). The purpose of “countercurrent” flow is to maximize the concentration difference of waste products between blood and dialysate in all parts of the dialyzer.

A. **Extraction ratio.** Figure 3.3 shows a schematic of a dialyzer and its effects on the serum urea nitrogen (SUN) concentration of blood entering and leaving the dialyzer. The extraction ratio is the percentage reduction of urea (or any other solute) across the dialyzer. In the case shown, with blood flow rate (Q_B) of 400 mL/min, the inlet SUN (blood urea nitrogen) is 100 mg/dL and the outlet concentration is 40 mg/dL; hence, the extraction ratio is 60% $(100 - 40)/100$. The extraction ratio is not affected by the inlet SUN level. Under the same conditions, if the inlet SUN were 200 mg/dL, the outlet SUN would be 80, and if the inlet SUN were 10, the outlet SUN would be 4.

The extraction ratio is affected by the rate of blood flow through the dialyzer (Fig. 3.4). If blood flow rate were reduced from 400 to 200 mL/min, the outlet SUN would decrease from 40 to 12 mg/dL. If blood flow rate were reduced to 1 mL/min, the outlet SUN would be very low, about 1 mg/dL, and if a very high rate of blood flow were used, 20 L/min, the outlet SUN would increase to about 97 mg/dL. The faster the blood flows through the dialyzer, the less time it spends in the filter. The dialyzer blood compartment volume is about 100 mL, so at a flow rate of 400 mL/min, the blood is spending about 15 seconds in the dialyzer. On reducing the flow to 200 mL/min, the transit time doubles, to 30 seconds, and because of this, the blood has more time to be “cleaned,” and the SUN in the blood exiting the dialyzer is only 12 mg/dL. On reducing flow to 1 mL/min, the blood would spend a full 100 minutes in the dialyzer, and the outlet blood would have a very low concentration of urea nitrogen. On the other hand, at a very rapid flow rate, much higher than could be achieved in practice, say 20,000 mL/min, the blood would spend only 0.3 seconds in the dialyzer. Still, the outlet SUN would be lower than the inlet and might be about 97 mg/dL. In effect, the dialyzer is a “washing machine,” and the less time the blood spends in the machine, the lower the percentage of waste products removed from a given volume of blood.

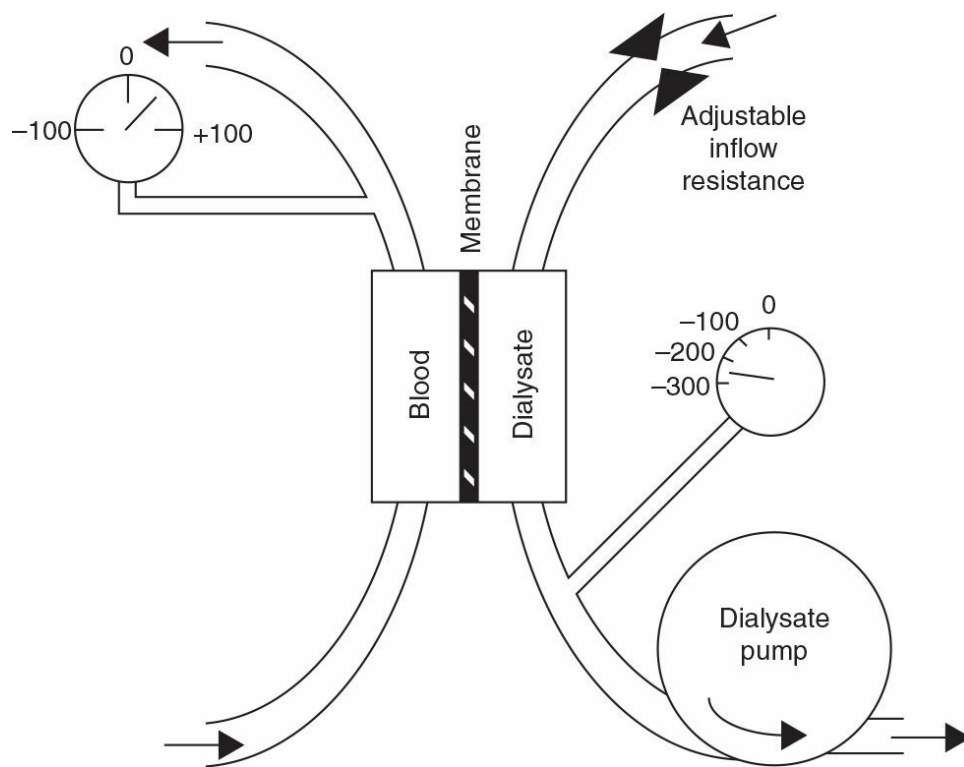
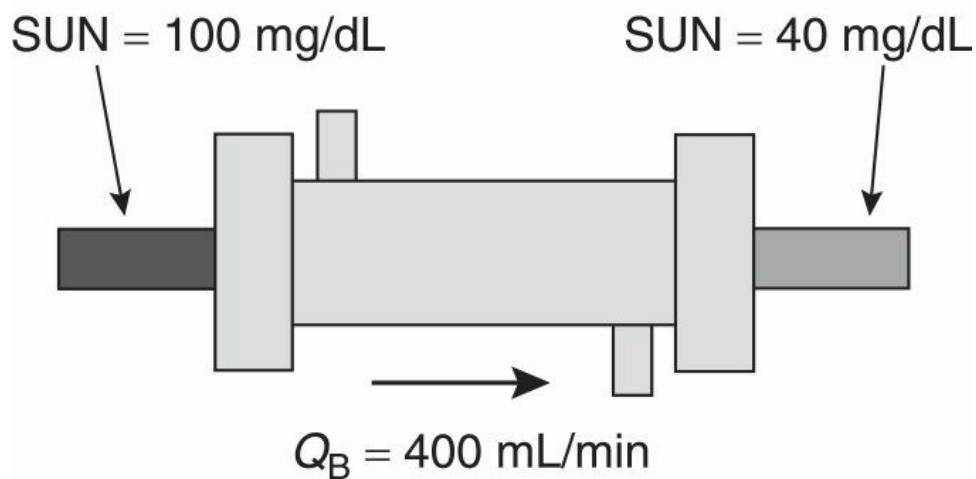

FIGURE 3.2 A dialyzer with blood flowing in one direction and dialysis solution flowing in the opposite direction. Hydrostatic pressure across the membrane (and ultrafiltration) is adjusted by varying the resistance to inflow of dialysis solution.

What is the extraction ratio?



Extraction ratio = (inlet – outlet)/inlet
 = (100 – 40)/100 = 60%

FIGURE 3.3 The dialyzer extraction ratio for urea as a function of inlet and outlet urea concentration.

What is the effect of Q_B on ER?

The higher the Q_B , the lower the ER
The lower the Q_B , the higher the ER

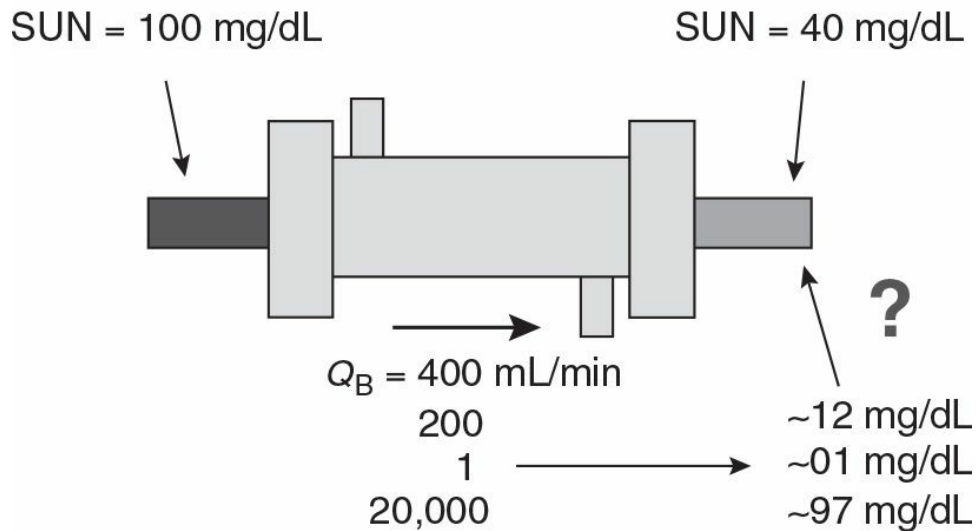

FIGURE 3.4 Effect of blood flow rate on the outlet SUN.

- B. **Concept of clearance.** As shown in Figure 3.5, the blood exiting the dialyzer can be considered in one of two ways. One can consider the entire volume and the percentage reduction of solute in that volume, or one can separate out the flow exiting the dialyzer into two streams—in the first stream, the concentration of solute will be the same as the inlet concentration, and in the second stream, all urea nitrogen will have been removed. One can think of an extraction ratio or reduction in SUN of 60% for the combined outlet stream, or one can consider that 60% of the fluid flowing through the dialyzer has been completely cleared of urea. If we mix the unchanged stream with the cleared stream, the concentration of urea nitrogen in the mixed stream will be reduced by 60% relative to that in the dialyzer inlet. One can calculate what the relative flow rates of the unchanged stream and the cleared stream would need to be to achieve mass balance. In this case, the flow rate of the cleared stream is simply 60% of the inlet flow rate. If the inlet flow rate is 400 mL/min, the flow rate of the cleared stream would be $0.60 \times 400 = 240 \text{ mL/min}$, and the flow rate of the unchanged stream would be 160 mL/min. Thus, a dialyzer extraction ratio of 60% translates into a dialyzer clearance of $0.6 \times$ blood inflow rate (Q_B), or 240 mL/min. Clearance is usually abbreviated as “ K ” or “ K_D .” Flow rate is abbreviated as “ Q ,” and blood flow rate is abbreviated as “ Q_B ,” and dialysate flow rate as “ Q_D .”

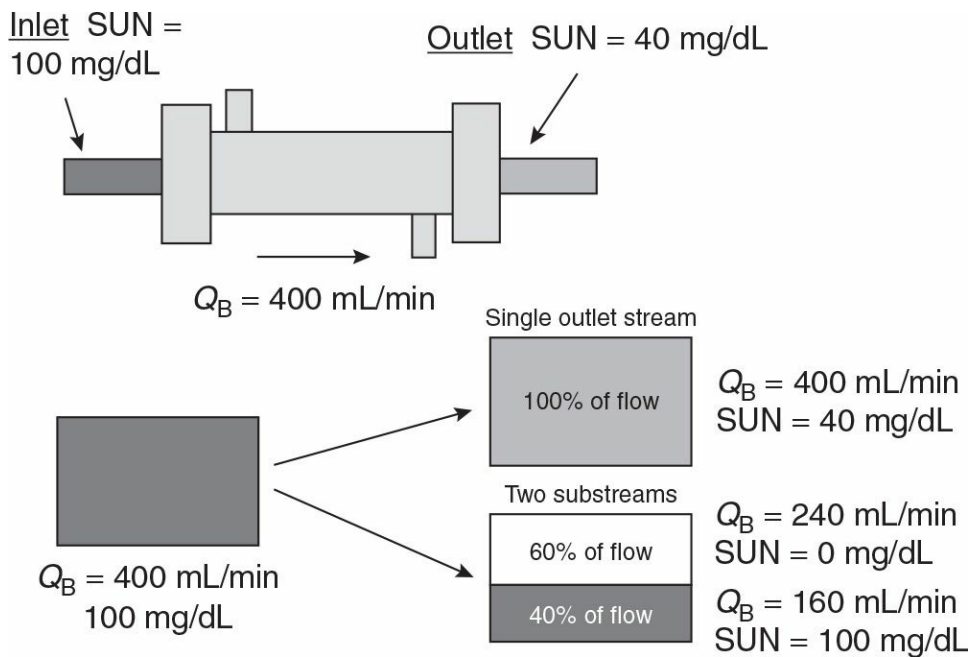

FIGURE 3.5 Concept of dialyzer clearance. The blood exiting the dialyzer can be looked at in two ways: (1) as one outlet stream where the solute concentration has been reduced by 60% (from 100 to 40 mg/dL) or (2) as two substreams: in one substream the solute concentration is unchanged, and in the other substream the solute has been completely removed. The flow rate of the cleared substream is the dialyzer “clearance” and is equal to the extraction ratio multiplied by the blood flow rate.

1. **Effect of dialyzer blood flow rate on clearance.** We now can look at the effects of blood flow (Q_B) on dialyzer clearance (K_D). From Table 3.1, we see that when blood flow is very low, 50 mL/min, the blood in the dialyzer is cleaned very well, due to a long residence time in the dialyzer, and the outlet SUN is only 1 mg/dL, with an extraction ratio of 99%. However, the amount of blood cleared is limited by the flow rate of 50 mL/min; although 99% of the blood is cleared, 99% of 50 mL/min is a low number. When the blood flow rate is increased, the blood is only partially cleared of urea due to less time spent in the dialyzer, but even though the extraction ratio falls as blood flow rate is increased, the volume of blood cleared of urea nitrogen keeps increasing as the blood flow rate is increased. Ultimately, when blood flow rate is very high, 20 L/min, the clearance in this particular example is 600 mL/min, even though only 3% of the inlet SUN is removed.
2. **The K_0A , mass transfer area coefficient.** If the extraction ratio remained constant at 60%, a doubling of the blood flow rate would double the clearance. However, removal efficiency falls at higher blood flow rates, and so the clearance does not increase with Q_B in a 1:1 ratio. Ultimately, at very high blood flow rate, the clearance will plateau. The theoretical maximum clearance of a dialyzer (for a given solute) at infinite blood and dialysate flow rates is called the K_0A and has units of mL/min. For the dialyzer in Table 3.1, the K_0A is close to 600 mL/min. The K_0A also has a physical aspect. It is the multiple of two quantities: K_0 , the permeability coefficient of the dialyzer membrane for a given solute, and A , the total effective surface area of the membrane in the dialyzer. Doubling the surface area of the membrane in a dialyzer will roughly double

the K_0A . Two dialyzers of the same surface area do not necessarily have the same K_0A , as the K_0 values of the membranes used in those dialyzers can be markedly different. The K_0 can be increased by making the membrane thinner, by adjusting its porosity, and by optimizing the fluid path of dialysate in the dialyzer using spacer yarns and other features.

TABLE

3.1

Effect of dialyzer blood flow rate on extraction ratio and clearance (inlet SUN = 100 mg/dL)

Q_B (mL/min)	Outlet SUN (mg/dL)	Extraction Ratio (ER, %)	K_D (ER \times Q_B)
50	1	99	50
200	12	88	176
400	40	60	240
500	48	52	260
20,000	97	3	600

Figure 3.6 shows the relationship between blood flow rate (Q_B) on the horizontal axis and expected dialyzer clearance (K_D) on the vertical axis. Each isopleth (curved line) represents a different efficiency dialyzer, where dialyzer efficiency is expressed as dialyzer K_0A . The values of K_0A in Figure 3.6 range from 300 to 1,600 mL/min. Most dialyzers in common use today for adults have K_0A values of 800–1,600. This figure shows that as the blood flow is increased, the clearance increases, but the increase tends to level off. You can see that when Q_B is low (\sim 200 mL/min), dialyzers in the 800–1,600-mL/min K_0A range have similar clearances. This is because at this low blood flow rate, they are each extracting almost all of the urea in the blood entering the dialyzer. The benefits of a “high-efficiency” (high K_0A) dialyzer become apparent primarily when the blood flow rate is high. Then the larger dialyzers with thinner, more efficient membranes are able to keep the extraction rate high, maximizing the increase in dialyzer clearance.

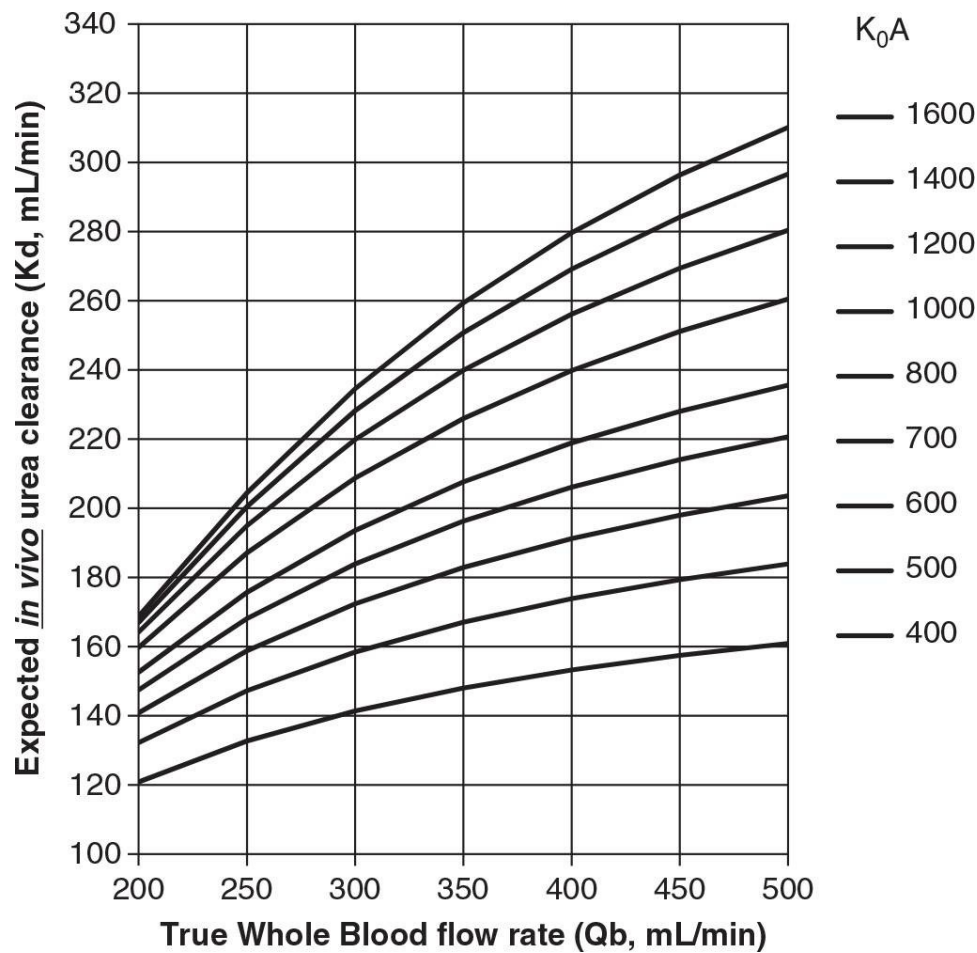

FIGURE 3.6 Relationship between blood flow rate (Q_B) and dialyzer blood water urea clearance (K) as a function of dialyzer efficiency (K_0A). Each isopleth (curved line) represents a different dialyzer having a different K_0A value. To use the nomogram, find the blood flow rate on the horizontal axis, then move up to the dialyzer K_0A being used, and read of the expected dialyzer urea clearance on the vertical axis. Theoretical clearance values have been adjusted to more closely reflect expected values in vivo.

3. **Calculating the solute removal rate.** For a situation where a uniform solution is running through the dialyzer, one can calculate the removal rate (in mg/min or mmol/min) of a given solute. For example, if the inlet SUN is 1 mg/mL and we are clearing 240 mL/min of blood of urea, then we are removing 240 mg/min of urea nitrogen from the patient.
4. **Effect of erythrocytes.** In the concept of clearance described earlier, the blood was treated as a simple fluid. However, this is not the case. At a hematocrit of 30%, a blood flow of 400 mL/min is really a plasma flow rate of 280 mL/min and an erythrocyte flow rate of 120 mL/min. What is measured at the dialyzer inlet and outlet are the plasma levels of a given waste product. For urea, the presence of erythrocytes is not a major problem because urea diffuses into and out of erythrocytes quickly. For example, if the outlet plasma urea nitrogen level is 40 mg/dL, the urea concentration in erythrocytes will have been reduced to about that level also. For creatinine and phosphorus and many other solutes, the problem is more complex because these substances do not equilibrate quickly between plasma and erythrocytes. In fact, very little creatinine or phosphorus is

removed from red blood cells during passage through the dialyzer. When calculating the removal rate of creatinine or phosphorus in mg/min or mmol/min, one needs to use the plasma flow rate instead of the blood flow rate.

5. **Effect of blood water.** As noted, urea is dissolved in erythrocytes and plasma water and is removed from both during passage through the dialyzer. Approximately 93% of plasma is water (depending on its protein concentration), and about 72% of an erythrocyte is water. Some urea associates with the nonwater portion of erythrocytes. On average, urea is dissolved in a volume that is about 86% of the blood. The correction for blood water becomes important when using the dialyzer clearance to compute how much urea is being removed during a dialysis session.

For solutes like creatinine and phosphorus that are removed from the plasma compartment only passage through the dialyzer, the volume of removal is about 93% of the plasma flow rate. Increasing the hematocrit (e.g., from 20% to 40%) causes only a trivial reduction of the blood water urea clearance but will be associated with a noticeable reduction in the clearance of creatinine or phosphorus, due to the effect of hematocrit on the plasma flow rate.

6. **Effect of dialysis solution flow rate.** Dialyzer clearance of urea (and other solutes) depends on the dialysis solution flow rate as well. A faster dialysis solution flow rate increases the efficiency of diffusion of urea from blood to dialysate although the effect is usually modest. The usual dialysis solution flow rate is 500 mL/min. A flow rate of 800 mL/min will increase urea clearance by about 5%–8% when a high-efficiency dialyzer is used and when the blood flow rate is greater than 350 mL/min. On the other hand, in some daily, nocturnal, or intensive care unit (ICU)–based applications, dialysate flow rate is markedly lower than 500 mL/min. Such a reduced dialysate flow rate can cause substantial reduction in dialyzer clearance. The optimum dialysis solution flow rate is 1.5–2.0 times the blood flow rate. Above that, the increase in efficiency is quite small, especially with some of the newer dialyzers where the dialysis solution flow path has been optimized.
7. **Effect of molecular weight on diffusive clearance.** Because high-molecular-weight solutes move slowly through solutions, they diffuse poorly through the membrane. As a result, the extraction ratio for molecules larger than urea will be less than that of urea; plus, to calculate clearance, this lower extraction ratio must be multiplied by the plasma flow rate, and not the blood flow rate.
8. **Very large molecules.** Very large molecules, such as β_2 -microglobulin (MW 11,800), cannot get through the pores of standard (low-flux) dialysis membranes at all. Thus, dialyzer clearance of β_2 -microglobulin will be zero! “High-flux” membranes have pores of sufficient size to pass this large molecule. Also, some dialysis membranes remove β_2 -microglobulin by adsorption.
9. **Dialyzer efficiency versus flux.** When we speak of dialyzer efficiency, we refer primarily to the ability of a dialyzer to remove small solutes. The dialyzer efficiency is best represented by the K_0A for urea. The flux of a dialyzer refers to its ability to remove very large molecules such as β_2 -microglobulin. There is no single measure in common

use to specify the flux of a dialyzer, though water permeability (K_{UF}) can be used. Usually high-flux dialyzers will have a water permeability greater than 15–20 mL/hr per mm Hg. One can have a small, low-efficiency ($K_0A = 400$ mL/min) dialyzer (e.g., for use in children) that is high flux, or a high-efficiency dialyzer ($K_0A = 1,200$ mL/min) that is low flux and that removes urea very well but that removes no β_2 -microglobulin.

III. SOLUTE REMOVAL FROM THE PATIENT PERSPECTIVE

- A. **Importance of urea.** Measurement of solute removal during hemodialysis focuses on urea. Urea is manufactured by the liver from amino acid nitrogen via ammonia and is the principal way in which nitrogenous waste products are excreted from the body. Urea is a small molecule, with a molecular weight of 60 Da. It is only slightly toxic. Urea generation occurs in proportion to protein breakdown as reflected in the protein nitrogen appearance (PNA) rate. In stable patients, the PNA is proportional to dietary protein intake. Using a mathematical model known as urea kinetics, one can compute both the rate of removal and production of urea. The extent of urea removal gives us a measure of the adequacy of dialysis, and the amount of urea nitrogen generation gives an estimate of dietary protein intake.
- B. **The weekly serum urea nitrogen profile.** As a result of dialysis, the predialysis SUN level is typically reduced by about 70% so that postdialysis SUN is 30% of the predialysis value. During the subsequent interdialytic period (assuming a thrice-weekly dialysis schedule), the SUN will rise to almost the same level as that seen prior to the first treatment. The result is a sawtooth pattern. The time-averaged (TAC) SUN level can be computed mathematically as the area under the sawtooth curve divided by time. Both the predialysis SUN and TAC SUN levels reflect the balance between urea production and removal. For a given level of dialysis therapy, predialysis SUN and TAC SUN will rise if urea nitrogen generation (g) is increased and will fall if g is decreased. Also, for any given rate of urea nitrogen generation, predialysis SUN and TAC SUN levels will rise if the amount of dialysis is decreased or will fall if the amount of dialysis is increased.
- C. **Pitfalls in targeting a predialysis SUN or TAC SUN.** Early attempts to model dialysis adequacy focused on predialysis SUN or on the TAC SUN. Therapy was thought to be adequate as long as predialysis or TAC SUN was appropriately low. However, low predialysis or TAC SUN levels were found to be associated with a high mortality rate and were found to most often reflect inadequate protein intake rather than adequate dialysis.
- D. **Indices of urea removal**
1. **Urea reduction ratio (URR).** The current primary measure of dialysis adequacy is the treatment-related URR. This is computed as follows: Assume that predialysis SUN is 60 mg/dL and postdialysis SUN is 18 mg/dL. The relative reduction in SUN (or urea) level is $(60 - 18)/60 = 42/60 = 0.70$. By convention, URR is expressed as a percentage, so the value of the URR in this example would be 70%.

SI units: Assume that predialysis serum urea is 21 mmol/L and postdialysis is 6.4 mmol/L. The relative reduction in SUN (or urea) level is $(21 - 6.4)/21 = 14.6/21 = 0.70$.

2. **Kt/V urea.** The Kt/V urea was popularized by Gotch and Sargent in their reanalysis of the National Cooperative Dialysis Study (1985). In that study, a urea Kt/V value <0.8 was found to be associated with a high likelihood of morbidity and/or treatment failure, while a $Kt/V >1.0$ was associated with a good outcome. Largely because of this study, guidelines groups have recommended a minimum Kt/V value of at least 1.2 for hemodialysis patients being dialyzed three times per week.

The Kt/V urea is a dimensionless ratio representing volume of plasma cleared of urea (Kt) divided by the urea distribution volume (V). K is the dialyzer blood water urea clearance (L/hr), t is dialysis session length (hours, hr), and V is the distribution volume of urea (liters, L), which is close to total body water.

$$K \times t = \text{L/hr} \times \text{hr} = \text{L}$$

$$V = \text{L}$$

$$(K \times t)/V = \text{L/L} = \text{dimensionless ratio}$$

If we deliver a Kt/V of 1.0, this implies that $K \times t$, or the total volume of blood cleared during the dialysis session, is equal to V , the urea distribution volume.

3. **How URR is related to Kt/V .** To understand this best, consider Figures 3.7 through 3.14. In a fishtank analogy (Fig. 3.7), if one removes a fish from a 40-L tank, drains half (20 L) of the volume and replaces the drained fluid with 20L of clean water, the replaced and cleared volume can be thought of as Kt . The volume of the tank is 40 L, so the Kt/V is 20/40 or 0.5. The fish waste reduction ratio will be 50% after the 20 L of clean water is mixed with 20 L of uncleaned water. In this situation, $Kt/V = \text{fish waste reduction ratio} = 0.5$. In Figure 3.8, we clean the tank more completely. On removing the fish, the entire 40 L (V) is drained and replaced with clean water. Then the fish is replaced. In this case, the cleared volume is 40 L, $V = 40$ L, and $Kt/V = 40/40 = 1.0$, and the fish waste reduction ratio is 100%. In this model, a Kt/V of 1.0 is a “perfect” dialysis or cleaning; one that cannot be improved upon.

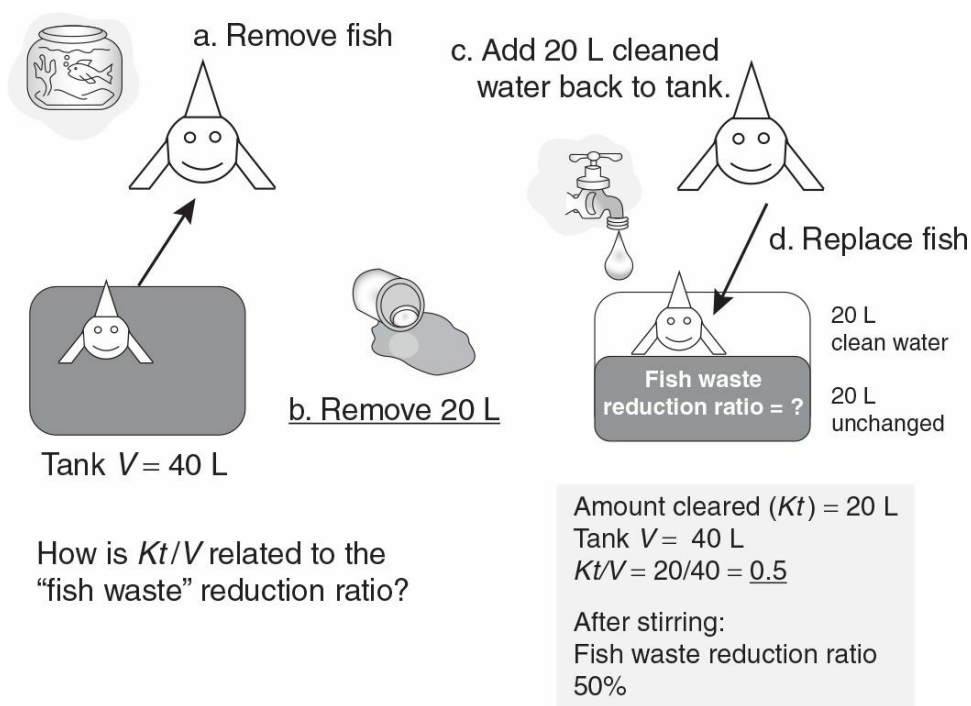

FIGURE 3.7 Fractional clearance of 50% ($Kt/V = 0.5$) in a fish tank model with the fish removed during cleaning. Note the fish waste reduction ratio is 50%, equal to the Kt/V .

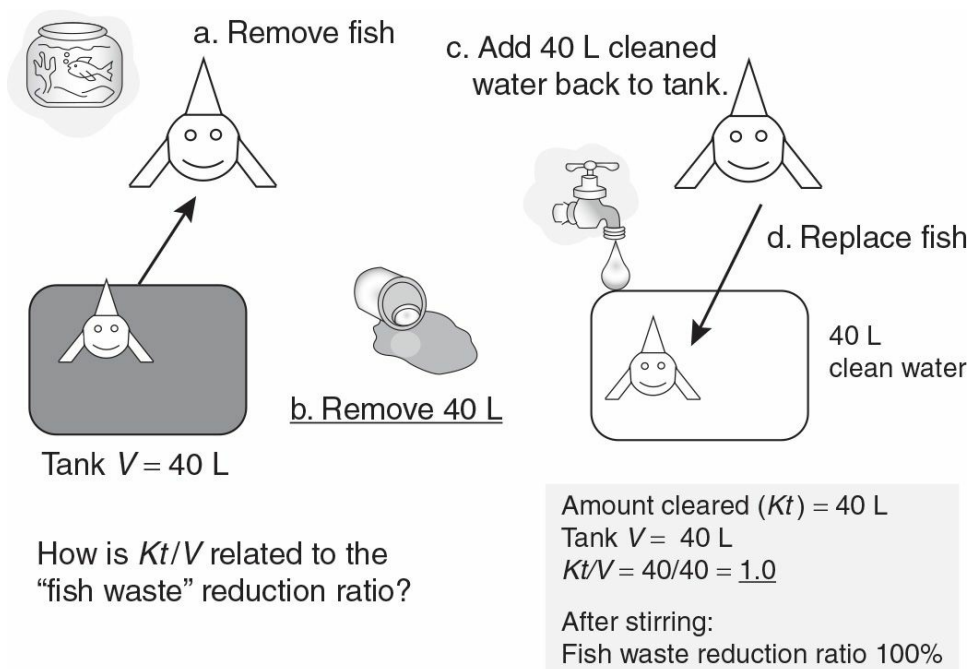

FIGURE 3.8 Fractional clearance of 100% ($Kt/V = 1.0$) in a fish tank model with the fish removed during cleaning. The fish waste reduction ratio is 100%, equal to the Kt/V .

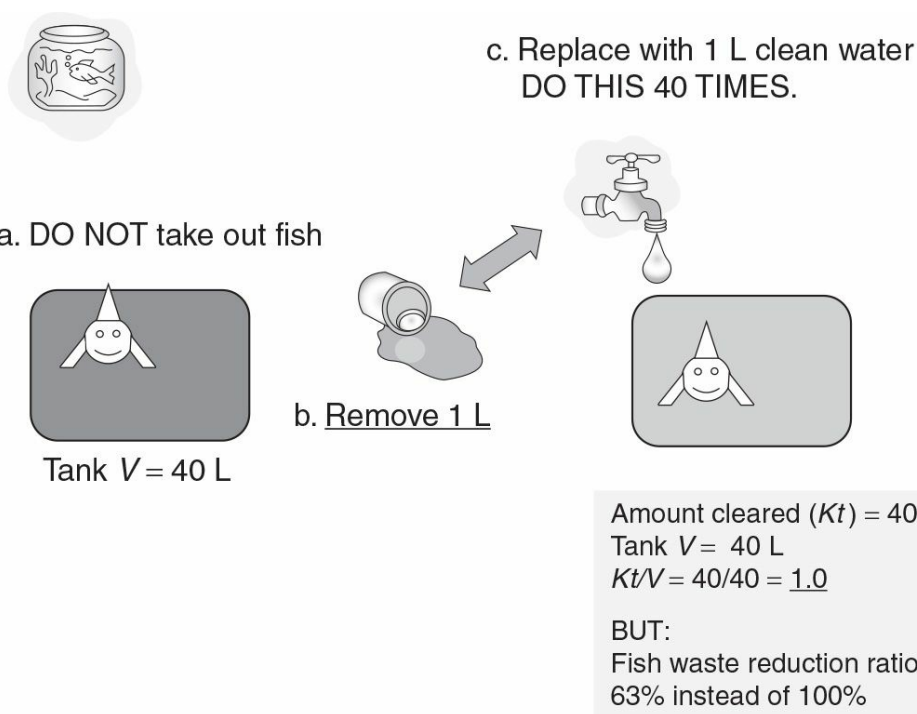

FIGURE 3.9 Fractional clearance of 100% ($Kt/V = 1.0$) in a fish tank model with the fish left in place during tank cleaning. In this situation, the fish waste reduction ratio is only 63%.

A markedly different situation is shown in Figure 3.9. In this case, the cleaning takes place without removing the fish from the tank. With a 1-L cup, one removes 1 L of dirty water and replaces it with 1 L of clean water. Taking out only a small volume at a time keeps the fish happy and allows it to stay in the tank during cleaning. If one does this 40 times, then a total of 40 L (40×1 L) will have been “cleared,” and the Kt will be 40. As the V is also 40, the Kt/V will again be $40/40$, or 1.0. However, in this situation, the fish waste reduction ratio will be only 63% instead of 100%. Why is this? With each 1-L remove/replace cycle, the concentration of fish waste in the tank gets reduced so that the subsequent 1-L remove/replace cycle removes less fish waste than the cycle before. The progressive dilution of fish waste in the tank during this cleaning process reduces the efficiency of the process, and in this case, a Kt/V of 1.0 is no longer a perfect cleaning, and substantial fish waste remains in the tank at the end.

Figures 3.10 and 3.11 show this in a more formal sense. In Figure 3.10, we show a situation analogous to Figure 3.7, where the fish has been removed from the tank during cleaning. Here we consider a source tank containing 40 L, and a “perfect” dialyzer, such that the outlet SUN is always zero. The starting UN concentration in the source tank is 80 mg/dL. In Figure 3.10, the cleaning process is discontinuous. Cleaned fluid is collected in a separate holding tank, and the UN concentration of the cleaned fluid is zero. If one runs 20 L through this ideal dialyzer, then Kt is 20, and on adding this cleaned fluid back to the source tank, the URR will be 50%. If one runs 40 L through the ideal dialyzer, then the Kt volume is 40 L; on adding this completely cleaned fluid back to the source tank, the URR will be 100%. The bottom panel of Figure 3.10 shows a graph of the relationship between URR and Kt/V and it is simply $URR = Kt/V$. The middle panel shows the concentration of UN in the fluid entering the dialyzer from the source tank as dialysis progresses. The inlet SUN stays at 80 mg/dL

throughout the dialysis, making this process extremely efficient.

Figure 3.11 shows the situation similar to when the fish remains in the tank. In this situation, the UN concentration of the fluid exiting the dialyzer is still zero, but the dialyzer outlet fluid is routed back to the source tank. This results in a continuous dilution of the UN concentration in the source tank as dialysis progresses, and the inlet UN of the dialyzer over time decreases as shown in the middle panel. The system with continuous fluid return is far less efficient than when fluid is kept in a holding tank until the end of dialysis. With this new arrangement, even after running all 40 L through our ideal dialyzer ($Kt/V = 1.0$), even though the outlet SUN has been zero, there still will be urea left in the tank. The bottom panel in Figure 3.11 shows the relationship between URR and Kt/V . Similar to the fishtank analogy, when Kt/V is 1.0, the URR will be 0.63. Even if we run all 40 L through a second ($Kt/V = 2.0$) and a third ($Kt/V = 3.0$) time, the postdialysis SUN still will not be zero and the URR still will not be 100%. Because of this dilution factor, long dialysis sessions become progressively less efficient in removing small-molecular-weight solutes as the session continues.

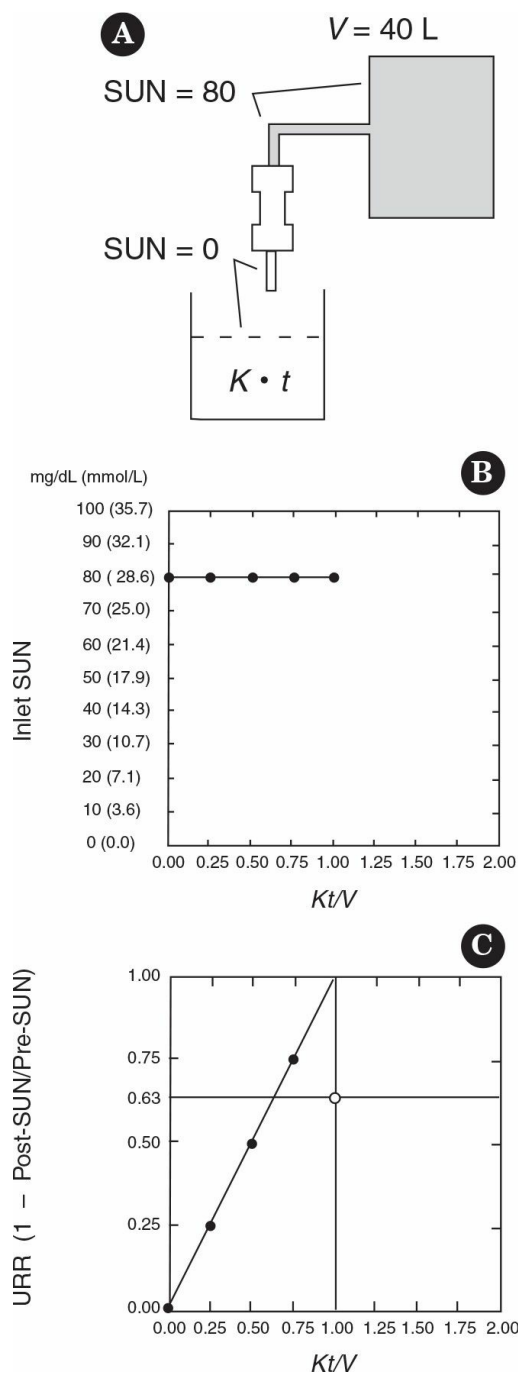

FIGURE 3.10 A: A fixed-volume model of urea removal (no urea generation) in which fluid from the dialyzer is routed to a holding tank and is mixed with the source “body” tank only at the end of dialysis. In this cartoon, blood flow rate is equal to dialyzer clearance as we are assuming a perfect dialyzer. **B:** The dialyzer inlet SUN (i.e., blood urea nitrogen) remains constant (80 mg/dL [~ 28 mmol/L] in this example) throughout dialysis. **C:** In this model, $Kt/V = \text{URR}$ and $Kt/V = 1.0$ represents a perfect dialysis (all toxins removed). (Reproduced from Daugirdas JT. Urea kinetic modeling tutorial. *Hypertens Dial Clin Nephrol*. Available at: <http://www.hdcn.com>.)

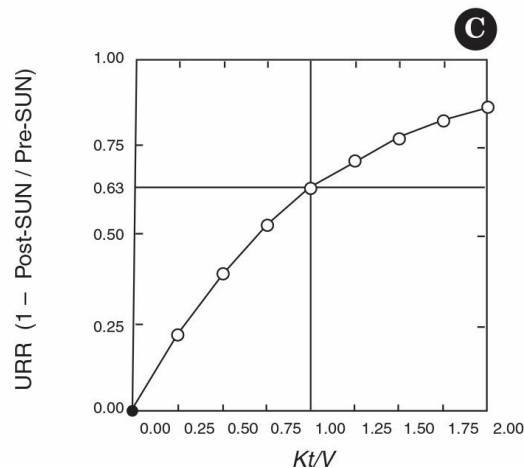
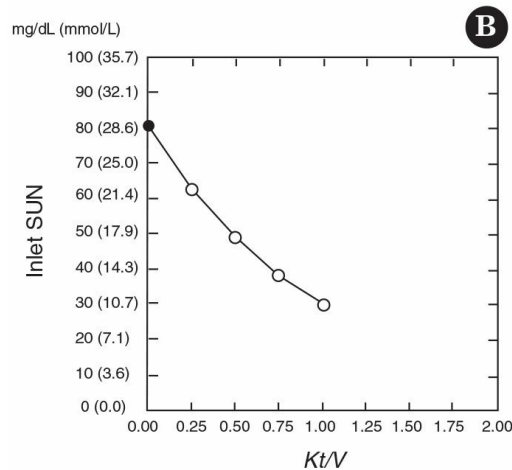
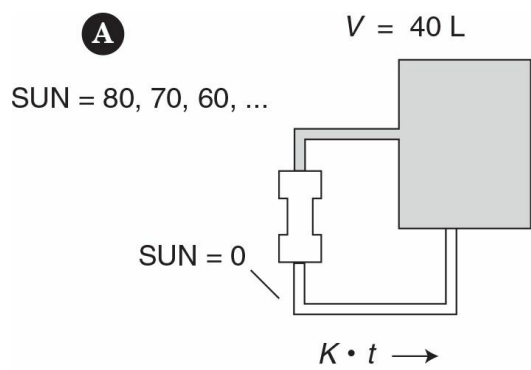

FIGURE 3.11 A: Another fixed-volume model, except this time the dialyzer outlet fluid is continually returned to the source tank throughout dialysis. As shown in **B**, the inlet SUN now falls exponentially during dialysis, reducing dialysis efficiency. **C:** With continuous outlet return, a URR of only 0.63 is reached when the total tank volume (V) is passed through the dialyzer, making $Kt/V = 1.0$. (Reproduced from Daugirdas JT. Urea kinetic modeling. *Hypertens Dial Clin Nephrol*. Available at: <http://www.hdcn.com>.)

4. **Effect of urea generation.** In Figure 3.12, we are back to cleaning the fishtank. If one removes 40 L, one liter at a time $\times 40$, and we do this quickly, the fish waste reduction ratio will be 63%, as discussed earlier. However, if we clean the tank *slowly*, while we are cleaning the tank, the fish in the tank continues to generate waste. If the “dialysis” or fish tank cleaning takes 2 hours, we expect a fish waste reduction ratio of 63%, but find instead a reduction ratio of only 61.5%, due to the additional waste added to the tank by the fish during the 2-hour cleaning period. Similarly, if the

cleaning takes 4 or 8 hours, a Kt/V of 1.0 will result in a waste reduction ratio of only 60% or 57%, respectively. Finally, if the 40 L is replaced very slowly, over 24 hours, then we have a continuous renal replacement type of treatment, where a Kt/V of 1.0 per day results in a waste reduction ratio of close to 0%. This means that although URR and Kt/V are mathematically related, one needs to take the length of the dialysis session into account.

5. **Additional Kt/V associated with volume removal.** Kt/V by convention is based on the *postdialysis* value for V . Commonly during dialysis, some fluid is removed, such that postdialysis V will be several liters lower than the starting value. Along with fluid volume reduction, some wastes are removed, and this removal is not reflected by a change in concentration. To understand this better, consider the extreme case shown in Figure 3.13. Here we start with a fishtank that has a volume of 80 L. We simply drain 40 L and do not replace any fluid. We have “cleared” (Kt) 40 L, and the postdialysis volume of the fishtank now is 40 L, so Kt/V is $40/40 = 1.0$, but the waste reduction ratio is zero. Thus, in the course of volume reduction, we always get some additional Kt/V that is not reflected in the waste reduction ratio.

Effect of urea generation on Kt/V vs. URR (fish making waste while tank is being cleaned)

- If you replace 40×1 L, expected URR is 63%
- If you do this quickly, URR = 63%
- Over 2 hours: URR ~61.5%
- Over 4 hours: URR ~60%
- Over 8 hours: URR ~57%
- Continuously (CRRT): URR = 0%

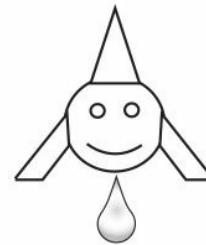

FIGURE 3.12 Effect of dialysis session length on the relationship between Kt/V and URR. Due to continued production of fish waste (e.g., urea generation) during the removal process, the URR for any given Kt/V decreases as the session length increases.

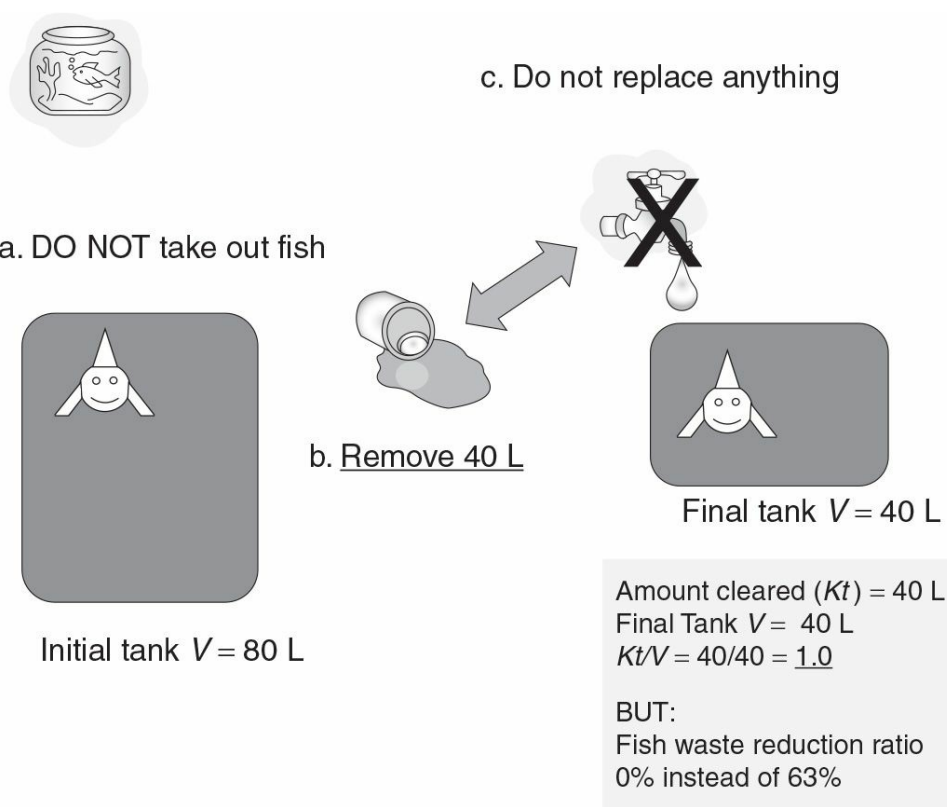

FIGURE 3.13 Effect of volume reduction on the relation between Kt/V and URR. Urea (or fish waste) removed in the process of volume contraction will not be reflected in the URR. Kt/V is calculated based on the postdialysis value for V .

6. **Quantification of the effects of urea generation and volume removal.** Figure 3.14 shows a nomogram that plots the relationship between Kt/V and URR, adjusting for urea generation and also volume removal. The dotted line is the same as the line in Figure 3.11C. Remember, a Kt/V of 1.0 was associated with a URR of 63%. With a 3.5–4.0-hour dialysis treatment, the URR will be reduced by about 0.03 due to urea generation; thus, because of urea generation, a Kt/V of 1.0 typically is reflected by a URR of around 60% (instead of 63%). The additional lines to the right and below the first solid curved line represent the relationship between URR and Kt/V when substantial fluid is removed. The heavy black line shows the relationship when 3% of body weight is removed, and the remaining two lines show the relationship when fluid removal is 6% or 9% of body weight, respectively. A 3%-weight loss (2.1 kg in a 70 kg patient) might be thought of as typical. We can read off the URR corresponding to a Kt/V of 1.2 by moving up from 1.2 on the horizontal axis to the heavy black isopleth (curved line), and then moving left to the vertical axis. The intersection of 1.2 with the 0.03 isopleth corresponds to a URR of 65%. This is why guidelines recommending a minimum Kt/V of 1.2 also recommend a URR of at least 65%. However, the relationship between Kt/V and URR is not entirely fixed. If one is removing 9% of body weight during dialysis, a URR of 65% translates to a Kt/V of 1.4, with the extra 0.2 Kt/V units coming from waste product removal that is not reflected in a concentration change. Similarly, one can achieve a Kt/V of 1.2 in patients with a 9% fluid removal rate with a URR of only 58%. Other points of interest corresponding to a URR of 75% are also shown on the graph. When URR is 75%, Kt/V will be 1.5, 1.6, 1.7, or 1.8 when fluid removal is

0%, 3%, 6%, or 9% of body weight, respectively.

EFFECT OF FLUID REMOVAL (UF/W) on URR vs. Kt/V 6% of body weight removed (4 L in 70 kg) extra 0.15 – 0.2 Kt/V

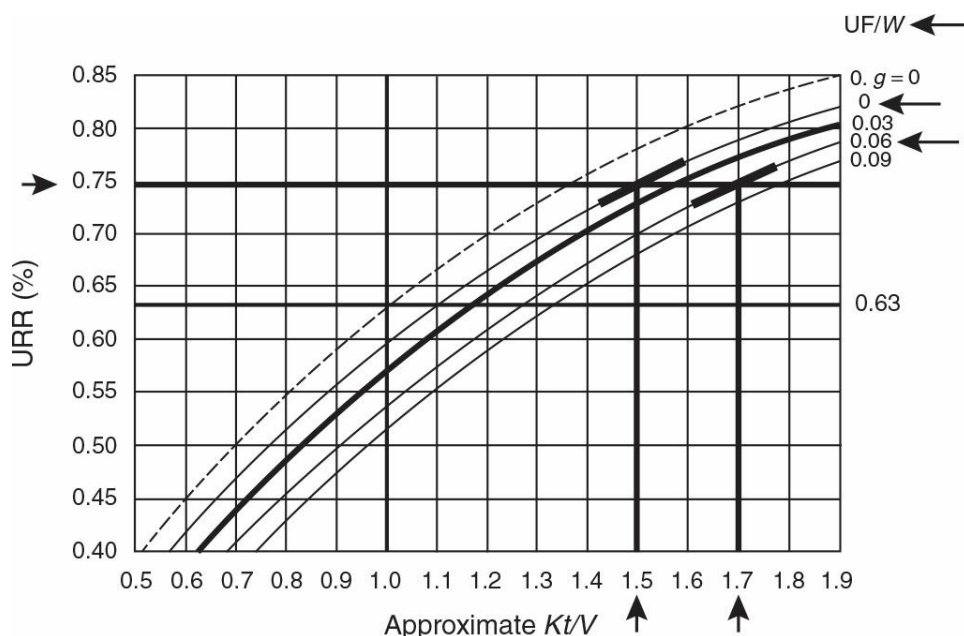

FIGURE 3.14 Actual relationship between Kt/V and URR, taking into account urea generation and the effects of volume contraction. We now see that a Kt/V of 1.0 corresponds to a URR of 0.60 instead of 0.63, due to urea generation. In fact, depending on how much fluid is removed as a percentage of the body weight, a Kt/V of 1.0 can be attained with URR values as low as 0.52, with an average URR of 0.57 (*heavy line* represents the usual UF/W of 3%). A URR of 75% can correspond to a Kt/V of 1.5 in a patient with no fluid removal, or to a Kt/V of 1.7 in a patient from whom 6% of body weight is being removed. (Reproduced from Daugirdas JT. Urea kinetic modeling. *Hypertens Dial Clin Nephrol*. Available at: <http://www.hdcn.com>.)

Equations have been developed that can approximately translate URR to Kt/V by adjusting for the session length (urea generation) and fractional volume removal. One such equation (Daugirdas, 1995) is what follows:

$$Kt/V = -\ln(R - 0.008 \times t) + (4 - 3.5 \times R) \times 0.55 UF/V$$

where \ln is the natural logarithm, R is the ratio of postdialysis to predialysis SUN, t is the session length (in hours), UF is the volume of fluid removed during dialysis (in liters), and V is the postdialysis urea distribution volume (in liters). The $0.008 \times t$ term adjusts the post-/pre-SUN ratio, R , for urea generation and is a function of session length. For nonstandard dialysis schedules or blood draw dates, the 0.008 urea generation term can be optimized further (Daugirdas, 2013). The second adjustment term accounts for added Kt/V due to reduction in postdialysis V . If V is not known, an anthropometric estimate can be used or V can be assumed to be 55% of the postdialysis weight (W). The expression then simplifies to

$$Kt/V = -\ln(R - 0.008 \times t) + (4 - 3.5 \times R) \times UF/W$$

This is the equation that was used to generate the curves in Figure 13.14. *Thus, both the URR and Kt/V are mathematically linked, and both are determined primarily from the pre- and postdialysis SUN levels. However, the Kt/V also takes into account ultrafiltration and urea generation. Neither is superior to the other as a measure of outcome.*

7. **Multipool models, urea inbound, and rebound.** The model shown in Figure 3.11 assumes that urea is contained in a single body compartment. This assumption leads to a monoexponential decline in the SUN during dialysis, as per hollow circles in Figure 3.11B, and to a minimal rebound after dialysis has been discontinued. In fact, the SUN profile during dialysis deviates from the decrease shown in Figure 3.11B, usually being lower than expected (Fig. 3.15). Immediately after stopping dialysis, SUN rebounds to levels that cannot be explained on the basis of postdialysis urea generation (Fig. 3.15). These observations suggest that urea is being sequestered somewhere during dialysis. Because urea is being removed from a smaller apparent volume during the early part of dialysis, the SUN during the initial part of dialysis falls more quickly than expected. We have designated this unexpected early fall in SUN during the early stages of a dialysis session as urea **inbound**. Toward the end of dialysis, as a concentration gradient develops between the sequestered compartment and the accessible compartment, the fall in SUN slows. After dialysis is complete, continued movement of urea from the sequestered to the accessible compartment causes the postdialysis urea **rebound** (Fig. 3.15).
 - a. **Regional blood flow model.** Urea sequestration during dialysis was initially explained as being due to difficulties in removing urea from cells. It has now been shown that urea is sequestered during dialysis in tissues, primarily muscle, that contain a high percentage of total body water, and hence urea, but receive a low percentage of the cardiac output. Because of the low ratio of blood flow through these tissues to their urea content, the transfer rate of urea from these tissues to the dialyzer by way of the central blood circulation is slow, causing urea sequestration.

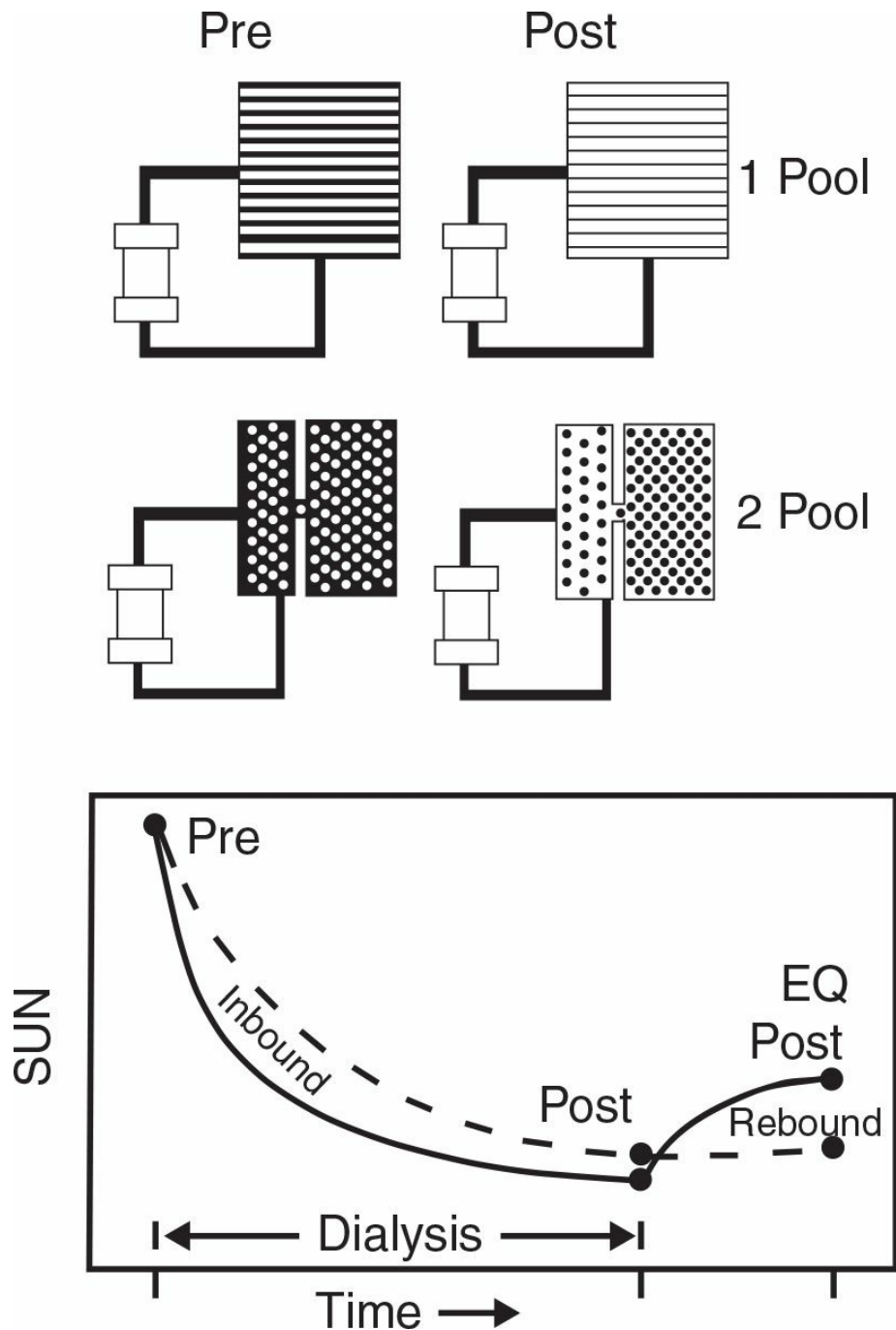

FIGURE 3.15 The effects of urea sequestration on the intradialytic fall in SUN (urea inbound) and the postdialysis increase in SUN (rebound). When there is sequestration, the intradialytic SUN level falls more quickly than expected (inbound) due to initial removal from a smaller apparent space. However, after dialysis is complete, continued entry of urea from the sequestered space to the proximal space causes urea rebound to occur. (Reproduced from Daugirdas JT. Urea kinetic modeling. *Hypertens Dial Clin Nephrol*. Available at: <http://www.hdcn.com>.)

- b. **Implications of urea inbound and rebound on measures of adequacy.** The amount of urea removed during dialysis is dependent on the time-averaged dialyzer inlet urea concentration during the treatment. If there is sequestration, the time-averaged concentration will be lower than that estimated from the pre- and postdialysis values by a single-pool model, and as a result, the single-pool model will overestimate the amount of urea removal.
- c. **The concept of equilibrated Kt/V (eKt/V).** After dialysis, urea diffuses back from

sequestered tissue sites into the blood to cause a postdialysis rebound, which is largely complete by 30–60 minutes. One can measure the postdialysis SUN at this time and compute a “true” or equilibrated URR, which will be less than the URR based on an immediate postdialysis sample. The equilibrated URR can be translated into an equilibrated Kt/V .

The amount of urea rebound depends on the intensity or rate of dialysis that was given relative to body size. The rate of dialysis can be expressed as the number of Kt/V units per hour, or (Kt/V) divided by t in hours. Based on urea modeling, a formula modified from one suggested by Tattersall (1996) can be used to predict the amount of rebound based on the rate of dialysis:

$$eKt/V = spKt/V \times Td / (Td + 30.7)$$

where eKt/V and $spKt/V$ are equilibrated and single-pool Kt/V , respectively, and Td is the dialysis session length in minutes. The 30.7 is a time constant. The constant that we recommend, 30.7 minutes, is based on data from the HEMO study (Daugirdas, 2009, 2013) and is slightly different from the value of 35 minutes originally suggested by Tattersall. Using this equation, one can calculate the eKt/V values corresponding to a $spKt/V$ of 1.2 delivered over 6, 3, or 2 hours.

$spKt/V$	t (hr)	$spKt/V$ per hour	Rebound	eKt/V
1.2	6	0.2	0.09	1.11
1.2	3	0.4	0.17	1.03
1.2	2	0.6	0.24	0.96

As is evident from the table, eKt/V can be significantly less than $spKt/V$, especially during short dialysis treatments. Perhaps for this reason, the European Best Practices guidelines set their minimum recommended dialysis Kt/V of 1.2 in terms of eKt/V rather than $spKt/V$.

IV. **ACCESS RECIRCULATION.** Normally blood flow through an AV access averages about 1 L / min. The blood pump, which normally routes a portion of this flow through the dialyzer, usually is set to take a flow of 350–500 mL/min. Because flow through the vascular access normally exceeds the demand of the blood pump, usually all of the blood coming into the blood pump is coming from the access upstream to the needle insertion site. The urea concentration of blood entering the dialyzer is the same as that in the upstream access, and there is no access recirculation (assuming, of course, that the access needles have not been placed too close to one another, and that the arterial and venous needle positions have not been inadvertently reversed). In a failing AV graft or fistula, flow through the access can decrease markedly, to 350–500 mL/min or slower. In such circumstances, part of the flow leaving the dialyzer reverses flow through the access and reenters the dialyzer. Then the dialyzer inlet blood becomes admixed, or “diluted,” with dialyzer outlet blood. This phenomenon is called *access recirculation*.

A. **Impact of access recirculation on dialysis adequacy.** When access recirculation occurs, the urea concentration in the blood entering the dialyzer may be reduced by 5%–40% or more. The amount of urea removed in the dialyzer is equal to the volume of blood cleared \times dialyzer inflow urea concentration. Although dialyzer clearance remains unchanged, the amount of urea removed is reduced because the concentration of urea entering the dialyzer inlet is reduced. In patients with access recirculation, if blood at the end of dialysis is drawn from the dialyzer inlet blood line, the urea level in this blood will be lower than that in the patient's upstream blood. Hence, the apparent postdialysis SUN will be artifactually low, and the URR and, consequently, the $spKt/V$ both will be overestimated.

B. **Avoiding the impact of access recirculation on URR or $spKt/V$ by slowing the blood flow or by stopping dialysate flow at the end of dialysis prior to blood sampling.** To ensure that blood being sampled reflects patient blood, one needs to slow the blood pump to a flow rate (e.g., 100 mL/min) that is assuredly below the access flow rate for a short period of time (10–20 seconds). Lowering the blood flow stops the backward flow of blood from the dialyzer outlet to inlet and now all blood entering the arterial needle is upstream blood. The length of the slow-flow period depends on the dead space between the tip of the arterial needle and the sampling port (usually about 9 mL in most adult blood lines). A 10–20-second period of 100 mL/min flow should be sufficient to allow the column of nonadmixed blood to reach the sampling port in most blood lines. Postdialysis blood should always be drawn after a short slow-flow period for this reason. Merely stopping the blood pump prior to drawing the sample at the end of dialysis does not prevent this problem, as the admixed blood in the inlet blood line is simply “frozen” in place. A sample taken from the inlet blood line after stopping the pump still reflects admixed blood.

Another clever method of avoiding this problem is to just shut off the dialysate flow for 3 minutes at the end of dialysis (or put dialysate flow into bypass) while letting the blood flow go full tilt. After 3 minutes, the SUN level in the blood leaving the dialyzer is similar to that going in, and so the inlet SUN level now reflects the SUN level in the patient's blood (see the 2006 National Kidney Foundation's [NKF] Kidney Disease Outcome Quality Initiative [KDOQI] adequacy guidelines).

V. **CARDIOPULMONARY RECIRCULATION.** A recirculation can be defined broadly to occur whenever blood leaving the dialyzer outlet returns to the inlet without first having traversed the peripheral urea-rich tissues. In access recirculation, the recirculation occurs via the short access segment between the venous and arterial needles. Cardiopulmonary recirculation occurs through the heart and lungs (which contain negligible amounts of urea) when the dialyzer is fed from the arterial circulation (e.g., via an AV access). During dialysis, cleared blood from the dialyzer outlet returns to the heart. In the aorta, the cleared blood is partitioned; some of it gets routed to the nonaccess arteries that lead it to the tissues to pick up more urea, but a fraction goes directly back through the access to the dialyzer without having traversed a peripheral capillary bed. When a dialyzer is fed from a venous access, cardiopulmonary recirculation cannot occur. Although an AV urea gradient is still present, all of the blood leaving the dialyzer must go through the peripheral capillary bed before it sees the dialyzer again.

A. **Impact of cardiopulmonary recirculation on dialysis adequacy.** During dialysis using either an AV or a

venous access, there is an AV gradient for urea that is established. With an AV access, the dialyzer “rides” the arterial intradialytic urea nitrogen concentration curve, which is 5%–10% lower than the venous intradialytic urea nitrogen concentration curve. Hence, dialysis with an AV access is inherently less efficient (by about 5%–10%) than that using a venous access. This effect usually is outweighed by the higher blood flow rates achievable with AV access and the avoidance of venous catheter-related access recirculation.

VI. MODELING OF UREA DISTRIBUTION VOLUME. Urea modeling can be used to determine the patient’s apparent urea space, V . This is done using the “how many marbles in the box?” method. If one removes a certain number of marbles from a box, one can determine the size of the box if one also knows the concentration change. For example, if removal of 50 marbles causes a concentration change of 50%, we know that there was originally 100 marbles in the box, and if the starting concentration is 10 marbles/L, we can calculate that the volume of the box must be 10 L. If removal of 50 marbles causes a concentration change of only 5%, we know that the starting number of marbles must have been 1,000, and with an initial concentration of 10 marbles/L, the starting volume must have been 100 L.

A urea modeling program first has to calculate how many “marbles,” that is, how much urea, was removed. The program calculates the dialyzer clearance (from dialyzer K_0A and from the blood, and dialysate flow rates), and from the session length it calculates the volume of blood cleared (Kt) during the entire dialysis session. Next, it computes a urea concentration curve during dialysis based on either a single-pool or a double-pool model, as per Figure 3.15. From this it can compute an average urea concentration during dialysis. The amount of urea removed is then simply the dialyzer clearance \times time \times average dialyzer inlet urea concentration. Next, the program knows the concentration change, because predialysis and postdialysis SUN are measured and the laboratory values are put into the program. So now the program knows how many marbles were removed plus the concentration change, and from this information it can calculate the “size of the box,” V , which is the urea distribution volume.

In general, we know that V approximates about 90% of the total body water volume. When following patients, one should always look at the modeled volume to see if it makes sense. We know that total body water is about 50%–60% of body weight. An anthropometric estimate (Watson or Hume Weyers) of V can also be used (see Appendix B). The modeled volume should be within about 25% of the anthropometric value for V .

A more powerful use of V is to follow the modeled value over time. Although values for V have a substantial variation from treatment to treatment, a large change in V may reflect an error in blood sampling technique, an unrecorded change in the amount of dialysis ($K \times t$) given, or the presence of access recirculation.

- A. **V much smaller than usual.** In this case, the URR is higher than expected, as is the Kt/V . Because the modeling program is told that K and t have not changed, the high Kt/V causes the program to conclude that the patient must have shrunk, and a smaller than usual value for V is calculated. Most often, if the V is reduced by about 100%, the problem is that the postdialysis blood sample was drawn from the dialyzer outlet line instead of the inlet.
- B. **V much larger than normal.** In this scenario, the URR and Kt/V are lower than expected, and so the program concludes that if K and t are unchanged, then the patient must have

somehow expanded to account for such a low Kt/V . In fact, the real problem is that either K or t is actually lower than recorded. The most common problems causing this are treatment interruption (full duration of dialysis session not given), lowering of the blood flow rate due to technical problems (K lower than expected), or some sort of dialyzer performance problem resulting in reduced dialyzer clearance. Access recirculation can also cause an apparent increase in V because effective clearance is reduced because of dilution of urea at the dialyzer blood inlet. One caveat: The effects of access recirculation on V will *only* be seen if blood is drawn properly (e.g., after a slow-flow period). If blood drawn postdialysis is admixed with blood from the dialyzer outlet, then the URR will be artifactually increased. The expected lowering of URR due to access recirculation then may not be seen, and modeled V may not change.

VII. UREA NITROGEN GENERATION RATE (g) AND THE nPNA. One of the benefits of urea modeling is that the generation rate of urea nitrogen (g) and the nPNA can be estimated. The way a computer modeling program does this is shown in Figure 3.16. From a pre- and postdialysis SUN and from other information regarding the dialysis session, an initial estimate of patient urea distribution volume is made, as described earlier. The program then puts in various estimates for urea nitrogen generation (g) and generates a separate sawtooth weekly SUN curve corresponding to each guess. Higher values of g will result in higher sawtooth curves. The program then looks to see which curve matches the actual measured predialysis SUN level. The level of g (and nPNA) corresponding to this curve is then chosen as the estimated value for that particular patient.

The clinical utility of g or nPNA is somewhat debatable. nPNA is not a very robust predictor of mortality (once serum albumin and creatinine are controlled for). Generally, outcome is poor when nPNA is low, as this usually reflects poor dietary intake. Before one can make the assumption that a low nPNA reflects a low dietary protein intake, one needs to make sure that other sources of urea loss such as residual renal clearance have been properly accounted for. Rarely, a patient will have a low nPNA because he or she is improving markedly, and much of the dietary protein intake is being used for anabolism; in this happy but unusual circumstance, the urea nitrogen is going into building tissue and is not “appearing” in the blood. A high nPNA is not always a good thing, as it may be due to tissue breakdown (i.e., to hypercatabolism).

How is nPNA computed in HD?

- Depends on pre-SUN
- Computer estimates patient V , then generates multiple weekly SUN profiles for different values of nPNA (g)

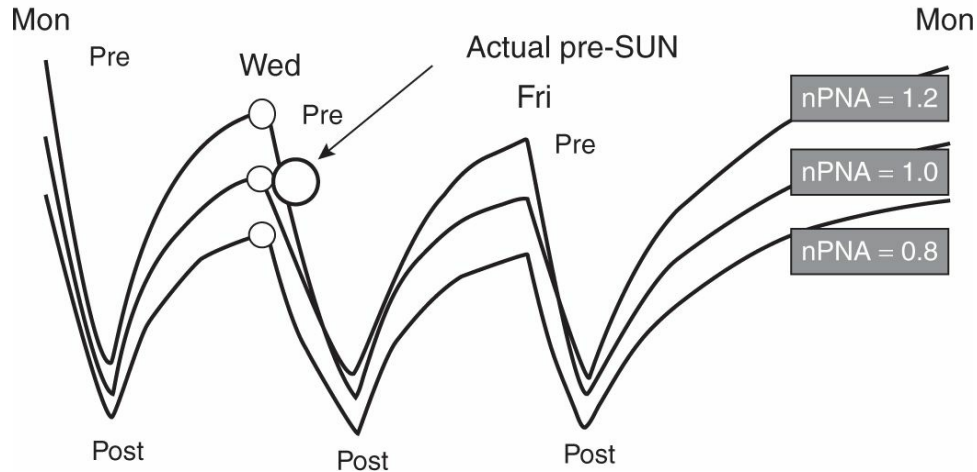

FIGURE 3.16 How a urea kinetic modeling program determines the PNA rate. From the pre- and postdialysis SUN, the session length, and volume reduction, and an estimate of dialyzer clearance, the patient V is estimated. Then various values of urea generation (which corresponds tightly to nPNA) are plugged in, and weekly sawtooth SUN patterns are generated. The nPNA is assumed to be that value that generates a curve where the sawtooth peak for the day of the week when modeling values are drawn matches the laboratory value.

VIII. RESIDUAL RENAL FUNCTION. Residual renal function has been shown to be of great survival benefit in dialysis patients, and its impact in peritoneal dialysis patients appears to be greater than that of peritoneal clearance.

In dialysis patients, residual kidney clearance can be approximated as the average of the creatinine and urea clearances. Urea clearance (K_{ru}) underestimates the glomerular filtration rate (GFR) due to proximal tubular urea reabsorption, whereas creatinine clearance (K_{rc}) overestimates GFR because of tubular secretion. It is well established that ESRD patients with substantial residual renal function (K_r) live longer, and so it is important to attempt to preserve residual function and to minimize potential injury to the end-stage kidney (e.g., by avoiding nephrotoxic drugs and by minimizing intradialytic hypotension).

A. Measuring the K_{ru} . For this, one needs to collect all urine during a 24-hour period of the interdialytic interval. Usually, the patient starts the collection 24 hours before coming to the dialysis unit and then reports to the unit with the urine container and gives a sample of blood to measure the SUN. If the patient is receiving a usual amount of dialysis (three times a week only!), and if the collection interval is 24 hours prior to dialysis, one can assume that the average serum urea level during the collection will be about 86% (prior to a midweek session) or 90% (prior to a first-of-week session) of the predialysis SUN (Daugirdas, unpublished observations). The K_{ru} calculation is then:

$$K_{ru} = \frac{UUN}{SUN} \times \text{urine flow rate (mL/min)}$$

where UUN is the urine urea nitrogen concentration.

The units for the UUN and SUN do not matter, but they must be the same, as they cancel each other out. Typically, K_{ru} values of 0–8 mL/min will be obtained.

Problem: If urine flow rate is 0.33 mL/min, or 20 mL/hr, over 24 hours one would collect 480 mL of urine. Assume that the urine urea concentration is about 800 mg/dL (285 mmol/L) and that the collection was during the 24-hour interval immediately preceding a first-of-week dialysis session. Predialysis SUN for that dialysis is 56 mg/dL (20 mmol/L). What is the K_{ru} ?

Solution in mg/dL units: First, compute the estimated mean SUN during the 24-hour collection interval. As discussed earlier, the estimated mean SUN during the collection period is 90% of the predialysis SUN, or $0.9 \times 56 = 50$ mg/dL. So $K_{ru} = (800 \text{ mg/dL} \times 0.33 \text{ mL/min}) / 50 \text{ mg/dL} = 5.3 \text{ mL/min}$.

Solution in SI units: First, compute the estimated mean SUN during the 24-hour collection interval. As discussed earlier, the estimated mean SUN during the collection period is 90% of the predialysis SUN, or $0.9 \times 20 = 18$ mmol/L. So $K_{ru} = (0.285 \text{ mmol/mL} \times 0.33 \text{ mL/min}) / 0.018 \text{ mmol/mL} = 5.3 \text{ mL/min}$.

IX. **STANDARD Kt/V UREA.** The so-called “standard” Kt/V urea grew out of two desires: (1) to come up with a measure of hemodialysis adequacy that was not dependent on number of treatments per week and (2) to have a measure where the minimum dose for hemodialysis would be similar to the minimum dose for peritoneal dialysis.

A. **Casino Lopez EKRU.** One can compute the equivalent urea clearance for any given dialysis regimen using the same principle as computing a creatinine clearance: For creatinine, if one knows the per minute generation rate (from a 24-hour urine collection) and the mean plasma level, one can compute clearance as a ratio of the two.

$$Cr_{cl} = \frac{UV}{P}$$

where Cr_{cl} is creatinine clearance, UV is the urine flow rate multiplied by the urine creatinine concentration, and P is the mean plasma concentration of creatinine during the collection period. From the timed urine collection one knows how much creatinine is being generated per minute, and if we know the plasma concentration during the collection period, we know how much plasma is being cleared to remove the amount of creatinine that is being generated to maintain steady state.

This type of calculation was adapted to hemodialysis and urea removal by Casino and Lopez (1996). As discussed earlier and as shown in Figure 3.16, a urea modeling program can obtain a value for urea generation rate for any dialysis schedule, assuming steady state. The same modeling program can then calculate the time-averaged concentration of SUN

(TAC) for the week. Once g and TAC are known, an equivalent urea clearance (EKRU) can be calculated for any dialysis regimen, similar to creatinine clearance as follows:

$$\text{EKRU} = \frac{g}{\text{TAC}}$$

If one uses this approach to calculate an EKRU corresponding to a three-times-per-week dialysis schedule with spKt/V of 1.2, the EKRU turns out to be about 11 mL/min. Theoretically, one can take any hemodialysis prescription, compute g and TAC using a modeling program, and then convert it to EKRU in mL/min. This EKRU value theoretically can be added to the measured residual renal urea clearance. The resulting EKRU can be expressed either in mL/min or in liters per week. When expressed as liters per week, EKRU can be thought of as a $(K \times t)$ term, or volume of plasma cleared during the week, and this can then be normalized to V to calculate a weekly equivalent Kt/V urea.

Problem: In a patient with $V = 35$ L, EKRU is 11 mL/min. What is the equivalent weekly Kt/V urea?

Solution: $11 \text{ mL/min} \times 10,080 \text{ min per week}$ divided by 1,000 to convert milliliters to liters gives a weekly volume of plasma cleared of 110 L per week. This is the $K \times t$ term of Kt/V . Dividing by $V = 35$, we get weekly Kt/V urea = 3.14.

- B. **Standard Kt/V urea.** One problem with the EKRU metric was that the minimum spKt/V of 1.2 given three times per week seemed to translate into a weekly equivalent Kt/V urea of 3.14, substantially higher than the weekly Kt/V urea of around 2.0 needed in peritoneal dialysis patients. To fix this problem, Keshaviah, and later Gotch, proposed a “peak concentration hypothesis.” They surmised that one difference between PD and hemodialysis is that in the latter there are peaks of urea and other uremic toxins. They also noticed that for a three-times-per-week schedule, the average peak concentration of urea was about one-third higher than the time-averaged concentration. Accordingly, they suggested dividing g by the mean weekly predialysis SUN level instead of by the time-averaged urea level (Fig. 3.17). Dividing by the higher mean predialysis value resulted in lowering the new measure of dialysis adequacy by about one-third. For a standard three-times-per-week HD regimen with a spKt/V of 1.2, the new equivalent clearance was about 7 mL/min versus 11 mL/min with EKRU, and the weekly equivalent Kt/V using the new measure, termed “standard Kt/V ” by Gotch, was 2.0, similar to that for peritoneal dialysis.

What is “standard” Kt/V ?

- Devised to make HD and PD match

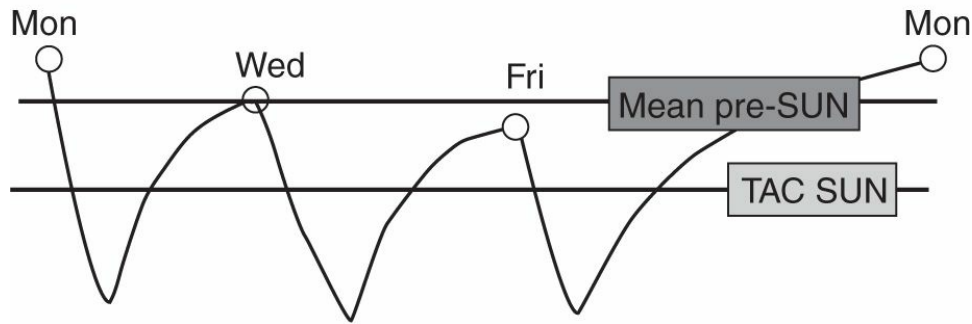

- Divide g by mean pre-SUN instead of by TAC SUN
- Resulting equivalent weekly Kt/V is about 1/3 lower

FIGURE 3.17 How standard Kt/V is calculated. The urea generation rate is determined along with the nPNA as in Figure 3.16, and then this figure is divided by the average predialysis SUN level.

1. **Sequestered solute and standard Kt/V .** It has been pointed out by Depner that standard Kt/V might be thought of as modeling a solute other than urea. The solute representing standard Kt/V would be easily removed by dialysis, but would be highly sequestered, with a very high postdialysis rebound. The mean predialysis level of such a highly sequestered solute would be similar to its time-averaged value. Removal of such a highly sequestered solute would be markedly improved by increasing dialysis frequency. If one looks at the relationship between standard Kt/V and dialysis frequency (Fig. 3.18), it is clear that standard Kt/V can only be increased above 3.0 or so if dialysis frequency is more than three times per week.
2. **Calculating the dialysis-related standard Kt/V in clinical practice.** This can be done using a urea kinetics modeling program. An open source version of a formal urea kinetic modeling program is available at <http://ureakinetics.org> (Daugirdas, 2009). Dialysis-related standard Kt/V can also be computed using a simplified equation developed by the FHN group of investigators (Daugirdas, 2010) as described in Appendix C.

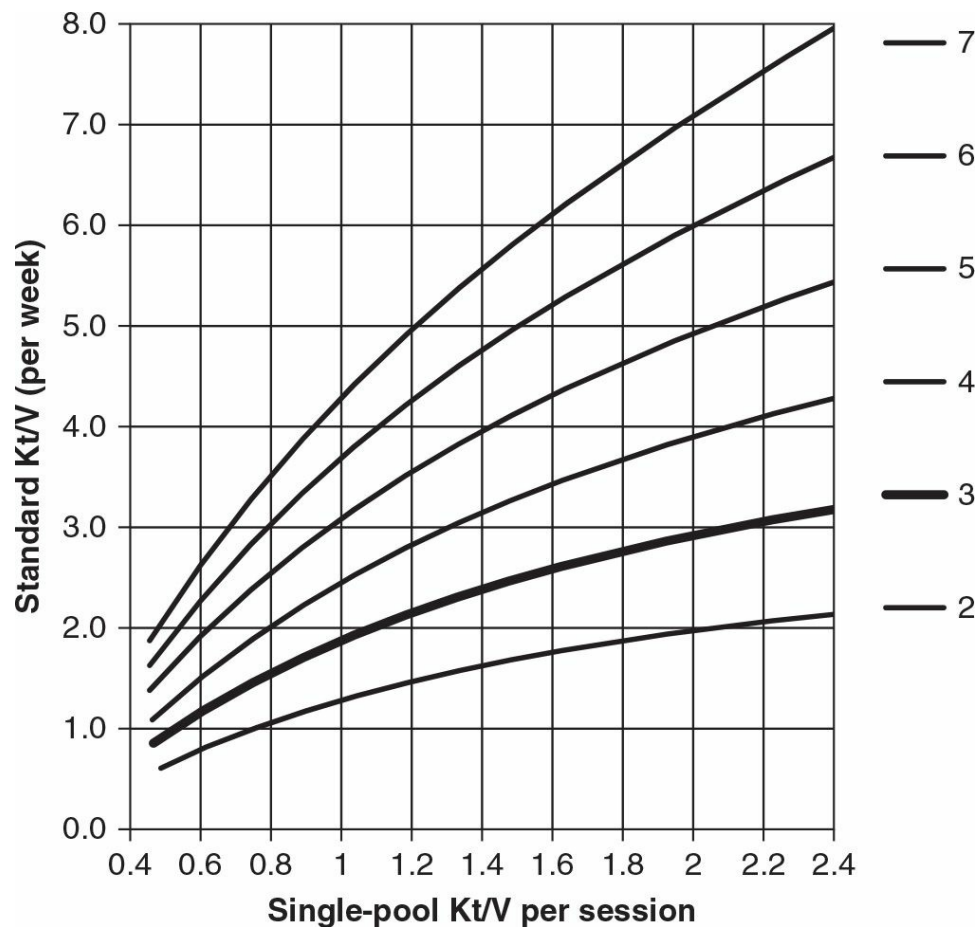

FIGURE 3.18 Standard Kt/V as a function of treatment Kt/V (single pool) and number of treatments per week (shown on the right). This is the modeled standard Kt/V , using a dialyzer clearance of 220 mL/min in a patient with a V of 40 L. As shown, it is difficult to get to a standard Kt/V greater than 3.0 with a three-times-per-week schedule. Dialysis times ranged from 30 to 450 min.

3. **Adding the residual renal urea clearance to standard Kt/V urea.** Direct addition of residual renal urea clearance to standard Kt/V is problematic, as the standard Kt/V is an artificial construct. Some people do this, some do not. One needs to calculate the dialysis component of standard Kt/V and express it as mL/min format by multiplying by V and dividing by the number of minutes in a week. Then one can add residual renal urea clearance. After the residual renal clearance has been added, one can convert back to a weekly value (Daugirdas, 2010).
- C. **Issues relating to normalizing by V .** Normalizing Kt to V is convenient and makes sense, because urea is distributed in total body water and its generation rate is proportional to V . However, because V represents largely muscle mass, it is not entirely clear that someone with 10% more muscle needs 10% more dialysis. Dosing dialysis by Kt/V may result in lower doses of dialysis for smaller people, including women and children (Daugirdas, 2014). An alternative approach is to scale the dialysis dose ($K \times t$) to body surface area. This will result in relatively more dialysis for smaller people, women and children, and relatively less dialysis for larger patients. Some observational data support use of such an alternative, body surface area scaling approach (Lowrie, 2005). These scaling issues are discussed more completely in a recent review (Daugirdas, 2014). See Appendix C for a method of calculating surface-area normalized standard Kt/V .

X. MACHINE-ESTIMATED MEASURES OF HEMODIALYSIS ADEQUACY

- A. **Estimating dialyzer clearance by pulsing dialysate with sodium and analyzing resulting changes in dialysate conductivity.** Measuring adequacy using urea is time consuming and involves the use of needles, exposure of staff and patient to blood, and considerable effort in processing and analyzing blood samples. One alternative approach is to measure the clearance of the dialyzer online by causing a step increase in dialysate sodium and then measuring the conductivity of the dialysate flowing into the dialyzer and comparing this to the dialysate exiting the dialyzer over a short period of time. Many of the technical issues have been solved, and dialyzer conductivity-based clearances reflect in vivo dialyzer urea clearances quite well. An advantage of this method is that clearances can be computed multiple times throughout a dialysis session. One disadvantage is that conductivity-based clearances measure what happens in terms of dialyzer clearance, but not what happens in the patient. See Gotch (2004) and McIntyre (2003) for a more complete discussion of these issues.
- B. **UV absorbance of spent dialysate.** Another approach to machine-measured hemodialysis adequacy is to monitor the ultraviolet (UV) light absorbance of spent dialysate. UV light absorption at selected wavelengths corresponds to dialysate concentration of uric acid, and other small-molecular-weight solutes. Analysis of the spent dialysate UV absorption curve over time mirrors what goes on in the blood, and the ratio of the early and late dialysate UV absorption mirrors the predialysis and postdialysis SUN. From this the Kt/V of a treatment can be computed as it progresses, and the information reflects what is happening in the patient (Uhlen, 2006).

References and Suggested Readings

- Casino FG, Lopez T. The equivalent renal urea clearance. A new parameter to assess dialysis dose. *Nephrol Dial Transplant*. 1996;11:1574–1581.
- Daugirdas JT. Simplified equations for monitoring Kt/V , PCRn, eKt/V , and $ePCRn$. *Adv Ren Replace Ther*. 1995;2:295–304.
- Daugirdas JT. Dialysis dosing for chronic hemodialysis: beyond Kt/V . *Semin Dial*. 2014;27:98–107.
- Daugirdas JT, Schneditz D. Overestimation of hemodialysis dose depends on dialysis efficiency by regional blood flow but not by conventional two pool urea kinetic analysis. *ASAIO J*. 1995;41:M719–M724.
- Daugirdas JT, et al; for the Hemodialysis Study Group. Factors that affect postdialysis rebound in serum urea concentration, including the rate of dialysis: results from the HEMO Study. *J Am Soc Nephrol*. 2004;15:194–203.
- Daugirdas JT, et al. Solute-solver: a Web-based tool for modeling urea kinetics for a broad range of hemodialysis schedules in multiple patients. *Am J Kidney Dis*. 2009;54:798–809.
- Daugirdas JT, et al; Frequent Hemodialysis Network Trial Group. Standard Kt/V urea: a method of calculation that includes effects of fluid removal and residual kidney clearance. *Kidney Int*. 2010;77:637–644.
- Daugirdas JT, et al; FHN Trial Group. Improved equation for estimating single-pool Kt/V at higher dialysis frequencies. *Nephrol Dial Transplant*. 2013;28:2156–2160.

- Depner TA, Daugirdas JT. Equations for normalized protein catabolic rate based on two-point modeling of hemodialysis urea kinetics. *J Am Soc Nephrol*. 1996;7:780–785.
- Depner TA, et al. Dialyzer performance in the HEMO study: in vivo K_0A and true blood flow determined from a model of cross-dialyzer urea extraction. *ASAIO J*. 2004;50:85–93.
- Gotch FA. Evolution of the single-pool urea kinetic model [abstract]. *Semin Dial*. 2001;14(4):252–256.
- Gotch FA, et al. Mechanisms determining the ratio of conductivity clearance to urea clearance. *Kidney Int Suppl*. 2004;(89):S3–S24.
- Leypoldt JK, Jaber BL, Zimmerman DL. Predicting treatment dose for novel therapies using urea standard Kt/V . *Semin Dial*. 2004;17:142–145.
- Leypoldt JK, et al. Hemodialyzer mass transfer-area coefficients for urea increase at high dialysate flow rates. The Hemodialysis (HEMO) study. *Kidney Int*. 1997;51:2013–2017.
- Lowrie EG, et al. The online measurement of hemodialysis dose (Kt): clinical outcome as a function of body surface area. *Kidney Int*. 2005;68(3):1344–1354.
- Melamed ML, et al. Retained organic solutes, patient characteristics and all-cause and cardiovascular mortality in hemodialysis: results from the retained organic solutes and clinical outcomes (ROSCO) investigators. *BMC Nephrol*. 2013;14:134.
- McIntyre CW, et al. Assessment of haemodialysis adequacy by ionic dialysance: intra-patient variability of delivered treatment. *Nephrol Dial Transplant*. 2003;18:559–563.
- Schneditz D, et al. Cardiopulmonary recirculation during dialysis. *Kidney Int*. 1992;42:1450.
- Sirich TL, et al. Numerous protein-bound solutes are cleared by the kidney with high efficiency. *Kidney Int*. 2013;84:585–590.
- Tattersall JE, et al. The post-hemodialysis rebound: predicting and quantifying its effect on Kt/V . *Kidney Int*. 1996;50:2094–2102.
- Uhlen F, et al. Dialysis dose (Kt/V) and clearance variation sensitivity using measurement of ultraviolet-absorbance (on-line), blood urea, dialysate urea and ionic dialysance. *Nephrol Dial Transplant*. 2006;21:2225–2231.

Web References

- KDOQI Hemodialysis Adequacy guidelines 2006. <http://www.kidney.org>.
- Urea kinetic modeling calculators. <http://www.ureakinetics.org>.
- Urea kinetic modeling channel. <http://www.hdcn.com/ch/adeq/>.

4

Hemodialysis Apparatus

Suhail Ahmad, Madhukar Misra,
Nicholas Hoenich, and John T.
Daugirdas

Hemodialysis (HD) apparatus can be broadly divided into a blood circuit and a dialysis solution circuit, which meet at the dialyzer. The blood circuit begins at the vascular access. From there blood is pumped through an “arterial blood line” to the dialyzer. Blood is returned from the dialyzer to the patient via a “venous blood line.” These terms are used even though often only venous blood is being accessed (such as when using a venous catheter). More precise would be to term these the “inflow” blood line and “outflow” blood line, but as often is the case, the traditional names rather than more correct terms continue to be used. Various chambers, side ports, and monitors are attached to the inflow and outflow blood lines, and are used to infuse saline or heparin, to measure pressures and to detect any entrance of air. The dialysis solution circuit includes the dialysis solution (dialysate) supply system, which makes dialysate online by mixing purified water with concentrated dialysate solutions. The final dialysate is then pumped through the dialysate compartment of the dialyzer, the latter being separated from blood compartment by a semi-permeable membrane. The dialysis solution circuit includes various monitors that make sure that the dialysis solution is at the right temperature and has a safe concentration of dissolved components. Also, a blood leak detector is present with the purpose of stopping dialysis if blood products are detected in the outflow dialysate.

I. **BLOOD CIRCUIT.** The inflow (arterial) blood line connects the vascular access to the dialyzer, and the outflow (venous) blood line runs from the dialyzer back to the vascular access. Blood is moved through the dialyzer by a pump, usually a spring-loaded roller pump. The roller moves blood through the blood tubing by completely occluding a small segment of the tubing then rolling the occluded segment forward (like milking a straw).

A. **Inflow blood line: Prepump segment.** The prepump segment is the part of the blood line which links the patient’s access to the blood pump. This segment contains a sampling port, a saline infusion line, and, on some lines, a “prepump” pressure monitor (see P1 in Fig. 4.1).

The sampling port is used to sample blood from the line and is the point from which predialysis and postdialysis blood is usually taken. The saline infusion “T” line is used to prime the dialyzer circuit, and also to rinse-back the contents of the blood compartment at the end of dialysis. Because all three of these elements (sampling port, monitor, and saline “T”) are located in the negative pressure portion of the blood line, if a connection is broken here, air can quickly enter the blood line. In the event of an incomplete connection, microbubbles can be introduced, which can get trapped in the hollow fibers of the dialyzer,

which reduces the efficiency of dialysis, and can even lead to clotting of the circuit.

It is advisable to use blood lines with a prepump pressure monitor (P1), although not all blood lines have this. The pressure monitor is linked via a small tubing attached at a right angle to the blood line. This small tubing is kept filled with air, and the other end is attached to an air chamber that communicates through a filter to a pressure transducer. Because the blood pump is demanding blood at a fairly fast rate (200–600 mL/min) and because of the resistance to flow at the “arterial” opening of the vascular access catheter or “arterial” needle, the pressure in the segment of the “arterial” line between the vascular access and the blood pump is negative (below zero), and often substantially so. How negative, is a function of the blood flow rate, the blood viscosity (which increases with hematocrit), the size of the inflow catheter lumen or needle, and whether or not the end of the arterial needle or catheter is partially obstructed by nearby tissue from the inside wall of the vascular access.

For safety, the pressure limits of the P1 monitor are set above and below the usual normal working range for the patient. This is generally performed automatically, and the range above and below the prevailing pressure is machine dependent. If the pressure goes out of range, an audible alarm will sound and the blood pump stops. For example, the prepump pressure monitor might be set to alarm if the pressure rises above -50 or falls below -200 mm Hg. On the low (-50) side, the pressure limit alarm might be triggered by a line separation (accidental disconnection of the blood tubing from the venous catheter or arterial needle). In such a case, after the line separates, the resistance to inflow will be suddenly reduced, and the negative pressure may rise above -50 mm Hg, triggering the alarm. However, this pressure alarm should never be relied upon to detect a line separation, as the pressure may remain in range, even after a line separation. For example, if there is a partial blockage in the inflow line after line separation, or if an arterial needle pulls out from the access, continued resistance to inflow by the needle may keep pressure in the set range; then the alarm may not sound, and the blood pump will keep on pumping air into the circuit. The other use for the prepump pressure alarm is on the “high” side: if there is obstruction to blood flow either by a kink in the line or by a clot at the access needle lumen, the arterial pressure may become more negative than the set limit (e.g., -250 mm Hg); then the alarm will be activated and the blood pump will stop, giving the care provider the opportunity to investigate the source of the problem.

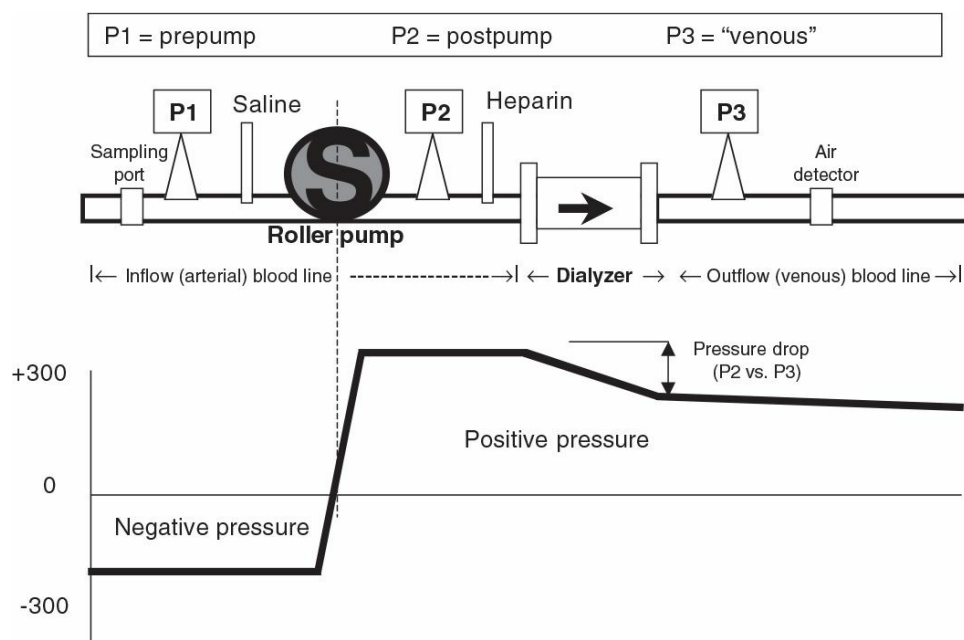

FIGURE 4.1 Pressure monitors (P1, P2, and P3) and pressures in blood circuit.

- B. **Roller pump segment.** The blood flow through the dialyzer is a function of the roller pump rotation rate and the diameter and the length of the blood line roller pump segment. In effect,

$$\text{BFR} = \frac{\text{rpm (revolutions per minute)} \times \text{roller pump segment volume } (\pi r^2 \times \text{length})}{\text{segment volume } (\pi r^2 \times \text{length})}$$

where BFR is the blood flow rate. The roller pump is generally self-occluding, that is, it adjusts to the dimension of the blood pump insert, to ensure that the full “stroke volume” is being delivered with each pass of the roller. With time, due to the repeated compression and relaxation of the pump insert with each passage of the rollers, the tubing can flatten. This reduces the “stroke volume” of the blood line and can reduce the effective blood flow rate. A similar effect may occur in the presence of a high (negative) inflow pressure. More rigid blood tubings have attempted to minimize this problem, and some machines have a built-in correction factor for the pump speed and the magnitude of negative pressure, a correction factor that one uses to correct blood flow rates.

- C. **Inflow (arterial) blood line: Postpump segment.** This contains a “T” for heparin infusion, and also, in some lines, a small “T” connected to a postpump (P2 in Fig. 4.1) pressure monitor. The pressure reading in this segment is always positive (above atmospheric). The pressure at P2 can be combined with the reading at the venous pressure monitor, P3, to estimate the average pressure in the blood compartment of the dialyzer. In some machines, this, in combination with the pressure measured in the dialysis solution compartment, is used to calculate how much ultrafiltration (UF) is taking place during dialysis. The pressure at the postpump monitor is normally quite high and depends on the blood flow rate, blood viscosity, and downstream resistance at the dialyzer and beyond. A sudden rise in the pressure at the P2 monitor is often a sign of impending clotting of the blood line and/or dialyzer. The heparin line is connected to a syringe containing heparin. The syringe is clamped into a mechanical device that slowly pushes on its plunger, delivering heparin at a

constant rate during dialysis.

- D. **Outflow (venous) blood line: Air trap and pressure monitor.** The outflow blood line contains a venous “drip chamber” that allows for the collection and easy removal of any accumulated air from the line, a so-called “venous” pressure monitor (P3 in Fig. 4.1), and an air detector. The venous pressure can be used to monitor the state of coagulation. Incipient clotting of the blood circuit will usually first take place at the venous drip chamber, and clotting will cause a progressive rise in pressures at both P3 and P2. Venous pressure during dialysis is a function of blood flow rate, blood viscosity, and downstream access (needle or catheter) resistance. In patients with AV access, trends in venous pressure from dialysis to dialysis, measured at a standard, low blood flow rate, and corrected for patient’s blood pressure, height of the drip chamber and needle size, have been used to predict the occurrence of stenosis of the downstream vascular access (see Chapter 8). During dialysis, pressure cutoff limits in this venous (P3) monitor are also set around the usual operating pressures. If there is a sudden kink in the line, the pressure measured at P3 will suddenly shoot up over the preset limit and the blood pump will cut off. A sudden line disconnection may lower the pressure at P3 below the lower alarm cutoff limit, again shutting down the machine and limiting the extent of blood loss, but this by no means occurs all the time, especially when an AV fistula is used for access (Ribitsch, 2013) although a line separation from a venous catheter also may fail to trigger a venous pressure alarm, particularly when the operating venous pressure is relatively low. Again, with an AV access, if the venous needle is inadvertently pulled out from the access, this may not change the outflow pressure much, since most of the outflow resistance is in the venous needle. It is important to note that a venous pressure alarm CANNOT be relied upon to detect a venous line separation, and patients have exsanguinated due to continued operation of the blood pump when line separation went undetected (Axley, 2012; Ribitsch, 2013). For this reason, in patients who are at a high risk for line separation, such as those with cognitive defects, agitation, or those who repeatedly thwart staff efforts to leave their access site exposed, additional devices such as the Redsense sensor (Redsense Medical, Inc., Chicago, IL) can be used to detect blood leakage at the site of potential line separation. Attention must also be paid to effective taping of access needle insertion sites and connections, and the site of the vascular access should always be exposed to caregivers’ view (Axley, 2012).

The venous air trap and detector are very important for patient safety. The chamber traps any air that may have entered the blood line before the blood is returned to the patient. Usually a level/air detector is placed around the top of the drip chamber; any increase in air (resulting in the drop of blood level) triggers an alarm. The power supply to the pump is then cut off and dialysis stops. An additional safety device is a powerful clamp below the drip chamber through which the blood tubing returning the blood to the patient passes, and which is activated by the presence of air in the blood tubing. When activated, the clamp snaps shut and blood pump is stopped; any air/blood mixture that may be present in the blood line is thereby prevented from passing back into the patient.

Despite the presence of an air detector, microbubbles can still pass to the patient. These microbubbles enter the circulation; however, their consequences are largely unknown. One

strategy to limit microbubble formation is to maintain a high fluid level in the venous air chamber. The use of dialyzers that are provided by the manufacturer with fluid already filling the hollow fibers has also been shown to limit the release of microbubbles into the circulation during dialysis (Forsberg, 2013).

Additional practical information about the interpretation and use of pressure monitors during dialysis is given in Chapter 10.

II. DIALYSIS FLUID CIRCUIT. The dialysis fluid circuit contains a number of distinct components: (a) a stand-alone water purification system, (b) a proportionating system in which concentrates and treated water are mixed and delivered to the dialyzer, (c) monitors and alarms, (d) ultrafiltration control, and (e) advanced control options.

A. Water purification system. Patients are exposed to about 120–200 L of water during each dialysis treatment. All small-molecular-weight substances present in the water can pass across the dialyzer and enter the patient's blood stream. For this reason, it is very important that the purity of the water used for dialysis be monitored and controlled. The Association for the Advancement of Medical Instrumentation (AAMI) has developed minimum standards for the purity of water used in hemodialysis. These and the methods of purifying water for dialysis are discussed in detail in Chapter 5.

B. Proportioning system. The basics of making dialysis solution are discussed in Chapter 5. Briefly, dialysis machines mix concentrated electrolyte solutions or powders with purified water to make a final dialysis solution that is delivered to the dialyzer. The final dialysis solution must be delivered at an appropriate temperature and it must be free of excessive dissolved air. This requires additional features, incorporating monitors and alarms.

Two types of proportioning systems exist: In the **central delivery system**, all of the dialysis solution used in the dialysis unit is produced by a single apparatus that mixes concentrates with purified water. The final dialysis solution is pumped through pipes to each dialysis machine. This approach offers the advantage of a lower initial equipment cost and reduced labor costs. However, it does not permit variations in the composition of dialysis solution for individual patients, and any error in the system exposes a large numbers of patients to complications arising from such errors. The second type is an **individual system**, in which each dialysis machine proportions its own dialysis solution concentrate with purified water.

C. Heating and degassing. Dialysis solution must be delivered to the dialyzer at the correct temperature (usually 35–38°C). Water obtained from a city water supply is below room temperature and must be heated; during heating, gases dissolved in the cold water expand and bubble out. The dialysis machine must remove this air from the water before use. Degassing is performed by exposing the heated water to a negative pressure.

D. Monitors and alarms. Several monitors and alarms are placed in the dialysis solution circuit to ensure safety.

1. Conductivity. If the proportioning system that dilutes the concentrates with water malfunctions, an excessively dilute or concentrated dialysis solution can be produced. Exposure of blood to a severely hyperosmolar dialysis solution can lead to hypernatremia and other electrolyte disturbances. Exposure to a severely hypoosmolar

dialysis solution can result in rapid hemolysis and severe hyponatremia and hyperkalemia. Because the primary solutes in dialysis solution are electrolytes, the degree of their concentration in dialysis solution will be reflected by its electrical conductivity. A meter that continuously monitors dialysis fluid conductivity is incorporated in all proportionating systems. Conductivity is measured in terms of milliSiemens (mS) per centimeter (cm). One Siemen (S) is equal to the reciprocal of one ohm (an alternative term for a Siemen is “mho”). The normal conductivity range for dialysis solution is 12–16 mS/cm. If conductivity falls outside the preset limits, an alarm sounds and dialysate is prevented from proceeding to the dialyzer by a valve that diverts the dialysis solution to the drain. In such an event, the system “goes into bypass” protecting the patient and dialysis stops until the problem has been resolved. Causes of dialysis solution conductivity out of range include the following:

- a. Empty concentrate container
 - b. Concentrate line connector not plugged in
 - c. Low water inlet pressure
 - d. Incorrect concentrate being used
 - e. Mixing chamber leakage
2. **Temperature.** Malfunction of the heating element in the dialysis machine can result in the production of excessively cool or hot dialysis solution. Use of cool dialysis solution (down to 35°C) is not dangerous unless the patient is unconscious, in which case hypothermia can occur. A conscious patient will complain of feeling cold and shiver. On the other hand, use of a dialysis solution heated to >42°C can lead to blood protein denaturation and, ultimately, to hemolysis. The dialysis fluid circuit contains a temperature sensor, and if the temperature is outside the acceptable limits, the dialysis fluid is diverted to drain, as discussed earlier.
 3. **Bypass valve.** As mentioned previously, if either the dialysis solution conductivity or the temperature is out of limits, a bypass valve is activated to divert the dialysis solution around the dialyzer directly to the drain.
 4. **Blood leak detector.** Small blood leaks will be invisible to the naked eye. A blood leak detector is placed in the dialysate outflow line (line containing dialysis fluid after it has passed through the dialyzer). If the detector senses blood, as occurs when a leak develops through the dialyzer membrane, the appropriate alarm is activated and the blood flow through the dialyzer is stopped automatically, to prevent potentially catastrophic blood loss.
 5. **Dialysate outflow pressure monitor.** In machines that do not have special pumps and circuitry to control the UF rate directly, the pressure at this location can be used in conjunction with the pressure at the blood outflow line to calculate the dialyzer transmembrane pressure (TMP) and thereby estimate the UF rate.
- E. **Ultrafiltration control.** With the use of high-flux/high-efficiency dialyzers it is necessary to have machines that can accurately control the UF rate throughout the treatment. There are several different methods in use and the hydraulics involved are complex and beyond the scope of this handbook. Precise UF control is a desirable feature for a dialysis machine to have and a manual approach to determine the UF rate by estimating the TMP is fraught with potential

errors.

The most advanced method of UF control is a volumetric method. Such volumetric circuitry is incorporated into many currently produced dialysis machines. With these machines, even dialyzers that are very water permeable ($K_{UF} > 10$ mL/h per mm Hg) can be used safely. Such systems have methods of tracking the dialysis solution inflow and matching it with the dialysis solution outflow either by having balancing chambers or double-gear systems. This ensures that the volume of fluid delivered to the dialyzer is equal to that removed from the dialyzer. A separate line from the dialysate outflow line goes through a UF pump, which sets the UF rate. The pump is controlled by a central microprocessor, which tracks the desired UF and the total UF and adjusts the UF pump speed accordingly. The line exiting the UF pump rejoins the dialysis solution outflow and both flows continue on to the drain.

In simpler, older dialysis machines, the amount of fluid removed is estimated based on the water permeability (K_{UF}) of the dialyzer and the pressures measured across the dialyzer membrane, using data from the pressure sensors in the blood line (P3 or the average of P2 and P3) and a pressure sensor in the dialysis solution outflow line.

F. Advanced control options

1. **Adjustable bicarbonate.** Machines using the three-stream method (i.e., acid concentrate, bicarbonate concentrate, and water) with a variable bicarbonate option can alter the proportioning of the bicarbonate concentrate. These machines allow delivery of final bicarbonate concentrations within the range of 20–40 mM, and this variable setting is useful in the treatment of acidotic patients or patients either with frank metabolic alkalemia (with high serum bicarbonate levels) or who are at high risk of developing respiratory alkalosis.

In most machines, the bicarbonate concentration showing on the display panel is estimated from the conductivity, and it does not include additional base content in the dialysate from acetate or citrate, which may be as high as 8 mM. The need to consider not only dialysis solution bicarbonate but total potential base content is discussed in greater detail in Chapter 5.

In order to aim for a stable dialysis solution sodium level, whenever the delivery rate of the bicarbonate concentrate is altered, a reciprocal change in the delivery rate of the acid concentrate occurs. As a result, minor changes in the other electrolytes such as calcium, magnesium, and potassium that are provided by the acid concentrate can take place.

2. **Variable sodium.** This option permits alteration of the dialysis solution sodium concentration by simply turning a dial. The sodium concentration is usually altered by changing the proportions of “acid concentrate” and water. Changing the dialysis solution sodium level in this manner will also slightly change the concentration of all the other solutes present in the “acid concentrate.” The variable sodium option allows for the individualization of the dialysis solution sodium concentration on a patient-by-patient basis and also allows for the sodium concentration to be changed during the dialysis procedure according to a preset profile. Use of such profiles may, however,

expose patients to a potential sodium gain during dialysis treatment, leading to thirst, hypertension, and increased fluid intake between treatments.

3. **Programmable ultrafiltration.** Normally, UF is performed at the same rate throughout the dialysis session. Some believe that a constant rate of fluid removal is not necessarily the best approach, since patients can tolerate higher UF rates earlier as opposed to later in a dialysis treatment. Some dialysis machines allow for the bulk of the UF to be performed during the initial portion of a dialysis session and also allow the operator to devise any form of UF profile desired. The clinical benefits of programmable UF have not been demonstrated by controlled studies.
4. **Monitoring UV absorbance of spent dialysate (online Kt/V).** The concentration of small molecular weight substances in the spent dialysate can be monitored over the course of a dialysis treatment by following the ultraviolet light absorbance of spent dialysate as it leaves the dialyzer. The resulting curve reflects the change in blood urea concentration during the dialysis treatment, and can be used to calculate an online Kt/V .
5. **Online sodium clearance monitors.** The monitoring of dialyzer urea clearance can also be done based on conductivity measurements. As sodium clearance is similar to urea clearance, it can be used to estimate the urea clearance of a dialyzer just prior to use and also during dialysis. In such an approach, the machine changes the concentrate to water proportioning ratio, which initiates a momentary change in the sodium concentration of the dialysis solution flowing into the dialyzer. A conductivity sensor located at the dialysis solution inflow line measures the extent of this perturbation. A second conductivity sensor located at the dialysate outflow line then evaluates to what extent this “pulse” of increased sodium was attenuated during passage of dialysate through the dialyzer. Using this information, the dialyzer in vivo sodium clearance can be calculated, and this information can be combined with the V derived from anthropometric data or bioimpedance, and with session treatment duration (t), to estimate Kt/V . Such sodium clearances can be repeated at any point in time during the treatment.
6. **Blood temperature control module.** Hemodialysis is associated with a heat gain during treatment, which, in turn, leads to vasodilation and a fall in blood pressure. By monitoring the temperature of the incoming and the exiting blood, as well as of the dialysis solution, it is possible to control heat balance and achieve an “isothermic” dialysis for increased hemodynamic stability. The module may also be used to measure access recirculation or blood flow as described below.
7. **Modules to measure access recirculation or access blood flow.** The presence of recirculation during dialysis decreases dialysis effectiveness, and generally occurs if the vascular access of the patient cannot deliver the required blood flow. Modules that permit the measurement of recirculation work on the dilution principle (Fig. 4.2). The composition of the blood leaving the dialyzer is quickly altered by (a) injecting 5 mL of isotonic or hypertonic saline, (b) acutely changing the dialyzer UF rate to promote hemoconcentration, or (c) acutely changing the dialysis solution temperature to cool the returning blood. A sensor attached to the blood inflow line is used to detect the resulting change in conductivity, hematocrit, or temperature. If there is access

recirculation, the perturbation applied to the outflow line will almost immediately be detected at the inflow line sensor, and the magnitude of the transmitted perturbation will reflect the degree of recirculation. To measure access flow, the blood lines are deliberately reversed, such that the inflow (arterial) needle is drawing blood from the access “downstream” to the outflow (venous) needle. In this manner, access recirculation is deliberately induced. The degree of recirculation is then measured as above. The degree of recirculation will be proportional to the ratio of flows in the extracorporeal circuit and access. Once the degree of recirculation has been measured, since the extracorporeal blood flow rate is known, the rate of access blood flow can be calculated (Krivitski, 1995).

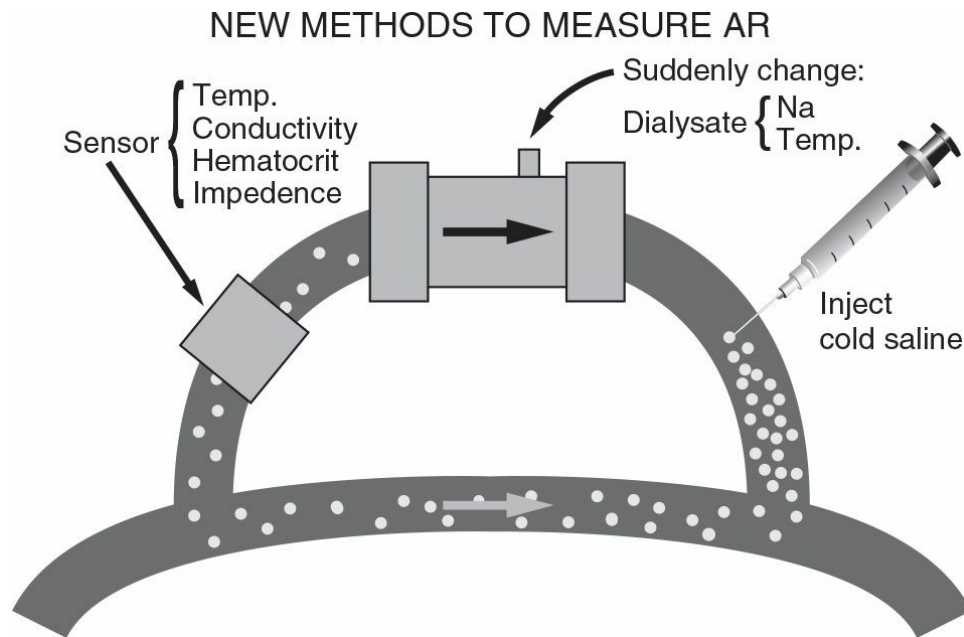

FIGURE 4.2 Principles of measuring access recirculation (AR). (Reproduced from Daugirdas JT. *Hypertens Dial Clin Nephrol*. 1997. Available at: <http://www.hdcn.com>.)

8. **Blood volume monitors.** These use an ultrasonic or optical sensor operating on the inflow blood line to detect changes in hematocrit or plasma protein concentration during dialysis. Normally, in the course of fluid removal, increases in these blood values reflect the degree of plasma volume reduction. A claimed feature of such monitors is their ability to anticipate and prevent a hypotensive episode by reducing UF whenever a steep increase in hematocrit during dialysis has occurred or when a “crash crit,” identified during previous sessions, is being approached. Another potential use is to identify patients with covert fluid overload by recognizing that such patients tend to have only a minimal, or no, increase in hematocrit during dialysis despite fluid removal.
9. **Single blood pathway (“single-needle”) devices.** Most hemodialysis treatments are performed using two separate blood pathways: one to obtain blood from the patient and another to return blood to the patient. Several systems allow dialysis to be performed using a Y-shaped single blood pathway. Description and discussion of single-needle devices are beyond the scope of this book as they are used only rarely in the United States,

however, their use is increasing in the context of home dialysis, notably, home nocturnal dialysis.

III. **THE DIALYZER.** The dialyzer is where the blood and dialysis solution circuits interact and where the movement of molecules between dialysis solution and blood across a semipermeable membrane occurs. Basically, the dialyzer shell is a box or tube with four ports. Two ports communicate with a blood compartment and two with a dialysis solution compartment. The membrane within the dialyzer separates the two compartments.

A. **Structure.** In the hollow-fiber (also called capillary) dialyzer, the blood flows into a chamber at one end of the cylindrical shell, called a *header*. From there, blood enters thousands of small capillaries tightly bound in a bundle (Fig. 4.3). The dialyzer is designed so that blood flows through the fibers and dialysis solution flows around the outside. Once through the capillaries, the blood collects in a header at the other end of the cylindrical shell and is then routed back to the patient through the venous tubing and venous access device. Historically, parallel plate dialyzers were also used, and in such devices, blood and dialysis solution pass through alternate spaces between the membrane sheets. In both configurations, blood and dialysate flows move in opposite directions, to maximize the concentration gradient between blood and dialysate in all parts of the dialyzer.

1. **Membranes.** Currently the majority of clinically used dialyzers utilize a membrane manufactured from synthetic polymer blends. Such membranes include polysulfone, polyethersulfone, polyacrylonitrile (PAN), polyamide, and polymethylmethacrylate (PMMA). It should be noted that whilst several manufacturers utilize polysulfone membranes, subtle differences exist between them, and consequently they cannot be considered as identical. Synthetic membranes are more biocompatible than the historically used membranes made from cellulose, and for this reason, as well as due to the fact that cellulose-based membranes were historically perceived to be low-flux membranes, the use of cellulose-based membranes has declined. In fact, unmodified cellulose membranes such as Cuprophan are no longer in production.

Cellulose membranes are made up of molecular chains that contain hydroxyl (OH) groups. These hydroxyl groups were largely responsible for the membranes' poor biocompatibility. Numerous attempts have been made to improve biocompatibility by chemically replacing the hydroxyl groups with acetate. Such membranes are known by their chemical name: cellulose acetate, cellulose diacetate, and cellulose triacetate depending on the number of the OH groups that were replaced in the cellulose molecule. Such membranes continue to be used clinically. Another approach has been the addition of a tertiary amino compound to liquefied cellulose during formation of the membrane. As a result, the surface of the membrane is altered, and biocompatibility is increased.

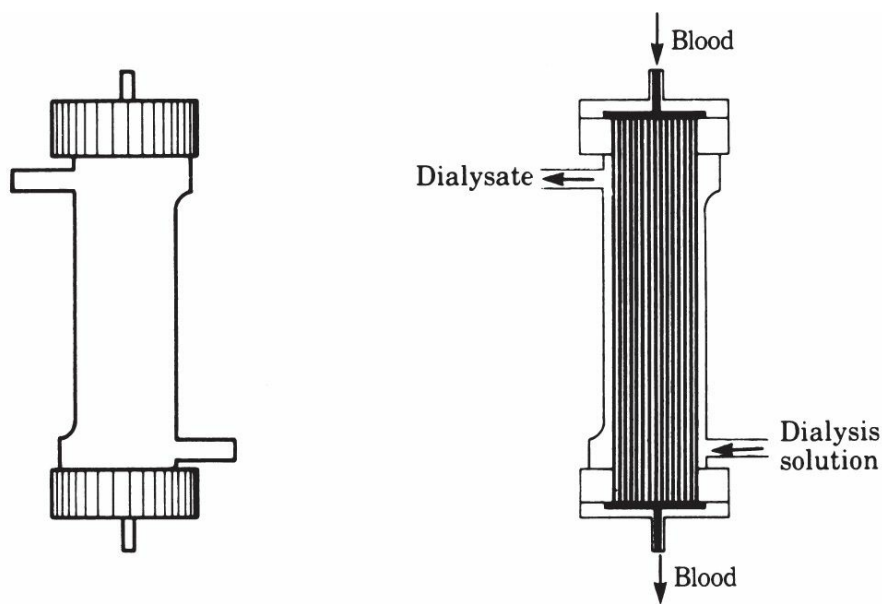

Hollow-fiber dialyzer

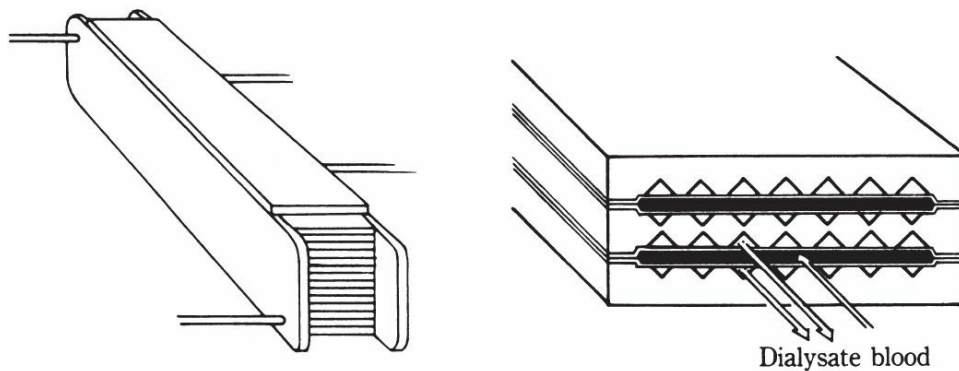

Parallel-plate dialyzer

FIGURE 4.3 Blood and dialysis solution flow pathways through a hollow-fiber and parallel-plate dialyzer. (Modified from Man NK, Jungers P. Hemodialysis equipment. In: Hamburger J, Crosnier J, Grunfeld JP, eds. *Nephrology*. New York, NY: Wiley; 1979:1206, 1207.)

2. **Coated membranes.** Improved biocompatibility has also resulted from the coating of the membrane with an antioxidant such as vitamin E. The clinical use of such membranes has resulted in an improved antioxidant profile in the blood of patients using the device, and in some studies, reduced heparin requirements and reduced clotting.
3. **Protein-losing membranes.** Because some uremic toxins are tightly bound to albumin, one school of thought has been to use membranes with a high albumin permeability deliberately. Albumin is lost during dialysis with the use of such membranes, but along with the albumin, protein-bound toxins would also be removed from the body. The clinical utilization of such membranes in routine dialysis treatment is not widespread. Very-high-molecular-weight cutoff membranes allow free passage of large macromolecules but still substantially restrict the passage of albumin. Such have been used in the treatment of patients with light chain deposition disease requiring dialysis for the removal of free light chains from the blood.

4. **Membrane permeability to solutes and to water.** The permeability to solutes and water of each class of dialyzer membranes can be altered markedly by adjusting the manufacturing process, changing the polymer ratio (which influences the membrane pore size distribution), or by adjusting the membrane thickness.
5. **Membrane efficiency versus flux.** The ability of a dialyzer to remove small-molecular-weight solutes, such as urea, is primarily a function of its membrane surface area multiplied by the permeability of the membrane to urea. A high-efficiency dialyzer is basically a big dialyzer that by virtue of its larger surface area has a high ability to remove urea. High-efficiency dialyzers can have small or large pores, and thus can have either high or low clearance for larger-molecular-weight solutes, such as β_2 -microglobulin (MW 11,800). High-flux membranes have large pores that are capable of allowing larger molecules, such as β_2 -microglobulin to pass through. Usually, β_2 -microglobulin clearances are not reported in standard dialyzer specification charts. High-flux membranes also have high water permeability, with coefficient of UF (K_{UF}) values >10 mL/h per mm Hg, and usually >20 mL/h per mm Hg.

B. **Interpreting a dialyzer specification sheet.** Information usually provided about dialyzers includes K_{UF} (UF coefficient) clearance of solutes such as urea, creatinine, vitamin B₁₂, and phosphate (and occasionally β_2 -microglobulin); membrane surface area; priming volume; fiber length; and fiber wall thickness (Table 4.1).

1. **K_{UF} .** The UF coefficient, as defined in Chapter 3, is the volume of plasma water filtered in milliliters per hour for each mm Hg of TMP. Dialyzer membranes can be classified into low-flux or high-flux varieties in accordance with their K_{UF} and large-molecule clearance. There is no universal classification, but broadly speaking, dialyzers with $K_{UF} < 8$ mL/h per mm Hg can be regarded as low-flux, whereas those with K_{UF} greater than 20 mL/h per mm Hg be regarded high-flux. Dialyzers having a K_{UF} between 8 and 20 mL/h per mm Hg are in an intermediate zone; those in the higher part of this range may be regarded as high-flux dialyzers because of their ability to pass β_2 -microglobulin.

For a dialyzer with a K_{UF} of 2.0, in order to remove 1,000 mL/h, 500 mm Hg TMP will be needed. On the other hand, if the K_{UF} is 8.0, the TMP will have to be only 125 mm Hg. When the K_{UF} is high, small errors in setting the TMP will result in large errors in the amount of ultrafiltrate removed. For this reason, dialyzers with a $K_{UF} > 6.0$ (certainly those with a $K_{UF} > 8.0$) should only be used with dialysis machines that permit accurate UF control.

The K_{UF} values reported by manufacturers on dialyzer specification sheets are usually in vitro values. In practice, the in vivo K_{UF} is often somewhat lower (5%–30%). Some companies publish both an in vitro K_{UF} and an “expected in vivo K_{UF} values. The numbers listed in Table 4.1 are mostly in vitro values.

2. **Clearance.** Similar to the native kidney, the solute removal efficiency can be expressed in terms of clearance. It can be defined as the volume of blood (plasma) from which a

solute is removed per unit time during its transit through the dialyzer. Clearance can be expressed as:

$$K_s = Q_B \frac{(C_{bi} - C_{bo})}{C_{bi}}$$

where K_s = clearance of solute s , C_{bi} = blood concentration of s at dialyzer inlet (arterial), C_{bo} = blood concentration of s at dialyzer outlet (venous), and Q_B = blood flow rate.

- a. **Mass transfer area coefficient (K_0A).** The K_0A is the maximum theoretical clearance of the dialyzer in milliliters per minute for a given solute at infinite blood and dialysis solution flow rates. For any given membrane, K_0A will be proportional to the surface area of the membrane in the dialyzer, although there is a drop-off in the gain in K_0A as membrane surface area becomes very large. The dialyzer mass transfer area coefficient for urea, K_0A , is a measure of dialyzer efficiency in clearing urea and other solutes of similar molecular weight.

Dialyzers with K_0A_{urea} values <500 should only be used for “low-efficiency” dialysis or for small patients. Dialyzers with K_0A values of 500–800 represent moderate-efficiency dialyzers, useful for routine therapy. Dialyzers with K_0A values >800 are used for “high-efficiency” dialysis, although this is a relative term; many modern dialyzers used routinely today have in vitro K_0A values of 1,200–1,600 mL/min.

1. **Urea clearance.** The clearance values provided by dialyzer manufacturers for urea (MW 60) are those measured in vitro. Clearances are usually reported at “blood” flow rates of 200, 300, and 400 mL/min. The values in the specification sheet for urea clearance are usually higher than those obtained during actual dialysis but are useful for comparing dialyzers.
- b. **Creatinine clearance.** Some manufacturers provide creatinine (MW 113) clearance values. The dialyzer creatinine clearance is usually about 80% of the urea clearance and provides no clinically useful additional information, as the clearances for the two molecules are almost always proportional, regardless of membrane or dialyzer type.
- c. **Phosphate clearance.** Because of the growing interest in prevention of hyperphosphatemia to improve outcome, some dialyzer manufacturers have begun to optimize the phosphate clearance of their dialyzers. This is often reported on dialyzer specification sheets. The main barrier to phosphate removal is the rather quick fall in serum phosphorus level that occurs early during dialysis. Because of this, only modest improvements in phosphorus removal with optimized membranes are to be expected, but the improvement is not negligible.
- d. **Vitamin B₁₂ and β_2 -microglobulin clearance.** In vitro clearance of vitamin B₁₂ (MW 1,355) is an indication of how well a membrane allows the passage of larger-molecular-weight solutes. Recently, it has become customary to consider the

clearance of β_2 -microglobulin (MW 11,800) rather than that of vitamin B₁₂ to characterize the flux of a dialyzer, as both “low-flux” and “high-flux” dialyzers will pass vitamin B₁₂. In vitro measures of β_2 -microglobulin clearance are problematic and are not reported. One problem with making dialyzers very permeable in order to increase β_2 -microglobulin removal has been increased loss of albumin. It turns out that much of this problem is due to the nonuniformity of pore size in such membranes. New “nanotechnology” approaches to manufacturing high-flux membranes have resulted in relatively high β_2 -microglobulin removal rates with very acceptable (low) levels of albumin loss.

3. **Surface area.** The membrane surface area of most dialyzers suitable for the treatment of adult patients ranges between 0.8 and 2.5 m². Smaller-size dialyzers are available from many manufacturers for the use of pediatric patients. Large surface area dialyzers normally have high urea clearances, although dialyzer design and thickness of the membrane are also important properties. Historically, the surface area played a role in respect of biocompatibility, particularly with dialyzers using membranes made of unsubstituted cellulose. This aspect of dialyzer function is less important in current dialyzers that predominantly use synthetic membranes.
4. **Priming volume.** The priming volume of most dialyzers is usually within the range of 60–120 mL and is related to the membrane surface area. It should be remembered that the priming volume of the blood lines is about 100–150 mL. Hence, total extracorporeal circuit volume will be 160–270 mL. The value of the extracorporeal volume of the blood tubing sets and dialyzer is an important consideration when treating pediatric or very small adult patients.

TABLE

4.1

Specifications of Selected Dialyzers and Hemofilters

Manufacturer	Model	Surface Area (m ²)	Membrane	Sterilization	Performance					
					K _{0t} (mL/h per mm Hg)	Urea CI Q ₀ = 200 mL/min	Urea CI Q ₀ = 300 mL/min	K _{0A} (mL/min)	Priming Volume (mL)	
ASAHI	PAN	65DX	1.3	Polycrylonitrile	ETO	29.0	181	231	635	100
		85DX	1.7	Polycrylonitrile	ETO	38.0	190	251	839	124
		110DX	2.2	Polycrylonitrile	ETO	49.0	193	260	955	161
	APS	550S	1.1	Polysulfone	Gamma	50.0	180	226	619	66
		650S	1.3	Polysulfone	Gamma	57.0	186	240	731	80
		900S	1.8	Polysulfone	Gamma	68.0	192	258	911	105
		1050S	2.1	Polysulfone	Gamma	75.0	193	261	955	114
		15R	1.5	Polysulfone	Gamma	63.0	196		1,138	82
	Rexeed	18R	1.8	Polysulfone	Gamma	71.0	198		1,367	95
		21R	2.1	Polysulfone	Gamma	74.0	199		1,597	112
		25R	2.5	Polysulfone	Gamma	80.0	199		1,597	128
		25S	2.5	Polysulfone	Gamma	80.0	199		1,597	128
		ViE	13	1.3	Polysulfone-vitamin E	Gamma	37.0	183		670
	15		1.5	Polysulfone-vitamin E	Gamma	40.0	187		755	90
	18		1.8	Polysulfone-vitamin E	Gamma	43.0	190		839	105
21	2.1		Polysulfone-vitamin E	Gamma	45.0	192		911	114	
BBraunAvitum AG	Diacap	LOPS 10	1.0	Polysulfone	Gamma	6.8	176	217	562	58
		LOPS 10	1.2	Polysulfone	Gamma	7.9	183	233	670	68
		LOPS 10	1.5	Polysulfone	Gamma	9.8	189	240	809	90
		LOPS 10	1.8	Polysulfone	Gamma	12.3	192	253	911	104

		LOPS 10	2.0	Polysulfone	Gamma	13.7	194	258	1,005	113	
		HIPS 10	1.0	Polysulfone	Gamma	34.0	180	223	619	58	
		HIPS 12	1.2	Polysulfone	Gamma	42.0	186	238	731	68	
		HIPS 15	1.5	Polysulfone	Gamma	50.0	190	245	839	90	
		HIPS 18	1.8	Polysulfone	Gamma	55.0	192	250	911	110	
		HIPS 20	2.0	Polysulfone	Gamma	58.0	194	253	1,005	121	
	xevonta	Lo 10	1.0	Polysulfone	Gamma	8.0	184	236	680	61	
		Lo 12	1.2	Polysulfone	Gamma	9.0	189	249	812	74	
		Lo 15	1.5	Polysulfone	Gamma	10.0	194	267	1,083	97	
		Lo 18	1.8	Polysulfone	Gamma	12.0	196	276	1,292	110	
		Lo 20	2.0	Polysulfone	Gamma	14.0	198	281	1,450	125	
		Lo 23	2.3	Polysulfone	Gamma	15.0	199	285	1,614	141	
		Hi 10	1.0	Polysulfone	Gamma	58.0	186	241	847	61	
		Hi 12	1.2	Polysulfone	Gamma	69.0	191	255	1,003	74	
		Hi 15	1.5	Polysulfone	Gamma	87.0	197	272	1,312	97	
		Hi 18	1.8	Polysulfone	Gamma	99.0	198	281	1,536	110	
	BAXTER	PSN	Hi 20	2.0	Polysulfone	Gamma	111.0	199	287	1,725	125
			120	1.2	Polysynthane	ETO	6.7	180	228	619	75
			140	1.4	Polysynthane	ETO	7.6	184	237	689	84
	CA	110	1.1	Cellulose acetate	ETO or Gamma	5.3	176	215	562	74	
		130	1.3	Cellulose acetate	ETO or Gamma	5.6	179	229	604	85	
		150	1.5	Cellulose acetate	ETO or Gamma	7.2	185	238	709	98	
		170	1.7	Cellulose acetate	ETO or Gamma	7.6	194	247	1,005	110	
		190	1.9	Cellulose acetate	ETO or Gamma	10.1	198		1,367	133	
	CA-HP	90	0.9	Cellulose diacetate	ETO	7.3	172	213	515	60	
		110	1.1	Cellulose diacetate	ETO	7.7	177	227	575	70	
		130	1.3	Cellulose diacetate	ETO	9.1	186	240	731	80	
		150	1.5	Cellulose diacetate	ETO	10.2	187	245	755	95	
		170	1.7	Cellulose diacetate	ETO	10.0	192	259	911	105	
		210	2.1	Cellulose diacetate	ETO	13.2	194	266	1,005	125	
	DICEA	90G	0.8	Cellulose diacetate	ETO or Gamma	6.8	173	214	526	60	
		110G	1.1	Cellulose diacetate	ETO or Gamma	8.4	179	229	604	70	
		130G	1.3	Cellulose diacetate	ETO or Gamma	10.0	186	239	731	80	
		150G	1.5	Cellulose diacetate	ETO or Gamma	11.4	189	248	809	95	
		170G	1.7	Cellulose diacetate	ETO or Gamma	12.5	191	260	873	105	
		210G	2.1	Cellulose diacetate	ETO or Gamma	15.5	196	268	1,138	125	
	TRICEA	110G	1.1	Cellulose triacetate	Gamma	25.0	188	259	781	65	
		150G	1.5	Cellulose triacetate	Gamma	29.0	197	278	1,233	90	
	EXELTRA	190G	1.9	Cellulose triacetate	Gamma	37.0	198	284	1,367	115	
		210G	2.1	Cellulose triacetate	Gamma	39.0	199	287	1,597	125	
		150	1.5	Cellulose triacetate	Gamma	31.0	193	262	955	95	
		170	1.7	Cellulose triacetate	Gamma	34.0	196	268	1,138	105	
		190	1.9	Cellulose triacetate	Gamma	36.0	197	273	1,233	115	
		210Plus	2.1	Cellulose triacetate	Gamma	47.0	199		1,597	125	
		SYNTRA	120	1.2	Polyethersulfone	Gamma	58.0	185	238	709	87
			160	1.6	Polyethersulfone	Gamma	73.0	190	253	839	117
		BELLCO-SORIN	BLS	512	1.3	Polyethersulfone	Gamma or Heat	10.0	226	599	77
				514	1.4	Polyethersulfone	Gamma or Heat	12.0	229	621	85
			517	1.7	Polyethersulfone	Gamma or Heat	17.0	234	662	99	
			812	1.2	Polyethersulfone	Gamma or Heat	51.0	241	726	73	
			814	1.4	Polyethersulfone	Gamma or Heat	61.0	246	778	85	
			816	1.6	Polyethersulfone	Gamma or Heat	68.0	250	824	94	
			819	1.9	Polyethersulfone	Gamma or Heat	80.0	255	888	109	
	FRESENIUS		F	4HPS	0.8	Polysulfone	Steam	8.0	170	190	494
		5HPS		1.0	Polysulfone	Steam	10.0	179	217	604	63
		6HPS		1.3	Polysulfone	Steam	13.0	186	237	731	78
		7HPS		1.6	Polysulfone	Steam	16.0	188	240	781	96
		8HPS		1.8	Polysulfone	Steam	18.0		252	849	113
		10HPS		2.1	Polysulfone	Steam	21.0		259	945	132
		Optiflux F		160NR	1.5	Polysulfone	e-Beam	45.0		266	1,064
			180A	1.8	Polysulfone	e-Beam	55.0		274	1,239	105
			200A	2.0	Polysulfone	e-Beam	56.0		277	1,321	113
			200NR	2.0	Polysulfone	e-Beam	56.0		277	1,321	113
			250NR	2.5	Polysulfone	e-Beam	107	198	286	1,662	135
		F	50S	1.0	Polysulfone	Steam	30.0	178		589	63
			60S	1.3	Polysulfone	Steam	40.0	185		709	82
			70S	1.6	Polysulfone	Steam	50.0	190		839	98
	FX	40	0.6	Polysulfone	Steam	20.0	170		494	32	
		50	1.0	Polysulfone	Steam	33.0	189		809	53	
		60	1.4	Polysulfone	Steam	46.0	193		955	74	
		80	1.8	Polysulfone	Steam	59.0		276	1,292	95	
	GAMBRO	Polyflux	100	2.2	Polysulfone	Steam	73.0		278	1,351	116
			14S	1.4	Polyamide blend	Steam	62.0	186	242	731	102
			17S	1.7	Polyamide blend	Steam	71.0	191	254	873	121
			21S	2.1	Polyamide blend	Steam	83.0		267	1,083	152
			24S	2.4	Polyamide blend	Steam	60.0		274	1,239	165
			140H	1.4	Polyamide blend	Steam	52.0	193	261	955	75
			170H	1.7	Polyamide blend	Steam	65.0	195	268	1,065	94
			210H	2.1	Polyamide blend	Steam	78.0		282	1,487	120
			17R	1.7	Polyamide blend	Steam	71.0		254	874	121
			21R	2.1	Polyamide blend	Steam	83.0		267	1,083	152

		24R	2.4	Polyamide blend	Steam	77.0		274	1,239	165
		14L	1.4	Polyamide blend	Steam	10.0		252	849	81
		17L	1.7	Polyamide blend	Steam	12.5		264	1,027	104
		21L	2.1	Polyamide blend	Steam	15.0		275	1,265	123
		6L/6LR	1.4	Polyamide blend	Steam	8.6		242	736	115
		8L/8LR	1.7	Polyamide blend	Steam	11.3		253	861	125
		10L/10LR	2.1	Polyamide blend	Steam	14.0		263	1,010	156
HOSPAL	Nephral	200	1.1	Polyacrylonitrile	Gamma	33.0	173	216	526	64
	ST									
		300	1.3	Polyacrylonitrile	Gamma	40.0	181	231	635	81
		400	1.7	Polyacrylonitrile	Gamma	50.0	189	250	809	98
		500	2.2	Polyacrylonitrile	Gamma	65	195		1,065	126
IDEMSA	MHP	120	1.2	Polyethersulfone	Gamma	29.0	180	220	619	71
		140	1.4	Polyethersulfone	Gamma	33.0	182	224	652	81
		160	1.6	Polyethersulfone	Gamma	37.0	186	233	731	88
		180	1.8	Polyethersulfone	Gamma	44.0	193	245	955	104
		200	2.0	Polyethersulfone	Gamma	50.0	195	251	1,065	112
NIPRO ^a	Surelyzer	110DH	1.1	Polyethersulfone	Gamma	32	187		755	68
	PES									
		150DH	1.5	Polyethersulfone	Gamma	43	195	249	1,065	93
		190DH	1.9	Polyethersulfone	Gamma	55	198		1,367	118
	Sureflux	150L	1.5	Cellulose triacetate	Gamma	12.8		249	812	90
		150E	1.5	Cellulose triacetate	Gamma	20.5		250	824	90
	FB	150U	1.5	Cellulose triacetate	Gamma	29.8		263	1,010	90
		150UH	1.5	Cellulose triacetate	Gamma	50.1		270	1,145	90
	Surelyzer	150DL	1.5	Polyethersulfone	Gamma	16		231	637	90
	PES									
NIKKISO	FLX	15GW	1.5	Polyester polymer alloy	Gamma	39	193		955	92
		18GW	1.8	Polyester polymer alloy	Gamma	47	197		1,233	108
	FDX	150GW	1.5	Polyester polymer alloy	Gamma	50	190		839	91
		180GW	1.8	Polyester polymer alloy	Gamma	57	192		911	108
	FDY	150GW	1.5	Polyester polymer alloy	Gamma	52	191		873	91
		180GW	1.8	Polyester polymer alloy	Gamma	59	193		955	108
NEPHROS	OLpur MD	190	1.9	Polyethersulfone	E-beam	90	283 ^b		1,527	140
		220	2.2	Polyethersulfone	E-beam	105	291 ^b		1,976	155
TORAY	B1-H		1.0	PMMA	Gamma	9	169		484	73
			1.3	PMMA	Gamma	12	180		619	86
			1.6	PMMA	Gamma	14	187		755	98
	B3		1.0	PMMA	Gamma	7	175		550	61
			1.3	PMMA	Gamma	8.8	184		689	76
			1.6	PMMA	Gamma	8.7	188		781	95
			2.0	PMMA	Gamma	11	193		955	118
	BK-P		1.3	PMMA	Gamma	26	182		652	76
			1.6	PMMA	Gamma	33	189		809	94
			2.1	PMMA	Gamma	41	194		1,005	126
	BS		1.3	Polysulfone	Gamma	47	192		911	81
			1.6	Polysulfone	Gamma	50.0	194		1,005	102
			1.8	Polysulfone	Gamma	52.0	197		1,233	116

Note: Apart from those made of cellulose material in the form of polysulfone and of various acetate salts of cellulose, all of the above filters are fashioned from synthetic material. All the filters above listed consist of hollow fibers. ^cCl/K_A data are at Q_f of 10 mL/min. ^dCl/K_A data at Q_f = 200 mL/min. Cl, clearance; E-beam, electron-beam; ETO, ethylene oxide; Gamma, gamma irradiation; HD, hemodialysis; HDF, hemodiafiltration; HF, hemofiltration; K_u/K_A mass transfer area coefficient for urea; K_{uf}, ultrafiltration coefficient; PMMA, polymethylmethacrylate; Q_b, blood flow rate; Q_s, substitution fluid administration rate.

- Fiber length and thickness.** This information is of little clinical usefulness. Both parameters influence flow through the fiber bundle, which, in turn, impacts on dialyzer efficiency.
- Mode of sterilization.** The four primary methods of sterilization are electron-beam, γ -irradiation, steam autoclaving, or ethylene oxide gas. The use of ethylene oxide has lost popularity because of (a) the rare but serious occurrence of anaphylactic reactions during dialysis in occasional patients who are allergic to ethylene oxide and (b) environmental concerns.

References and Suggested Readings

- Axley B, et al. Venous needle dislodgement in patients on hemodialysis. *Nephrol Nursing J.* 2012;39:435–444.
- Core Curriculum for the Dialysis Technician 5th Edition.* Medical Education Institute, Madison, WI, 2013.
- Forsberg U, et al. A high blood level in the venous chamber and a wet-stored dialyzer help to reduce exposure for microemboli during hemodialysis. *Hemodial Int.* 2013;17:612–617.
- Krivitski NM. Theory and validation of access flow measurement by dilution technique during hemodialysis. *Kidney Int.* 1995;48:244–250.
- Misra M. Core curriculum: The basics of hemodialysis equipment. *Hemodial Int.* 2005;9:30–36.
- Ribitsch W, et al. Prevalence of detectable venous pressure drops expected with venous needle dislodgement. *Semin Dial.* 2014;28:in press.
- VA Patient Safety Advisory. *Bleeding Episodes During Hemodialysis.* AD09-02. U.S. Veterans Administration Warning System. October 21, 2008. <http://www.patientsafety.va.gov/docs/alerts/BleedingEpisodesDuringDialysisAD09-02.pdf>. Accessed March 27, 2014.

Web Reference

Dialyzer K_0A calculator. <http://www.hdcn.com/calc.htm>.

- I. **PRODUCT WATER FOR HEMODIALYSIS.** Patients are exposed to 120–200 L of dialysis solution during each dialysis treatment. Any small molecular weight contaminants in the dialysis solution can enter the blood unimpeded and accumulate in the body in the absence of renal excretion. Therefore, the chemical and microbiologic purity of dialysis solution is important if patient injury is to be avoided. Dialysis solution is prepared from purified water (product water) and concentrates, the latter containing the electrolytes necessary to provide dialysis solution of the prescribed composition. Most concentrates are obtained from commercial sources and their purity is subject to regulatory oversight. The purity of the water used to prepare dialysis solution or to reconstitute concentrates from powder at a dialysis facility, is the responsibility of the dialysis facility.
- A. **Water contaminants harmful to dialysis patients.** Some substances added to municipal water supplies for public health reasons pose no threat to healthy individuals at the concentrations used, but can cause injury to renal failure patients if these substances are allowed to remain in the water used for dialysis. Therefore, all municipal water supplies should be assumed to contain substances harmful to dialysis patients, and all dialysis facilities require a system for purifying municipal water before it is used to prepare dialysis solution. What follows is a short list of the most common offending substances. Please refer to Suggested Readings for a more complete discussion of these and other contaminants.
1. **Aluminum.** This is added to water as a flocculating agent by many municipal water suppliers (aluminum sulfate is used to remove nonfilterable suspended particles). Aluminum causes bone disease, a progressive and often fatal neurologic deterioration known as the dialysis encephalopathy syndrome, and anemia.
 2. **Chloramine.** This is added to water to prevent bacterial proliferation. Chloramine causes hemolytic anemia.
 3. **Fluoride.** This is added to water supplies to reduce tooth decay. Large amounts of fluoride can elute into water from an exhausted deionizer and cause severe pruritus, nausea, and fatal ventricular fibrillation.
 4. **Copper and zinc.** These can leach from metal pipes and fittings and cause hemolytic anemia. Lead and aluminum can enter the water stream in a similar fashion.
 5. **Bacteria and endotoxin.** The water used to prepare dialysis solution and the final dialysis

solution are both susceptible to microbiologic contamination by bacteria and their endotoxins. Endotoxins, endotoxin fragments, and other bacterial products, such as short bacterial DNA fragments, some of which can be as small as 1,250 Da, can cross dialyzer membranes and enter the bloodstream to produce pyrogenic reactions and other untoward effects. The substances added to municipal water to suppress bacterial proliferation are removed by a dialysis facility's water purification system, increasing the importance of preventing bacterial growth in the purified water.

6. **Toxins from blue-green algae.** Contamination of municipal water supplies by other microbial products, such as microcystins derived from blue-green algae, can also prove toxic to hemodialysis patients (Carmichael, 2001). Dialysis centers should be aware of the potential presence of such toxins, particularly in areas subject to seasonal algae blooms.

B. **Water and dialysis solution quality requirements**

1. **Fluid quality standards.** The International Organization for Standardization (ISO) has developed minimum standards for the purity of the water used to prepare dialysis solution and the purity of the final dialysis solution. These standards have been adopted by the Association for the Advancement of Medical Instrumentation as national standards for the United States and are also followed by regulatory organizations in many other countries. The standards set maximum levels for chemicals known to be toxic to hemodialysis patients, for chemicals known to be toxic to the general population, and for bacteria and their endotoxins.

Current recommendations are that product water used to prepare dialysis solution should contain **<100 colony-forming units (CFU)/mL** of bacteria and **<0.25 endotoxin units (EU)/mL** of endotoxin. The maximum levels for the final dialysis solution are 100 CFU/mL and 0.5 EU/mL, respectively. Pyrogenic reactions do not occur when levels of bacteria and endotoxins in the dialysis solution are maintained below these limits.

2. **Ultrapure dialysis solution.** Low levels of endotoxins and endotoxin fragments in dialysis solution, while not causing pyrogenic reactions, may contribute to a chronic inflammatory response that may be associated with long-term morbidity in dialysis patients. In observational studies, the use of so-called "ultrapure" dialysis solution, which is characterized by a **bacteria level below 0.1 CFU/mL** and **endotoxin level below 0.03 EU/mL**, has been linked to reduced plasma levels of C-reactive protein and interleukin-6, an improved response of anemia to erythropoietin therapy, better nutrition as evidenced by increases in plasma albumin value, and higher estimated dry body weight, midarm muscle circumference, and urea nitrogen appearance rate. Ultrapure dialysis solution has also been associated with reduced plasma levels of β_2 -microglobulin and pentosidine (a surrogate marker of carbonyl stress), a slower loss of residual renal function, and lower cardiovascular morbidity (Susantitaphong, 2013).

Although not all of the above benefits have been fully confirmed, many authorities believe that ultrapure dialysis solution should be used routinely. While use of ultrapure dialysis solution is highly desirable for hemodialysis, it is mandatory for online convective therapies such as online hemodiafiltration (see Chapter 17), which

would otherwise increase transfer of bacterial fragments from dialysis/replacement solution to the blood.

C. **Methods of purifying water for hemodialysis.** Systems used to purify water for dialysis consist of three parts: pretreatment, primary purification, and distribution to the point of use.

1. **Pretreatment.** These components usually include a valve to blend hot and cold water to a constant temperature, some form of preliminary filtration, softening, and filtration through activated carbon. This cascade is designed to prepare the water for optimal operation of the primary purification process. Correction of pH (using injection of hydrochloric acid) is sometimes needed to correct excessive alkalinity, which can impede the ability of carbon beds to remove chlorine and chloramine and can cause fouling of reverse osmosis (RO) membranes by calcium and magnesium salts.

a. **Water softener.** A water softener is used to remove calcium and magnesium from water by exchange for sodium bound ionically to a resin bed. The resin exchanges Na^+ ions for Ca^{++} and Mg^{++} as well as for other cations such as iron and manganese. The water softener protects the downstream RO membrane from scaling by calcium and magnesium in the source water. Such mineral scale can foul an RO membrane quickly. Water softener resins need to be backwashed and regenerated frequently on a routine basis using a concentrated sodium chloride solution (brine). During backwash, water is drawn into the softener in a reverse direction to wash and fluff the resin, and then the brine solution is introduced to regenerate the resin, replacing the recently bound Ca^{++} and Mg^{++} ions with Na^+ ions.

b. **Carbon.** Activated carbon is utilized to remove chlorine and chloramine, which are not removed by RO. Carbon also removes other small organic compounds that may be in the water. Chlorine can combine with organic substances in the water to form potentially cancer-causing compounds. As a consequence, many municipalities that previously used chlorine to suppress bacterial proliferation have changed over to using chloramine. The kinetics of the reaction through which carbon removes chloramine from water are slower than those for the removal of chlorine so that systems that adequately removed chlorine might not adequately remove chloramine. Chlorine or chloramine can permanently damage the downstream RO membrane. Importantly, chloramine can cause hemolytic anemia, and so this part of the water purification process needs to be monitored extremely closely. In the past, some municipalities did not notify dialysis units of the change from chlorine to chloramine in the water supply, and outbreaks of hemolytic anemia have been reported in the course of such changeovers.

Because of the critical need to remove chloramine and related organics, the water stream is run through two carbon beds in series. The upstream “worker” carbon bed will become exhausted first. The downstream or “polisher” carbon bed is used as a backup. This strategy permits sequential replacement as the upstream carbon bed becomes exhausted. Any exhausted carbon bed tank needs to be replaced as soon as possible. Although the levels of chlorine and chloramine can be determined separately, it is simpler to measure total chlorine—the sum of

chlorine and chloramine—and replace exhausted carbon beds based on that measurement. If the municipal water contains chloramine, the total chlorine level in the water exiting the primary “worker” carbon bed needs to be checked before each dialysis shift. If breakthrough is noted, the total chlorine level should be checked downstream of the “polisher” bed. If no breakthrough is noted at that point, treatments can be continued while closely monitoring the outflow from the downstream “polisher” carbon bed. If total chlorine breakthrough is noted downstream of the “polisher” bed, treatments must cease immediately.

One critical aspect to proper functioning of granular activated carbon beds is the contact time of the water with the carbon. This “empty bed contact time” must be at least 10 min, to help ensure removal of chlorine and chloramine. Regular backwashing of the carbon beds with water fluffs the beds and prevents the formation of channels in the carbon, which reduce their efficiency. Optimal removal of chloramine by carbon may require adjustment of the pH of the feed water. Even with pH adjustment, carbon may provide inadequate removal of chloramine if the water contains corrosion inhibitors or other substances that prevent chloramine molecules from reaching the surface of the carbon. In those situations it may be necessary to use alternative methods of chloramine removal such as injection of sodium bisulfite.

2. **Primary purification process.** The primary purification process is almost always RO. A filter is normally placed just upstream of the RO membrane to catch any carbon particles and resin beads that may have been inadvertently released from the pretreatment system.
 - a. **Reverse osmosis.** This is achieved by high pressure filtration of water (using a powerful pump) through a semipermeable membrane that will hold back dissolved solutes. RO will remove more than 95% of ionic contaminants and nonionic contaminants as small as glucose. In addition, it provides an effective barrier against bacteria and endotoxins. In many cases, RO will provide water of sufficient quality for the preparation of dialysis solution without further purification.
 - b. **Deionization.** Deionization may be used as an alternative to RO, but is more frequently used to further purify water following processing by RO. Deionizers do not remove nonionic contaminants, bacteria, or endotoxins. A solid-phase deionizer contains both cationic and anionic resins. These can be configured as either two beds (one for the cationic resin and the other for the anionic resin) or as a single bed containing a mixture of both resins. Cationic resins contain sulfuric groups and these exchange hydrogen ions for other cations such as sodium, calcium, and aluminum. Anionic resins contain ammonium groups, which exchange hydroxyl ions for other anions such as chloride, phosphate, and fluoride. The hydrogen and hydroxyl ions released during the exchange process then combine to become water, resulting in a product water that contains very few residual ions.

Deionizer function is monitored by checking the conductivity of the outflow water; the fewer the ions that remain in the water, the lower the conductivity.

When the resins in a deionizer tank have exchanged all their available hydrogen and hydroxyl ions for cations and anions from the water, its capacity to remove ions is “exhausted.” The conductivity of the outflow water increases following exhaustion, signaling that the tank needs to be replaced. It is important to know that an “exhausted” deionizer resin is not inactive, but will rapidly release the ions that are most weakly bound to the resin if it continues to be used, with potentially serious adverse consequences for the patient. For example, failure to remove exhausted deionizer tanks led to patient deaths following the release of massive amounts of fluoride into the dialysis water (Arnow, 1994). For this reason, it is important to move exhausted deionizer tanks offline as soon as evidence of increased conductivity appears. All ion exchange tanks are required to be fitted with online monitors that continuously monitor the conductivity of the outflow water and divert that water away from the patients should it exceed 1 mS/cm (a resistivity of 1 M Ω -cm). Additionally, some tanks also have a light that is normally off, and then turns on when the outflow conductivity increases, or a light that is normally on, and which turns off when conductivity monitoring fails. If there is a light, it is very important to know which type it is.

The resin of deionizers presents a large surface area for bacterial proliferation. Since all bacteriostatic substances such as chlorine and chloramine will have been removed from the water by the time it reaches a deionizer, the level of bacterial contamination of the water flowing through deionizer tanks is subject to increase. For this reason, an ultrafilter usually is placed downstream to the deionizer to remove any bacteria or endotoxin that may have accumulated from the deionizer tanks. Some centers also prefer to destroy bacteria (whether in a vegetative or a sporulated state) with ultraviolet radiation. However, the UV process can increase the lipopolysaccharide and peptidoglycan content of the treated water due to bacterial death.

3. **Distribution of purified water.** Purified water intended for the preparation of dialysis solution must be distributed to the individual dialysis machines to produce dialysis solution that remains free of contaminants. Chemical contaminants are avoided by using inert materials, such as plastics, for all components that contact the purified water and dialysis solution. Microbiologic contamination is avoided by using appropriately designed and constructed piping systems in combination with regular disinfection. The water distribution system is configured in a loop without multiple branches or dead ends. If the distribution system includes a storage tank (ideally, the use of a storage tank should be avoided), the tank is of the minimum required size, has a tight-fitting lid, and is designed for ease of disinfection.

Water storage and distribution systems are disinfected on a regular schedule to prevent bacterial colonization of the system and minimize the formation of biofilm, which, once established, is very difficult to remove. When chemical germicides are used, disinfection is generally performed at least monthly. The disinfection schedule should be designed to minimize biofilm formation in the storage and distribution system, not to eliminate biofilm after it has formed. Distribution systems are now

available that can be disinfected with hot water or ozone. These systems allow more frequent disinfection because there is no need to rinse the system free of residual germicide. Water and dialysis solution cultures and endotoxin tests are performed to demonstrate the adequacy of the disinfection schedule.

4. **Bicarbonate concentrate mixing and distribution systems.** These include containers used to distribute centrally prepared concentrate to individual dialysis machines, which are disinfected frequently because bicarbonate concentrates are particularly susceptible to bacterial contamination.
- D. **Safety standards and monitoring.** Careful procedures and documentation of the functioning of each part of the water supply system must be done. Both ISO and the European Best Practices Group have developed standards for equipment used to purify water for dialysis that are designed to maximize patient safety. These include chemical purity monitoring of water and dialysis solution. Chloramine levels are checked for at least daily. Absence of other chronic toxic components from the feed water must be verified on a regular basis. Both water and dialysis fluid must be checked using high-sensitivity methods for bacterial growth and presence of endotoxin. Finally, the patients themselves must be monitored, being always alert for evidence of unexplained clusters of hemolytic, pyrogenic, or other unusual reactions.

In the United States, the Forum of ESRD Networks Medical Advisory Council has prepared a Medical Director Toolkit to assist dialysis units in meeting the requirement of the “Conditions for Coverage” (DeOreo, 2012). This document details not only monitoring of various parts of the water system but also the need to comply with required remote alarms, training, and planning in the event of emergencies.

II. DIALYSIS SOLUTION PREPARATION

- A. **Proportioning machines.** To reduce bulk and shipping costs, dialysis fluid is manufactured in concentrated form and machines proportion it with water before delivering it to the dialyzer. The dialysis machine incorporates pumps and one-way valve systems that make the final dialysis solution by taking fixed volumes of dialysate concentrates and mixing them with a fixed volume of heated purified water, or by using conductivity-based servocontrol systems to mix the concentrates and water. As discussed in the previous chapter, the ionic composition of the final dialysis solution is checked by conductivity, which is kept in a very tight range. As long as the solution remains in the target conductivity range, the dialysis solution is allowed to pass on to the dialyzer. If conductivity gets outside the range, an alarm sounds and dialysis stops.
- B. **Dual-concentrate system for bicarbonate-based solutions.** Almost all dialysis solution used today is bicarbonate based, and this engenders a solubility issue. When making a bicarbonate solution of about 30 mM, the pH will be close to 8.0. At this pH, calcium and magnesium will precipitate out from solution, reducing their diffusible concentration and also contributing to scaling on dialysis machine lines and passages. To circumvent the problem of calcium and magnesium precipitation, a bicarbonate-based dialysis solution-generating system utilizes two concentrates: a “bicarbonate” concentrate and an “acid” concentrate. The “acid” concentrate contains a small amount of acetic or citric acid plus sodium,

potassium (as needed), calcium, magnesium, chloride, and dextrose (optional). The low pH of the acid concentrate keeps the calcium and magnesium in solution, even in concentrated form.

Specially designed double proportioning systems mix the two concentrates sequentially with purified water to make the final dialysis solution. During mixing, the small amount of acetic acid in the “acid” concentrate (about 2–4 mM) reacts with an equimolar amount of bicarbonate in the “bicarbonate” concentrate to generate carbon dioxide. The carbon dioxide generated forms carbonic acid, which lowers the pH of the final bicarbonate-containing solution to approximately 7.0–7.4. At this pH range, the calcium and magnesium in the product dialysis solution remain dissolved. The ratio of “acid” concentrate to “base” concentrate to water in the various proportioning systems available depends on the machine manufacturer. Liquid “acid” concentrates are available between 35 times and 45 times concentrated, and the corresponding liquid “bicarbonate” concentrates are also concentrated differently. In units using more than one brand of dialysis machine, it is important to use concentrate designed for the proportioning ratio of a given machine.

The bicarbonate level shown on the monitor of many dialysis machines that allow for adjusting dialysis solution bicarbonate by altering the concentrate proportioning ratio is the final bicarbonate concentration and does not take into account the acetate of sodium acetate that was produced from reaction of acetic acid with an equimolar amount of sodium bicarbonate. This acetate will generate bicarbonate as it is metabolized in the body on an equimolar basis. Thus, the actual base content of the dialysate used will be higher than that shown on the monitor (Kohn, 2012). With most liquid acid concentrates containing acetic acid, the amount of acetic acid, and hence that of acetate present in the product dialysate after mixing commonly is about 4 mM.

C. Dry concentrates

1. **Bicarbonate.** In some machines, a cartridge containing dry sodium bicarbonate is used in place of a liquid “bicarbonate” concentrate. Use of dry bicarbonate cartridges obviates the problem of bacterial growth in “bicarbonate” concentrate and the concern of subsequent contamination of the final dialysis solutions.
2. **Acid (citric acid or sodium diacetate).** While acetic acid is a liquid, dry “acid” concentrates can be made using either citric acid or sodium diacetate. The low concentration of citrate generated in citric acid–based dialysis solution may chelate plasma calcium that is adjacent to the dialysis membrane, impeding coagulation, improving dialyzer clearance slightly, and increasing the dialyzer reuse number. In dry acid concentrates containing citric acid (0.8 mM) plus a small amount (0.3 mM) of acetic acid, after mixing, the dialysis solution will contain 0.8 mM citrate (2.4 mEq/L) and 0.3 mM acetate, yielding about 2.7 mEq/L of bicarbonate-generating base.

TABLE

5.1

Composition of a Standard Hemodialysis Solution

Component

Concentration (mM)

Sodium	135–145
Potassium	2–3
Calcium	1.25–1.75 (2.5–3.5 mEq/L)
Magnesium	0.25–0.375 (0.5–0.75 mEq/L)
Chloride	98–124
Acetate ^a	3–8
Citrate ^a	0.8–1.0 (2.4–3.0 mEq/L)
Bicarbonate	25–35
Glucose	0–11
pCO ₂	40–110 (mm Hg)
pH	7.1–7.3 (units)

^a The acetate or citrate is added in the form of acetic acid, sodium diacetate, or citric acid to the “acid concentrate.” When mixed with the “bicarbonate concentrate,” the hydrogen ion from either of these acids reacts with bicarbonate to form CO₂ (i.e., carbonic acid) to establish a buffer system.

Sodium diacetate is a compound containing acetic acid and sodium acetate. Acid concentrates formulated with sodium diacetate typically contain twice the concentration of acetate in the final dialysate compared to those using acetic acid. It is important to take this relatively high concentration of acetate (up to 8 mM) into account as an additional source of bicarbonate-generation (Kohn, 2012).

- D. **Final dialysis solution composition.** The composition range of typically used dialysis solutions is given in Table 5.1. The concentrations of sodium, potassium, and calcium can be varied by choosing different “acid” concentrates or by adding salts of these cations to the appropriate “acid” concentrates prior to use. In addition, some dialysis machines allow the concentration of sodium in the dialysis solution to be varied during the course of an individual treatment—a practice known as sodium profiling. Sodium profiling may help reduce the tendency to intradialytic hypotension and the postdialysis washed-out feeling in some patients, but whenever the average dialysis solution sodium level is increased, this may predispose to increased thirst, excessive fluid intake, and hypertension (see Chapter 12). Most dialysis machines allow the bicarbonate level to be varied without changing to a different concentrate by altering the proportioning pump ratio. This allows use of dialysis solution bicarbonate levels from 20 to 40 mM, and such a feature is particularly useful when more frequent dialysis is employed, when dialyzing nonuremic patients (e.g., to treat poisoning) or to treat alkalemic patients. Minor changes in calcium, magnesium, and potassium (if present) will take place whenever dialysate bicarbonate level is altered.
- E. **Disinfection of dialysis machines.** Dialysis machines are disinfected according to the manufacturer’s recommendations. The water inlet lines to the dialysis machines are disinfected at the same time as the water distribution system. Dialysis machines are now available that incorporate a bacteria- and endotoxin-retentive ultrafilter located in the dialysis machine itself. This filter intercepts the dialysis solution flow immediately before it is passed to the dialyzer. These dialysate ultrafilters, which are rated for a certain

number of treatments or months of operation, are disinfected when the dialysis machine is disinfected. Such ultrafilters facilitate the routine preparation of “ultrapure dialysis solutions.”

References and Suggested Readings

- Arnow PM, et al. An outbreak of fatal fluoride intoxication in a long-term hemodialysis unit. *Ann Intern Med.* 1994;121:339–344.
- Association for the Advancement of Medical Instrumentation. *Quality of Dialysis Fluid for Hemodialysis and Related Therapies, ANSI/AAMI/ISO 11663:2009*. Arlington, VA: Association for the Advancement of Medical Instrumentation; 2009.
- Association for the Advancement of Medical Instrumentation. *Water for Hemodialysis and Related Therapies, ANSI/AAMI/ISO 13959:2009*. Arlington, VA: Association for the Advancement of Medical Instrumentation; 2009.
- Association for the Advancement of Medical Instrumentation. *Water Treatment Equipment for Hemodialysis and Related Therapies, ANSI/AAMI/ISO 26722:2009*. Arlington, VA: Association for the Advancement of Medical Instrumentation; 2009.
- Association for the Advancement of Medical Instrumentation. *Guidance for the Preparation and Quality Management of Fluids for Hemodialysis and Related Therapies, ANSI/AAMI/ISO 23500:2011*. Arlington, VA: Association for the Advancement of Medical Instrumentation; 2011.
- Canaud B, et al. Microbiologic purity of dialysate: rationale and technical aspects. *Blood Purif.* 2000;18:200–213.
- Carmichael WW, et al. Human fatalities from cyanobacteria; chemical and biological evidence for cyanotoxins. *Environ Health Perspect* 2001;109:663–668.
- Damasiewicz MJ, Polkinghorne KR, Kerr PG. Water quality in conventional and home haemodialysis. *Nat Rev Nephrol.* 2012;8:725–734.
- DeOreo P, et al. Medical Director Toolkit. Developed by the Forum of ESRD Networks’ Medical Advisory Council (MAC). 2012. http://esrdnetworks.org/mac-toolkits/download/medical-director-toolkit-2/medical-director-toolkit/at_download/file. Accessed July 27, 2014.
- European Renal Association—European Dialysis and Transplantation Association. European best practice guidelines for haemodialysis, section IV—dialysis fluid purity. *Nephrol Dial Transplant.* 2002;17(suppl 7):45–62.
- Kohn OF, Kjellstrand CM, Ing TS. Dual-concentrate bicarbonate-based hemodialysis: Know your buffers. *Artif Organs.* 2012;36:765–768.
- Ledebo I. Ultrapure dialysis fluid—direct and indirect benefits in dialysis therapy. *Blood Purif.* 2004;22(suppl 2):20–25.
- Sam R, et al. Composition and clinical use of hemodialysates. *Hemodial Int.* 2006;10:15–28.
- Schindler R, et al. Short bacterial DNA fragments: detection in dialysate and induction of cytokines. *J Am Soc Nephrol.* 2004;15:3207–3214.
- Susantitaphong P, Riella C, Jaber BL. Effect of ultrapure dialysate on markers of inflammation, oxidative stress, nutrition and anemia parameters: a meta-analysis. *Nephrol Dial Transplant.* 2013;28:438–446.
- Ward DM. Chloramine removal from water used in hemodialysis. *Adv Ren Replac Ther.* 1996;3:337–347.

Ward RA. Ultrapure dialysate. *Semin Dial*. 2004;17:489–497.

Ward RA. Dialysis water as a determinant of the adequacy of dialysis. *Semin Nephrol*. 2005;25:102–110.

6

Arteriovenous Fistulas and Grafts: The Basics

Tushar J. Vachharajani, Steven Wu,
Deborah Brouwer-Maier, and Arif Asif

I. INTRODUCTION: TYPES OF VASCULAR ACCESS. Arteriovenous (AV) fistulas and grafts are the commonest forms of vascular access used for maintenance hemodialysis. An AV fistula involves creating an anastomosis between an artery and a native vein, allowing the blood to flow directly from the artery to the vein. Traditionally, the anastomosis is made at the wrist between the radial artery and the cephalic vein, although there are many variations possible, with anastomoses in the snuffbox, in the forearm area, or at the elbow or upper arm. An AV graft is similar, except that the distance between the feeding artery and vein is bridged by a tube made of prosthetic material. The most commonly used bridging material is polytetrafluoroethylene (PTFE) polymer. A third type of access, the cuffed venous catheter, is discussed in the following chapter.

An AV fistula cannot be used immediately as the fistula maturation process generally takes about 6–8 weeks. During the maturation process blood flow through the newly created fistula will gradually increase due to dilatation of both artery and vein. Pressure and flow–induced remodeling (thickening) of the wall of the fistula vein, which is the section where the needles will be inserted, strengthens the fistula and limits tearing and extravasation, while dilatation of the vein facilitates future needle insertion. An AV graft can be used earlier than a fistula, generally within 1–3 weeks after placement.

A well-functioning fistula remains the preferred access compared to a graft due to a fistula’s lower incidence of infection, higher patency rates, and overall better patient survival. However, AV fistulas have their problems as well, one important downside being a poor maturation rate in those with unsuitable blood vessels, including many elderly patients. An AV graft can be a suitable initial choice of access in patients with insufficiently large or poorly distensible blood vessels. With prolonged use, some dilatation of the vein downstream to an AV graft typically occurs, and sometimes this newly enlarged vein segment can then be connected directly to an artery, converting the graft to a fistula.

A. Neointimal hyperplasia. Mechanistically, an AV graft is a less desirable vascular access option than an AV fistula because with a graft there is a higher risk of neointimal hyperplasia. Most commonly, this occurs in the venous segment downstream from the graft–vein anastomosis. Hyperplasia obstructs the lumen of the downstream vein, leading to poor flow in the graft and prolonged bleeding after removal of dialysis needles (due to increased

intra-graft pressure). Eventually, this leads to graft thrombosis. The cause of accelerated neointimal hyperplasia in AV grafts is thought to be turbulence downstream to the graft–vein anastomosis, and also to a compliance mismatch between the relatively rigid graft and the more flexible vein. Periodic exposure of this vulnerable vein segment to activated blood exiting the dialyzer may accelerate the process, although stenosis can develop downstream to an AV graft even when the graft is left unused.

Although an AV graft is an inferior access option compared to a mature AV fistula, it is superior to a central venous catheter. Patients with either AV fistula or AV graft have less serious infections, lower morbidity, and higher survival rates than patients managed with venous catheters. Recently, some of the poorer results with central venous catheters have been shown to be due to selection bias (venous catheters tend to be used in sicker patients), and the infection risk with venous catheters, especially in elderly patients, has been found to be relatively low (Murea, 2014). Thus, in certain clinical circumstances discussed more thoroughly in the next chapter, the chronic venous catheter remains a useful form of vascular access.

II. GUIDELINES TARGETING INCREASED USE OF AV FISTULA. Guidelines developed by the National Kidney Foundation’s Kidney Disease Outcomes Quality Initiative (KDOQI) and the “Fistula First” initiative (see web references) promote construction of AV fistulas, targeting at least 68% use in prevalent patients on dialysis. Early referral of CKD patients to nephrologists prior to the start of hemodialysis allows more time for construction of an AV access. This avoids the risks of a central vein catheter that is usually required when the patient is referred for dialysis late in the course of chronic kidney disease. Recently “urgent start peritoneal dialysis” has been advocated as an initial treatment method for patients who urgently need dialysis. This allows such patients to be stabilized without subjecting them to a chronic venous catheter. One key factor to increasing AV fistula use is the presence of a dedicated and trained access surgeon functioning as part of a vascular access team.

Over the past decade, since the implementation of the US Government sponsored fistula first breakthrough initiative, the AV fistula rate in the US prevalent hemodialysis patients has increased from 26% to 61%. Many US Centers and European centers achieve much higher percentages ($\geq 90\%$). In the United States, however, the central venous catheter use rate has not declined as much as planned, leading to a revision of the initiative goal from “fistula first” to “fistula first and catheter last.”

III. VESSEL PRESERVATION. In patients with progressive CKD who are expected to require dialysis, superficial and deep veins of both arms must be protected, anticipating their possible use for vascular access. Accordingly, one should minimize venipunctures and placement of peripheral infusion lines in the upper extremity, especially in the cephalic and antecubital veins of either arm. The veins on the dorsum of the hand should be used whenever possible. Because of the risk of subsequent central vein stenosis, the subclavian vein should not be cannulated unless absolutely necessary and use of percutaneously inserted central catheter (PICC) lines and midline catheters should be rejected, also. The radial and brachial arteries need to be preserved for future AV access creation, and so cardiac and other endovascular percutaneous interventions

should not be done through these arteries. Placement of endovascular leads for a cardiac implantable electronic device (CIED) should be avoided as well, as this can adversely affect patency of the central veins; plus, the long-term risk of infection will be high. Instead, CKD patients who require a pacemaker or similar device should be evaluated for approaches utilizing epicardial as well as subcutaneous lead placement.

- A. **The American Nephrology Nurses Association “Save the Vein” project.** This organization has a website (See Web References) that offers patient-targeted brochures in English or Spanish describing the importance of preserving arm veins. The website also has links to a supplier for patient wristbands bearing the inscription: “Save Veins • No IV / LAB Draws.”

IV. ARTERIOVENOUS ACCESS PLANNING

- A. **Patient education and timing issues.** Patients with a glomerular filtration rate (GFR) of <30 mL/min per 1.73 m² should be educated about all renal replacement modality options including peritoneal dialysis and renal transplantation. For those choosing hemodialysis, an AV fistula should be placed at least 6 months prior to the planned initiation of dialysis. In patients planning to start peritoneal dialysis, creation of an AV fistula is optional. A backup AV fistula is sometimes created in a peritoneal dialysis patient to avoid the risks associated with central vein catheters when peritoneal dialysis must be stopped for a time; for example, to replace the catheter because of malfunction or severe peritonitis. However, peritonitis rates are much lower now than in the past, so most centers no longer create such backup fistulas. Patients who are planning to receive a live donor kidney in the near future but who need dialysis for a short time can be managed without a permanent AV access. In such patients, short-term use (<6 months) of a cuffed venous catheter for access may be appropriate unless the patient has a contraindication to venous catheter use (such as valvular heart disease, which might predispose to endocarditis).
- B. **Predicting the need for dialysis.** Anticipating the need for dialysis correctly is not always a simple task. Premature creation of an AV access is an unnecessary utilization of resources, and many elderly patients, especially, have been shown to die before needing dialysis. One tool that may help in predicting the need for renal replacement therapy was developed by Tangri (2011, 2013), though their equations predict the risk of developing ESRD over a time window of 3 years. A similar predictive equation based on male US Veterans Affairs patients was developed by Drawz (2013), which predicts the risk of ESRD over a 1-year period.

V. PREOPERATIVE EVALUATION

- A. **Patient history.** A thorough history is required, querying about previous episodes of central vein catheters or intravenous pacemaker/CIED implantation, prior use of PICC lines, and prior vascular surgery. Comorbid conditions such as congestive heart failure, diabetes mellitus, or peripheral vascular disease may limit options for access construction. Patients with severe heart failure may not tolerate the additional cardiac output required to circulate blood through the access. Patients with severe vascular disease due to atherosclerosis or diabetes or patients with extensive damage to their arm veins due to prior needle sticks or failed AV fistula may not have adequate blood vessels to support creation of an AV access,

although even in such patients an AV fistula often can be created in the upper extremity using innovative surgical techniques.

- B. **Physical examination:** The presence of all pulses in upper extremity (axillary, brachial, radial, and ulnar) should be evaluated and recorded. The blood pressure in both arms should be measured, and the difference between the arms should be graded as normal if <10 mm Hg, borderline if 10–20 mm Hg, or problematic if >20 mm Hg. The Allen test, which measures collateral flow between the radial and ulnar arteries at the palmar arch, can be either done by physical exam or aided by Doppler (see what follows). The sensitivity of the Allen test can be increased if combined with pulse oximetry (Paul and Feeny, 2003). Details of how to perform the Allen test are given in Table 6.1. The patient should be examined for evidence of previous central or venous catheterization and for signs of trauma or surgery of the arm, chest, or neck, including previous AV access surgery. The presence of arm edema, collateral veins, or differential extremity size should prompt an evaluation of the central veins.
- C. **Imaging studies.** Routine preoperative mapping of the arm to evaluate veins and arteries helps with selection of the most appropriate vein and the best location to create an access. Use of imaging studies has been shown to increase the rate of well-functioning fistula placements.
1. **Doppler ultrasonography.** Doppler ultrasonography, which can measure flow velocity as well as the inner diameter of the brachial and radial arteries and peripheral veins, should be performed in all patients to identify suitable arteries and veins for access placement. The poor visualization of central veins on Doppler ultrasonography is a limitation of this method. Doppler ultrasonography is best performed in the operating room after regional anesthesia of the arm by nerve block, as the veins tend to dilate postanesthesia administration; under normal circumstances, these veins can be constricted and may not be visualized properly.

TABLE

6.1

Allen Test (Test of Palmar Arch Patency)

1. Position the patient so that they are facing you with their arm extended with the palm turned upward
3. Compress both the radial and ulnar arteries at the wrist
3. With the arteries compressed firmly, instruct the patient to create a fist repetitively in order to cause the palm to blanch
4. When the patient's hand is blanched, release the compression of the ulnar artery and watch the palm to determine if it becomes pink. Then release all compression
5. Repeat steps 2–4 for the radial artery

Interpretation: When color returns to the blanched palm upon release of the arterial compression it indicates arterial patency and reflects upon adequacy of flow. Blanching that persists for ≥ 5 s after release of the ulnar artery is a positive test for ulnar artery insufficiency. Likewise, blanching that persists for ≥ 5 s following release of the radial artery is positive for radial artery insufficiency

- a. **Minimal vein and artery size.** Controversy exists about the minimum size of the feeding artery and target vein for a successful fistula. Studies suggest that the minimum vein lumen diameter should be about 2.5 mm for successful surgical anastomosis (Okada and Shenoy, 2014) and minimal arterial diameter should be 2.0 mm. Smaller, "borderline" vessels down to 1.5 mm (for both artery and vein) have been used to create successful fistulas, but this may require an experienced surgeon with skills to operate on such small vessels (Pirozzi, 2010). More important may be the ability of the artery and vein to dilate after anastomosis, to allow an increase in flow.
 - b. **Vein dilation test.** During the Doppler study the proximal vein is occluded using a tourniquet and the increase in size is recorded. An average increase in internal diameter of 50% has been associated with successful fistula outcome (Malovrh, 2002).
 - c. **Arterial dilation test.** During the Doppler study the pulse contour of the artery is examined. The pulse contour of the artery is normally triphasic, due to high peripheral resistance. The patient is asked to clench the fist for 2 minutes, and then to open the hand; the resulting hyperemic response normally converts the triphasic arterial pulse contour to a biphasic pattern in patients capable of a healthy arterial dilation.
 - d. **Mapping.** The cephalic and ulnar venous systems should also be evaluated for continuity and absence of strictures. Some surgeons perform venous mapping with a proximal tourniquet in place to distend and better identify veins suitable for AV fistula construction.
2. **Venography.** Venography should be reserved for evaluating the central veins, especially in patients with a history of transvenous placement of a pacemaker, physical findings of upper extremity edema, collateral veins around the shoulder or on the chest wall, and/or unequal extremity size. If venography is performed, 30 mL or less of nonionic, low osmolality contrast, diluted 1:4, should be used to avoid nephrotoxicity. Full-strength contrast is usually not required for venography. Venography alone does not help evaluate the arterial tree.
 3. **Arteriography.** Arteriography is indicated when pulses in the desired access location are markedly diminished or absent or there is a >20 mm Hg difference in mean arterial pressure between the two arms.

VI. POSSIBLE LOCATIONS FOR UPPER EXTREMITY AV FISTULAS. For an overview, see Okada and Shenoy (2014) (Table 6.2).

- A. **Arm fistula locations.** An AV fistula can be categorized as conventional or transposed, depending on its connection to the arterial and venous circulations. A **conventional AV fistula** is created by connecting a superficial artery and vein and generally does not require extensive mobilization of the vessels. A **transposed AV fistula** utilizes deeper veins and

requires extensive mobilization of the vein into a subcutaneous tunnel for easy needle access. Compared to conventional AV fistulas, transposed AV fistulas are technically more challenging to create and require greater healing time. Generally, conventional AV fistulas are created as a single-stage surgical procedure, whereas creation of a transposed AV fistula can be either a one-stage or two-stage procedure.

At least nine potential sites for AV fistula can be used in the upper extremity (Table 6.2). The **anatomical snuffbox** fistula is the distal variant of the radiocephalic fistula created between the tendons of *extensor pollicis longus* and *brevis*. The classic wrist **radiocephalic** or Brescia–Cimino fistula (Fig. 6.1) placed in the nondominant arm is the preferred access. Other forearm AV fistulas, such as the **ulnar artery–basilic vein** fistula, should be considered when a radiocephalic fistula is not an option. Before considering an upper arm site, several other transposed forearm sites should be evaluated; for example, the **forearm cephalic vein to proximal radial artery or brachial artery**, and the **transposed forearm basilic vein to radial artery or brachial artery**. If creating a forearm fistula is not possible, which happens not uncommonly in diabetic or elderly patients with atherosclerosis, then an **upper arm brachial artery–cephalic vein** fistula (Fig. 6.2), or a **transposed basilic vein–brachial artery** fistula (Fig. 6.3) are potential options. Less commonly used options are the **Gracz fistula** (which uses a perforating vein that arterializes both upper arm cephalic and basilic veins) and the **brachial bidirectional cephalic** fistula (which arterializes both forearm and upper arm cephalic veins). When a perforating vein fistula is used, it has been suggested that the original surgical procedure be modified (Konner, 1999). When all sites in the nondominant arm have been exhausted, then the dominant arm can be used.

TABLE

6.2

Sites for AV Fistula Creation in the Upper Extremity

Conventional

Snuffbox (distal-most site)

Radiocephalic or Brescia–Cimino (radial artery to forearm cephalic vein at the wrist)

Ulnar artery to forearm basilic vein (uncommon)

Brachial artery to upper arm cephalic vein (at the elbow)

Transposed

Forearm basilic vein to radial artery at the wrist

Forearm basilic vein to the brachial artery (loop configuration)

Forearm cephalic vein to the brachial artery (loop configuration)

Transposed basilic vein in the upper arm to the brachial artery

Perforating veins in the proximal forearm to proximal radial artery (Konner modification of the Gracz fistula)

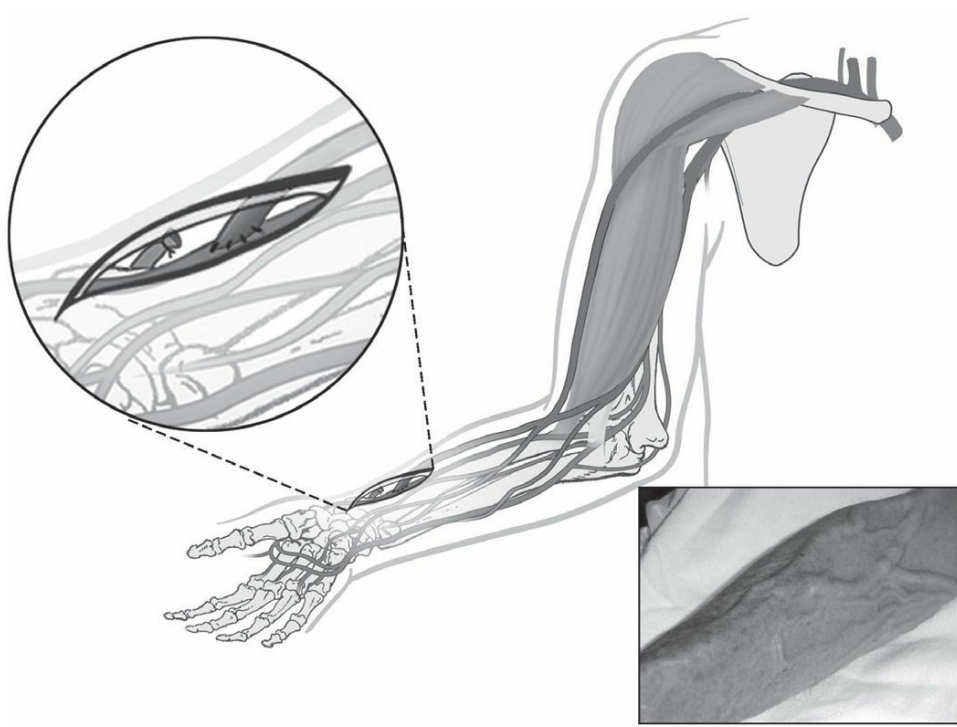

FIGURE 6.1 Radiocephalic AV fistula. (Reprinted with permission from Atlas of Dialysis Vascular Access—<http://www.fistulafirst.org>.)

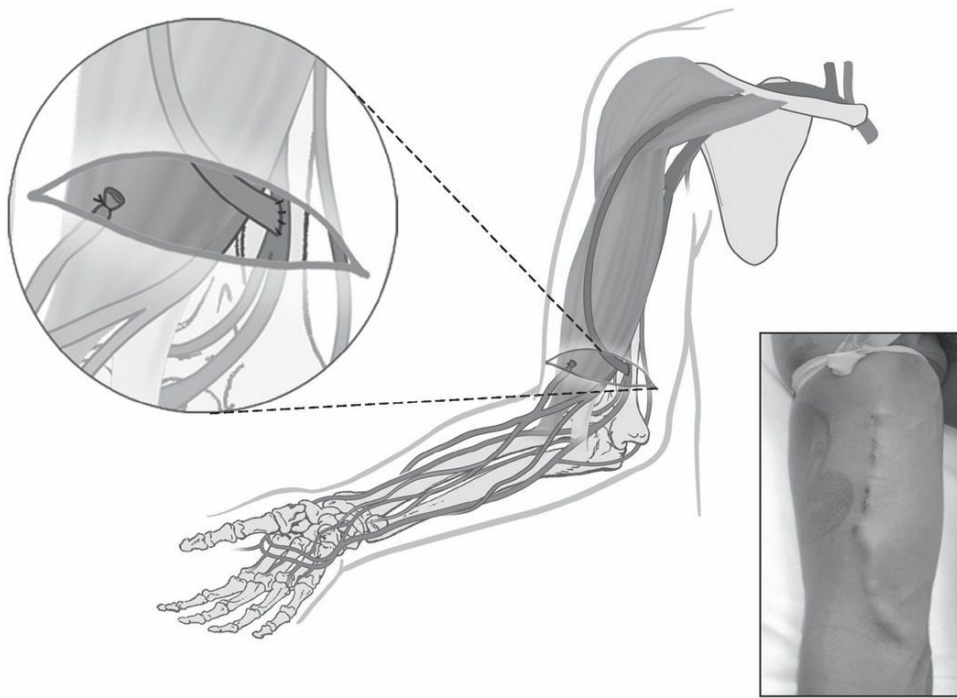

FIGURE 6.2 Brachiocephalic AV fistula. (Reprinted with permission from Atlas of Dialysis Vascular Access—<http://www.fistulafirst.org>.)

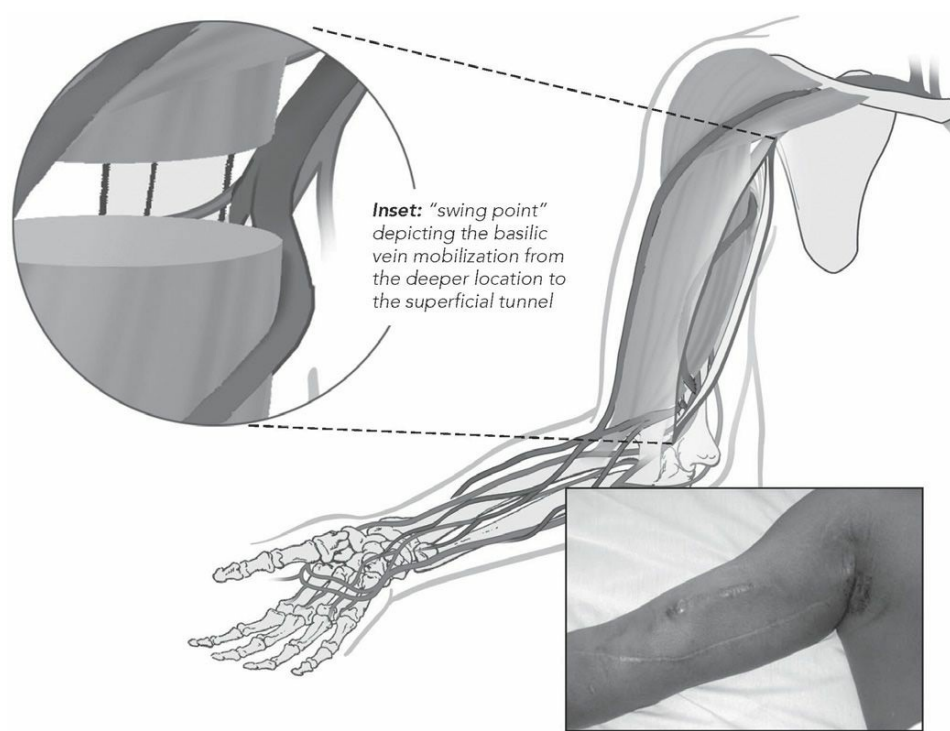

FIGURE 6.3 Transposed basilic vein to brachial artery AV fistula. (Reprinted with permission from Atlas of Dialysis Vascular Access—<http://www.fistulafirst.org>.)

1. **Initial selection of elbow perforating vein fistula for patients who are elderly or with comorbidities.** In such patients, a calcified radial artery with a small lumen and thickened wall is a common finding, and fistulas fed by such arteries are likely to fail. In one small study (Palmer, 2011), a forearm fistula was performed only if the diameter of the radial and ulnar artery were >2.0 mm at the wrist and no calcification or segmental stenosis was detected. Also, with tourniquet in place at the wrist the cephalic vein diameter had to be at least 2.5 mm. If not, and if a perforating vein was present at the elbow, and the brachial artery and cephalic vein were of suitable diameter, a perforating vein AV fistula was created at the elbow, using the Konner modification (discussed earlier) of the Gracz approach. In the group of elderly patients with poor blood vessels getting the perforating vein elbow fistula, fistula patency rate at 24 months was an impressive 78%.
 - B. **Fistulas in the leg.** AV fistulas in the lower extremity are created rarely, because of a higher complication rate and poorer outcome, but they remain an option once all potential sites in the upper extremity have been exhausted. The possible sites include fistulas connecting the superficial femoral artery to the femoral vein or the saphenous vein to the popliteal artery.
 - C. **Steal due to fistula on the same side as an internal mammary artery– coronary artery bypass graft.** This has now been widely reported, and in such patients, a contralateral AV fistula should be inserted to avoid this problem (Coskun, 2013).
- VII. OPERATIVE PROCEDURE FOR AN AV FISTULA .** AV fistula surgery is usually performed in the operating room under regional anesthesia. The anastomosis can be either side of artery to side of vein or side of artery to end of vein. In both instances, distal blood flow through the artery is preserved. With the side-to-side method, higher pressures may sometimes be transmitted to the

distal veins in the hand, causing swelling and the so-called “red hand syndrome.” The side-of-artery to end-of-vein anastomosis prevents venous hypertension in the hand because the distal vein is ligated off. A modified “piggyback SLOT technique has been shown to substantially reduce torsion in the anastomosed vein and to reduce juxta-anastomotic stenosis (Bharat, 2012). The details of the operative techniques are beyond the scope of this book. It is important to emphasize that AV fistula placement is not something that can be relegated to a junior or inexperienced vascular surgeon, but is best done by a surgeon with both experience and interest in performing these sometimes complex and demanding procedures.

- A. **Measuring radial artery fistula blood flow at time of surgery.** The radial artery normally has a flow rate of 20–30 mL/min, and this flow increases to 200–300 mL/min immediately after creation of the anastomosis (Konner, 1999). In one study of forearm fistulas, the flow in the anastomosed vein was measured immediately after surgery, and an immediate flow rate <120 mL/min was highly predictive of subsequent fistula failure (Saucy, 2010).
- B. **Predicting matured fistula blood flow using a computational algorithm.** A consortium of investigators have developed an algorithm to predict ultimate fistula flow rate for various types of fistula, based on baseline patient demographic variables, and preoperative Doppler measurements of vessel diameters and flows (Caroli, 2013). This algorithm is not yet widely used clinically.

VIII. PERIOPERATIVE CARE AND FISTULA MATURATION. Some centers prepare the patient for AV fistula surgery by having the patient perform arm exercises for several weeks prior to surgery, with the idea that this might help the vein to dilate and achieve a luminal size of more than 2.5 mm. Following surgery, the arm should initially be kept elevated. Tight circumferential dressings should be avoided. Hand exercises (e.g., squeezing a rubber ball or a soft handgrip device) may help increase fistula blood flow and pressure, and are believed by some to assist with the maturation of an AV fistula; a concept that has never been confirmed in a randomized trial. The fistula should never be used for venipuncture. Fistula blood flow should be checked daily (more frequently initially) by feeling for a thrill at the anastomotic site and by listening for an associated bruit. A physician, nurse, dialysis technician, or even a well-informed patient should be able to perform a physical examination of an AV fistula. The basics of physical examination of an AV access are described later in this chapter.

- A. **Rule of sixes.** All new AV fistulas should be examined within 4–6 weeks of creation for signs of maturation. At the time of intended use, the vein diameter should be at least 6 mm. A mature AV fistula should follow the “rule of 6”—it should be 6 mm in diameter, less than 6 mm below the skin, have a blood flow of at least 600 mL/min, and include a straight segment for cannulation that is at least 6 cm in length. Generally, maturation should occur by around 6 weeks after surgery.
- B. **Details of fistula maturation.** An experienced and well-trained examiner can clinically differentiate between a mature and an immature AV fistula. The fistula must be allowed to mature, as premature attempts to cannulate it can be associated with infiltration, compression of the vessel, and permanent loss of the fistula. Primary maturation failure of an AV fistula can result from an atherosclerotic artery, inadequate anastomosis, or an inability of the artery and/or vein to dilate due to vessel damage, for example, due to

preexisting vascular calcification or sclerosis. One remediable cause is the presence of multiple tributary branches in the vein draining the AV fistula. These branches can siphon off the increased venous flow, lessening the flow-induced increase in fistula pressure that induces maturation of the main venous channel. Often ligation of such side branches can bring about or hasten the maturation process. If a fistula cannot be cannulated or support dialysis therapy ≥ 6 weeks after placement, an imaging fistulogram should be obtained to determine the source of the problem.

IX. INITIAL TRIAL CANNULATION OF A NEW AV FISTULA. If physical assessment has shown that the fistula has adequately matured, the next step is to perform a trial cannulation.

- A. **Day of the week.** If possible, the initial trial cannulation should be done on a nondialysis day. This eliminates potential complications associated with the administration of heparin. If a trial cannulation is not possible, it is best to perform the initial cannulation of the new access at the patient's midweek treatment. Performing the initial cannulation midweek helps minimize such complications as fluid overload and elevated chemistry test results associated with dialysis after a long weekend interval.
- B. **"Wet needle" technique.** To ensure that the needle is placed properly, needle placement should be confirmed with a normal saline flush before connecting the needles to the blood pump and starting the pump. Blood return alone is not enough to show good needle placement. One option to check for proper needle placement is the use of "wet" needles. The needle is purged of air and the saline in the attached syringe is used to flush the needle. If an infiltration has occurred, the normal saline is less harmful to the surrounding AV fistula tissue. The wet needle also prevents the risk for a blood spray or spill if dry needles are used for cannulation and the caps are opened to "bleed out" air from the needle. Opening of the needle tubing cap creates a risk for blood exposure to the dialysis team member, patient, and nearby patients.
- C. **Needle with a "backeye."** A needle with a backeye should always be used for the arterial needle to maximize the flow from the access and reduce the need for flipping the needle.
- D. **Needle size selection.** Needle size selection for the initial cannulation is critical. Visual and tactile examinations allow the cannulator to determine which needle gauge would be most appropriate, based on the size of the vessel. One can place a 17G or a 16G needle with its protective cap in place (prevents needle stick) over the cannulation site. One then compares the vein size with the needle size with and without a tourniquet being applied. If the needle is larger than the vein when the tourniquet is applied, then that particular needle size is too large and such a needle may infiltrate in the course of cannulation. One should use a needle size that is equal to or smaller than the vein (without the tourniquet). The smallest needle available, usually a 17G, typically is used for initial cannulation attempts. It is important to keep in mind that blood flow delivered by a 17G needle is limited.

Prepump arterial monitoring is recommended to ensure that blood pump speed does not exceed a flow that the needle can easily provide. Prepump arterial pressure should not exceed -250 mm Hg. Based on performance of the fistula using a 17G needle, the decision to increase the needle size for subsequent cannulation can be made. A 17G needle ordinarily will not deliver more than 250 mL/min blood flow, and a 16G needle will not

deliver a blood flow rate greater than 350 mL/min. Progression from the 17G to larger needles depends on adequate vessel size and access flow.

E. **Initial cannulation procedure**

1. Apply a tourniquet to the access arm.
2. Disinfect the access site per unit protocol.
3. Attach a **10-mL syringe filled with 8 mL of normal saline solution** to the needle, but do not prime the needle until immediately before the cannulation.
4. Grasp the needle by its butterfly wings and **prime the needle with normal saline** until all the air has been purged. Clamp the needle closed. Remove the protective cap and immediately proceed with the cannulation.
5. Carefully cannulate the fistula using a 25° insertion angle. When **blood flashback** is observed (the needle may need to be unclamped to see the blood flashback), flatten the angle of the needle, parallel to the skin, and advance it slowly into the fistula lumen.
6. When the needle is in the vessel, remove the tourniquet and tape the needle securely per unit protocol. If blood flashback is visible, **aspirate back 1–5 mL** with the 10-mL syringe.
7. **Flush the needle** with the normal saline solution and clamp. The syringe must aspirate and flush with ease. Monitor for signs or symptoms of infiltration. Patients usually experience immediate sharp pain upon infiltration of saline or blood into the tissues.
8. Repeat steps 1–7 for the second needle unless blood return via a venous catheter is planned (see what follows).

F. **One needle technique with return using a venous catheter.** In patients who still have a venous catheter in place, one does not need to necessarily begin dialysis with the new fistula using two needles. The risk of infiltration is much higher with the blood return (dialyzer outflow) needle. For the first 2 or 3 treatments, the blood can be returned via the venous catheter. Next, dialysis can be done using two needles in the fistula, and only after several treatments have been successful is the venous catheter removed.

X. **ARTERIOVENOUS GRAFTS.** As described at the outset of this chapter, AV grafts are less desirable than AV fistulas, primarily because of their lower long-term patency rates and greater need for endovascular interventions to maintain patency. AV grafts do have some advantages, including a large surface area for needle placement, easy cannulation, short maturation time, and easy surgical handling characteristics.

Most AV grafts placed in the United States are composed of expanded PTFE. The choice of synthetic or biologic material should be based on the surgeon's preference and experience. Use of cryopreserved vein grafts, especially those placed in the thigh, is associated with a higher risk of infection. Short grafts have no advantage over long grafts in terms of patency and longevity. Tapered grafts, externally supported grafts, or elastic grafts do not provide results better than standard PTFE grafts. Modification of the distal anastomosis of PTFE grafts with a venous cuff may decrease venous stenosis and increase graft patency. Newer heparin-bonded materials in grafts are being used, but they do not appear to have any long-term advantages.

A. **Potential AV graft locations**

1. **Common locations.** Grafts may be placed in straight, looped, or curved configurations

(Fig. 6.4). The common initial sites for AV graft placement are a straight graft from the radial artery at the wrist to the basilic vein; a loop graft in the forearm from the brachial artery to the basilic vein (Fig. 6.5); or an upper arm graft from brachial artery to axillary vein (Fig. 6.6). Patient-specific features and projected time on dialysis help determine location; a distal graft in the nondominant arm is generally preferred initially. While this approach preserves proximal arm sites for future placement of a fistula, distal grafts are associated with more frequent episodes of thrombosis. A distal graft (e.g., straight forearm graft from radial artery to an antecubital fossa vein) can sometimes be used to mature a proximal downstream vein for future AV fistula construction.

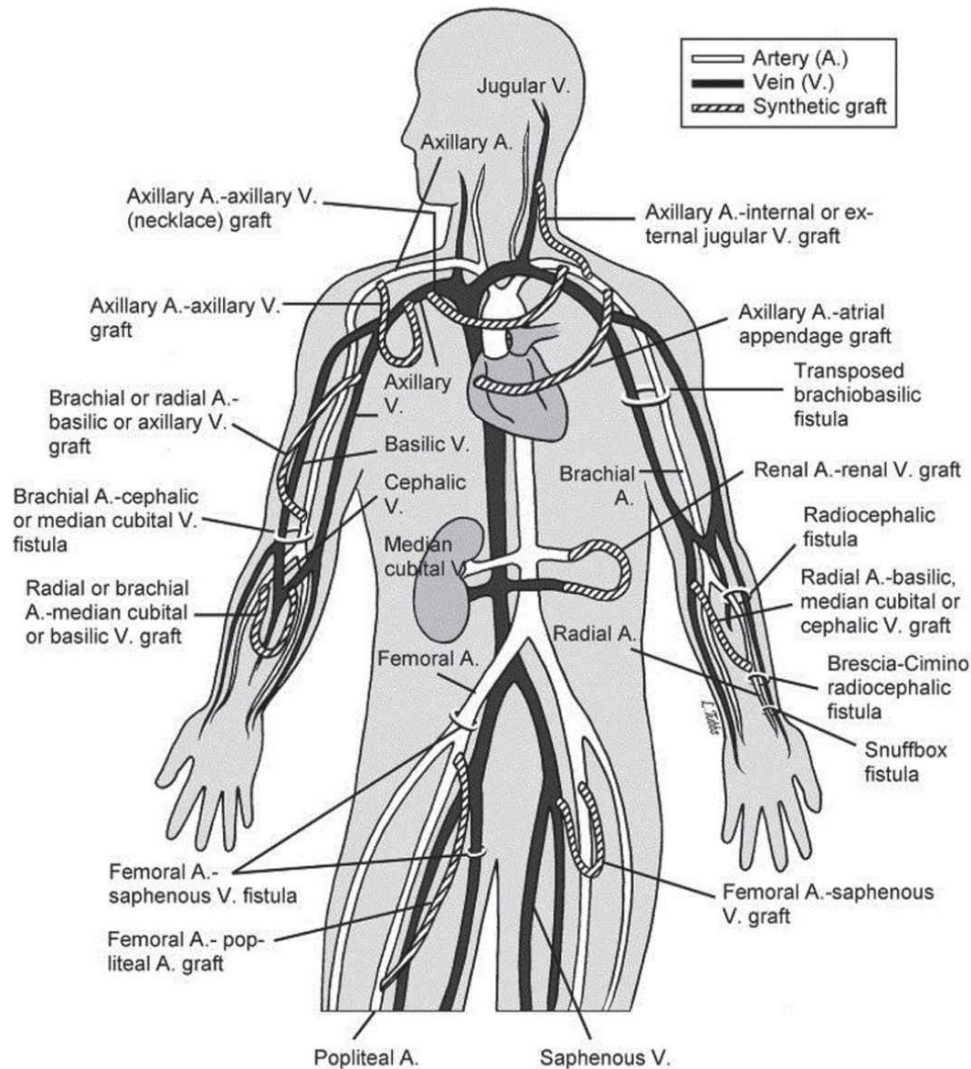

FIGURE 6.4 Various configuration and sites for AV graft placement. (Reprinted with permission from Paulson WD, Ram SJ, Zibari GB. Vascular access: anatomy, examination, management. *Semin Nephrol.* 2002;22:183-194.)

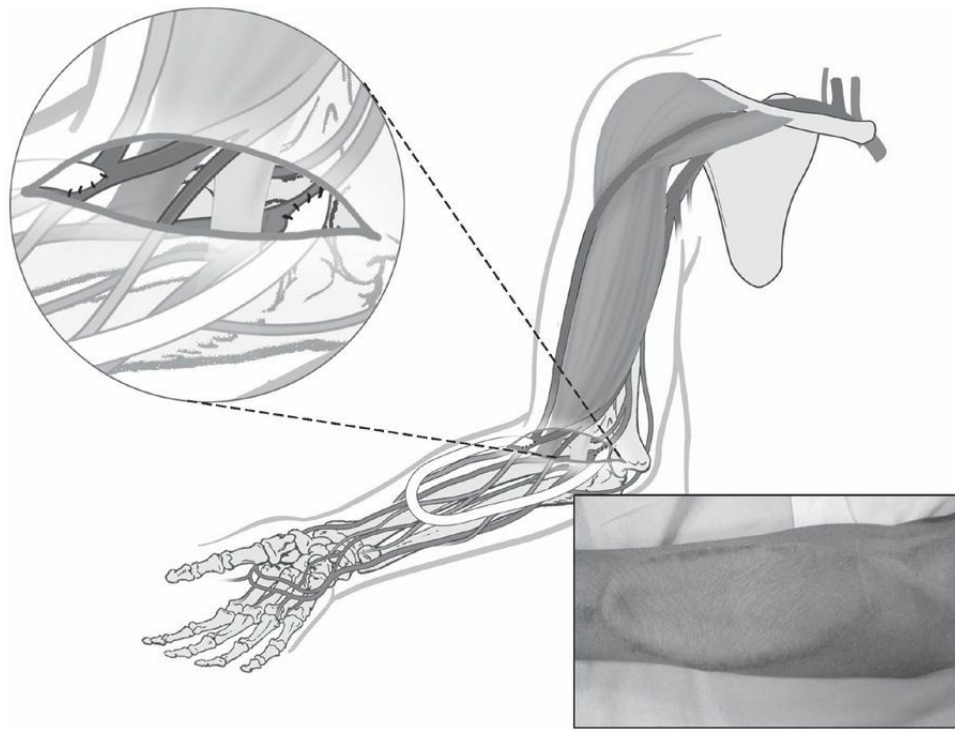

FIGURE 6.5 Forearm loop AV graft. (Reprinted with permission from Atlas of Dialysis Vascular Access—<http://www.fistulafirst.org>.)

2. **Uncommon locations.** The axillary artery can be used as the source of a loop graft in the upper extremity. The graft can extend from the arm to the internal jugular vein to bypass ipsilateral subclavian vein stenosis. An AV graft can also be placed in the thigh, but then there is a higher associated complication rate. A chest wall axilloaxillary (necklace) graft is another option when other sites have been exhausted. Multiple other sites including an axillary artery-to-femoral vein graft can be used, depending on the individual patient and the experience and skills of the surgeon.

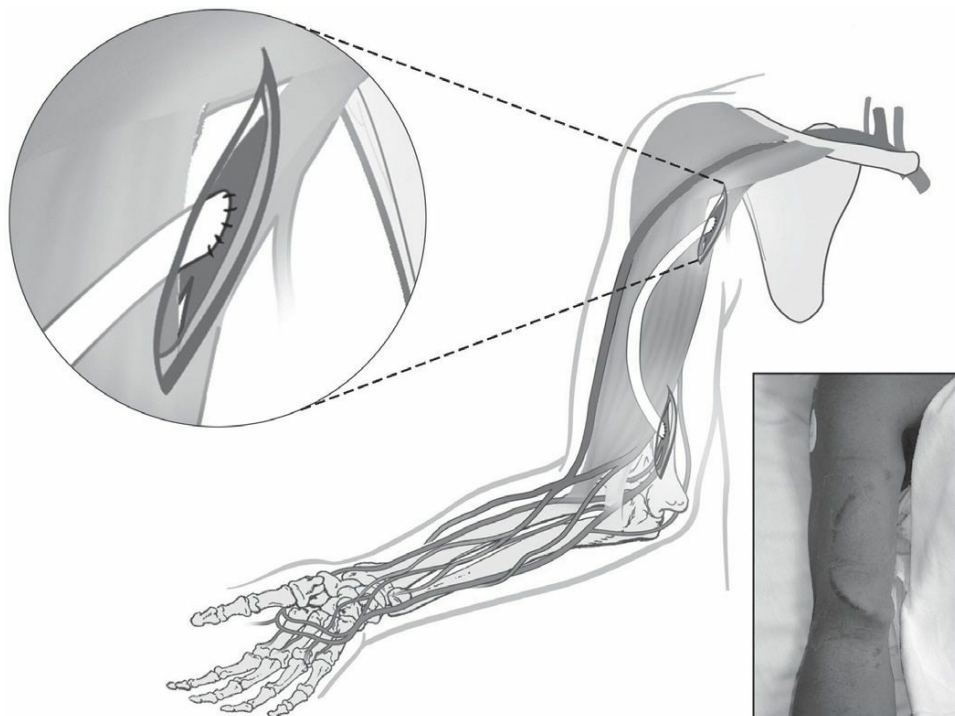

FIGURE 6.6 Upper arm AV graft. (Reprinted with permission from Atlas of Dialysis Vascular

- B. **Surgical placement.** Prophylactic antibiotics are often administered just prior to the operation. The anastomosis should be made between the end of the graft and the side of the vein or artery to minimize interference with blood flow through the native vessels. Some studies suggest that nonpenetrating clips may be superior to conventional sutures by avoiding endothelial penetration. A clip should be placed at the arterial and venous anastomoses for identification during subsequent angiography.
- C. **Postoperative care.** This is similar to care after creation of an AV fistula. The extremity is kept elevated for several days. Graft function is checked regularly by assessing for venous pulsation, thrill, and bruit. There is no point in doing arm exercises to hasten maturation.
- D. **Maturation.** A PTFE graft should not be cannulated for at least 2 weeks after placement and is considered mature when edema and erythema have resolved and the graft course is easily palpable. Adhesion between the graft and the subcutaneous tunnel to prevent hematoma formation requires at least 2–3 weeks. Cannulation of a graft that cannot be easily palpated or in an edematous site invites inaccurate needle insertion, leading to hematoma formation or frank laceration. Patients with persistent arm edema that fails to respond to arm elevation should have an imaging study to evaluate the status of their central veins.
 - 1. **Early-use grafts.** Several early-use grafts have been introduced for immediate postoperative access to avoid risks associated with central venous catheters. The performance of a multilayered, self-sealing polyurethane graft is comparable to that of a conventional PTFE graft and allows for early access. Its placement requires more skill than placement of a conventional PTFE graft because the risk of graft kinking and twisting within the tunnel is somewhat higher. Composite grafts should not be cannulated for at least 24 hours after placement, and not until swelling around the surgical wound has resolved and the graft can be easily palpated. A self-sealing graft composed of heparin-bonded polycarbonate that is immediately available for puncture has been developed.
 - 2. **Autologous tissue grafts.** Preliminary experience with autologous, tissue engineered vascular grafts has been encouraging (Wystrychowski, 2013). However, it is not known to what extent use of such grafts will prevent long-term complications and how resistant they will be to leakage under repeated punctures for regular dialysis.

XI. PHYSICAL EXAMINATION OF AV FISTULAS AND GRAFTS. Physical examination is a noninvasive and cost-effective test that is emerging as an important tool in the evaluation of an AV access. Multiple studies have demonstrated that physical examination can accurately detect and localize stenotic lesions in a great majority of patients with an AV access. Physical examination can be very helpful not only in the postoperative monitoring of a new graft or fistula but also in the evaluation of access dysfunction. The latter topic is discussed in more detail in Chapter 8.

- A. **Inspection.** Examination should not be limited to the site of the AV access but should also include the remaining part of arm, shoulder, breast, neck, and face. Presence of swelling in any of these areas should be recorded and raise the suspicion of a downstream stenosis.

The presence of collateral veins should also indicate downstream stenosis. Any scars on the chest wall should be carefully examined for evidence of previous catheter insertion sites. The presence of face, neck, or breast swelling usually is due to central venous stenosis.

B. **Palpation and auscultation**

1. **Pulse.** Normally, an AV access demonstrates a soft pulse that is easily compressed by the application of gentle pressure. In the presence of a downstream stenosis (outflow stenosis), the pulse becomes augmented (hyperpulsatile, water-hammer pulse). Often, a water-hammer pulse can be seen as strong pulsation on inspection. The clinical history that goes with this scenario is frequently the presence of prolonged bleeding after removal of the access needles. In contrast to the water-hammer pulse, a feeble pulse (flat access, hypopulsation) indicates an upstream stenosis. The clinical history that goes with a feeble pulse often includes inability to aspirate blood from the arterial needle (needle pulling negative pressure). The access is usually “plump” upstream to a stenosis and “flat” downstream from a stenosis.
2. **Thrill.** The thrill of an AV access is a “buzz” that can be felt by the examining fingers. The thrill can be continuous or discontinuous. Normally, there is a continuous nature to the thrill except at the arterial anastomosis where the thrill normally is discontinuous. The quality of the thrill should be evaluated from the anastomosis all the way to the chest wall (many a times cephalic arch stenosis gives a discontinuous thrill at the cephalic arch area in the anterior part of the shoulder). In the presence of a stenosis, the thrill becomes discontinuous; frequently, a systolic thrill can be felt immediately downstream from a stenosis.
3. **Auscultation.** Auscultation can be performed to assess the quality of the bruit in the AV access. As with palpation for a thrill, auscultation for a bruit allows for the detection and localization of a stenosis by presence of a continuous versus discontinuous bruit.

C. **Pulse augmentation and arm elevation tests.** There are two additional tests that can be used to quickly examine an AV access. The **pulse augmentation test** evaluates the **inflow** segment while the **arm elevation test** assesses the **outflow** tract.

1. **Pulse augmentation.** This is performed by a complete occlusion of the access several centimeters beyond the arterial anastomosis and evaluation of the strength of the pulse. The test is considered normal when the portion of fistula upstream from the occluding finger demonstrates an augmentation of pulse. With an AV fistula, the presence of side branches can be detected using the pulse augmentation test. Upon occlusion of the outflow of an AV access by the examining finger, two things should normally occur. (1) The thrill should disappear. (2) The part of the access upstream to the occluding finger should become hyperpulsatile (augment). If the thrill persists after the occlusion of the access, the presence of an accessory outflow pathway should be suspected. In this case, the access pulse does not augment as the anticipated increase in pressure is dissipated by the presence of the accessory pathway. One can often pinpoint the location of the side branch by moving the occluding finger toward the anastomosis of the fistula. When the thrill disappears and the access augments, the examiner’s occluding finger will have just passed the site of the side branch. Moving the finger away from the

anastomosis should bring the thrill back. This maneuver confirms the location of the side branch.

2. **Arm elevation test.** This is performed by elevating the extremity and examining the normal collapse of an AV fistula. The test is considered abnormal when the fistula remains plump after arm elevation and fails to collapse. This indicates the presence of downstream stenosis.

XII. GENERAL ISSUES RELATING TO CANNULATION OF EITHER AV FISTULAS OR GRAFTS

- A. **Skin preparation.** An aseptic technique must be used for all cannulation procedures.
- B. **Anesthesia.** In pain-sensitive patients, a topical anesthetic cream can be applied to the skin about 30 minutes prior to puncture, but this is rarely required. Most patients, especially those with new accesses, require subcutaneously injected lidocaine prior to needle cannulation. Injected anesthetic is especially helpful when manipulation of the needle is anticipated. Patients with established needle tracts often tolerate direct puncture without anesthesia and some find the anesthetic injection more painful than a direct stick.
- C. **Use of tourniquets for AV fistulas.** A tourniquet or blood pressure cuff should be used to enlarge and stabilize the vein for easier cannulation of AV fistulas. A tourniquet should not be used during the dialysis treatment; a fistula that works only when a tourniquet is in place is still underdeveloped, usually because of inflow stenosis, and such a fistula needs more time or reevaluation by the vascular access team prior to use.

If a tourniquet is not required for cannulation and the fistula does not soften with arm elevation, a downstream (outflow) stenosis may be present and should be searched for using imaging studies.

- D. **Needle size.** As noted above, during the initial use of a permanent vascular access, especially a fistula, some nephrologists recommend the use of small (16G to 17G) needles and low blood flow rates. In mature accesses, larger (15G) needles are needed to support blood flow rates (>350 mL/min) required for high-efficiency dialysis.
 - E. **Needle position, spacing, and orientation.** Two needles are placed into the dilated vein(s) of the fistula or into the graft. The needle leading to the dialyzer blood inlet is always placed in the more upstream segment but at least 3 cm away from the arterial anastomotic site. This upstream or “arterial” needle may point either upstream or downstream. Pointing the upstream needle in a downstream direction is popular in some countries, the rationale being that the “flap” left behind when the needle is withdrawn tends to close more naturally with the flow of blood. However, there is no controlled evidence to suggest that this is the case. The downstream (outlet or “venous”) needle should be inserted pointing downstream, approximately 5 cm downstream to the upstream (arterial) needle (to minimize recirculation). One study found that recirculation does not occur, even with needles spaced as closely as 2.5 cm from one another (Rothera, 2011). Some caregivers rotate each needle 180 degrees along the needle axis after insertion to prevent potential injury to the deep wall of the vessel by the needle point. This issue has not been systematically studied but generally is not recommended.
1. **Risk of inflow/outflow needle reversal.** Special care must be taken when cannulating forearm loop grafts. In more than 80% of such grafts, the arterial limb will be medial (ulnar),

but in the remainder the arterial limb may lie on the radial side of the forearm. Reversal of needle placement may occur unless the dialysis clinic staff knows that blood in this particular graft flows in the opposite-to-usual direction. Reverse needle placement substantially increases the amount of recirculation (to >20%) and can result in inadequate delivery of dialysis. This happens more commonly than one would expect, as patients may have access surgery at another center and a diagram of the inserted access might not be readily available. When in doubt, a careful physical examination with transient occlusion of the access and palpation on either side of the occluding finger for pulsations will reveal the direction of blood flow in most cases. For reference, a “road map” diagram of the access from the surgeon who placed the access is very helpful.

- F. **Repeated punctures: Needle rotation.** The manner in which needles are inserted affects the long-term patency and survival of accesses, particularly of AV fistulas. The “ladder” or rotational approach uses the entire length of the access without localizing needle sticks to any two areas. Grouping needle sticks in one or two specific areas can weaken the wall of a fistula, producing an aneurysm.
- G. **Buttonhole cannulation tips.** In AV fistulas, one technique of placing access needles is the so-called “buttonhole” method. The AV fistula is always punctured through a limited number of sites, the use of which may be rotated. The needle must be placed precisely through the same needle tract used previously. After the buttonhole has been developed using sharp needles, special “dulled” needles are used to minimize laceration of the buttonhole tract. Initial enthusiasm for the buttonhole approach has been tempered with suggestions that its use may lead to increased infectious complications and may do little to prolong AV fistula longevity (MacRae, 2014; Muir, 2014). The degree of success with the buttonhole approach may be highly technique dependent. There is no published experience with the buttonhole method in AV grafts, and it should not be tried in AV grafts without further study.

Buttonhole cannulation requires strict adherence to proper infection control measures as well as technique to prevent serious infection and technique-related complications (Dinwiddie, 2013).

1. Employ proper buttonhole cannulation procedure steps (skin prep, proper scab removal, re-prep of the skin, and proper use of blunt needles).
 2. Use the needle wings to help guide the needle gently into the skin and vessel or conduit—excessive pressure prevents feedback to the cannulator’s fingers to feel resistance.
 3. Always cannulate the buttonhole under consistent conditions; if a tourniquet was used to establish the buttonhole, it should be used consistently, as otherwise the tissues in the buttonhole tract may not align.
 4. Consider the patient as a self-cannulation candidate. Benefits can include patient empowerment, less pain, and ease of cannulation, as the patient has to master cannulation of only his or her own specific access.
- H. **Preventing and dealing with infiltration.** Infiltrations with cannulation can occur before dialysis, during dialysis with the blood pump running, or after dialysis in the course of needle removal. One should monitor closely for signs and symptoms of infiltration. A quick

response to a needle infiltration can help minimize damage to the access.

1. If the infiltration occurs after the administration of heparin, care must be taken to properly clot the needle tract and not the fistula. In some cases, the decision to leave the needle in place and cannulate another site may be appropriate. The immediate application of ice can help decrease pain and the size of the infiltration and may decrease bleeding time.
 2. Use caution when taping needles. Avoid lifting up on the needle after it is in the vein. An improper needle flip or taping procedure can cause an infiltration.
 3. If the fistula is infiltrated, it is best to rest the fistula for at least one treatment. If this is not possible, the next cannulation should be downstream of the site of the infiltration. If the patient still has a central venous catheter in place, one can restart use of the fistula with one needle, returning blood via the venous catheter, and later advance to two needles, a larger needle size, and greater blood flow rates as the access allows.
 4. Proper needle removal prevents postdialysis infiltrations. Prior to removing the needle, apply the gauze dressing over the needle site, but do not yet apply pressure. Next, carefully remove the needle at approximately the same angle as it was inserted. This prevents dragging the needle across the patient's skin. Using too steep of an angle during needle removal may cause the needle's cutting edge to puncture the vein wall.
 5. Do not apply pressure to the puncture site until the needle has been completely removed.
 6. Notify the nephrologist as soon as a cannulation injury has occurred. In some cases, fistula rest is adequate. In others, an intervention may be required.
- I. **Hemostasis postdialysis.** Following needle removal, direct pressure over the site, usually with the tip of one or two fingers pushed firmly but not so hard as to occlude flow, is the best method for achieving hemostasis. One must prevent hematoma formation at the access site while controlling bleeding at the skin exit site. Pressure must be held for at least 10 minutes before checking the needle site for bleeding. Adhesive bandages should not be applied until complete hemostasis has been achieved.

Prolonged bleeding (>20 minutes) may indicate increased intra-access pressure due to an unsuspected outflow stenosis. Bleeding also is common in patients receiving therapeutic doses of anticoagulants such as warfarin. Another cause of bleeding is heparin escape from a venous catheter lock in patients who are being transitioned from a venous catheter to an AV fistula, where the venous catheter is being used to return blood during initial fistula test use.

References and Suggested Readings

- Agarwal AK. Central vein stenosis: current concepts. *Adv Chronic Kidney Dis*. 2009;16:360–370.
- Agarwal R, McDougal G. Buzz in the axilla: a new physical sign in hemodialysis forearm graft evaluation. *Am J Kidney Dis*. 2001;38:853–857.
- Asif A, et al. Early arteriovenous fistula failure: a logical proposal for when and how to intervene. *Clin J Am Soc Nephrol*. 2006;1:332–339.
- Asif A, et al. Vascular mapping techniques: advantages and disadvantages. *J Nephrol*. 2007;20:299–

- Asif A, et al. Accuracy of physical examination in the detection of arteriovenous graft stenosis. *Semin Dial.* 2008;21:85–88.
- Beathard GA. An algorithm for the physical examination of early fistula failure. *Semin Dial.* 2005;18:331–335.
- Bharat A, Jaenicke M, and Shenoy S. A novel technique of vascular anastomosis to prevent juxta-anastomotic stenosis following arteriovenous fistula creation. *J Vasc Surg.* 2012;55:274–80.
- Campos PR, et al. Stenosis in hemodialysis arteriovenous fistula: evaluation and treatment. *Hemodial Int.* 2006;10:152–161.
- Campos PR, et al. Accuracy of physical examination and intra-access pressure in the detection of stenosis in hemodialysis arteriovenous fistula. *Semin Dial.* 2008;21:269–273.
- Caroli A, et al; for the ARCH project Consortium. Validation of a patient-specific hemodynamic computational model for surgical planning of vascular access in hemodialysis patients. *Kidney Int.* 2013;84:1237–1245.
- Chemla ES, et al. Complex bypasses and fistulas for difficult hemodialysis access: a prospective, single-center experience. *Semin Dial.* 2006;19:246–250.
- Coskun I, et al. Hemodynamic effects of left upper extremity arteriovenous fistula on ipsilateral internal mammary coronary artery bypass graft. *Thorac Cardiovasc Surg.* 2013;61:663–667.
- Crowther MA, et al. Low-intensity warfarin is ineffective for prevention of PTFE graft failure in patients on hemodialysis: a randomized controlled trial. *Clin J Am Soc Nephrol.* 2002;13:2331–2337.
- Dember LM, et al; Dialysis Access Consortium (DAC) Study Group. Effect of clopidogrel on early failure of arteriovenous fistulas for hemodialysis: a randomized controlled trial. *JAMA.* 2008;299:2164–2171.
- Dinwiddie LC, et al. What nephrologists need to know about vascular access cannulation. *Semin Dial.* 2013;26:315–322.
- Drawz PE, et al. A simple tool to predict end-stage renal disease within 1 year in elderly adults with advanced chronic kidney disease. *J Am Geriatr Soc.* 2013;61:762–768.
- Feldman L, et al. Effect of arteriovenous hemodialysis shunt location on cardiac events in patients having coronary artery bypass graft using an internal thoracic artery. *J Am Soc Nephrol.* 2013;24:214A (abstract).
- Gradzki R, et al. Use of ACE inhibitors is associated with prolonged survival of arteriovenous grafts. *Am J Kidney Dis.* 2001;38:1240–1244.
- Hoggard J, et al. ASDIN guidelines for venous access in patients with chronic kidney disease: a position statement from the American Society of Diagnostic and Interventional Nephrology Clinical Practice Committee and the Association for Vascular Access. *Semin Dial.* 2008;21:186–191.
- Huijbregts HJ, Blankestijn PJ. Dialysis access—guidelines for current practice. *Eur J Vasc Endovasc Surg.* 2006;31:284–287.
- Jaberi A, et al. Arteriovenous fistulas for hemodialysis: application of high-frequency US to assess vein wall morphology for cannulation readiness. *Radiology.* 2011;216:616–624.
- Kaufman JS, et al. Randomized controlled trial of clopidogrel plus aspirin to prevent hemodialysis access graft thrombosis. *J Am Soc Nephrol.* 2003;14:2313–2321.

- Konner K. A primer on the AV fistula—Achilles' heel, but also Cinderella of haemodialysis. *Nephrol Dial Transplant*. 1999;14:2094–2098.
- Lin CC, et al. Effect of far infrared therapy on arteriovenous fistula maturation: an open-label randomized controlled trial. *Am J Kidney Dis*. 2013;62:304–311.
- Lok CE, Davidson I. Optimal choice for dialysis access for chronic kidney disease patients: developing a life plan for dialysis access. *Semin Nephrol*. 2012;32:530–537.
- Lok CE, et al. Cumulative patency of cotemporary fistulas versus grafts (2000–2010). *Clin J Am Soc Nephrol*. 2013;8:810–818.
- MacRae JM, et al. Arteriovenous fistula survival and needling technique: long-term results from a randomized buttonhole trial. *Am J Kidney Dis*. 2014;63:636–642.
- Malovrh M. Native arteriovenous fistula: preoperative evaluation. *Am J Kidney Dis*. 2002;39:1218–1225.
- Maya ID, et al. Vascular access stenosis: comparison of arteriovenous grafts and fistulas. *Am J Kidney Dis*. 2004;44:859–865.
- Moist LM, et al. Optimal hemodialysis vascular access in the elderly patient. *Semin Dial*. 2012;25:640–648.
- Moist LM, et al. Education in vascular access. *Semin Dial*. 2013;26:148–153.
- Muir CA, et al. Buttonhole cannulation and clinical outcomes in a home hemodialysis cohort and systematic review. *Clin J Am Soc Nephrol*. 2014;9:110–119.
- Murea M, et al. Risk of catheter-related bloodstream infection in elderly patients on hemodialysis. *Clin J Am Soc Nephrol*. 2014;9:764–770.
- National Kidney Foundation. 2006 NKF-K/DOQI clinical practice guidelines for vascular access: update 2006. *Am J Kidney Dis*. 2006;48(suppl 1):S177–S277.
- Ohira S, Kon T, Imura T. Evaluation of primary failure in native AV-fistulae (early fistula failure). *Hemodial Int*. 2006;10:173–179.
- Okada S, Shenoy S. Arteriovenous access for hemodialysis: preoperative assessment and planning. *J Vasc Access*. 2014;15(suppl 7):1–5.
- Ortega T, et al. The timely construction of arteriovenous fistulas: a key to reducing morbidity and mortality and to improving cost management. *Nephrol Dial Transplant*. 2005;20:598–603.
- Palmes D, et al. Perforating vein fistula is superior to forearm fistula in elderly haemodialysis patients with diabetes and arterial hypertension. *Nephrol Dial Transplant*. 2011;26:3309–3314.
- Paul BZS, Feeny CM. Combining the modified Allen's test and pulse oximetry for evaluating ulnar collateral circulation to the hand for radial artery catheterization of the ED patient. *Calif J Emerg Med*. 2003;4:89-91.
- Pirozzi N, et al. Microsurgery and preventive haemostasis for autogenous radial–cephalic direct wrist access in adult patients with radial artery internal diameter below 1.6 mm. *Nephrol Dial Transplant*. 2010;25:520–525.
- Rothera C, et al. The influence of between-needle cannulation distance on the efficacy of hemodialysis treatments. *Hemodial Int*. 2011;15:546–552.
- Saad TF, et al. Cardiovascular implantable device leads in CKD and ESRD patients: review and recommendations for practice. *Semin Dial*. 2013;26:114–123.
- Saucy F, et al. Is intra-operative blood flow predictive for early failure of radiocephalic arteriovenous fistula? *Nephrol Dial Transplant*. 2010;25:862–867.

- Shenoy S. Surgical anatomy of upper arm: what is needed for AVF planning. *J Vasc Access* 2009;10:223–232.
- Tangri N, et al. A predictive model for progression of chronic kidney disease to kidney failure. *JAMA*. 2011;305:1553–1559.
- Tangri N, et al. Validation of the kidney failure risk equation in an International Consortium [abstract SA-OR055]. *J Am Soc Nephrol*. 2013;24:84A.
- Vachharajani TJ. Diagnosis of arteriovenous fistula dysfunction. *Semin Dial*. 2012;25:445–450.
- Vachharajani TJ, et al. Re-evaluating the fistula first initiative in octogenarians on hemodialysis. *Clin J Am Soc Nephrol*. 2011;6:1663–1667.
- Vaux E. Effect of buttonhole cannulation with a polycarbonate peg on in-center hemodialysis fistula outcomes: a randomized controlled trial. *Am J Kidney Dis*. 2013;62:81–88.
- Wystrychowski W, et al. First human use of an allogeneic tissue-engineered vascular graft for hemodialysis access. *J Vasc Surg*. 2014, in press.
- Xue JL, et al. The association of initial hemodialysis access type with mortality outcomes in elderly Medicare ESRD patients. *Am J Kidney Dis*. 2003;42:1013–1019.

Web References

- American Nephrology Nurses' Association "Save the Vein" project. <http://www.annanurse.org/resources/save-the-vein-campaign>.
- American Society of Diagnostic and Interventional Radiology. <http://www.asdin.org/>.
- Atlas of Dialysis Vascular Access. <http://www.theisn.org/hemodialysis/education-by-topic>.
- Fistula First initiative: <http://www.fistulafirst.org>.
- Physical examination of arteriovenous fistula. <http://www.youtube.com/watch?v=m1-C61AOY3Q>.



Venous Catheter Access: The Basics

Michael Allon and Arif Asif

- I. **OVERVIEW.** Patients being dialyzed with venous catheters do not do as well as those using an arteriovenous access. Catheter patients develop infections more often, they have higher levels of inflammatory markers such as C-reactive protein, and they die more frequently. It is unclear if these associative risks reflect a different patient population receiving catheters, some risk factor that occurs when AV accesses fail and a catheter must be placed, or if they are due completely to some property of catheter use per se. Probably all three are important. Survival rates for catheters are about 60% at 6 months and 40% at 1 year if revisions are included. Inadequate blood flow through venous catheters remains a significant problem. Nominal flow >400 mL/min (actual flow 350 mL/min) can rarely be obtained, and usually flow is limited to a range closer to 300 mL/min. This limits use of venous catheters in larger patients and results in a lower than average urea reduction ratio (URR) or fractional urea clearance (Kt/V).

In the chronic setting, venous catheters are utilized as a long-term vascular access for patients in whom an AV access cannot be readily created. Such patients include small children, some diabetic patients with severe vascular disease, patients who are morbidly obese, and patients who have undergone multiple AV access insertions and in whom additional sites for AV access insertion are not available. Additional indications include patients with cardiomyopathy unable to sustain adequate blood pressures or access flows. Whereas catheters were initially favored for more frequent dialysis, there has been good recent experience with nocturnal dialysis and short daily dialysis using AV fistulas or grafts. There has been renewed discussion about the potential acceptability of venous catheter access for chronic dialysis in some elderly patients, especially those with comorbidities and limited expected life span (Drew and Lok, 2014). Infection rates with venous catheters in elderly patients (>75 years) are relatively low, one-third that in younger patients (Murea, 2014). Adherence to hand washing and catheter-care protocols such as those suggested by the U.S. Centers for Disease control has resulted in marked overall reduction of dialysis catheter infection rates (Patel, 2013).

II. CATHETER TYPES AND DESIGN

- A. **Cuffed versus uncuffed.** Use of an uncuffed catheter for periods of time beyond several weeks results in a relatively high rate of infection and is not recommended. Dacron or felt cuffs bonded to the catheter reduce the incidence of line-related infection and of catheter migration and must be used whenever a longer-term use of the catheter is anticipated, or

when it is anticipated that a patient will be discharged from the hospital with a catheter remaining in place.

- B. **Design issues.** Dual-lumen venous catheters are available in a “double-D” configuration or where the two lumens are in some related, side-by-side configuration. Coaxial catheters are now less frequently used. A side-by-side port design permits the intravenous portion of the catheter to be split into two parts close to the termination point. This results in a softer, more pliable catheter end, a greater separation of inlet and outlet ports, and perhaps a lower recirculation rate. The cuffed Tesio catheter system (used primarily for chronic dialysis) consists of two completely separate catheters, each made of soft silicone material, one for inflow and one for outflow.
- C. **Antiseptic impregnation.** Some dialysis catheters or their cuffs are impregnated with antiseptic or silver-based coatings in an attempt to inhibit bacterial growth. At present there are no large studies that demonstrate improved outcomes with such catheters.

III. ACUTE DIALYSIS

- A. **Indications.** Venous catheters are commonly used for acute angioaccess in the following patients: (a) those with acute renal failure; (b) those requiring hemodialysis or hemoperfusion for overdose or intoxication; (c) those with late-stage chronic kidney disease needing urgent hemodialysis but without available mature access; (d) those on maintenance hemodialysis who have lost effective use of their permanent access and require temporary access until permanent access function can be reestablished; (e) patients requiring plasmapheresis; (f) peritoneal dialysis patients whose abdomens are being rested prior to new peritoneal catheter placement (usually for severe peritonitis that required peritoneal dialysis catheter removal); and (g) transplant recipients needing temporary hemodialysis during severe rejection episodes. The renascent interest in urgent start peritoneal dialysis, discussed in Chapter 24, and earlier referral of patients with CKD for access placement should lower the need for urgent placement of central venous catheters for hemodialysis.
- B. **Insertion location.** Available sites include the right and left internal jugular vein, the femoral veins, and the subclavian veins. One order of preference for these various sites is shown in Table 7.1. The optimal insertion site is the **right internal jugular vein** because the venous pathway to the right atrium is relatively short and straight. The subclavian site should generally be avoided because it is associated with a higher incidence of insertion-related complications (pneumothorax, hemothorax, subclavian artery perforation, brachial plexus injury) and a high incidence (up to 40%) of central venous stenosis. Use of the **left internal jugular vein** for acute dialysis is not optimal, as this represents a relatively long and twisty pathway to the right atrium; if subsequent chronic dialysis is needed, ideally one would like to leave the upper extremity central venous vessels alone to limit the rate of future stenosis. The **femoral vein** approach has several potential advantages. Placement tends to be simpler, especially for inexperienced operators. There is no risk of pneumothorax, hemothorax, or brachial plexus injury, although femoral arterial puncture and retroperitoneal bleed can occur. Originally, it was thought that the femoral approach had a higher risk of infection, but recent experience from the Cathedia Study Group found

comparable rates of infection and time to catheter tip colonization (14 days) with femoral and internal jugular catheters (Dugué, 2012). The femoral approach is useful for performing the initial hemodialysis treatment in patients who present with acute pulmonary edema because the patient's head and chest can remain elevated during insertion. The infection risk with femoral catheters is increased in obese patients ($\text{BMI} > 28 \text{ kg/m}^2$), although the extent of this risk probably depends on the distribution of body fat. When femoral catheters are used, the length must be sufficient (usually at least 20 cm) so that the tip is in the inferior vena cava to permit better flow and to minimize recirculation. Another finding from the Cathedia Study was that delivered URR and Kt/V were similar with femoral and jugular catheters (Dugué, 2012). The European Best Practices Group does not agree with the order of preference of insertion sites listed in Table 7.1, and gives second preference to the left internal jugular vein, and recommends that femoral catheters be discouraged (Vanholder, 2010).

TABLE

7.1

Selected Factors Favoring Different Temporary (Nontunneled) Hemodialysis Catheter Insertion Sites

1. Right internal jugular

- Critically ill and bed-bound with body mass index >28
- Postoperative aortic aneurysm repair
- Ambulatory patient/mobility required for rehabilitation

2. Femoral

- Critically ill and bed-bound with body mass index <24
- Tracheostomy present or planned in near-term
- Need for long-term hemodialysis access present, highly likely or planned
- Emergency dialysis required plus inexperienced operator and/or no access to ultrasound

3. Left internal jugular

- Contraindications to right internal jugular and femoral sites

4. Subclavian

- Contraindications to internal jugular
- Right side to be used preferentially

Source: Reprinted by permission from Macmillan Publishers Ltd: Clark EG, Barsuk JH. Temporary hemodialysis catheters: recent advances. *Kidney Int.* 2014. doi:10.1038/ki.2014.162.

- C. **Uncuffed versus cuffed catheter use.** The risk of infection of uncuffed catheters increases markedly after the first week. For this reason, the KDOQI 2006 vascular access guidelines recommend use of a cuffed catheter if the anticipated need for dialysis is longer than 1 week. They also recommend that femoral catheters in bed-bound patients not be left in place longer than 5 days. These recommendations, especially with regard to femoral catheters, may be a bit too stringent given the results of the Cathedia Study (Dugué, 2012), where median time to catheter tip colonization was 14 days. Once the likelihood of the

need for prolonged dialysis is established, an uncuffed internal jugular catheter can be replaced with a cuffed catheter. In cases where a prolonged need for dialysis is likely at the outset, a cuffed catheter can be inserted initially, in the right internal jugular vein position if possible. Recently some success has been claimed using cuffed tunneled femoral catheters (Hingwala, 2014). This has the advantage of locating the exit site away from overhanging skin folds, and easy removal, as long as removal is done within several weeks of insertion. Placing a cuffed femoral catheter allows time for more definitive access site placement, whether it be for peritoneal dialysis or hemodialysis.

- D. **Anatomic variation and use of real-time ultrasound guidance.** The central veins of the neck exhibit anatomic variability (Fig. 7.1), and occasionally one of them may be absent. Atypical or ectatic carotid arteries are also a problem. With the use of ultrasound guidance, the rate of successful internal jugular puncture on first attempt increases markedly and the rate of carotid artery punctures and hematoma is greatly reduced (Rabindranath, 2011). In the femoral approach, the femoral vein often is behind the artery, and this overlap worsens as one proceeds down from the inguinal ligament (Beaudoin, 2011). Here, too, the use of ultrasound helps reduce complications (Clark and Barsuk, 2014).

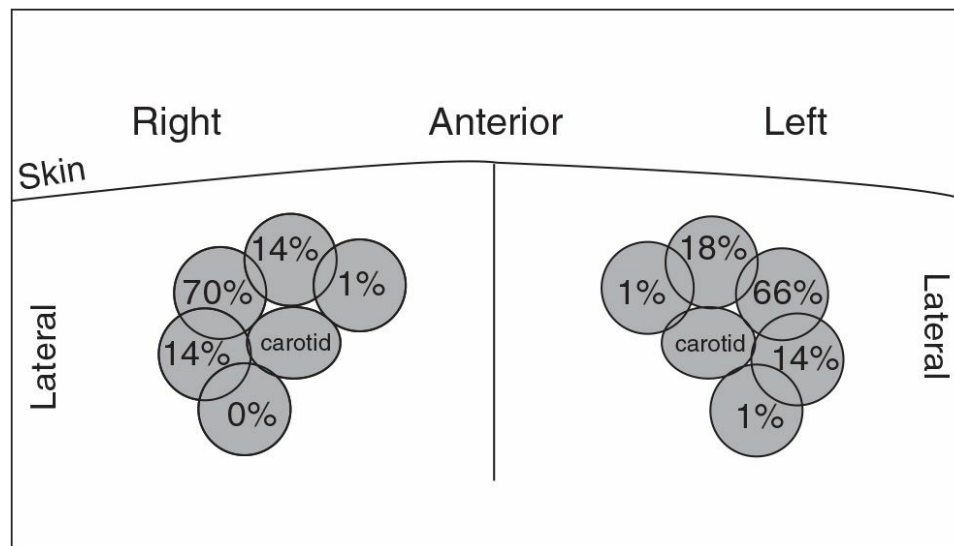

FIGURE 7.1 Anatomic variability of internal jugular vein as viewed using ultrasound localization. (Modified from Caridi JG, et al. Sonographic guidance when using the right internal jugular vein for central vein access. *Am J Roentgenol.* 1998;171:1259–1263.)

- E. **Simulation-based training for catheter insertion.** Venous catheter insertion for dialysis is a necessary skill for nephrology fellows to acquire, but many programs may not have resources to provide the required level of training. Simulation-based training has been proposed to remedy this, and provision of such intensive training has resulted in improved catheter-related outcomes (Clark and Barsuk, 2014).

IV. INSERTION TECHNIQUE

- A. **Initial site preparation.** The catheter should be inserted using an aseptic technique, with the operator wearing a sterile surgical gown and gloves in a maximum barrier protection environment. Prior to surgical scrub, it is helpful to examine the selected site using

ultrasound to ensure that the patient has a suitable vein in the selected location. The insertion site and surrounding areas should be cleansed with surgical scrub and draped appropriately (include shoulder and chest wall if a cuffed tunneled catheter is to be inserted). The ultrasound probe should be covered with a sterile sheath.

- B. **Internal jugular approach.** The ultrasound probe may be placed parallel to the long axis of the vessel and the cannulation needle inserted adjacent to the end or short axis of the probe. Alternatively, the probe may be placed perpendicular to the long axis of the vessel. This approach gives the vein the more typical appearance of a circle but limits the visualization of the needle. The vein typically collapses with gentle pressure of the probe, whereas the artery does not. Additionally, the vein diameter increases with Valsalva maneuver and can be easily observed with ultrasound. For internal jugular vein cannulation as an example, the ultrasound probe is placed parallel and superior to the clavicle, over the groove between the sternal and clavicular heads of the sternocleidomastoid muscle. It is important to avoid inserting the catheter through the muscle, as this is uncomfortable for the patient and leads to catheter dysfunction as the neck is rotated.
1. **Initial insertion of the guidewire through a 21G needle.** The site for insertion is infiltrated with local anesthesia. Using real-time ultrasound guidance, a 21G micropuncture needle with an attached syringe is inserted into the vein. The small needle limits potential complications if the carotid artery is inadvertently punctured compared to a larger 18G needle, which is usually included in commercially available dialysis catheter trays. Under direct visualization, the vein will be seen to gently push in before penetration of the anterior vein wall. The syringe is removed, and a 0.018" guidewire is inserted through the needle. The guidewire is advanced. The position of the guidewire is confirmed using fluoroscopy.
 2. **Insertion of the dilator over the guidewire.** The needle is then removed and a coaxial 5-French dilator is then advanced over the guidewire. The guidewire and 3-French inner translational dilator are removed, leaving the 5-French outer dilator in place. A flow switch or stopcock is attached to the dilator to prevent the possibility of an air embolism.
 3. **Uncuffed catheter insertion.** The next step depends on whether one is placing a noncuffed temporary or cuffed tunneled catheter. For temporary catheter placement, a standard 0.035" guidewire is advanced into the vein and then the 5-French dilator is removed, leaving the guidewire. In stepwise fashion, dilators of increasing size are passed over the guidewire to progressively dilate the soft tissue and venous tract; the dilator should move freely on the guidewire. The dilator should not be forcefully advanced, as it is possible for the dilator to get off axis and impinge on the guidewire and perforate the vein and/or the mediastinum. Consequently, one does not need to advance the entire length of the dilator as only the dilatation of the track from the skin to the vein is desired. If there is any doubt as to location of the dilator or if there is hesitancy or difficulty in dilating the tract, fluoroscopy should be used to assist in placement. The last dilator is then exchanged for the temporary catheter, which is advanced over the guidewire into position. After securing the catheter in place, a chest radiograph should be obtained for confirmation of correct positioning and to check for any complications,

if a fluoroscope was not available during insertion. If the patient requires long-term dialysis support, the temporary noncuffed catheter, when located in the internal jugular vein, may be safely converted to a cuffed tunneled catheter if there is no evidence of an exit-site infection.

4. **Cuffed catheter insertion**

- a. **Creating the skin exit site and tunnel.** For cuffed tunneled catheter insertion, a small skin incision is made from the 5-French dilator exit site extending laterally. The subcutaneous tissue is then exposed with blunt dissection, creating a subcutaneous pocket so that the catheter bend will be kink-free. Further dissection is made to ensure that the soft tissue around the 5-French dilator is free. The catheter exit site is then located. This may be accomplished by using the fourth rib interspace landmark technique, or the catheter length may be determined more precisely by using a guidewire to measure the distance from the insertion site to the midright atrium. Using this measurement as a guide, the length of tunnel may then be determined so that the cuff is within the tunnel approximately 1–2 cm from the exit site.
5. **Inserting the catheter through the skin exit site.** Once the exit site for the catheter is identified, the area is infiltrated with local anesthesia; a puncture is made through the skin using a number 11 knife blade inserted parallel to the skin. The knife is inserted to the widest point of the blade; this incision accommodates most dual-lumen catheters. A long needle is used to infiltrate the tunnel tract with local anesthesia extending from the exit site to the venotomy insertion site. The catheter is mounted on the end of the tunneling device, and the tunneling device is pulled from the exit site subcutaneously to the insertion site. The cuff of the catheter is pulled into the tunnel, and the tunneling device is then removed from the catheter.
6. **Dilating the deep tissues and venous tract.** A guidewire (Benson or angled glidewire) is now passed through the dilator into the inferior vena cava. Placement of the guidewire into the inferior vena cava decreases the likelihood of cardiac arrhythmias. The guidewire provided with most catheter trays may also be used. The 5-French dilator is then removed, and in stepwise fashion, dilators of increasing size are passed over the guidewire in order to progressively dilate the soft tissue and venous tract. The dilator should move freely on the guidewire. It is possible for the dilator to get off axis and impinge on the guidewire and perforate the vein and/or the mediastinum. In this context, one does not need to advance the entire length of the dilator as only the dilatation of the track from the skin to the vein is required. If there is any doubt as to the location of the dilator or if there is hesitancy or difficulty in dilating the tract, the fluoroscope should be used to verify proper positioning.
7. **Completing catheter insertion.** After the final dilation, the dilator is inserted with peel-away sheath. As one inserts the sheath, a resistance is felt as the sheath goes through the soft tissue and then a final resistance as it enters the vein. The dilator and sheath are then removed and the catheter is threaded over the guidewire without using the sheath and advanced through the venous tract into final position (sheathless catheter insertion). One may need to slightly torque the catheter in order to advance it through the tract.

This maneuver decreases the possibility of air embolism and may result in both a smaller venotomy and in less postprocedure bleeding.

Alternatively, if the peel-away sheath is used, the sheath is advanced slightly and the dilator removed while occluding the sheath, leaving the guidewire in place to ensure access is available if there are any difficulties. The sheath should be grasped between the finger and thumb of one's hand in order to occlude the sheath. This prevents bleeding and/or aspiration of air while leaving enough length of the sheath to insert the catheter. Once the dilator and guidewire have been removed, the catheter is threaded over the wire and advanced into the opening of the sheath in such a way as to avoid twisting the catheter. The catheter is fed through the sheath. The catheter is pushed farther into the sheath, and the sheath is peeled downward toward the skin. As soon as the catheter is advanced maximally, the sheath is pulled out and then peeled down outside of the venotomy. This avoids the sheath creating a larger venous tract.

8. **Setting and securing the catheter cuff.** Once the sheath has been completely removed, the catheter is pulled back into the tunnel so that the cuff now is approximately 1–2 cm from the exit site. The catheter is now checked to ensure that it is functioning properly. A 10-mL syringe should be able to rapidly pull back blood without any shuttering if the catheter is to deliver a blood flow >300 mL/min.

The venotomy insertion site at the neck is closed using appropriate suture after confirmation of adequate flow. Sutures should not be placed at the exit site as they serve as a nidus for infection. Additional suture is used to hold the catheter at the hub. Using “air knots” to secure the catheter hub increases patient comfort and decreases the likelihood of skin necrosis. The subcutaneous cuff will ultimately hold the catheter in position and anchor it to the subcutaneous tissue. Topical antibiotic ointment may be applied to the incisions and needle puncture sites, and a gauze dressing is applied.

- C. **Femoral approach.** Uncuffed catheters normally are used, but as noted earlier, cuffed catheters also may be inserted. The patient is placed flat on the back with the knee slightly flexed and leg abducted and rotated outward. The groin is shaved, cleansed, painted with antiseptic, and draped. The femoral vein should be located 2–4 cm below the inguinal ligament using a 21G needle filled with heparinized saline or with local anesthetic. As noted earlier, real-time ultrasound guidance improves the chance of a successful procedure. A small amount of local anesthetic can be infiltrated around the vein to prevent venous spasm. Once the vein is located, the small-gauge needle is withdrawn and replaced with an 18G needle. A guidewire is inserted through the needle into the vein. It is important for the guidewire to be freely movable back and forth after it is fully inserted. If the guidewire feels tight, chances are that it has entered a side branch of the iliofemoral vein. Under these circumstances catheter insertion should not be attempted; rather, the guidewire should be withdrawn completely, the angle of the needle in the vein changed (sometimes the needle hub has to be lowered to the skin level to be almost parallel to the vein), and the guidewire reinserted. After free to-and-fro movement of the inserted guidewire is achieved, the 18G needle is removed and the cannula reinserted. The remainder of the procedure then generally follows the description for jugular vein insertion, above.

V. **INSERTION-RELATED COMPLICATIONS.** These are listed in Table 7.2. Arterial puncture by the initial small-gauge probing needle should be treated by uninterrupted local pressure for 15–20 minutes. The cannula should never be inserted into an artery. In case of inadvertent arterial insertion of a dialysis catheter, dialysis should be postponed and surgical opinion sought to avoid a major hematoma and tracheal compression. In the case of femoral insertions, retroperitoneal bleeding may be severe and life-threatening with either puncture of the artery or inadvertent puncture of the back wall of the vein. A large pneumothorax or hemothorax usually requires drainage using a surgically implanted chest tube. Perforation of the superior vena cava or cardiac chambers can be life-threatening. Diagnosis is suggested by unexplained chest pain, shortness of breath or hypotension soon after commencing dialysis. Surgical intervention is sometimes needed for correction. Infection-related complications can be minimized at time of catheter insertion by assuring adequate hand hygiene, use of sterile gown, mask, gloves and caps for the operator, and a large (full body) sterile drape to cover the patient, and application of chlorhexidine skin antisepsis prior to the procedure (O’Grady, 2011).

VI. CARE AND USE OF VENOUS CATHETERS

A. **Dressings.** During catheter connect and disconnect procedures, both dialysis staff and patient should wear surgical masks. A face shield should not be used without a surgical mask because the shield tends to focus the wearer’s breath directly on the exposed catheter hub. The lumen and catheter tips should never remain open to air. A cap or syringe should always be placed on or in the catheter lumen while maintaining a clean field under the catheter connectors. Catheter lumens must be kept sterile: Interdialytic infusions through the catheter are forbidden.

TABLE

7.2

Complications of Central Venous Catheterization

Immediate Complications

- Arterial puncture (all)
- Pneumothorax (IJ, SC)
- Hemothorax (IJ, SC)
- Arrhythmias (IJ, SC)
- Air embolism (all IJ, SC >> F)
- Perforation of cardiac chamber (IJ, SC)
- Pericardial tamponade (IJ, SC)
- Retroperitoneal hemorrhage (F)

Delayed Complications

- Thrombosis (all)
- Infection (all)
- Central venous stenosis (SC >> IJ)
- Arteriovenous fistula (all)

Injury to Adjacent Structures

Brachial plexus (IJ, SC)

Recurrent laryngeal nerve (IJ, SC)

IJ, internal jugular; SC, subclavian; F, femoral.

After each dialysis, catheter hubs or blood line connectors should be soaked in antiseptic for 3–5 minutes, and then dried prior to separation. Chlorhexidine-based antiseptic solutions (>0.5%) appear to give better results than povidone-iodine (Mimoz, 2007; Onder, 2009). After disconnecting each line from the catheter, the threads of the catheter connector should be scrubbed with chlorhexidine (Table 7.3). The catheter should be covered with a sterile dry dressing. Nonbreathable or nonporous transparent film dressings should be avoided as they pose a greater threat of exit-site colonization than dry dressings. The best type of dressing to use is still a matter of controversy. The CDC recommendations are to “use either sterile gauze or sterile, transparent, semipermeable dressing to cover the catheter site” (O’Grady, 2011). The CDC has available resources including videos to show best practice techniques of making such catheter dressing changes (CDC, 2014).

- B. Risk of air embolism on removal of dialysis catheters from the neck.** After removal of a jugular venous catheter, lethal air embolism has been reported (Boer and Hené, 1999). Because of this nonnegligible risk, specific protocols should be in place for removal of venous catheters from the neck. The protocol recommended by Boer and Hené (1999) is as follows:
1. No heparin on day of planned removal. Protamine given if heparin is already on board
 2. Patient in head down position during catheter removal. Patient instructed not to cough or inhale deeply during removal
 3. Air-occlusive dressing with generous amount of an inert ointment to provide an instantaneous air seal
 4. Patient observed for 30 minutes before leaving dialysis facility
 5. Air-occlusive dressing left in place for at least 24 hours
- C. Catheter exchange over a guidewire (technique).** The reasons for catheter exchange over a guidewire (dysfunction, infection) are discussed in detail in Chapter 9. The technique for exchange of a catheter in the internal jugular vein is as follows: The chest wall and the old catheter are prepped and draped in a sterile fashion. The operators should wear two sterile gloves. Local anesthesia is infiltrated at the old exit site and around the cuff of the existing catheter. Both catheter ports are aspirated to get rid of the heparin. Using a hemostat, blunt dissection is performed to free up the catheter cuff. At this point, a guidewire is introduced into the venous lumen of the catheter and navigated into the inferior vena cava. The catheter is gently pulled back so that it is situated at the brachiocephalic vein. A contrast injection is performed through the atrial port of the catheter to ascertain the presence of fibroepithelial sheath. If present, percutaneous balloon angioplasty should be considered and contrast injection repeated to evaluate the results of the sheath treatment. The old catheter should be removed while the wire is kept in place.

At this point, the operator(s) should remove the outer pair of gloves before handling the

new catheter. This maneuver helps minimize the transfer of infectious organisms from the old catheter to the new catheter. The new catheter is then advanced over the wire and into the right atrium. The catheter function is assessed as described earlier.

TABLE

7.3

The Centers for Disease Control Core Interventions for Dialysis Bloodstream Infection (BSI) Prevention

- 1. Surveillance and feedback using NHSN**
Conduct monthly surveillance for BSIs and other dialysis events using CDC's National Healthcare Safety Network (NHSN). Calculate facility rates and compare with rates in other NHSN facilities. Actively share results with front-line clinical staff
- 2. Hand hygiene observations**
Perform observations of hand hygiene opportunities monthly and share results with clinical staff
- 3. Catheter/vascular access care observations**
Perform observations of vascular access care and catheter accessing quarterly. Assess staff adherence to aseptic technique when connecting and disconnecting catheters and during dressing changes. Share results with clinical staff
- 4. Staff education and competency**
Train staff on infection control topics, including access care and aseptic technique. Perform competency evaluation for skills such as catheter care and accessing every 6–12 months and upon hire
- 5. Patient education/engagement**
Provide standardized education to all patients on infection prevention topics including vascular access care, hand hygiene, risks related to catheter use, recognizing signs of infection, and instructions for access management when away from the dialysis unit
- 6. Catheter reduction**
Incorporate efforts (e.g., through patient education, vascular access coordinator) to reduce catheters by identifying and addressing barriers to permanent vascular access placement and catheter removal
- 7. Chlorhexidine for skin antisepsis**
Use an alcohol-based chlorhexidine (>0.5%) solution as the first-line skin antiseptic agent for central line insertion and during dressing changes^a
- 8. Catheter hub disinfection**
Scrub catheter hubs with an appropriate antiseptic after cap is removed and before accessing. Perform every time catheter is accessed or disconnected^b
- 9. Antimicrobial ointment**
Apply antibiotic ointment or povidone-iodine ointment to catheter exit sites during dressing change^c

^aPovidone-iodine (preferably with alcohol) or 70% alcohol by itself is alternative for patients with chlorhexidine intolerance.

^bIf closed needleless connector device is used, disinfect connector device as per manufacturer's

instructions.

^cCDC recommends using povidone-iodine ointment or bacitracin/gramicidin/polymyxin B ointment at the hemodialysis catheter exit site after catheter insertion and at each hemodialysis session. Bacitracin/gramicidin/polymyxin B ointment is not currently available in the United States. Triple antibiotic ointment (bacitracin/neomycin/polymyxin B) is available and might have a similar benefit but studies have not thoroughly evaluated its effect for prevention of bloodstream and exit-site infections. Other ointments that have been studied include single antibiotic ointments (e.g., mupirocin). However, concerns exist about development of antimicrobial resistance and also their ability to cover the spectrum of potential pathogens (e.g., gram-negative and gram-positive bacteria) that can cause bloodstream infections in dialysis patients. Another important consideration is that ingredients in antibiotic and povidone-iodine ointments may interact with the chemical composition of certain catheters. Therefore, before any product is applied to the catheter, first check with the catheter manufacturer to ensure that the selected ointment will not interact with the catheter material. Reprinted from National Center for Emerging and Zoonotic Infectious Diseases, Center for Disease Control and Prevention. http://www.cdc.gov/dialysis/PDFs/Dialysis-Core-Interventions-5_10_13.pdf.

D. **Bathing and showering.** The exit site should never be immersed in bath water. Showering is best avoided, but if the patient showers it should be done prior to coming to the dialysis unit, where a new dressing and antibacterial ointment will be promptly applied. Showering should be done only after the exit-site sinus tract has become established. A recent quality assurance study suggested that in selected patients, showering in combination with a no-dressing technique for tunneled central venous catheters did not increase infection risk (Lawrence, 2014). Immersive swimming, as in a chlorinated pool, is generally discouraged for fear of infection.

E. **Catheter locks**

1. **Heparin.** After each dialysis session, the dead space of each lumen is filled with heparin through the catheter injection ports using 1,000–5,000 units/mL. Any lock solution will leak out to the level of the most proximal side hole of the catheter. Thus, use of higher heparin concentration (5,000 vs. 1,000 units/mL) may result in significant systemic anticoagulation, but in one study, the higher heparin concentration was associated with lower need for tissue plasminogen activator use (Maya, 2010). The dead space of each catheter lumen varies among manufacturers and length of catheter. The required volume of heparin is usually labeled on the catheter hub. It is important to record this information on the patient's chart so it is readily available to the dialysis staff. Injection of a volume of heparin solution larger than necessary should be avoided as it results in some degree of systemic anticoagulation that may be hazardous to patients at risk for bleeding. Prior to each dialysis, the heparin in each lumen is aspirated, the catheter flushed with heparinized saline (100 units/mL), and hemodialysis initiated.
2. **Citrate 4%.** Citrate can be used as an anticoagulant because it chelates calcium, which is essential for clotting to occur. A meta-analysis performed in 2014 concluded that citrate-based lock solutions containing antibiotics or antiseptics were better than their heparin-containing counterparts in reducing the rate of central line-associated

bloodstream infection (CLABSI). Citrate alone was more effective than heparin, but primarily when a high concentration (30%) was used. At lower concentrations of citrate there seemed to be no advantage over heparin (Zhao, 2014). Citrate has been shown to leak out of catheter locks into the circulation fairly rapidly, quickly lowering its concentration to levels below those known to inhibit bacterial growth (Schilcher, 2014). In the United States, in the year 2000, use of very high concentrations of citrate in a dialysis catheter was associated with cardiac arrhythmia and patient death, presumably due to inadvertent injection of concentrated citrate into the left atrium, acutely lowering the ionized calcium level (Polaschegg and Sodemann, 2003). It is prudent to use the lowest concentration (4% citrate), recognizing that efficacy of citrate at this concentration alone may be no better than that of heparin. Citrate use at any concentration is problematic in countries (such as the United States) where it is not conveniently available in small volumes to be used for a locking solution.

3. **Other locks.** Other lock solutions have contained heparin, citrate, ethanol, or EDTA plus one or more antibiotics or antiseptics. For the moment, use of antibiotic-containing locks has not yet become mainstream, due in various proportions to added cost, practical issues relating to compounding, and fear of promoting growth of resistant organisms. A locking solution containing vancomycin and gentamicin was found to increase the prevalence of *Staphylococcus* and antibiotic-resistant *Enterobacter*, for example (Dixon, 2012). For the moment, neither the CDC nor the US National Kidney Foundation recommend the routine use of lock solutions containing antibiotics (Camins, 2013), while the European Best Practices Group is somewhat equivocal (Vanholder, 2010).

Lock solution for prevention of infections in catheters is an active area of research. One goal is not only to sterilize the inside of the catheter but also to prevent the formation of biofilm. Locking solutions containing ethanol, citrate, or EDTA have a theoretical advantage of having some activity in affecting biofilm development. A solution containing glyceryl trinitrate, citrate, and ethanol has been reported to have some effects against not only common bacteria found in catheters but also biofilm (Rosenblatt, 2013). Other locking solutions have been developed and are in various stages of testing. A mixture of citrate, methylene blue, methylparaben, and propylparaben (C-MB-P) was reported to reduce the rate of CLABSIs by a substantial amount (Maki, 2011). There is some enthusiasm about locks containing a combination of taurolidine and citrate. It is possible that the use of taurolidine, which tends to function as a disinfectant and which inhibits the formation of biofilm, may not be associated with emergence of resistant bacteria (Liu, 2014).

- F. **Prophylactic antibiotics.** Systemic antibiotics are not given routinely prior to cuffed catheter insertion.

1. **Exit-site ointment.** Mupirocin ointment treatment of the catheter exit site to lower *Staphylococcus* colonization has been shown to reduce the catheter infection rate and to increase the catheter survival rate (McCann and Moore, 2010; O'Grady, 2011), but is not widely used for fear of long-term emergence of mupirocin-resistant organisms. The CDC recommends using exit-site ointments (Table 7.3) but is very concerned

about the emergence of resistant organisms. The European Renal Best Practices group, in a 2010 commentary, recommends use of exit-site antibiotic ointment only until the insertion site has healed (Vanholder, 2010). As an intermediate strategy, use of exit-site ointments can be limited to those patients who evidence repeated episodes of infection. Prior to use of any ointment, one should check to make sure that the vehicle used to dissolve the ointment does not adversely react with the plastics in the catheter material.

2. **Nasal decolonization.** In patients harboring *Staphylococcus* in the nose, nasal decolonization has been shown to reduce the rate of CLABSI (Abad, 2013), but the specter of mupirocin resistance remains (Teo, 2011). This remains a more attractive treatment option in selected patients than for the unit as a whole, but nasal decolonization (of multidrug-resistant *S. aureus*, for example) has been applied to entire dialysis units with encouraging short-term results (Kang, 2012).

References and Suggested Readings

- Abad CL, et al. Does the nose know? An update on MRSE decolonization strategies. *Curr Infect Dis Rep.* 2013;15:455–464.
- Allon M. Dialysis catheter-related bacteremia: treatment and prophylaxis. *Am J Kidney Dis.* 2004;44:779–791.
- Beathard GA. Management of bacteremia associated with tunneled-cuffed hemodialysis catheters. *J Am Soc Nephrol.* 1999;10:1045–1049.
- Beaudoin FL, et al. Bedside ultrasonography detects significant femoral vessel overlap: implications for central venous cannulation. *Can J Emerg Med.* 2011;13:245–250.
- Bevilacqua JL, et al. Comparison of trisodium citrate and heparin as catheter-locking solution in hemodialysis patients. *J Bras Nefrol.* 2011;33:68–73.
- Boer WH, Hené RJ. Lethal air embolism following removal of a double lumen jugular catheter. *Nephrol Dial Transplant.* 1999;14:1850–1852.
- Camins BC. Preventions and treatment of hemodialysis-related bloodstream infections. *Semin Dial.* 2013;26:476–481.
- Centers for Disease Control. Guidelines of the prevention of intravascular catheter-related infections. 2011. <http://www.cdc.gov/hicpac/pdf/guidelines/bsi-guidelines-2011.pdf>.
- Centers for Disease Control. Training video and print resources for preventing bloodstream and other infections in outpatient hemodialysis patients. Best practices for dialysis staff. 2014. <http://www.cdc.gov/dialysis/prevention-tools/training-video.html>.
- Clark EG, Barsuk JH. Temporary hemodialysis catheters: recent advances. *Kidney Int.* 2014. doi:10.1038/ki.2014.162.
- Clase CM, et al. Thrombolysis for restoration of patency to hemodialysis central venous catheters: a systematic review. *J Thromb Thrombolysis.* 2001;11(2):127–136.
- Dixon JJ, Steele M, Makanjuola AD. Anti-microbial locks increase the prevalence of *Staphylococcus aureus* and antibiotic-resistant *Enterobacter*: observational retrospective cohort study. *Nephrol Dial Transplant.* 2012;27:3575–3581.
- Drew DA, Lok CE. Strategies for planning the optimal dialysis access for an individual patient. *Curr Opin Nephrol Hypertens.* 2014;23:314–320.

- Dugué AE, et al; for the Cathedia Study Group. Vascular access sites for acute renal replacement in intensive care units. *Clin J Am Soc Nephrol*. 2012;7:70–77.
- Frankel A. Temporary access and central venous catheters. *Eur J Vasc Endovasc Surg*. 2006;31:417–422.
- Haymond J, et al. Efficacy of low-dose alteplase for treatment of hemodialysis catheter occlusions. *J Vasc Access*. 2005;6:76–82.
- Hebert C, Robicsek A. Decolonization therapy in infection control. *Curr Opin Infect Dis*. 2010;23:340–345.
- Hingwala J, Bhola C, Lok CE. Using tunneled femoral vein catheters for “urgent start” dialysis patients: a preliminary report. *J Vasc Access*. 2014;15(suppl 7):101–108.
- Johnson DW, et al. A randomized controlled trial of topical exit site mupirocin application in patients with tunneled, cuffed haemodialysis catheters. *Nephrol Dial Transplant*. 2002;17:1802–1807.
- Kang YC, et al. Methicillin-resistant *Staphylococcus aureus* nasal carriage among patients receiving hemodialysis in Taiwan: prevalence rate, molecular characterization and de-colonization. *BMC Infect Dis*. 2012;12:284.
- Lawrence JA, et al. Shower and no-dressing technique for tunneled central venous hemodialysis catheters: a quality improvement initiative. *Nephrol Nurs J*. 2014;41:67–72.
- Lee T, Barker J, Allon M. Tunneled catheters in hemodialysis patients: reasons and subsequent outcomes. *Am J Kidney Dis*. 2005;46:501–508.
- Little MA, Walshe JJ. A longitudinal study of the repeated use of alteplase as therapy for tunneled hemodialysis dysfunction. *Am J Kidney Dis*. 2002;39:86–91.
- Liu H, et al. Preventing catheter-related bacteremia with taurolidine-citrate catheter locks. A systemic review and meta-analysis. *Blood Purif*. 2014;37:179–187.
- Lok CE, et al. A patient-focused approach to thrombolytic use in the management of catheter malfunction. *Semin Dial*. 2006;19:381–390.
- Maki DG, et al. A novel antimicrobial and antithrombotic lock solution for hemodialysis catheters: A multi-center, controlled, randomized trial. *Crit Care Med*. 2011;39:613–620.
- Maya ID, Allon M. Outcomes of tunneled femoral hemodialysis catheters: comparison with internal jugular vein catheters. *Kidney Int*. 2005;68:2886–2889.
- Maya ID, et al. Does the heparin lock concentration affect hemodialysis catheter patency? *Clin J Am Soc Nephrol*. 2010;5:1458–1462.
- McCann M, Moore ZE. Interventions for preventing infectious complications in haemodialysis patients with central venous catheters. *Cochrane Database Syst Rev*. 2010;(1):CD006894.
- Mermel LA, et al. Guidelines for the management of intravascular catheter-related infections. *Clin Infect Dis*. 2001;32:1249–1272.
- Mimoz O, et al. Chlorhexidine-based antiseptic solution vs alcohol-based povidone-iodine for central venous catheter care. *Arch Intern Med*. 2007;167:2066–2067.
- Mokrzycki MH, et al. A randomized trial of minidose warfarin for the prevention of late malfunction in tunneled, cuffed hemodialysis catheters. *Kidney Int*. 2001;59:1935–1942.
- Murea M, et al. Risk of catheter-related bloodstream infection in elderly patients on hemodialysis. *Clin J Am Soc Nephrol*. 2014;9:764–770.
- O’Grady NP, et al. Guidelines for the prevention of intravascular catheter-related infections. *Am J Infect Control* 2011;39(suppl):S1–S34.

- Oliver MJ, et al. Risk of bacteremia from temporary hemodialysis catheters by site of insertion and duration of use: a prospective study. *Kidney Int.* 2000;58:2543–2545.
- Onder AM, et al. Chlorhexidine-based antiseptic solutions effectively reduce catheter-related bacteremia. *Pediatr Nephrol.* 2009;224:1741–1747.
- Patel PR, et al. Bloodstream infection rates in outpatient hemodialysis facilities participating in a collaborative prevention effort: a quality improvement report. *Am J Kidney Dis.* 62:322–30, 2013.
- Polaschegg HD, Sodemann K. Risks related to catheter locking solutions containing concentrated citrate. *Nephrol Dial Transplant.* 2003;18:2688–2690.
- Rabindranath KS, et al. Ultrasound use for the placement of haemodialysis catheters. *Cochrane Database Syst Rev.* 2011;(11):CD005279.
- Rosenblatt J, et al. Glyceryl trinitrate complements citrate and ethanol in a novel antimicrobial catheter lock solution to eradicate biofilm organisms. *Antimicrob Agents Chemother.* 2013;57:3555–3560.
- Schilcher G, et al. Loss of antimicrobial effect of trisodium citrate due to ‘lock’ spillage from haemodialysis catheters. *Nephrol Dial Transplant.* 2014;29:914–919.
- Silva TNV, et al. Approach to prophylactic measures for central venous catheter-related infections in hemodialysis. A critical review. *Hemodial Int.* 2014;18:15–23.
- Teo BW, et al. High prevalence of mupirocin-resistant staphylococci in a dialysis unit where mupirocin and chlorhexidine are routinely used for prevention of catheter-related infections. *J Med Microbiol.* 2011;60(pt 6):865–867.
- Vanholder RM, et al. Diagnosis, prevention, and treatment of haemodialysis catheter-related bloodstream infections (CRBSI): a position statement of European Renal Best Practice (ERBP). *Nephrol Dial Transplant.* 2010;3:234–246.
- Zhao Y, et al. Citrate versus heparin lock for hemodialysis catheters: a systematic review and meta-analysis of randomized controlled trials. *Am J Kidney Dis.* 2014;63:479–490.

Web References

- American Society of Diagnostic and Interventional Nephrology. <http://www.asdin.org/>.
- CDC guidelines for prevention of intravascular catheter-related infections. <http://www.cdc.gov/dialysis>.
- HDCN vascular access channel. <http://www.hdcn.com/ch/access/>.
- KDOQI 2006 access guidelines. http://www.kidney.org/professionals/kdoqi/guideline_upHD_PD_VA/index.htm.
- Vascular Access Society guidelines. <http://www.vascularaccesssociety.com/guidelines.html>.
- YouTube link (11 min). https://www.youtube.com/watch?v=_0zhY0JMGCA&feature=youtu.be.

8

Arteriovenous Vascular Access Monitoring and Complications

Alexander Yevzlin, Anil K. Agarwal,
Loay Salman, and Arif Asif

Once the AV access has been in use, the most important factors that limit its survival are stenosis, thrombosis, and infection. In general, complications occur more commonly in grafts than in AV fistulas.

- I. **STENOSIS.** Vascular access stenosis is a harbinger of thrombosis, reduces access blood flow, and can lead to underdialysis. The most common cause of stenosis in AV grafts is neointimal hyperplasia, which usually occurs at or just distal to the graft–vein anastomosis. In AV fistulas, the location and cause of stenosis is more varied, with the juxta-anastomotic region being a frequent site. Common sites of stenosis in AV fistulas and grafts are shown in Figures 8.1 and 8.2. Because access patency is much worse after thrombectomy than after elective angioplasty, current KDOQI guidelines recommend prospective monitoring and surveillance of AV fistulas and grafts for hemodynamically significant stenosis. Not all guidelines recommend routine monitoring, however, and there is controversy regarding the overall clinical benefit of maintaining an access surveillance program (Kumbar, 2012; Paulson, 2012). Randomized controlled trials have not consistently shown that surveillance improves outcomes in grafts; in fistulas, surveillance has been shown to reduce the rate of thrombosis, but may not prolong overall fistula life.

There are several strategies to detect stenosis prior to definitive visualization of the access tract by Doppler ultrasound and, in the case of central vein stenosis, by venography. These early detection strategies depend on indirectly observing access pressure, flow, or recirculation during dialysis. The optimum early detection strategy differs somewhat for fistulas versus grafts, and for forearm versus upper arm locations. The basic principles are these: (a) Recirculation of dialyzed blood across the access device immediately back through the dialysis circuit does not appear until access flow decreases to a level near to or less than flow in the extracorporeal circuit. Thus, barring inadvertent needle reversal or improper needle placement, access recirculation will not be present until access flow falls to the range of 350–500 mL/min. At this range of flow, AV grafts are already at high risk for thrombosis, so if true recirculation is detected in an AV graft, it is an urgent indication to image the graft and correct the stenosis. On the other hand, in AV fistulas, continued patency is likely even when recirculation is present (flow in the 350–500-mL/min range). The benefits of screening AV fistulas for access recirculation are relatively small in terms of preventing thrombosis, but screening for

recirculation is useful to prevent underdialysis. Access stenosis that occurs between the usual sites of needle insertion will not cause recirculation, but may markedly reduce access flow to thrombosis-prone levels. Stenosis in this location should be suspected when access flows are measured to be below the blood pump flow rate, but recirculation is not detectable. (b) Both grafts and fistulas commonly develop inflow stenosis, so strategies that detect inflow stenosis will be useful for both types of AV access. (c) Outflow stenosis occurs much more frequently in grafts than in forearm fistulas where the degree of neointimal hyperplasia is less and where accessory outflow veins often compensate for obstruction of a principal outflow channel. However, in upper arm fistulas, outflow stenosis is not uncommon. Hence, strategies that detect outflow stenosis will be more useful in monitoring function of AV grafts and of upper arm fistulas.

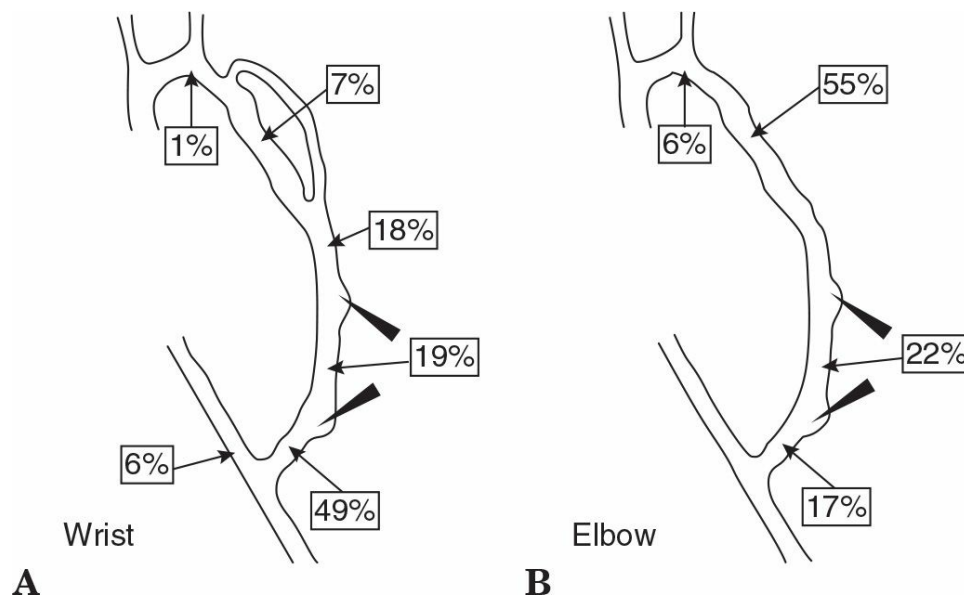

FIGURE 8.1 Common sites of stenosis in AV fistula. Locations are shown in fistulae created at wrist (A) and fistulae created at elbow (B). (From Turmel-Rodrigues L, et al. Treatment of stenosis and thrombosis in haemodialysis fistulas and grafts by interventional radiology. *Nephrol Dial Transplant* 2000;15:2032–2036, with permission.)

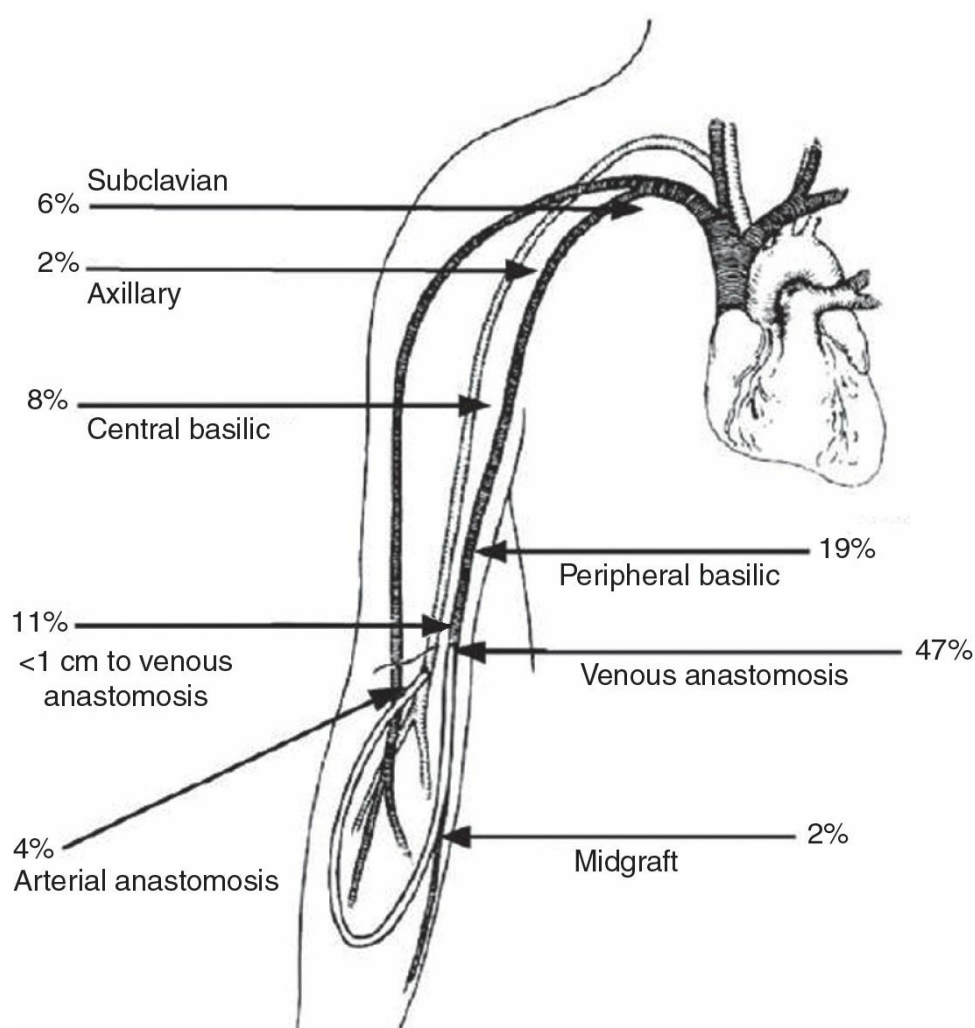

FIGURE 8.2 Common sites of stenosis in AV graft. (Reproduced from Roy-Chaudhury P, et al. Vascular access in hemodialysis: issues, management, and emerging concepts. *Cardiol Clin.* 2005;23:249–273, with permission from Elsevier.)

- A. **Physical examination** of an AV access was discussed in some detail in Chapter 6. Table 8.1 shows the changes in physical findings with some common access complications. Physical examination can be quite useful in detecting isolated inflow or outflow access stenoses, but is less effective in detecting combined inflow and outflow lesions. The accuracy of physical examination is substantially higher if the persons doing the examination have received special training (Coentrão, 2012). The ESRD Network of Texas has sponsored some training documents and examples, which are available on the Web (Beathard, 2012).
- B. **Access surveillance using information obtained routinely during every dialysis session.** Many dialysis machines have the option of measuring in vivo ionic dialysance. In all dialysis machines, the outflow venous pressure is monitored. Trending the results of these measurements over time can help detect access stenosis.
 1. **Trending ionic dialysance.** The ionic dialysance measured via conductivity includes any access recirculation component if present; as the degree of access recirculation increases, the in vivo ionic dialysance will decrease, assuming that other features of the dialysis prescription (dialyzer K_0A , blood and dialysate flow rates, heparinization) are kept constant. Dialysis machines that measure ionic dialysance typically integrate the clearances measured during each treatment (K) to calculate a treatment Kt value

(clearance \times time) for that session. In one case series of six patients with AV fistulas, a sustained fall in Kt of 20% was associated with access recirculation (Fontseré, 2011). Another approach is to follow the ratio of ionic dialysance to blood flow. In one report, a ratio of ≤ 0.5 had a high sensitivity and specificity for access recirculation (Mohan, 2010).

TABLE

8.1

Physical Findings with Various Forms of Access Dysfunction

Parameter	Normal	Inflow Stenosis	Outflow Stenosis	Coexisting Inflow and Outflow Stenosis	Central Stenosis	Clotted Access
Pulse	Soft, easily compressible	Feeble pulse (hypopulsation)	Hyperpulsation (water-hammer pulse, angry pulse)	Soft, easily compressible pulse	Variable	Absent pulse
Thrill	Continuous	Discontinuous (in severe inflow stenosis the thrill can be absent)	Higher pitched, louder, then discontinuous (in severe outflow stenosis the thrill can be absent)	Discontinuous (usually absent)	Variable	Absent thrill
Augmentation Test	Normal	Poor augmentation	Good augmentation	Poor augmentation	Good augmentation	
Arm Elevation Test (fistula only)	Normal collapse	Normal or accentuated collapse	No collapse	No collapse	No collapse	
Clinical Features	No prolonged bleeding or difficulty in cannulation	Difficulty in cannulation and an increase in negative arterial pressure	Prolonged bleeding and high venous pressure		Edema of the arm and shoulder, breast, supraclavicular, neck and face swelling	Sometimes clots aspiration from the access
Access Flow	Normal	Decreased	Decreased	Decreased	Variable	Absent

2. **Trending venous outflow pressures.** Venous pressures are measured continuously during routine hemodialysis. Venous pressures are a function of needle size, hematocrit (by its effect on blood viscosity), and blood flow rate. All other things being equal, a progressive rise in venous pressure over time (weeks to months) is often due to access outflow stenosis (Zasuwa, 2010). Some large dialysis organization data systems are able to track such pressures and trend them over time, and one company in the United States (Vasc-Alert, Lafayette, IN) sells software that allows easy access to trended pressure data. One can also trend prepump arterial pressure, which will increase (in a negative direction) with worsening access inflow stenosis.

The sensitivity of pressure measurements during dialysis to detect access stenosis can be increased by focusing on measurements taken at the beginning of dialysis with the blood flow rate set at a low value (200–225 mL/min), because at high blood flow rates, much of the resistance to flow is from the needle and not the vascular access. A baseline pressure value should be established when the access is first used. The threshold pressure that triggers further evaluation depends on the size of the needle, blood viscosity, and other factors; for 15G needles, a starting venous pressure threshold to use might be >115–120 mm Hg; for 16G needles, the threshold might be >150 mm Hg. Such threshold pressures must be exceeded on three or more treatments in succession to be significant.

C. **Periodic measurements of access blood flow rate.** To what extent a low access flow rate reflects stenosis and an increased risk of thrombosis depends on the type of access. Flow through a forearm AV fistula commonly averages 500–800 mL/min, and in grafts, flow is somewhat higher, about 1,000 mL/min. Flow in upper arm fistulas or grafts may be considerably higher. AV fistulas may maintain patency at flows as low as 200 mL/min, whereas AV grafts begin to clot at access flows between 600 and 800 mL/min—flows that often provide adequate dialysis but offer few clinical premonitory signs that the access is at risk

for thrombosis. The current KDOQI (2006) recommendations are to have the patient referred for access visualization if access flow is <600 mL/min or if the access flow is $<1,000$ mL/min and has decreased by $>25\%$ over the preceding 4 months. While regular surveillance of vascular access for stenosis has been shown to decrease thrombosis rates when compared with historical controls, recent prospective studies have not shown conclusively that detection of stenosis and correction with angioplasty improves graft survival.

1. **Direct measurement of access flow by saline dilution.** This method for measuring access blood flow during hemodialysis treatments was pioneered by Krivitski (1995). The required equipment is made by Transonic Systems, Inc. (Ithaca, NY) and consists of a control box, two matched flow/dilution sensors, a laptop computer, a data analysis software package, and a rolling stand that can be easily moved between patients (Fig 8.3). The setup shown in Fig. 8.3 is for measurement of access recirculation; hence the needles are not reversed. To measure access blood flow, one must deliberately cause access recirculation in the extracorporeal blood circuit by reversing the arterial and venous lines so that the dialyzer is fed from the downstream access needle (Fig 8.4). The degree of recirculation in such a system will depend on the ratio of the access blood flow rate to the rate of blood flow through the dialyzer. If the percentage recirculation and blood flow rate through the dialyzer are known, the access blood flow rate can then be calculated.

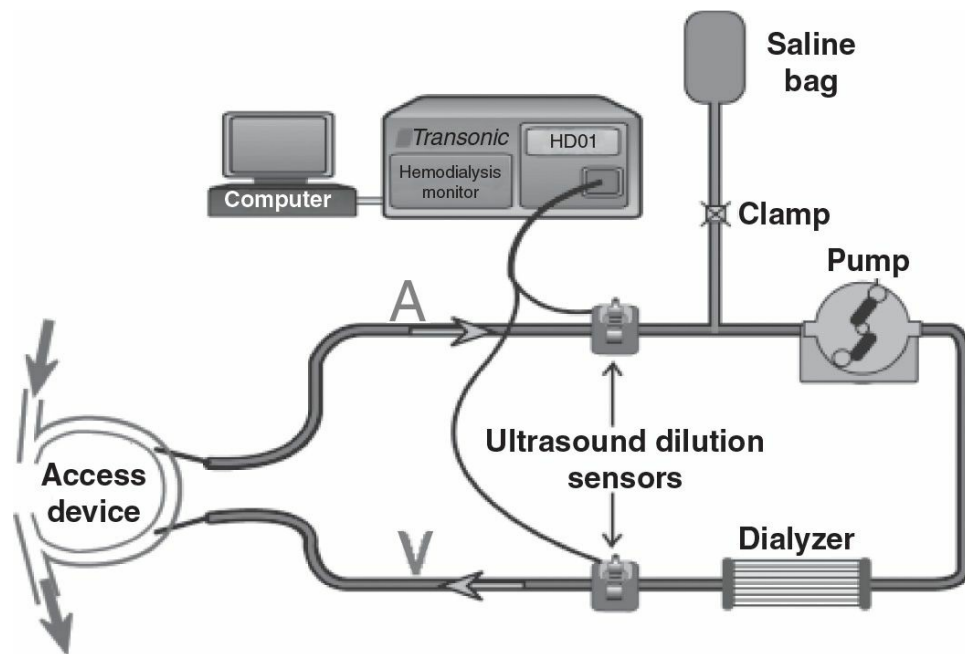

FIGURE 8.3 Setup to measure access recirculation by saline dilution and ultrasound detection. To measure access blood flow, the access needles need to be reversed (not shown). See text for description of the setup and method. (Reproduced with permission from Transonic Systems, Inc., Ithaca, NY.)

To measure the amount (percentage) of recirculation under needle-reversed conditions, a bolus of saline is injected into the blood leaving the dialyzer (Fig. 8.4). The amount of dilution in the outlet bloodline is measured by a downstream ultrasound

sensor. The speed of sound through blood depends on the concentration of proteins in the plasma; accordingly, the dilution effect of the saline bolus in the outlet bloodline can be quantified using this first sensor. Some of this saline-diluted blood will then traverse the vascular access segment between the two needles and reappear at the dialyzer inlet. The proportion of the saline-diluted blood that reappears at the dialyzer inlet depends on the ratio of access blood flow to the blood flow through the dialyzer. A second ultrasound sensor on the bloodline leading to the dialyzer is then used to detect the proportion of saline-diluted blood that reappears at the dialyzer inlet (Fig. 8.4). In practice, an additional measurement of recirculation is made with the blood lines not reversed, as the presence of any recirculation under nonreversed conditions will affect the calculations.

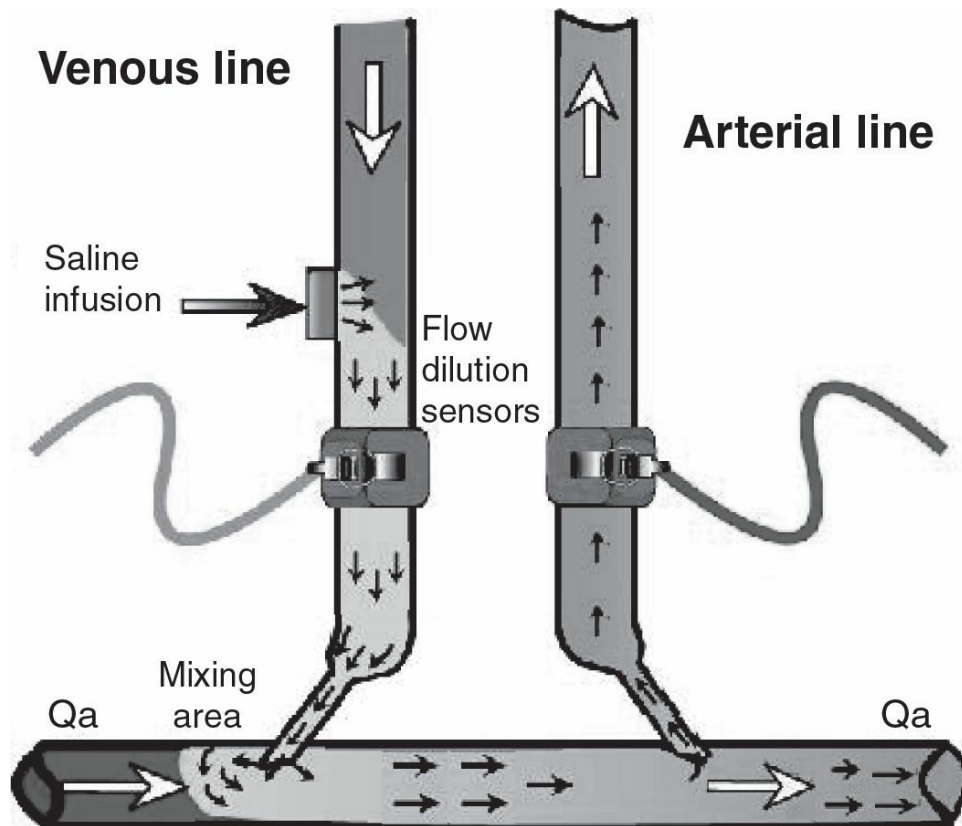

FIGURE 8.4 Measurement of access flow by saline dilution showing blood line reversal and position of blood line sensors. See text for details of the method. (Reproduced with permission from Transonic Systems, Inc., Ithaca, NY.)

2. **Alternative measures of access flow using temperature, sodium, or hemoglobin changes.** The Fresenius Blood Temperature Module has the ability to acutely change the temperature of the blood leaving the dialyzer, and the ionic conductivity module has the ability to acutely change the sodium concentration of blood leaving the dialyzer. This is done by abruptly altering the dialysis solution temperature or conductivity, respectively. This permits measurement of access blood flow rate in a similar method to saline dilution. The lines are reversed, the dialyzer blood outlet temperature or conductivity is altered, and the amount of this perturbation that gets transmitted to the dialyzer inlet via forced recirculation is calculated. The intervention is repeated without reversing the

bloodlines as a control. Hemoglobin dilution using an online hemoglobin monitor has been used to measure access blood flow in an analogous fashion (Jiang, 2011; Rocathey, 2012). Evidence suggests that these alternative methods are fairly accurate in measuring access blood flow, with the temperature method perhaps performing at a higher level (Badr, 2014). The advantage of using temperature or ionic dialysance is that the need for a separate ultrasound dilution sensor and laptop computer is no longer required.

- D. **Doppler ultrasonography to measure access flow.** Doppler ultrasonography, though usually used to detect stenotic lesions directly, can also be used to measure the rate of flow through a vascular access. A variety of machines and several different flow velocity algorithms have been used. There is systematic underestimation or overestimation of flow by some machines. Flow measurement by Doppler depends on an accurate measurement of both velocity and vessel diameter. This may be difficult when flow is turbulent in an access and when the vessel diameter is not uniform. Because of these confounders, flow is better measured at the brachial artery, where the vessel is a smooth cylinder of blood and flow is nonturbulent. Almost all of the flow in the brachial artery (apart from about 60–80 mL/min nutrient flow) passes through the vascular access, and brachial artery flow correlates very well with access flow rate.
- E. **Intra-access pressure (P_{IA}) and access flow.** Flow, pressure, and resistance are mathematically related. In an AV graft, the P_{IA} is usually <50% of MAP (mean arterial pressure). Most of this pressure drop occurs at the arterial anastomosis, unless there is intragraft stenosis. When outflow stenosis develops (e.g., due to neointimal hyperplasia at or downstream from the graft–vein anastomosis), P_{IA} rises and flow decreases. When P_{IA} rises above 50% of the MAP ($P_{IA}/MAP >0.50$), graft flow commonly has decreased into the thrombosis-prone range of 600–800 mL/min, and the presence of stenosis is likely. Details of how to compute this ratio based on an equivalent P_{IA} ($EQP_{IA} = P_{IA}$ adjusted for the relative heights of the access measuring point and pressure transducer) are given in Table 8.2. In AV fistulas, blood entering the venous system returns via multiple collateral veins. As a consequence, P_{IA} in an AV fistula, which is on average lower than in an AV graft, may not increase with outlet stenosis and is therefore less valuable as a surveillance tool.

If a stenosis develops in the body of an AV graft between the areas used for arterial and venous limb cannulation, P_{IA} at the venous needle remains normal or can even decrease, despite increasing stenosis. Stenosis at the arterial anastomosis of both grafts and fistulas causes P_{IA} to decrease, and a widely patent arterial anastomosis causes high basal P_{IA} in the absence of stenosis.

TABLE

8.2

Measuring the EQP_{IA}/MAP Ratio

Example:

1. Measure MAP: Assume that BP is 190/100. MAP is diastolic plus one-third of pulse pressure, or 130 mm Hg.
 2. Measure static intra-access pressure:
 - a. With the blood pump off and the blood line upstream to the venous drip chamber clamped, the venous drip chamber pressure is 60 mm Hg.
 - b. Compute offset using equation: $\text{offset (mm Hg)} = -1.6 + 0.74 \times H \text{ (cm)}$, where H is the height between the access and middle of the drip chamber. Assume H is 35 cm. Then $\text{offset} = -1.6 + 25.9 = 24.3$ mm Hg.
 - c. Add offset to compute EQP_{IA} : $\text{EQP}_{\text{IA}} = 60 + 24.3 = 84.3$ mm Hg.
 - d. Compute the $\text{EQP}_{\text{IA}}/\text{MAP}$ ratio. In this case, $84/130 = 0.65$, which is >0.5 . This access is at risk for stenosis.
-

EQP_{IA} , equivalent intra-access pressure; MAP, mean arterial pressure; BP, blood pressure.

Source: Besarab A, et al. Simplified measurement of intra-access pressure. *J Am Soc Nephrol.* 1998;9:284–289

F. **Access recirculation.** Both urea-based and non-urea-based (e.g., ultrasound dilution) techniques have been used to detect recirculation. The urea-based methods have been described in Chapter 3. The ultrasound dilution technique described earlier can be used to measure recirculation. In this case, the blood lines are not reversed. If dialyzer outlet blood is recirculating through the access and diluting the dialyzer inlet, the bolus of saline injected into the outlet blood line will be detected by the sensor located on the inlet blood line soon after injection. Measurement of access recirculation by thermal dilution using a blood temperature module yields results similar to those obtained by the ultrasound dilution technique. Recirculation exceeding 10% using the recommended two-needle urea-based method, 5% using the ultrasound dilution method, or 15% using the thermal dilution method should prompt investigation.

II. IMAGING THE VASCULAR ACCESS

- A. **Doppler ultrasonography.** This noninvasive technique allows direct imaging of the flow pattern in AV grafts and fistulas. It has been useful for detecting stenoses and for mapping aneurysms. Doppler flow measurements are prohibitively expensive for routine assessment. Their chief role is in the evaluation of flow and anatomy in accesses that have been screened by other techniques.
- B. **Access angiography.** Most centers refer patients with a high probability of stenosis as determined by low-cost methods directly for angiography and balloon angioplasty, bypassing Doppler altogether. One should use the lowest possible dose of nonosmotic contrast agent, diluted, if possible. Angiography can be used for limited evaluation of the arterial tree as well.
- C. **Magnetic resonance angiography (MRA).** The 2007 European Best Practice guidelines recommend use of MRA to image the vascular access when there is the need to see both the venous and the arterial parts of the upper extremity circulation (Tordoir, 2007). The

European guidelines cite a number of studies where MRA has been used successfully for access visualization. The incidence of nephrogenic systemic fibrosis with gadolinium is reduced with the newer contrast agents (Coca and Perazella, 2011), but the cumulative risk of multiple MRA procedures in dialysis patients has not been well quantified.

III. PERCUTANEOUS INTERVENTION AFTER ACCESS STENOSIS HAS BEEN IDENTIFIED. Once a stenosis >50% is detected, percutaneous transluminal catheter angioplasty or surgical revision of the lesion should be performed if one or more of the following are present: (a) abnormal physical examination, (b) previous history of thrombosis, (c) decreasing access flow, and (d) elevated or increasing measured static intra-access pressures (normalized to MAP). The expertise at each institution should determine which procedure is to be performed. If repeated angioplasties have been required within a short period for the same lesion, surgical revision should be considered.

In most institutions, vascular access–related procedures are performed by surgeons and interventionalists. Numerous centers in the United States now offer the nephrologist formal training in the techniques of percutaneous angioplasty and thrombectomy. Because nephrologists have a different clinical perspective of patients and their access-related problems, their direct involvement in interventional procedures may help minimize delays, decrease hospitalizations and costs, and increase overall patient satisfaction.

- A. Treatment of early AV fistula dysfunction.** A significant number (10%–35%) of AV fistulas do not adequately develop and fail to sustain dialysis therapy. Vascular stenosis or the presence of a significant accessory vein (an accessory vein is described as a side branch coming off the main venous channel that comprised the fistula) alone or in combination are the main culprits. Of the two problems (stenosis and accessory veins), stenosis is present in over 70% of the cases of fistula nonmaturation. In most cases, the stenosis will be found close to the anastomosis (a juxta-anastomotic lesion). Percutaneous balloon angioplasty can successfully treat this lesion and salvage a great majority of otherwise failed fistulae. In cases of nonmaturation due to the presence of accessory veins, an obliteration procedure using one of the three techniques (percutaneous ligation, venous cutdown, or coil insertion) can be used to salvage the failing fistula.
- B. Flow measurements immediately after access revision.** Sometimes radiographic correction of an apparent stenosis does not result in improvement in the access blood flow rate. At other times, access blood flow initially increases, but then falls back to pretreatment levels within a day or two of the procedure. Measurement of access flow immediately after a revision or angioplasty is helpful in terms of determining the likelihood that the access will remain open for a clinically useful period.
- C. Endovascular stents and vascular stenosis.** Endovascular stents have emerged as an important strategy to treat vascular access stenosis. Interventionalists use stents primarily to treat stenoses associated with AV grafts located at or just distal to the graft–vein anastomosis. Stents are also used in the management of pseudoaneurysms (see later). A stent graft is a metal stent with PTFE covering its internal surface, external surface, or both. Recently, a large multicenter, randomized, controlled trial (Haskal, 2010) found better patency rates for stent graft versus simple angioplasty for treatment of stenosis at the graft–vein anastomosis. Primary patency at 6 months for lesions treated with a stent graft (51%) was

superior to that for stenoses treated by angioplasty alone (23%; $P < 0.001$).

It is not uncommon for the dialysis access to be affected by several coexisting stenoses. The benefits of fixing one primary target lesion might be less important in the presence of such coexisting stenoses that might require placement of additional stent grafts. The cost increment when using an endovascular stent must be balanced against the cost of an angioplasty alone or the alternative of primary surgical repair.

IV. THROMBOSIS. Thrombosis is the most common complication of arteriovenous access and accounts for 80%–85% of access loss. The primary patency rate of AV grafts is around 40%–50% at 1 year and 25% at 2 years. Causes of thrombosis include stasis of flow, vascular endothelial injury, and altered blood coagulability, but other contributing factors include arterial stenosis, fistula compression, hematoma formation from cannulation injury, hypovolemia, hypotension, and hypercoagulable states. On physical examination, there is absence of thrill or bruit (Table 8.1). Both endovascular techniques (mechanical and/or pharmacologic) and surgical techniques are effective in declotting the access. In case of recurrent thrombosis, it is important to investigate for causes of thrombosis other than stenosis.

A. Predisposing factors. An increasingly recognized number of dialysis patients have subtle accentuations of hemostasis, including high fibrinogen levels, reduced levels of protein S or C, factor V Leiden mutation, lupus anticoagulant, or elevated hematocrit levels due to erythropoietin therapy. Whether or not these conditions are associated with increased access thrombosis is controversial. Use of warfarin is problematic, because in patients with protein S or C deficiency, or even in the absence of these, warfarin may precipitate calciphylaxis with skin necrosis. Warfarin use is difficult to monitor in patients with lupus anticoagulant, as the prothrombin time is an unreliable measure of anticoagulation.

B. Prevention. Anticoagulants and antiplatelet drugs may help prevent AV access thrombosis, but most studies published thus far do not support their routine use. Separate randomized clinical trials of both low-dose warfarin (with a target international normalized ratio 1.4–1.9) and clopidogrel plus aspirin versus placebo in patients with PTFE grafts failed to demonstrate a reduction in thrombotic events or prolongation of graft survival. Both studies showed clinically and statistically significant bleeding complications in the treated patients. However, another randomized trial found a decrease in the relative risk of thrombosis in patients with new PTFE grafts treated with dipyridamole. A meta-analysis studying the usefulness of antiplatelet therapy to prevent vascular access failure that analyzed 21 eligible trials concluded that antiplatelet agents were useful to protect fistulas from thrombosis or loss of patency, but had little or no effect on the patency of AV grafts (Palmer, 2013).

C. Treatment

1. In AV fistulas. Thrombosis of the fistula occurs either soon after its construction or as a late event. Patients should be taught to monitor their fistula daily, when possible. Early thrombosis results from technical factors and almost always requires surgical or percutaneous intervention, although there may be inadvertent compression while sleeping. Poor flow precedes late thrombosis in most cases, but hypotension or hypercoagulability may also precipitate thrombosis in the absence of downward flow

trends. Treatment of thrombosis can be difficult but should be performed using either percutaneous methods or surgical thrombectomy, depending on the expertise of each institution. Techniques aiming to remove the bulk of the thrombus have been reported to have a higher success rate (Palmer, 2006).

2. **In AV grafts.** Thrombosis can be managed by surgical thrombectomy or by mechanical or pharmacomechanical thrombolysis, again depending on the expertise of the medical center. Treatment should be performed urgently to avoid the need for temporary access. The entire access circuit should be thoroughly evaluated during the procedure by imaging. Residual stenosis exceeding 85% should be retreated by balloon angioplasty or surgical revision. The role of antiplatelet drugs or warfarin in patients with recurrent thrombosis is unknown. Patients who clot with intra-access flows $>1,000$ mL/min should be educated to avoid external access compression, evaluated for hypercoagulability, and/or examined for presence of delayed hypotension after dialysis. Routine monitoring and surveillance of the graft should resume shortly after successful treatment. For patients with failed thrombectomy and thrombolysis, surgical efforts should be focused on creating a secondary fistula from the venous drainage of the graft. Such fistulas are possible because of the venous enlargement and thickening caused by the previous graft, and have the advantage of being usable much sooner after creation of the fistula. KDOQI guidelines recommend that every patient should be evaluated for a secondary fistula after each episode of graft failure.

V. ISCHEMIA IN A LIMB BEARING AN AV ACCESS. Dialysis access–associated hand ischemia, commonly known as “steal syndrome,” complicates 1%–20% of accesses and can lead to pain, loss of function, and, rarely, the loss of limb. One mechanism of hand ischemia is thought to be “arterial steal” from retrograde flow in the distal artery toward the access but the presence of arterial stenosis or distal arteriopathy involving small vessels often are contributory. Risk factors include upper arm access, peripheral arterial disease, and diabetes.

- A. **Detection.** Patients with an established fistula should be assessed monthly by interval history and physical examination. Clinically, there is pain, coldness, and paresthesias of distal extremity, especially during dialysis, which can progress to cyanosis, pulselessness, ischemic ulcers, and dry gangrene over days to weeks to months. The onset can be immediately after access creation or insidiously over days to weeks. Examination requires comparison with the temperature, pulse, and function of the opposite hand.

Digital pressures, transcutaneous oxygen measurements, and arteriography (with access open and closed) are helpful in evaluation, but are not necessarily specific. The diagnosis is based on the clinical symptoms and signs as well as on the demonstration of poor circulation in the extremity. Differential diagnosis involves carpal tunnel syndrome, peripheral vascular disease, neuropathy, nerve trauma, or ischemic monomelic neuropathy due to the loss of blood supply to nerves.

- B. **Management.** Mild ischemia manifested by coldness or paresthesias but without sensory or motor loss can be managed expectantly. Pain of the hand on exercise due to a “steal” effect (or in extreme instances, pain at rest) or the appearance of nonhealing ulcers usually requires surgical intervention. Loss of motor function of hand is a surgical emergency and

surgical evaluation for banding or ligation of the access should be done immediately.

1. **DRIL procedure.** With the usual radiocephalic side-to-side fistula, the radial artery anastomosis regularly steals blood flow from the ulnar artery system. Converting the side-of-artery to an end-of-artery anastomosis can sometimes be used to treat ischemia due to steal. Severe cases of steal syndrome require ligation of the AV fistula, but distal revascularization interval ligation (DRIL) can be used to treat ischemia while preserving fistula patency. The DRIL technique requires ligation of the artery immediately distal to the origin of the AV fistula and construction of a reversed saphenous vein bypass from the artery proximal to the origin of the fistula to the artery distal to the site of ligation. One report suggests that success of the DRIL procedure is higher if the origin of the bypass graft is well upstream to the site of the fistula anastomosis to avoid a region of low pressure in the artery upstream to the fistula anastomotic site (Kopriva, 2014).
2. **Banding.** Steal due to high access flow can be treated by banding, and this can be done using a minimally invasive procedure (Miller, 2010).
3. **Other procedures.** Treatment of hand edema after placement of an AV fistula consists of converting the anastomosis from a side-of-vein to an end-of-vein opening or by selectively tying off affected veins. A small increase in circumference (2–3 cm) of the arm bearing the access is common after placement of an AV access, but larger increases indicate venous hypertension usually due to stenosis of the central veins.

VI. **PSEUDOANEURYSM.** Trauma to AV access from repeated cannulation in the same area can cause damage to all layers of native vein or graft material. Large aneurysms can prevent adequate needle placement and limit potential puncture sites. These dilatations can further expand, especially if there is a downstream stenosis causing increased intra-access pressure. Aneurysms and pseudoaneurysm are prone to get infected or can contribute to thrombosis. A major concern is rupture that can lead to exsanguination and fatal hemorrhage. The signs of impending rupture include thin and shiny overlying skin, prolonged leaking or ulceration over the surface, and rapid enlargement of aneurysm. Early intervention is essential to prevent such complications.

- A. **AV fistula.** Pseudoaneurysm is much more common than a true aneurysm. It results from failure to properly rotate access puncture sites, from inadequate hemostasis and from extravasation of blood following dialysis needle removal. Most pseudoaneurysms and true aneurysms are treated by observation only and by avoiding puncture of the fistula in the area of the aneurysm site, though sometimes surgical correction is required.
- B. **AV graft.** In AV grafts, there is no true expansion of the vessel lumen; the wall of the “aneurysm,” really a pseudoaneurysm, is formed by a layer of external soft tissue. These should be treated by resection and insertion of an interposition graft if they are rapidly expanding, >12 mm in diameter, and/or threatening the viability of the overlying skin. The AV graft should be surgically revised if pseudoaneurysm formation limits the number of puncture sites available or is causing persistent symptoms such as pain and throbbing.
- C. **Use of stents.** Stents have been used for the percutaneous treatment of pseudoaneurysms (Fotiadis, 2014). Although these devices result in immediate exclusion of pseudoaneurysm, recurrence of the pseudoaneurysm and stent-graft damage as a result of repeated

cannulation remain major problems. Broken stent struts can sometimes protrude through the skin, posing a threat of injury to staff who place the patient on dialysis. Exclusion of a pseudoaneurysm using a stent graft represents an “off-label” use of the device. The risk of stent-graft infection is another consideration. Safety of cannulation through stent grafts used to treat pseudoaneurysm has not been conclusively established in a prospective manner. Similarly, the role of surgical intervention in the treatment of pseudoaneurysms has not been directly compared with results using stent grafts. Stent grafts do provide rescue therapy in the event of angioplasty-induced vascular rupture. Complete rupture is one situation in which a stent graft is clearly indicated as this stabilizes the access and avoids the need for an emergency surgical procedure.

VII. INFECTIONS. Infection of the access is usually manifested as erythema, pain, or purulent exudate from needle sites. Often, the first sign is fever with no other obvious source and positive blood cultures. The access should not be used if actively infected. Cultures (of blood and of any wound if present) should be taken and antibiotic therapy initiated. The possibility of endocarditis or other sources of infection should be investigated, depending on the pathogen found, and especially if cultures fail to turn negative after antibiotic treatment. Ultrasound evaluation of the tissues around the access is sometimes useful in revealing localized fluid accumulation. An infected access usually requires surgical intervention for debridement or excision.

A. **AV fistula.** Infections are rare and usually caused by staphylococci; they should be treated in the same manner as subacute endocarditis with 6 weeks of antibiotics. Diagnosis is based on local signs of inflammation. Prompt therapy with antistaphylococcal antimicrobials, after local and blood cultures have been obtained, is often curative. Septic embolus during therapy warrants removal of the fistula.

B. **AV graft.** Graft infection occurs eventually in 5%–20% of grafts placed, and thigh grafts have an even higher rate of infection. Prophylactic antimicrobials should be used when patients with vascular grafts undergo procedures capable of inducing bacteremia, such as dental extraction or genitourinary manipulation. Most graft infections are staphylococcal. Gram-negative organisms such as *Escherichia coli* may be cultured, especially from thigh grafts (Harish and Allon, 2011). Initial antibiotic treatment should include drugs active against gram-negative and gram-positive organisms as well as against *Enterococcus*. Local infection of a graft can be treated with antibiotics (based on culture results) and by incision/resection of the infected portion. Extensive infection requires complete excision/removal.

Septicemia may occur without local signs. In such cases, a technetium-labeled leukocyte scan may help reveal a graft infection, but care must be taken to remove any blood-soaked dressings prior to scanning, as they may lead to a falsely positive result. Hemorrhage may occur due to rupture of an infected graft. A graft that becomes infected within 30 days of placement probably should be removed.

1. **Silent infection in a thrombosed AV graft.** Old thrombosed grafts may become infected with few local signs, suggesting that perhaps such grafts should be electively removed soon after they are abandoned. This can be a cause of elevated serum C-reactive protein

levels and ESA resistance. However, because surgical removal often requires extensive tissue dissection, this problem needs further study before a blanket recommendation can be made.

VIII. CONGESTIVE HEART FAILURE. Congestive heart failure is unusual with a forearm access but may occur in patients with upper arm or femoral fistulas, particularly if there is coexistent heart disease. Although long-term cardiac function is thought to be generally unaffected by the presence of an AV access, closure of access has been associated with reduction of left ventricular mass and improvement in left ventricular eccentric and concentric hypertrophy (Movilli, 2010). Increased pulmonary arterial flow (which can be associated with a high-flow access) can aggravate pulmonary hypertension.

Some AV accesses can continue to increase their blood flow. There is a higher risk of high output heart failure when the flow exceeds 20% of the cardiac output. Upper arm access and access flow >2,000 mL/min increase such risk (Stern and Klemmer, 2011). In these cases, banding of access to reduce access flow (Miller, 2010) should be considered. Despite theoretical benefits, surgical narrowing or banding should be considered primarily when cardiac studies have shown marked changes in cardiac output following transient occlusion of the access. In patients with unexplained high cardiac output states, one should first consider and correct any anemia that may be present. Use of vasodilators such as minoxidil or hydralazine without concomitant beta-blockade is another common, correctable cause of high cardiac output. Finally, volume overload is common in dialysis patients and must be considered in individuals presenting with signs and symptoms of heart failure.

IX. COMPLICATION OF PERCUTANEOUS INTERVENTIONS. The most frequent procedure-related complication seen in association with angioplasty is vessel rupture as evidenced by contrast extravasation and/or bleeding. This complication is relatively infrequent (2%), and can range from clinically insignificant to severe. Subclinical extravasation of contrast at the site of angioplasty is not usually a cause for much concern. In mild cases of vessel rupture, there may be hematoma, but the patient is asymptomatic. Larger hematomas may affect access flow, and very large hematomas can result from total or near total rupture of the access vein. In such instances, insertion of an endovascular stent can be very helpful to stem the bleeding.

Another complication that is associated with percutaneous angioplasty is pulmonary embolism, especially during thrombectomy. Clinically significant pulmonary embolism is infrequent. Distal embolization of thrombus into an artery can occur during thrombectomy, and in such cases, the thrombus should be immediately removed using an embolectomy catheter.

X. CLINICAL OUTCOME GOALS AND MONITORING

A. Establishment of a vascular access team and continuous quality improvement (CQI).

Establishment of a vascular access team that includes nephrologists, surgeons, interventionists, a vascular access coordinator, and dialysis personnel is essential to ensure good vascular access outcomes. Ideally, the vascular access team should meet regularly to review data and provide a measurement of performance based on established KDOQI guidelines. Data collected should include number and type of vascular accesses,

infection and thrombosis rates, number and type of interventions performed, and time to access failure. Centers should monitor outcome results after thrombosis and set minimum goals for both immediate and long-term patency. Trends should be analyzed and feedback provided to all members of the team. This approach fosters preemptive action and salvage rather than replacement of AV accesses, and helps ensure a minimal need for venous catheter access, and delivery of an adequate dialysis dose.

References and Suggested Readings

- Agarwal AK, Asif A. *Interventional Nephrology*. Washington, DC: American Society of Nephrology, NephSAP; 2009.
- Asif A, et al., eds. *Textbook of Interventional Nephrology*. New York, NY: McGraw Hill; 2012.
- Ayus AC, Sheikh-Hamad D. Silent infections in clotted hemodialysis access grafts. *J Am Soc Nephrol*. 1998;9:1314–1317.
- Badr B, et al. Transonic, thermodilution, or ionic dialysance to manage vascular access: which method is best? *Hemodial Int*. 2014;18:127–135.
- Beathard GD. A practitioner's resource guide to physical examination of the vascular access. ESRD Network of Texas; 2012. <http://www.esrdnet15.org/QI/C5D.pdf>.
- Besarab A, et al. Simplified measurement of intra-access pressure. *ASAIO J*. 1996;42:M682–M687.
- Besarab A, et al. The utility of intra-access monitoring in detecting and correcting venous outlet stenoses prior to thrombosis. *Kidney Int*. 1995;47:1364–1373.
- Besarab A, Sherman R. The relationship of recirculation to access blood flow. *Am J Kidney Dis*. 1997;29:223–229.
- Campos RP, et al. Stenosis in hemodialysis arteriovenous fistula: evaluation and treatment. *Hemodial Int*. 2006;10:152–161.
- Chemla ES, et al. Complex bypasses and fistulas for difficult hemodialysis access: a prospective, single-center experience. *Semin Dial*. 2006;19:246–250.
- Chin AI, et al. Intra-access blood flow in patients with newly created upper-arm arteriovenous native fistulas for hemodialysis access. *Am J Kidney Dis*. 2004;44:850–858.
- Coca SG, Perazella MA. Use of iodinated and gadolinium-containing contrast media. In: Daugirdas JT, ed. *Handbook of Chronic Kidney Disease Management*. Philadelphia, PA: Kluwer; 2011:363–375.
- Coentrão L, Faria B, Pestana M. Physical examination of dysfunctional arteriovenous fistulae by non-interventionalists: a skill worth teaching. *Nephrol Dial Transplant*. 2012;27:1993–1996.
- Crowther MA, et al. Low-intensity warfarin is ineffective for prevention of PTFE graft failure in patients on hemodialysis: a randomized controlled trial. *Am J Soc Nephrol*. 2002;13(9):2331–2337.
- Depner TA, Krivitsky NM, MacGibbon D. Hemodialysis access recirculation measured by ultrasound dilution. *ASAIO J*. 1995;41:M749–M753.
- Fontseré N, et al. Practical utility of on-line clearance and blood temperature monitors as noninvasive techniques to measure hemodialysis blood access flow. *Blood Purif*. 2011;31:1–8.
- Fotiadis N, et al. Endovascular repair of symptomatic hemodialysis access graft pseudoaneurysms. *J Vasc Access*. 2014;15:5–11.
- Gradzki R, et al. Use of ACE inhibitors is associated with prolonged survival of arteriovenous grafts.

Am J Kidney Dis. 2001;38:1240–1244.

- Harish A, Allon M. Arteriovenous graft infection: a comparison of thigh and upper extremity grafts. *Clin J Am Soc Nephrol.* 2011;6:1739–1743.
- Haskal ZJ, et al. Stent graft versus balloon angioplasty for failing dialysis access grafts. *N Engl J Med.* 2010;362:494–503.
- Huijbregts HJ, Blankestijn PJ. Dialysis access—guidelines for current practice. *Eur J Vasc Endovasc Surg.* 2006;31:284–287.
- Jiang SH, et al. Validation of the measurement of haemodialysis access flow using a haemoglobin dilution test. *Blood Purif.* 2011;32:48–52.
- Kaufman JS, et al. Randomized controlled trial of clopidogrel plus aspirin to prevent hemodialysis access graft thrombosis. *J Am Soc Nephrol.* 2003;14:2313–2321.
- Kopriva D, McCarville DJ, Jacob SM. Distal revascularization and interval ligation (DRIL) procedure requires a long bypass for optimal inflow. *Can J Surg.* 2014;57:112–115.
- Krivitski NM. Theory and validation of access flow measurement by dilution technique during hemodialysis. *Kidney Int.* 1995;48:244–250.
- Kumbar L, Karim J, Besarab A. Surveillance and monitoring of dialysis access. *Int J Nephrol.* 2012;2012:649735.
- Lok CE, et al. Reducing vascular access morbidity: a comparative trial of two vascular access monitoring strategies. *Nephrol Dial Transplant.* 2003;18:1174–1180.
- Maya ID, et al. Vascular access stenosis: comparison of arteriovenous grafts and fistulas. *Am J Kidney Dis.* 2004;44:859–865.
- Miller GA, et al. The MILLER banding procedure is an effective method for treating dialysis-associated steal syndrome. *Kidney Int.* 2010;77:359–366.
- Mohan S, et al. Effective ionic dialysance/blood flow rate ratio: an indicator of access recirculation in arteriovenous fistulae. *ASAIO J.* 2010;56:427–433.
- Movilli E, et al. Long-term effects of arteriovenous fistula closure on echocardiographic functional and structural findings in hemodialysis patients: a prospective study. *Am J Kidney Dis.* 2010;55:682–689.
- National Kidney Foundation. K/DOQI clinical practice guidelines for vascular access: update 2006. *Am J Kidney Dis.* 2006;48(suppl 1):S188–S306.
- Oakes DD, et al. Surgical salvage of failed radiocephalic arteriovenous fistulas: techniques and results in 29 patients. *Kidney Int.* 1998;53:480–487.
- Ohira S, Kon T, Imura T. Evaluation of primary failure in native AV-fistulae (early fistula failure). *Hemodial Int.* 2006;10:173–179.
- Ortega T, et al. The timely construction of arteriovenous fistulas: a key to reducing morbidity and mortality and to improving cost management. *Nephrol Dial Transplant.* 2005;20:598–603.
- Palmer RM, et al. Is surgical thrombectomy to salvage failed autogenous arteriovenous fistulae worthwhile? *Am Surg.* 2006;72:1231–1233.
- Palmer SC, et al. Antiplatelet therapy to prevent hemodialysis vascular access failure: systematic review and meta-analysis. *Am J Kidney Dis.* 2013;61:112–122.
- Paulson WD, Moist L, Lok CE. Vascular access surveillance: an ongoing controversy. *Kidney Int.* 2012;81:132–142.
- Rayner HC, et al. Vascular access results from the Dialysis Outcomes and Practice Patterns Study

(DOPPS): performance against Kidney Disease Outcomes Quality Initiative (K/DOQI) Clinical Practice guidelines. *Am J Kidney Dis*. 2004;44 (5 suppl 3):22–26.

Roca-Tey R, et al. Five years of vascular access stenosis surveillance by blood flow rate measurements during hemodialysis using the Delta-H method. *J Vasc Access*. 2012;13:321–328.

Saran R, et al. Association between vascular access failures and the use of specific drugs: the Dialysis Outcomes and Practice Patterns Study (DOPPS). *Am J Kidney Dis*. 2002;40:1255–1263.

Sessa C, et al. Treatment of hand ischemia following angioaccess surgery using the distal revascularization interval-ligation technique with preservation of vascular access: description of an 18-case series. *Ann Vasc Surg*. 2004;18:685–694.

Stern AB, Klemmer PJ. High-output heart failure secondary to arteriovenous fistula. *Hemodial Int*. 2011;15:104–107.

Tessitore N, et al. Clinical access assessment. *J Vasc Access*. 2014;15(suppl 7):20–27.

Tordoir J, et al. EBPG on vascular access. *Nephrol Dial Transplant*. 2007;22(suppl 2): ii88–ii117.

White JJ, et al. Paulson relation between static venous pressure (VP), hemodialysis graft blood flow (Q), and stenosis: analysis by fluid mechanics model [Abstract]. *J Am Soc Nephrol*. 2005;16:F-PO531.

Zasuwa G, et al. Automated intravascular access pressure surveillance reduces thrombosis rates. *Semin Dial*. 2010;23:527–535.

Web References

An excellent teaching guide, introduction to vascular access, with pictures of anatomy, etc. <http://www.fistulafirst.org/atlas/index.html>.

Information on interventional nephrology, annual meetings, credentialing, publications, and statement papers. <http://www.asdin.org>.

9

Venous Catheter Infections and Other Complications

Loay Salman, Arif Asif,
and Michael Allon

The main problems associated with venous catheters are infection, poor flow, thrombosis, and central venous stenosis.

- I. **INFECTION.** Despite the best practices detailed in Chapter 7 (Table 7.3), infections do occur with venous catheters, and at a rate substantially higher than with arteriovenous (AV) fistulas. Infection is the leading cause of catheter loss and increases morbidity and mortality. Most often, infection results from contamination of the catheter connectors or from lumen contamination during dialysis or from infused solutions. Infection also may arise from the migration of the patient's own skin flora through the puncture site and onto the outer catheter surface. Catheters can sometimes become colonized from more remote sites during bacteremia.
 - A. **Exit-site infection** can be diagnosed when there is erythema, discharge, crusting, and tenderness at the skin exit site, but no tunnel tenderness or purulence. Treatment with topical antibiotic cream and oral antibiotics may be sufficient. These infections can be prevented by meticulous exit-site care. The patient should be investigated for nasal carriage of *Staphylococcus* and if present, treated with intranasal mupirocin cream (half tube twice a day to each nostril for 5 days) to prevent future infections. With exit-site infection, the catheter must be removed if systemic signs of infection develop (leukocytosis or temperature $>38^{\circ}\text{C}$), if pus can be expressed from the track of the catheter, or if the infection persists or recurs after an initial course of antibiotics. If blood cultures are positive, then the catheter should be removed.
 - B. **Tunnel infection** is infection along the subcutaneous tunnel extending proximal to the cuff toward the insertion site and venotomy. Typically, there is marked tenderness, swelling, and erythema along the catheter tract in association with purulent drainage from the exit site. This can result in systemic bacteremia. In the presence of drainage or signs of systemic infection, the catheter should be removed immediately and antibiotic therapy prescribed.
 - C. **Catheter-related bloodstream infection (CRBSI).** Patients present with signs and symptoms of systemic infection, which may range from minimal to severe. Milder cases present with fever or chills, whereas more severe cases exhibit hemodynamic instability. Patients may develop septic symptoms after initiation of dialysis, suggesting systemic release of bacteria and/or endotoxin from the catheter. There can be signs of metastatic

infection, including endocarditis, osteomyelitis, epidural abscess, and septic arthritis. Gram-positive organisms are the causative organisms in the majority of cases, but gram-negative infections occur in a very sizeable minority. For details on how to treat CRBSI in dialysis patients, caregivers can refer to valuable information available on the dialysis section of the U.S. Centers of Disease Control (CDC) website (<http://www.cdc.gov/dialysis>), the NKF KDOQI 2006 vascular access guidelines (NKF, 2006), the European Renal Best Practices (ERBP) access guidelines (Tordoir, 2007), the Infectious Disease Society of North America (IDSA) guidelines update for management of CRBSI (Mermel, 2009), and the ERBP commentary on the IDSA guidelines (Vanholder, 2010). Treatment algorithms and tips from the IDSA are reproduced in Figure 9.1 and Tables 9.1 and 9.2, and key recommendations from the ERBP are shown in Figure 9.2.

The principles of CRBSI management in dialysis patients are different from the infectious disease guidelines for treatment of infection in short-term central venous catheters. In hemodialysis, the venous catheter is a lifeline that sometimes can be replaced only with great difficulty. Thus, the guidelines include a variety of catheter salvage maneuvers, which involve use of antibiotic-containing catheter locks or replacing the infected catheter with a new catheter in the same location over a guidewire. However, these catheter salvage techniques should be used only in limited, defined circumstances. If a patient's condition worsens after a relatively short trial of catheter salvage, the catheter must be removed to minimize the risk of spreading the infection to body organs.

1. **Blood and catheter tip cultures.** In working up a suspected CRBSI, cultures can be obtained from the catheter hub, from a peripheral vein, or from the blood lines during dialysis treatment. The IDSA recommendations are to take blood cultures from a catheter hub and from a peripheral vein and, when a catheter has been removed because of suspicion of infection, to also culture the distal 5 cm of its tip. One is looking for both blood cultures or for both the blood culture and a catheter tip culture to be positive with the same organism to confirm a diagnosis of CRBSI. When taking cultures from the skin or from a catheter hub, the IDSA recommends cleaning and sterilizing the area with alcoholic chlorhexidine rather than povidone-iodine, and allowing the antiseptic to dry before sampling; this avoids contamination of the cultured material with liquid antiseptic. The IDSA guidelines recognize that obtaining blood from the dialysis bloodline is an acceptable substitute for peripheral blood cultures in many hemodialysis patients.

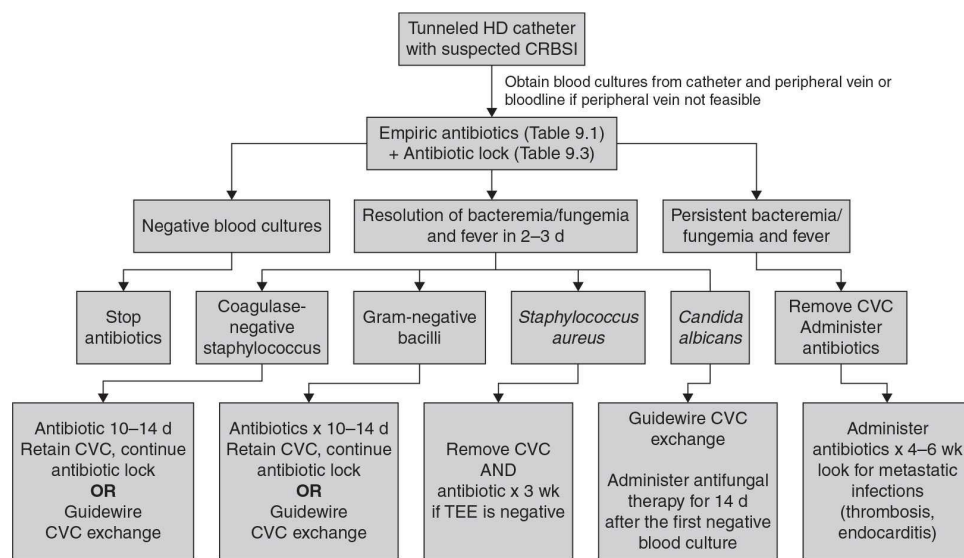

FIGURE 9.1 Pathway for treatment of cuffed hemodialysis catheter infections according to the Infectious Disease Society of America, 2009 Update. HD, hemodialysis; CVC, central venous (dialysis) catheter; TEE, transesophageal echocardiography. (Reproduced with permission from Mermel LA, et al. Clinical practice guidelines for the diagnosis and management of intravascular catheter-related infection: 2009 update by the Infectious Diseases Society of America. *Clin Infect Dis.* 2009;49:1–45.)

TABLE

9.1

Antibiotic Dosing for Patients Who Are Undergoing Hemodialysis

Empirical Antibiotic Dosing Pending Culture Results

Vancomycin plus empirical gram-negative rod coverage based on local antibiogram data

OR

Vancomycin plus gentamicin

Typical doses: (Doses need to be adjusted for residual renal function and for enhanced dialytic removal in case of frequent or extended dialysis, very high efficiency, high-flux treatments, or hemodiafiltration. Monitor predialysis trough levels if possible)

(Cefazolin may be used in place of vancomycin in units with a low prevalence of methicillin-resistant staphylococci)

Vancomycin: 20-mg/kg loading dose infused during the last hour of the dialysis session, and then 500 mg during the last 30 min of each subsequent dialysis session

Gentamicin (or tobramycin): 1 mg/kg, not to exceed 100 mg after each dialysis session

Ceftazidime: 1 g iv after each dialysis session

Cefazolin: 20 mg/kg iv after each dialysis session

For Candida Infection

An echinocandin (caspofungin 70 mg iv loading dose followed by 50 mg iv daily; intravenous micafungin 100 mg iv daily; or anidulafungin 200 mg iv loading dose, followed by 100 mg iv daily); fluconazole (200 mg orally daily); or amphotericin B

iv, intravenous.

Adapted from Mermel LA, et al. Clinical practice guidelines for the diagnosis and management of intravascular catheter-related infection: 2009 update by the Infectious Diseases Society of America. *Clin Infect Dis*. 2009;49:1–45, with permission.

The ERBP ad hoc advisory recommendations are similar to what the IDSA recommends. They too, recognize the difficulties in obtaining cultures from peripheral veins in hemodialysis patients, and believe that a practical alternative is to simply draw blood cultures from the dialysis circuit. Blood from the circuit during dialysis probably represents peripheral blood rather than localized catheter blood, and so a positive blood culture drawn from the bloodline may reflect a source of bacteremia other than at the catheter. The ERBP group suggests that the best way to deal with this possibility is by evaluating clinical history, examination, imaging, and targeted laboratory testing, including urine culture if possible.

2. **Indications for immediate catheter removal.** If there is evidence of septic thrombosis, endocarditis, or osteomyelitis, or of severe sepsis with hypotension, then the dialysis catheter needs to be removed immediately. The same recommendation generally holds for tunnel infection with fever. Dialysis should be continued with a temporary catheter inserted at a different location.

TABLE

9.2

Unique Aspects of Managing Patients Receiving Hemodialysis through Catheters for Whom Catheter-Related Infection Is Suspected or Proven

Blood and Catheter Cultures

Peripheral blood samples should be obtained for culture from vessels that are not intended for future use in creating a dialysis fistula (e.g., hand veins).

When a peripheral blood sample cannot be obtained, blood samples may be drawn during hemodialysis from bloodlines connected to the dialysis catheter.

In patients with suspected CRBSI for whom blood cultures have been obtained and for whom antibiotic therapy has been initiated, antibiotic therapy can be discontinued if both sets of blood cultures have negative results and no other source of infection is identified.

When a peripheral blood sample cannot be obtained, no other catheter is in place from which to obtain an additional blood sample, there is no drainage from the insertion site available for culture, and there is no clinical evidence for an alternate source of infection, then positive results of culture performed on a blood sample obtained from a catheter should lead to continuation of antimicrobial therapy for possible CRBSI in a symptomatic hemodialysis patient.

Catheter Removal, Change, and Salvage with Antimicrobial Lock

The infected catheter should always be removed for patients with hemodialysis CRBSI due to *S. aureus*, *Pseudomonas* sp., or *Candida* sp. and a temporary (nontunneled catheter) should be inserted into another anatomical site. If absolutely no alternative sites are available for catheter insertion, then exchange the infected catheter over a guidewire.

When a hemodialysis catheter is removed for CRBSI, a long-term hemodialysis catheter can be placed once blood cultures with negative results are obtained.

For hemodialysis CRBSI due to other pathogens (e.g., gram-negative bacilli other than *Pseudomonas* sp. or coagulase-negative staphylococci), a patient can initiate empirical intravenous antibiotic therapy without immediate catheter removal. If the symptoms persist or if there is evidence of a metastatic infection, the catheter should be removed. If the symptoms that prompted initiation of antibiotic therapy (fever, chills, hemodynamic instability, or altered mental status) resolve within 2–3 d and there is no metastatic infection, then the infected catheter can be exchanged over a guidewire for a new, long-term hemodialysis catheter.

Alternatively, for patients for whom catheter removal is not indicated (i.e., those with resolution of symptoms and bacteremia within 2–3 d after initiation of systemic antibiotics and an absence of metastatic infection), the catheter can be retained, and an antibiotic lock can be used as adjunctive therapy after each dialysis session for 10–14 d.

Antibiotic Therapy

Empirical antibiotic therapy should include vancomycin and coverage for gram-negative bacilli, based on the local antibiogram (e.g., third-generation cephalosporin, carbapenem, or beta-lactam/beta-lactamase combination)

Patients who receive empirical vancomycin and who are found to have CRBSI due to methicillin-susceptible *S. aureus* should be switched to cefazolin. For cefazolin, use a dosage of 20 mg/kg (actual body weight), rounded to the nearest 500-mg increment, after dialysis.

A 4–6-wk antibiotic course should be administered if there is persistent bacteremia or fungemia (i.e., 172 hr in duration) after hemodialysis catheter removal or for patients with endocarditis or suppurative thrombophlebitis, and 6–8 wk of therapy should be administered for the treatment of osteomyelitis in adults.

Patients receiving dialysis who have CRBSI due to vancomycin-resistant enterococci can be treated with either daptomycin (6 mg/kg after each dialysis session) or oral linezolid (600 mg every 12 hr).

Antibiotic Locks

Antibiotic lock is indicated for patients with CRBSI involving long-term catheters with no signs of exit-site or tunnel infection for whom catheter salvage is the goal.

For CRBSI, antibiotic lock should not be used alone; instead, it should be used in conjunction with systemic antimicrobial therapy, with both regimens administered for 7–14 d.

Dwell times for antibiotic lock solutions should generally not exceed 48 hr before reinstallation of lock solution; preferably, reinstallation should take place every 24 hr for ambulatory patients with femoral catheters. However, for patients who are undergoing hemodialysis, the lock solution can be renewed after every dialysis session.

Catheter removal is recommended for CRBSI due to *S. aureus* and *Candida* sp., instead of treatment with antibiotic lock and catheter retention, unless there are unusual extenuating circumstances (e.g., no alternative catheter insertion site).

For patients with multiple positive catheter-drawn blood cultures that grow coagulase-negative staphylococci or gram-negative bacilli and concurrent negative peripheral blood cultures, antibiotic lock therapy can be given without systemic therapy for 10–14 d.

For vancomycin, the concentration should be at least 1000 times higher than the MIC of the microorganism involved.

At this time, there are insufficient data to recommend an ethanol lock for the treatment of CRBSI.

Follow-up Cultures

It is not necessary to confirm negative culture results before guidewire exchange of a catheter for a patient with hemodialysis-related CRBSI if the patient is asymptomatic.

Surveillance blood cultures should be obtained 1 wk after completion of an antibiotic course for CRBSI if the catheter has been retained. If the blood cultures have positive results, the catheter should be removed, and a new, long-term dialysis catheter should be placed after additional blood cultures are obtained that have negative results.

Reproduced from: Mermel LA, et al. Clinical practice guidelines for the diagnosis and management of intravascular catheter-related infection: 2009 update by the Infectious Diseases Society of America. *Clin Infect Dis*. 2009;49:1–45.

3. **Choice of antibiotic.** Gram-positive organisms, primarily *Staphylococcus* spp., are the most common, but gram-negative organisms may be isolated in up to 40% of cases. Broad-spectrum antibiotic therapy should be started immediately after drawing cultures. Dialysis units should keep a database of all CRBSI, including causative organisms, their susceptibility, and response to therapy, as this information is extremely valuable in guiding antibiotic therapy for new cases. If methicillin-resistant *Staphylococcus* is known to be common in the local hemodialysis population, the initial therapy should include vancomycin, rather than a first-generation cephalosporin. Adequate empiric gram-negative coverage can be provided with either an aminoglycoside or a third-generation cephalosporin. However, aminoglycosides may cause ototoxicity in up to 20% of hemodialysis patients. If treatment was begun for methicillin-resistant *Staphylococcus* and the culture shows a methicillin-sensitive organism, the treatment should be changed to cefazolin or a similar antibiotic.

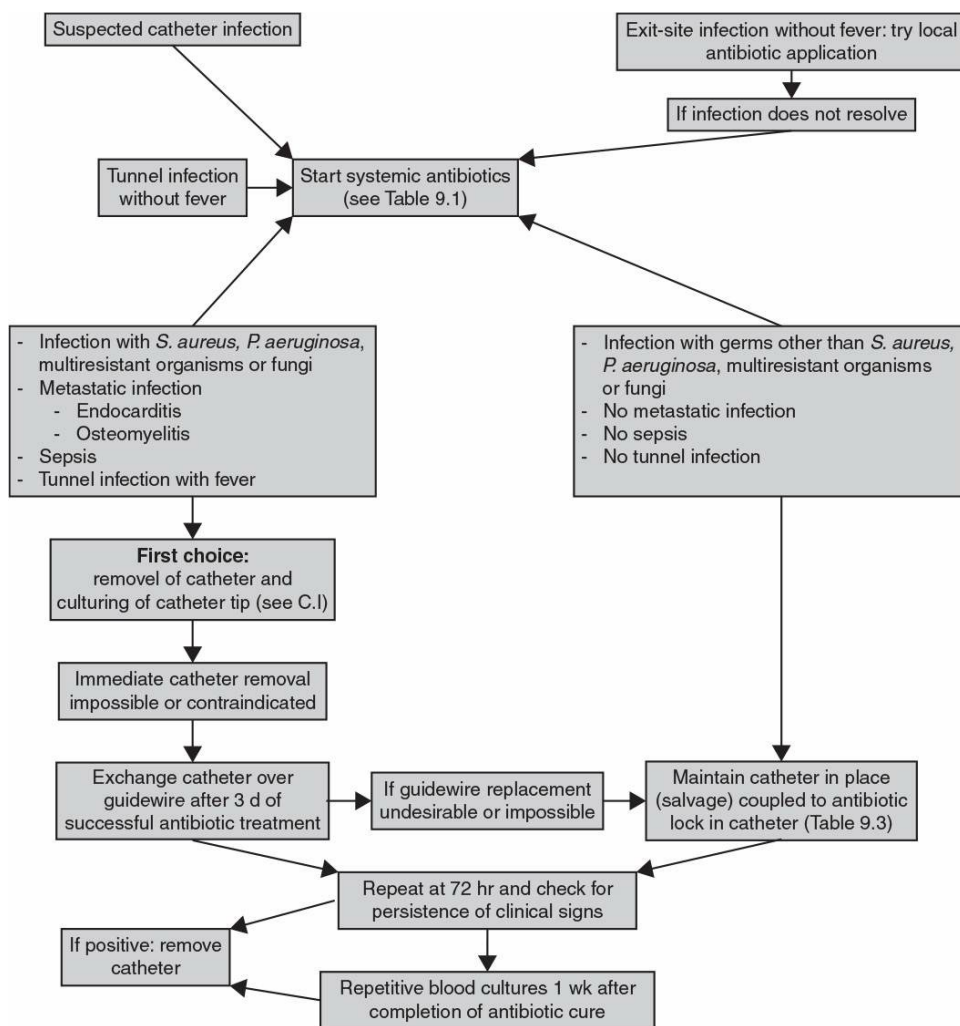

FIGURE 9.2 Pathway for treatment of cuffed hemodialysis catheter infections according to the European Best Practices Group, 2010 Update. (Adapted with permission from Vanholder R, et al. Catheter-related blood stream infections (CRBSI): a European view. *Nephrol Dial Transplant*. 2010;25:1753–1756.)

4. **Dose of antibiotic.** It is practical to use antibiotics that can be given at the end of each dialysis session and maintain desired blood levels during the interdialytic interval. Some initial doses are given in Tables 9.1 and 9.2 (from the IDSA, Mermel, 2009). However, these doses may need to be increased in patients with substantial residual kidney function or those receiving intensive dialysis treatments such as frequent dialysis, high-intensity hemodiafiltration, or continuous renal replacement therapy. Where possible, predialysis trough drug levels should be monitored, but this is usually practical only in the inpatient setting. The strategy of dosing antibiotics in hemodialysis and patients undergoing continuous renal replacement therapy is discussed in more detail in Chapters 15 and 35, and detailed dosing regimens can be found in Mermel (2009).
5. **Duration of treatment and course.** Antibiotics should be discontinued promptly if the original blood cultures had no growth and the patient's symptoms are consistent with absence of infection. In the event of positive cultures, the initially chosen antibiotic regimen should be adjusted once bacterial sensitivities are available. A 2–3-week course of systemic antibiotics is adequate in uncomplicated cases of catheter-related

bacteremia. A longer course (4–8 weeks) is indicated if there is a metastatic infection, such as endocarditis or osteomyelitis (see Figure 9.1 and Table 9.2).

6. **Catheter removal and exchange over a guidewire.** From an infectious disease perspective, the catheter is always best removed whenever a CRSBI occurs, regardless of the causal organism. However, since the patient will continue to require dialysis support, placement of a temporary catheter becomes necessary. Thus, the decision to remove the catheter should be individualized on the basis of the severity of sepsis and availability of alternative venous access sites. If the patient is clinically septic and unstable despite administration of systemic antibiotics, the catheter should be removed as soon as possible. Attempts to maintain the same catheter by treating through the infection have not been successful, with a success rate of <30% and with the risk of metastatic infections. However, several studies support the use of guidewire exchange in patients whose symptoms resolve within 2–3 days of initiating intravenous antibiotics, reporting a 70%–80% catheter salvage and cure. Thus, removing the infected catheter (and with it presumably the biofilm harboring the bacteria) and replacing it with a new catheter through the same venotomy preserves the venous access site while curing the infection. Guidewire replacement should be done only if the symptoms that prompted initiation of antibiotic treatment have resolved over a period of 2–3 days of initial antibiotic therapy and there is no evidence of metastatic infection.

- a. **Catheter infection with *Staphylococcus aureus*, *Pseudomonas* sp., or *Candida* sp.**
When the initial infection is with one of these organisms, both the IDSA and ERBP recommend removal of the catheter as soon as this is known. Exchange of the catheter over a guidewire or attempts at catheter lock salvage (see what follows) are not recommended with these infecting organisms unless extenuating circumstances are present.

7. **Antibiotic locks to treat established catheter infection.** Another approach to treatment of patients with catheter-related bacteremia is to instill a concentrated antibiotic lock into the catheter lumen at the end of each dialysis session, as an adjunct to systemic antibiotics (Table 9.3). The antibiotic lock is used only for the duration of systemic antibiotics, after which a standard heparin or citrate lock is resumed. In about two-thirds of cases, the antibiotic lock successfully sterilizes the catheter biofilm, thereby permitting successful treatment of the bacteremia while salvaging the infected catheter. In the remaining one-third of cases, the patient has persistent fever or positive surveillance cultures, in which case prompt catheter replacement is indicated. The antibiotic lock protocol is most commonly successful in catheter-related bacteremia due to *Staphylococcus epidermidis* (75%) or gram-negative infections (87%), and less often successful in *S. aureus* infections (40%) (Allon, 2004; Poole, 2004), for which it is not recommended. There is a large amount of leakage from the solution instilled into a catheter lock over 24 hours (Sungur, 2007; Schilcher, 2014). For this reason, the concentration of antibiotic in the lock must be substantially higher than the minimal inhibitory concentration of the organism being targeted. Usually, the lock solution also contains either 2,500 or 5,000 IU/mL heparin or is mixed with 4% sodium citrate.

Amikacin 25 mg/mL
Amphotericin B 2.5 mg/mL
Ampicillin 10 mg/mL
Cefazolin 5 mg/mL
Cefazolin 5 mg/mL plus gentamicin 1 mg/mL
Ceftazidime 5 mg/mL
Ciprofloxacin 0.2 mg/mL
Daptomycin 5 mg/mL
Linezolid 1 mg/mL
Gentamicin 1 mg/mL
Gentamicin 1 mg/mL plus vancomycin 2.5 mg/mL
Vancomycin 2.5–5.0 mg/mL ^b

^aThese can be mixed with heparin, 2,500 or 5,000 IU/mL, or with 4% citrate.

^bVancomycin at 20 mg/mL showed signs of incompatibility with 4% sodium citrate.

Mermel LA, et al. Clinical practice guidelines for the diagnosis and management of intravascular catheter-related infection: 2009 update by the Infectious Diseases Society of America. *Clin Infect Dis*. 2009;49:1–45; Joshi AJ, Hart PD. Antibiotic catheter locks in the treatment of tunneled hemodialysis catheter-related blood stream infection. *Semin Dial*. 2013;26:223–226; Dotson B, et al. Physical compatibility of 4% sodium citrate with selected antimicrobial agents. *Am J Health Syst Pharm*. 2010;67:1195–1198.

8. **Follow-up blood cultures.** Surveillance blood cultures normally are obtained after 72 hours of treatment, depending on the patient's clinical course. Also, it is important to obtain follow-up blood cultures 1 week after the planned treatment course has finished to confirm that there has not been a recurrence of infection.

D. **Complications of CRBSI.** Delay in therapy or prolonged attempts to salvage an infected cuffed catheter can lead to serious complications, including endocarditis, osteomyelitis, suppurative thrombophlebitis, and spinal epidural abscess. The last is a rare but serious neurologic complication in hemodialysis patients. In one series, 50% of cases of spinal epidural abscess were associated with attempted salvage of an infected cuffed venous catheter (Kovalik, 1996). Presenting complaints are fever, backache, local spinal tenderness, leg pain and weakness, sphincter dysfunction, paresis, and/or paralysis. For diagnosis, magnetic resonance imaging appears to be less sensitive than computed tomography–myelography. Plain computed tomographic scanning without myelography has low sensitivity and can give misleading results (e.g., disc protrusion). Early (immediate) decompressive surgery is usually advised, although rarely patients can be successfully

treated with antibiotics only.

Endocarditis should be suspected in patients in whom fever and bacteremia persist despite appropriate antibiotics and catheter removal. This complication is seen most commonly in the setting of *S. aureus* bacteremia. Signs include development of symptomatic heart failure and a new heart murmur. A transthoracic or transesophageal echocardiogram confirms the presence of valvular vegetations and insufficiency.

- E. **Aspirin.** Aspirin treatment has been reported to be associated with a reduced incidence of *S. aureus*-related CRBSI (Sedlacek, 2007). Prior aspirin use also has been associated with reduced symptoms of infection and size of vegetations on cardiovascular implantable electronic devices (Habib, 2013). This finding needs to be confirmed, and use of aspirin to limit infection incidence in tunneled venous catheters is not recommended by guideline groups at this time.

II. **POOR CATHETER FLOW (CATHETER DYSFUNCTION).** Catheter dysfunction can be defined as a failure to deliver a blood flow rate of at least 300 mL/min at a prepump pressure that is less negative than -250 mm Hg. Associated problems are inability to aspirate blood freely from the catheter lumens, and frequent pressure alarms not responsive to patient repositioning or catheter flushing.

- A. **Initial (early) dysfunction.** Recently placed catheters can have poor flow due to a kink, compression within the catheter tunnel from edema, malposition with the catheter having been inserted into the azygous or hemiazygous veins, or improper tip placement (Figure 9.3). A chest x-ray is valuable in evaluation. Tunnel edema usually subsides within 24 hours. Presence of a kink or a malpositioned tip requires replacement of the catheter using a different tunnel or a different length of the catheter. It is also important to have an insertion site in the lower part of the neck close to the clavicle; a high insertion site in the neck can cause the catheter to become “positional,” with blood flow changing with the position of the neck. Eventually, the catheter tips move up with neck movement, leading to poor blood flow. An exit site close to the breast tissue can also pull the tip of the catheter high into the superior vena cava. Exposed cuff or tunnel due to traction on the line or erosion of tissue increases risk of malfunction and infection. These catheters require exchange. If the tunnel is eroded or infected, a new tunnel or new placement site is required. Left internal jugular catheters have a higher incidence of dysfunction than those inserted on the right side (Engstrom, 2013) for reasons not entirely clear but probably related to the twisty course required to reach the opening to the right atrium.

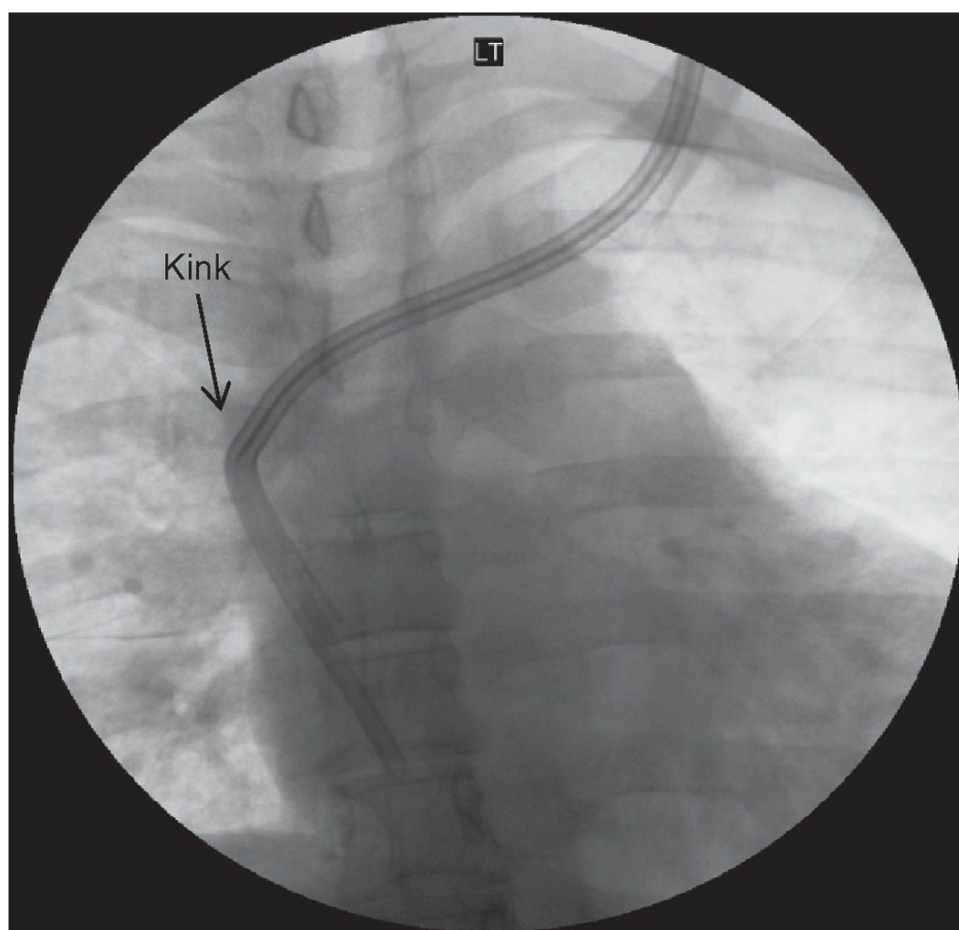

FIGURE 9.3 Kink: Left internal jugular venous catheter with a kink.

1. **Alteplase protocols.** Sometimes, early dysfunction can be due to intracatheter thrombosis. A short (1 hour) or prolonged (overnight) instillation of tissue plasminogen activator (tPA) is usually effective in treating luminal thrombosis in the short term, although long-term catheter survival is not very good. Several tPA protocols have been described (Savader, 2001; Clase, 2001) (Table 9.4). Short protocols do not necessarily perform better than dwell protocols (Vercaigne, 2012). For a detailed description of various alteplase protocols, see BC Renal Agency (2011).
- B. **Late dysfunction.** Late dysfunction is due usually to formation of a fibrin sleeve (Figure 9.4) or a mural thrombus. Almost all catheters inserted into a central vein develop a fibrin sleeve within a week or two of insertion. Such fibrin sleeves are initially clinically silent until they obstruct the ports at the distal end of the catheter. Generally, saline infuses into a port, but aspiration is difficult, producing a so-called “ball-valve” effect. Fibrin sleeves may serve as a nidus for infection. The use of warfarin or other anticoagulants on a chronic basis has not been shown to reduce fibrin sleeve or catheter thrombus formation (Mokrzycki, 2001).

TABLE

9.4

Dosing of Tissue Plasminogen Activator (tPA) for Occluded Catheters

Alteplase (1 mg/mL): Infuse 2 mg or volume of catheter into each catheter lumen as needed. For catheter lumen volumes >2 mL, after 2 mL of tPA is injected, inject sufficient normal saline to fill the catheter. For example, a 40-cm catheter with 2.6 mL volume per lumen: alteplase 2 mL injected (1 mg/mL), then 0.6 mL normal saline.

After initial administration, let the thrombolytic dwell for 30 min and then aspirate. If there is no blood return, let the thrombolytic dwell for another 30 min. If there is still no blood return, repeat the dose and aspirate again at 30 and 60 min.

If a catheter is “occluded” and the thrombolytic cannot be injected, connect a three-way stopcock to the occluded catheter hub, and with a 20-mL nonfilled syringe aspirate on the catheter. The remaining port of the three-way stopcock should have the volume of thrombolytic in a syringe. With negative pressure on the catheter, turn the stopcock so it is now open to the catheter and the thrombolytic. The negative pressure will be transferred to the thrombolytic syringe, aspirating its contents into the catheter.

Infusion Technique

When the dwell technique is unsuccessful, attempt a short-term infusion.

Begin by loading the catheter with tPA 2 mL per lumen. The concentration of tPA is 1 mg/mL. Once loaded, an infusion of tPA, 1 mg per lumen per hour, is run for 2–4 hr and then rechecked.

The amount of thrombolytic utilized with infusion is probably not of sufficient amount to cause bleeding complications, but absolute and relative contraindications should be considered, and then risk versus benefit.

Locking catheters as well as biweekly or monthly instillations of thrombolytics have reportedly reduced catheter occlusions.

For additional thrombolytic protocols, see Lok (2006) and BC Renal Agency (2011).

Adapted with permission from www.venousaccess.com.

1. **Treatment of fibrin sheath.** The presence of a fibrin sheath is usually determined at the time of catheter exchange using radiocontrast material administered through the venous port of the old catheter (Figure 9.4). The condition is usually treated with an angioplasty balloon catheter inserted on a guidewire through the catheter tunnel. The balloon catheter is passed into the lumen of the fibrin sheath and is then inflated to disrupt the fibroepithelial sheath. An 8-mm diameter balloon usually is sufficient to accomplish this task. Disruption of the sheath is then confirmed by a repeat radiocontrast injection after the new catheter has been inserted. The balloon angioplasty technique results in restoration of catheter blood flow rates sufficient for dialysis in the great majority of patients (Rasmussen, 2010; Shanaah, 2013).
- C. **Recurrent catheter dysfunction.** A substantial minority of patients with dysfunctional catheters treated by catheter replacement and balloon angioplasty will develop recurrent catheter dysfunction. Such patients will require multiple catheter replacements (Rasmussen, 2010). There is no ideal solution for such patients. Use of anticoagulants has not been shown to help, and the best resolution is conversion to an AV access where possible.



FIGURE 9.4 Fibrin sheath: left internal jugular venous catheter with fibrin sheath that extends beyond the catheter tip that has been retracted.

III. THROMBOSIS

- A. **Intraluminal thrombosis.** Catheter thrombosis is commonly treated by instillation of tPA for 1 hour or longer. Some commonly used protocols are given in Table 9.4. Mechanical brushing of thrombus has been suggested, but is unpopular. Prophylactic oral anticoagulation with warfarin does not improve catheter patency unless therapeutic levels of anticoagulation with high INR are achieved, and this can be associated with bleeding complications. Moreover, the fear of calciphylaxis and skin necrosis with warfarin therapy tends to limit its use in dialysis patients.
- B. **Central vein or intracardiac thrombosis** can occur in association with large, indwelling catheters, and these can rarely result in embolic complications. Intra-atrial thrombi need prolonged systemic anticoagulation (for 6 months or longer) and follow-up for resolution.

- C. **Emboic complications.** Large clots adherent to the end of the catheter or to the vessel wall can be clinically silent or can give rise to embolic events. Large mural thrombi can progress to stenosis and central vein thrombosis. Treatment options for a ball thrombus or a catheter-associated right atrial thrombus include simple catheter removal, systemic or catheter-assisted fibrinolytic therapy, and, rarely, thoracotomy with thrombectomy.

IV. CENTRAL VENOUS STENOSIS

- A. **Causes.** Central venous stenosis arises from endothelial injury at the sites of catheter–endothelial contact through the release of a variety of growth factors. The incidence increases with the use of stiff, nonsilicone catheters; with the use of the subclavian approach (presumably because of higher angular stresses on the catheter in the subclavian position); and in patients with previous catheter-related infections. Risk factors include a history of multiple catheter insertion (including small and large venous catheters as well as peripherally inserted central catheters, so-called PICC lines) and prolonged duration of such catheters. Collateral vessels usually develop but may not be adequate to relieve extremity edema.
- B. **Presentation and diagnosis.** Stenosis or occlusion of the subclavian vein, brachiocephalic vein, or superior vena cava usually presents with venous hypertension (swelling of the breast, shoulder, neck, and face) or vascular access dysfunction (high venous pressure on dialysis, inadequate dialysis and prolonged bleeding). A stenosis may be asymptomatic and clinically silent until unmasked by the creation of an AV fistula. Thrombosis of the AV access may result. Occlusion of multiple central veins in the chest can result in the development of superior vena cava syndrome. Careful history and examination will often reveal multiple central venous catheter scars in such patients. There may be presence of a cardiac rhythm device. Multiple collateral blood vessels are visible on examination.
- C. **Treatment.** Ligation of the vascular access produces the most rapid improvement but sacrifices the access. Initial anticoagulation (with heparin followed by warfarin) and elevation of the upper extremity on the involved side may ameliorate the symptoms and signs if thrombosis is present. More definitive therapy usually is required: Balloon angioplasty has been used for stenosis, but the lesion tends to recur. Stent placement combined with angioplasty (Figure 9.5) is indicated in elastic (easily distensible) central vein lesions or if a dilated stenosis recurs within a 3-month period. However, stent placement rarely solves the problem long term, because stenosis can reoccur around the stent. Stenosis in the subclavian vein sometimes can be relieved by an axillary vein to internal jugular vein bypass.



FIGURE 9.5 Central vein stent: left brachiocephalic vein occlusion after angioplasty and stent placement.

V. **CATHETER ADHESION.** Over the long term, indwelling catheters can develop adhesions to venous or atrial endothelium. Adherence should be suspected when an attempt to remove the catheter induces severe pain or requires significant traction. The heart or mediastinum may be pulled to one side when visualized under fluoroscopy. Removal of adhered catheters is a challenge and can require invasive techniques, including laser dissection or open surgical removal. Some novel closed maneuvers have been reported to be successful (Hong, 2011).

VI. **PORT CLAMP FRACTURE.** It is not uncommon to see a fractured port or clamp on a tunneled dialysis catheter. This can lead to suction of air or inability to double lock the port after dialysis, with an increased risk of bleeding (Amin, 2011). Often, one can replace one or both ports or clamps using replacement kits for specific catheters without having to change the entire catheter. If there has been port fracture with air suction, there is a higher risk of infection, and at the time of repair, prophylactic antibiotics should be given after drawing blood cultures.

References and Suggested Readings

Abad CL, Pulia MS, Safdar N. Does the nose know? An update on MRSA decolonization strategies.

Curr Infect Dis Rep. 2013;15:455–464.

Allon M. Dialysis catheter-related bacteremia: Treatment and prophylaxis. *Am J Kidney Dis.*

2004;44:779–791.

- Amin P, et al. Broken clamp on a cuffed tunneled catheter—are all catheters equal? *Semin Dial*. 2011;24:104–106.
- Asif A, et al. Transvenous cardiac implantable electronic devices and hemodialysis catheters: recommendations to curtail a potentially lethal combination. *Semin Dial*. 2012;25:582–586.
- BC Renal Agency. Alteplase use for occluded hemodialysis catheters. Vascular Access Guideline. Approved July 24, 2006; Updated March 4, 2011. <http://www.bcrenalagency.ca/sites/default/files/documents/files/Use-of-Alteplase-FINAL-March-4-2011.pdf>. Accessed May 26, 2014.
- Clase CM, et al. Thrombolysis for restoration of patency to haemodialysis central venous catheters: a systematic review. *J Thromb Thrombolysis*. 2001;11:127–36.
- Dotson B, et al. Physical compatibility of 4% sodium citrate with selected antimicrobial agents. *Am J Health Syst Pharm*. 2010;67:1195–1198.
- Engstrom BI, et al. Tunneled internal jugular hemodialysis catheters: impact of laterality and tip position on catheter dysfunction and infection rates. *J Vasc Interv Radiol*. 2013;24:1295–1302.
- Habib A, et al; for the Mayo Cardiovascular Infections Study Group. Impact of prior aspirin therapy on clinical manifestations of cardiovascular implantable electronic device infections. *Europace*. 2013;15:227–235.
- Hickson LJ, et al. Clinical presentation and outcomes of cardiovascular implantable electronic device infections in hemodialysis patients. *Am J Kidney Dis*. 2014;64:104–110.
- Hong JH. A breakthrough technique for the removal of a hemodialysis catheter stuck in the central vein: endoluminal balloon dilatation of the stuck catheter. *J Vasc Access*. 2011;12:381–384.
- Hwang HS, et al. Comparison of the palindrome vs. step-tip tunneled hemodialysis catheter: a prospective randomized trial. *Semin Dial*. 2012;25:587–591.
- Joshi AJ, Hart PD. Antibiotic catheter locks in the treatment of tunneled hemodialysis catheter-related blood stream infection. *Semin Dial*. 2013;26:223–226.
- Kovalik EC, et al. A clustering of epidural abscesses in chronic hemodialysis patients: risks of salvaging access catheters in cases of infection. *J Am Soc Nephrol*. 1996;7:2264–2267.
- Lok CE, et al. Trisodium citrate 4% - an alternative to heparin capping of haemodialysis catheters. *Nephrol Dial Transplant*. 2007;22:477–483.
- Mandolfo S, et al. Hemodialysis tunneled central venous catheters: five-year outcome analysis. *J Vasc Access*. 2014 Apr 25. doi:10.5301/jva.5000236.
- Maya ID, et al. Does the heparin lock concentration affect hemodialysis catheter patency? *Clin J Am Soc Nephrol*. 2010;5:1458–1462.
- Mermel LA, et al. Clinical practice guidelines for the diagnosis and management of intravascular catheter-related infection: 2009 update by the Infectious Diseases Society of America. *Clin Infect Dis*. 2009;49:1–45.
- Mokrzycki MH, et al. A randomized trial of minidose warfarin for the prevention of late malfunction in tunneled, cuffed hemodialysis catheters. *Kidney Int*. 2001;59:1935–1942.
- Poole CV, et al. Treatment of catheter-related bacteremia with an antibiotic lock protocol: effect of bacterial pathogen. *Nephrol Dial Transplant*. 2004;19:1237–1244.
- Quaretti P, et al. A refinement of Hong's technique for the removal of stuck dialysis catheters: an easy solution to a complex problem. *J Vasc Access*. 2014;15:183–188.

- Rasmussen RL. The catheter-challenged patient and the need to recognize the recurrently dysfunctional tunneled dialysis catheter. *Semin Dial*. 2010;23:648–652.
- Sabry AA, et al. The level of C-reactive protein in chronic hemodialysis patients: a comparative study between patients with noninfected catheters and arteriovenous fistula in two large Gulf hemodialysis centers. *Hemodial Int*. 2014 ;18:674–679.
- Savader SJ, et al. Treatment of hemodialysis catheter-associated fibrin sheaths by rt-PA infusion: critical analysis of 124 procedures. *J Vasc Interv Radiol*. 2001;12:711–5.
- Schiller B, et al. Spurious hyperphosphatemia in patients on hemodialysis with catheters. *Am J Kidney Dis*. 2008;52:617–620.
- Schilcher G, et al. Loss of antimicrobial effect of trisodium citrate due to ‘lock’ spillage from haemodialysis catheters. *Nephrol Dial Transplant*. 2014;29:914–919.
- Sedlacek M, et al. Aspirin treatment is associated with a significantly decreased risk of Staphylococcus aureus bacteremia in hemodialysis patients with tunneled catheters. *Am J Kidney Dis*. 2007;49:401–8.
- Shanaah A, Brier M, Dwyer A. Fibrin sheath and its relation to subsequent events after tunneled dialysis catheter exchange. *Semin Dial*. 2013;26:733–737.
- Sungur M, et al. Exit of catheter lock solutions from double lumen acute haemodialysis catheters—an in vitro study. *Nephrol Dial Transplant*. 2007;22:3533–3537.
- Tordoir J, et al. EBPG on Vascular Access. *Nephrol Dial Transplant*. 2007;22 Suppl 2:ii88–117.
- Vanholder R, et al. Catheter-related blood stream infections (CRBSI): a European view. *Nephrol Dial Transplant*. 2010;25:1753–1756.
- Vercaigne LM, et al. Alteplase for blood flow restoration in hemodialysis catheters: a multicenter, randomized, prospective study comparing “dwell” versus “push” administration. *Clin Nephrol*. 2012;78:287–296.
- Wang AY, et al. Anticoagulant therapies for the prevention of intravascular catheters malfunction in patients undergoing haemodialysis: systematic review and meta-analysis of randomized, controlled trials. *Nephrol Dial Transplant*. 2013;28:2875–2888.
- Yaseen O, et al. Comparison of alteplase (tissue plasminogen activator) high-dose vs. low-dose protocol in restoring hemodialysis catheter function: the ALTE-DOSE study. *Hemodial Int*. 2013;17:434–440.

- I. **THE HEMODIALYSIS PRESCRIPTION.** All patients are different, and the circumstances eventuating in the need for acute hemodialysis vary widely. The prescription for hemodialysis will change accordingly. As a teaching tool only, we present a “typical” prescription for an acute hemodialysis in a 70-kg adult.

Rx: Acute hemodialysis (not for initial treatment)

Session length: Perform hemodialysis for 4 hours

Blood flow rate: 350 mL/min

Dialyzer:

Dialyzer membrane: your choice

Dialyzer K_{UF} : your choice

Dialyzer efficiency: usually a dialyzer with a K_0A of 800–1200 is used

Dialysis solution composition (variable):

Base: bicarbonate 25 mM

Sodium: 145 mM

Potassium: 3.5 mM

Calcium: 1.5 mM (3.0 mEq/L)

Magnesium: 0.375 mM (0.75 mEq/L)

Dextrose: 5.5 mM (100 mg/dL)

Phosphate: none

Dialysis solution flow rate: 500 mL/min

Dialysis solution temperature: 35°C–36°C

Fluid removal orders:

Remove 2.2 L over 4 hours at a constant rate

Anticoagulation orders:

See Chapter 14

- A. **Determining dialysis session length and blood flow rate.** The dialysis session length together with the blood flow rate is the most important determinant of the amount of dialysis to be given (dialyzer efficiency is also a factor).
1. **Reduce the amount of dialysis for the initial one or two sessions.** For the initial treatment,

especially when the predialysis serum urea nitrogen (SUN) level is very high (e.g., >125 mg/dL [44 mmol/L]), the dialysis session length and blood flow rate should both be reduced. A urea reduction ratio of <40% should be targeted. This usually means using a blood flow rate of only 200 mL/min (150 mL/min in small patients) for adults along with a 2-hour treatment time and a relatively low-efficiency hemofilter. A longer initial dialysis session or use of excessively high blood flow rates in the acute setting may result in the so-called **disequilibrium syndrome**, described more fully in Chapter 12. This neurologic syndrome, which includes the appearance of obtundation, or even seizures and coma, during or after dialysis, has been associated with excessively rapid removal of blood solutes. The risk of disequilibrium syndrome is increased when the predialysis SUN level is high. After the initial dialysis session, the patient can be reevaluated and should generally be dialyzed again the following day. The length of the second dialysis session can usually be increased to 3 hours, provided that the predialysis SUN level is <100 mg/dL (36 mmol/L). Subsequent dialysis sessions can be as long as needed. The length of a single dialysis treatment rarely exceeds 6 hours unless the purpose of dialysis is treatment of drug overdose. Slow low-efficiency hemodialysis (SLED) uses low blood and dialysis solution flow rates and longer treatment sessions in order to more safely remove fluid. SLED is described in Chapter 15.

2. **Dialysis frequency and dose for subsequent treatments and dialysis adequacy.** It is difficult to deliver a large amount of dialysis in the acute setting. Most intensive care unit patients are fluid overloaded, and urea distribution volume is often much greater than 50%–60% of body weight. True delivered blood flow rate through a venous catheter rarely exceeds 350 mL/min and is often substantially lower. Recirculation occurs in venous catheters and is greatest with catheters in the femoral position owing to the low pericatheter venous flow rate. Often, the treatment is interrupted owing to hypotension. Furthermore, the degree of urea sequestration in muscle may be increased, as such patients are often on pressors, reducing blood flow to muscle and skin, which contain a substantial portion of urea and other dissolved waste products. Concomitant intravenous infusions, which are often given to patients in an acute setting, dilute the urea level in the blood and reduce further the efficiency of dialysis.

A typical 3- to 4-hour acute-dialysis session will deliver a single-pool Kt/V of only 0.9, with an equilibrated Kt/V of 0.7. Dialysate-side urea removal may be even lower (Evanson, 1999). This low level of Kt/V , if given three times per week, is associated with a high mortality in chronic, stable patients. One option is to dialyze sick patients with acute renal failure on a daily (six or seven times per week) basis. Each treatment is then approximately 3–4 hours in length. Data by Schiff (2002) suggest that mortality is reduced in patients with acute renal failure dialyzed six times per week as opposed to those receiving dialysis every other day. If every-other-day dialysis is to be given, the treatment length should probably be set at 4–6 hours, to deliver a single-pool Kt/V of at least 1.2–1.3, as recommended for chronic therapy. The VA/NIH (2008) study compared outcomes in acute patients dialyzed either 3 or 6 times per week and found absolutely no difference in outcomes. The intensity of

dialysis in the 3-times-per-week group was substantially higher (Kt/V of 1.3 or more) than in the Schiffl article. For this reason, the KDIGO workgroup on acute kidney injury (2012) recommends that when attempting to maintain acute patients on a 3-times-per-week schedule, each treatment should have a Kt/V of ≥ 1.3 . When there is a concern that there is inconsistent dialysis delivery (e.g., catheter flow or hollow-fiber thrombosis problems), one can verify HD adequacy by assessing the URR using blood tests or devices that measure real-time solute clearance (ionic conductance or UV-absorption technologies).

The amount of dialysis may need to be adjusted upward in hypercatabolic patients. A low predialysis SUN level should not be used as a justification to reduce the amount of dialysis unless substantial residual renal urea clearance is documented; many acute renal failure patients tend to have decreased urea generation rates due to lack of protein ingestion and/or to impairment of urea synthesis by the liver. Therefore, in such patients a low SUN does not necessarily reflect low levels of other uremic toxins.

B. Choosing a dialyzer

1. **Membrane material.** A Cochrane report has suggested that no firm conclusions could be drawn as of 2006 regarding the benefits of any one group of modern dialysis membranes over another for acute or chronic dialysis. The best dialyzer to select for acute dialysis, therefore, remains unclear. No recommendation favoring use of high-flux membranes for acute dialysis can be made at this time, as membrane flux has not been studied as a separate factor in any randomized study of acute dialysis.
 - a. **Anaphylactoid reactions.** These can occur and depend on both membrane material and sterilization mode. See Chapter 12 for details.
2. **Ultrafiltration coefficient (K_{UF}).** Ultrafiltration controllers are now available on all modern dialysis machines, and these accurately control the ultrafiltration rate by means of special pumps and circuits. Machines with volumetric ultrafiltration controllers are designed to use dialyzers of high water permeability (e.g., $K_{UF} > 6.0$) and may lose accuracy if a high fluid removal rate is attempted using a dialyzer that is relatively impermeable to water.

In the unlikely event that a dialysis machine with an ultrafiltration controller is not available, then a membrane with a relatively low water permeability (K_{UF}) should be chosen so that the transmembrane pressure (TMP) will have to be set at a relatively high level to remove the amount of fluid desired; then the inevitable errors in maintaining the desired TMP will have less impact on the rate of fluid removal. When close monitoring of the fluid removal rate is required and a machine with advanced ultrafiltration control circuitry is not available, the fluid removal rate can be monitored by placing the patient on an electronic bed or chair scale and continuously following the weight during dialysis.

3. **Dialyzer urea clearance.** For the first couple of dialysis sessions, it is best to avoid using very high-efficiency dialyzers, although these can be used as long as the blood flow is low. A dialyzer with an in vitro K_0A urea of about 500–600 mL/min is recommended

for the initial session to minimize the risk of inadvertent overdialysis and of developing the disequilibrium syndrome, although even with such lower efficiency dialyzers, a markedly shortened dialysis session is required to prevent overdialysis. When heparin-free dialysis is used, there is less risk (theoretically) of clotting when a lower blood flow rate is used with a smaller dialyzer, as the blood velocity through a small fiber bundle will be higher. After the initial one or two sessions, particularly if a high blood flow rate is being used, normal-sized dialyzers can be chosen.

C. **Choosing the dialysis solution.** In our example, we have chosen a bicarbonate level of 25 mM with a sodium level of 145 mM, a potassium level of 3.5 mM, a calcium level of 1.5 mM (3.0 mEq/L), a magnesium level of 0.375 mM (0.75 mEq/L), a dextrose level of 5.5 mM (100 mg/dL), and no phosphorus. Depending on the circumstances, this prescription may have to be altered in a given patient. It is important to recognize that for acute patients the dialysis solution composition should be tailored. The “standard” composition designed for acidotic, hyperphosphatemic, hyperkalemic, chronic dialysis patients is often inappropriate in an acute setting.

1. **Dialysis solution bicarbonate concentration.** In the sample prescription mentioned earlier, we have chosen to use a 25 mM bicarbonate level. Intensive care unit patients are often relatively alkalotic for reasons described in what follows, and so prescriptions for “standard” bicarbonate dialysis solution, containing 35–38 mM, should not be used without first carefully evaluating the patient’s acid–base status.

If the predialysis plasma bicarbonate level is 28 mM or higher, or if the patient has respiratory alkalosis, a custom dialysis solution containing an appropriately lower bicarbonate level (e.g., 20–28 mM, depending on the degree of alkalosis) should be used. One should remember that many dialysis solutions provide an additional 4–8 mEq/L of bicarbonate-generating base from acetate or citrate as discussed in Chapter 5. In machines where the dialysate bicarbonate level can be adjusted by changing the proportioning ratio between the acid and base concentrates, final dialysate bicarbonate levels shown on the display screen often correspond to bicarbonate after mixing with the acid concentrate, and so the value shown may not include the added base content coming from acetate or citrate.

a. **Dangers of metabolic alkalosis.** A dialysis patient with even a mild metabolic alkalosis (e.g., plasma bicarbonate level of 30 mmol/L) requires very little hyperventilation to increase blood pH to dangerous levels. Alkalemia (blood pH > 7.50) may be more dangerous than acidemia. Dangers of alkalemia include soft tissue calcification and cardiac arrhythmia (sometimes with sudden death), although documentation of the latter risk in the literature is not easy to find. Alkalemia has also been associated with such adverse symptoms as nausea, lethargy, and headache.

In dialysis patients, the most common causes of metabolic alkalosis are a reduced intake of protein, intensive dialysis for any reason (e.g., daily dialysis), and vomiting or nasogastric suction. Another common cause is administered lactate or acetate with total parenteral nutrition (TPN) solutions, or citrate due to citrate anticoagulation.

- b. **Predialysis respiratory alkalosis.** Many patients who are candidates for acute dialysis have preexisting respiratory alkalosis. The causes of respiratory alkalosis are the same as in patients with normal renal function and include pulmonary disease (pneumonia, edema, embolus), hepatic failure, and central nervous system disorders. Normally, compensation for respiratory alkalosis is twofold. There is an acute decrease in the plasma bicarbonate level owing to release of hydrogen ions from body buffer stores. In patients with normal renal function, there is a further delayed (2–3 days) compensatory fall in the plasma bicarbonate level because of excretion of bicarbonate in the urine. Renal bicarbonate excretion obviously cannot occur in dialysis patients.

The therapeutic goal should always be to normalize the pH rather than the plasma bicarbonate level. In patients with respiratory alkalosis, the plasma bicarbonate level at which the blood pH will be normal may be as low as 17–20 mmol/L; the dialysis solution to use should contain less than the usual amount of bicarbonate to achieve a postdialysis plasma bicarbonate level in the desired subnormal range.

- c. **Achieving an appropriately low dialysis solution bicarbonate level.** In certain machines, the proportioning ratio of concentrate to product water is fixed, and as a result, the dialysis solution bicarbonate level can be reduced only by changing the concentrate bicarbonate level. With such machines, the bicarbonate cannot be reduced below about 32 mM. In machines where the concentrate-to-product water ratio can be changed, bicarbonate levels as low as 20 mM usually can be delivered, but not lower, and this does not include the 4–8 mEq/L from acetate or citrate. When attempting to provide a low-base-content dialysate, sodium diacetate-containing concentrate should not be used, as this will increase the base content by 8 mEq/L.

d. **Patients with severe predialysis acidosis**

1. **Dangers of excessive correction of metabolic acidosis.** Excessive correction of severe metabolic acidosis (starting plasma bicarbonate level <10 mmol/L) can have adverse consequences, including lowering of the ionized calcium level and a paradoxical acidification of the cerebrospinal fluid and an increase in the tissue production rate of lactic acid. Initial therapy should aim for only partial correction of the plasma bicarbonate level; a target postdialysis plasma bicarbonate value of 15–20 mmol/L is generally appropriate; and for such severely acidotic patients, a dialysis solution bicarbonate level of 20–25 mM is normally used.

2. **Respiratory acidosis.** The normal compensation to respiratory acidosis is an acute buffer response, which can increase the plasma bicarbonate level by 2–4 mmol/L, followed by a delayed (3–4 days) increase in renal bicarbonate generation. Because the second response is obviated in dialysis patients, respiratory acidosis will have a more pronounced effect on blood pH than in patients with normal renal function. For such patients, dialysis solution bicarbonate levels should be at the higher range, targeted to keep their pH in

the normal range.

2. **Dialysis solution sodium level.** The dialysis solution sodium level in the sample prescription is 145 mM. This level is generally acceptable for patients who have normal or slightly reduced predialysis serum sodium concentrations. If marked predialysis hypernatremia or hyponatremia is present, the dialysis solution sodium level will have to be adjusted accordingly.

a. **Hyponatremia.** Hyponatremia is common in seriously ill patients requiring acute dialysis, primarily because such patients have often received large amounts of hyponatric intravenous solutions with their medications and parenteral nutrition. Hyponatremia is frequently seen accompanying severe hyperglycemia in diabetic dialysis patients. For every increase of 100 mg/dL (5.5 mmol/L) in the serum glucose concentration, there is a corresponding initial decrease of 1.6 mmol/L in the serum sodium concentration as a result of osmotic shift of water from the intracellular to the extracellular compartment. Because osmotic diuresis secondary to the hyperglycemia does not occur, the excess plasma water is not excreted, and hyponatremia is maintained. Correction of hyperglycemia by insulin administration reverses the initial water shift and thereby corrects the hyponatremia.

1. **Predialysis serum sodium level .130 mmol/L.** Intensive care patients often tend to be slightly hyponatremic, as they often are given various intravenous drugs in 5% dextrose and water. The goal should be to keep serum sodium at or above 140 mmol/L, and dialysis solution sodium should be in the range of 140-145 mM. The potential benefits of keeping dialysis solution sodium <10 mM above the serum level in patients with possible brain edema and/or hypotension have been reviewed by Davenport (2008).

2. **Predialysis serum sodium level ,130 mmol/L.** When the degree of predialysis hyponatremia is moderate to severe, and especially if the hyponatremia is of long duration, it is dangerous to achieve normonatremia quickly. Rapid correction of hyponatremia has been linked to a potentially fatal neurologic syndrome known as osmotic demyelination syndrome (Huang, 2007). The maximum safe rate of correction of the serum sodium concentration in severely hyponatremic patients is controversial but probably is in the range of 6-8 mmol/L per 24 hours. At this stage of incomplete knowledge, it seems prudent when treating patients with severe hyponatremia to set the dialysis solution sodium level as low as possible (with most machines one can go no lower than 130 mM, although with the Dialog Plus machine from B.Braun one can get down to a dialysate sodium of ~123 mM), and to dialyze at a slow (50-100 mL/min) blood flow rate, and for not longer than 1 hour at a time, alternating with isolated ultrafiltration as needed for volume control. One can check the serum sodium after each 30–60 min of dialysis to ensure that the desired rate of sodium increase is not being exceeded. In one case report, use of a 50 mL/min blood flow over 3 hours resulted in the desired increase in the serum sodium of 6 mmol/L over the 3-hour dialysis period (Wendland and Kaplan, 2012). Another approach is to delay dialysis for a few days if

possible and to treat hyponatremia with hypertonic saline, removing excess fluid by isolated ultrafiltration as needed. If continuous hemodialysis or hemofiltration is available, use of one of these modalities with an appropriate sodium-reduced dialysis solution/replacement fluid is another good option and allows for the greatest control of the rate of serum sodium increase (Yessayan, 2014).

b. **Hypernatremia.** Hypernatremia is less common than hyponatremia in a hemodialysis setting but does occur, usually in a context of dehydration, osmotic diuresis, and failure to give sufficient electrolyte-free water. It is somewhat dangerous to attempt to correct hypernatremia by hemodialyzing against a low-sodium dialysis solution. Whenever the dialysis solution sodium level is more than 3–5 mM lower than the plasma value, three complications of dialysis occur with increased incidence:

1. Osmotic contraction of the plasma volume occurs as water shifts from the dialyzed blood (containing less sodium than before) to the relatively hyperosmotic interstitium, causing hypotension.
2. The propensity to develop muscle cramps is increased.
3. Water from the dialyzed, relatively hyponatremic blood enters cells, causing cerebral edema and exacerbating the disequilibrium syndrome.

The risk of disequilibrium syndrome is the most important one; use of low-sodium dialysis solution should certainly be avoided in situations in which the predialysis SUN level is high (e.g., >100 mg/dL [36 mmol/L]). The safest approach is to first dialyze a patient with a dialysis solution sodium level close to that of plasma and then correct the hypernatremia by slow administration of slightly hyponatric fluids.

3. **Dialysis solution potassium level.** The usual dialysis solution potassium concentration for acute dialysis ranges from 2.0 to 4.5 mM. An important number of patients requiring acute dialysis will have a plasma potassium value in the normal or even the subnormal range, especially in patients with nonoliguric acute renal failure and in oliguric patients if food intake is poor. Hypokalemia is also a complication of TPN. Correction of severe acidosis during dialysis causes a shift of potassium into cells, lowering the plasma potassium level further. Hypokalemia and arrhythmia can result.

When the predialysis serum potassium level is <4.5 mmol/L, the dialysis solution potassium level can be ≥ 4.0 mM, with special caution needed in cardiac patients prone to arrhythmias. In patients with a predialysis plasma potassium level >5.5 mmol/L, a dialysis solution potassium level of 2.0 is usually appropriate in stable patients, but the dialysis solution potassium concentration should be raised to 2.5 to 3.5 in patients at risk for arrhythmia or in those receiving digitalis. If the potassium level is >7.0, some nephrologists will use a dialysis solution potassium level below 2.0 mM. However, the plasma potassium level must be monitored hourly, and there is considerable danger of precipitating arrhythmia if the plasma potassium concentration is lowered too rapidly.

a. **Potassium rebound.** There is a marked rebound increase in the serum potassium level

within 1–2 hours after dialysis. One should resist the temptation to treat a postdialysis hypokalemia with potassium supplements unless there are extenuating circumstances.

- b. **Acute hyperkalemia.** Patients with very severe hyperkalemia present with alterations on the electrocardiogram (low P waves, peaked T waves, widening of the QRS, cardiac standstill), along with weakness and lethargy. Such patients should be treated immediately with intravenous infusion of calcium chloride or calcium gluconate and/or intravenous glucose plus insulin while arrangements for emergency hemodialysis are being made. The response to intravenous sodium bicarbonate in dialysis patients is suboptimal. Another therapy is intravenous or inhaled albuterol.
 - c. **Subacute hyperkalemia.** Initial treatment should always be a careful review of the diet for high-potassium foods. The majority of patients respond to reduced alimentary potassium intake. If this fails, then oral administration of a sodium–potassium exchange resin (e.g., sodium polystyrene sulfonate) can be tried. The resin usually is given orally with sorbitol to prevent constipation, or mixed with sorbitol as an enema. However, several reports of intestinal necrosis associated with sorbitol and oral sodium polystyrene sulfonate have been published (e.g., Gardiner, 1997). New, potentially safer and more effective gastrointestinal potassium binders, such as ZS-9 (ZS Pharma, Inc., Coppel, TX) and Patiromer (Relypsa, Redwood City, CA) are undergoing clinical trials.
 - d. **Potassium removal and dialysis solution glucose.** Potassium removal during dialysis using glucose-free dialysis solution may be 30% greater than potassium removal using a 200 mg/dL (11 mmol/L) glucose solution because with glucose-free dialysis solution there may be decreased intradialytic translocation of potassium into cells (Ward, 1987). Use of a dialysis solution containing 100 mg/dL (5.5 mmol/L) glucose may be the best option, and this concentration is becoming the industry standard.
4. **Dialysis solution calcium levels.** Our generally recommended level for acute dialysis is 1.5–1.75 mM (3.0–3.5 mEq/L). There is some evidence that dialysis solution calcium levels <1.5 mM (3.0 mEq/L) predispose to hypotension during dialysis (van der Sande, 1998). In patients with predialysis hypocalcemia, unless a sufficiently high dialysis solution calcium level is used, correction of acidosis can result in further lowering of the ionized plasma calcium level (with possible precipitation of seizures). One study showed that QTc dispersion increased (potentially promoting arrhythmias) when a low calcium dialysis solution was used (Nappi, 2000). Routine use of 1.25 mM (2.5 mEq/L) calcium dialysis solution (now standard for treatment of chronic dialysis patients taking calcium-containing phosphorus binders) to treat patients with acute renal injury is not uncommon, however, and there is little hard evidence to show that such a practice is harmful.
- a. **Dialytic treatment of acute hypercalcemia.** Hemodialysis can be effective in lowering the serum calcium concentration in hypercalcemic patients. In most commercially prepared hemodialysis solutions, the calcium concentration ranges from 1.25 to

1.75 mM (2.5–3.5 mEq/L). Under most circumstances, we prefer to add at least 1.25 mM (2.5 mEq/L) calcium to the hemodialysis solution to minimize the possibility of an overly rapid decrease in the serum ionized calcium (which can cause tetany or seizures). Frequent measurement of the serum ionized calcium concentration and physical examination of the patient should be performed during dialysis to avoid these complications.

5. **Dialysis solution magnesium levels.** The usual dialysis solution magnesium level ranges from 0.25 to 0.75 mM (0.5–1.5 mEq/L). Magnesium is a vasodilator, and in acute dialysis, one preliminary report suggests that blood pressure is better maintained when a dialysis solution magnesium level of 0.375 mM (0.75 mEq/L) was used versus a dialysis solution containing 0.75 mM (1.5 mEq/L) magnesium (Roy and Danziger, 1996). In another article (Kyriazis, 2004), a low dialysate magnesium level of 0.25 mM (0.50 mEq/L) was associated with intradialytic hypotension, especially when a low dialysate calcium was also used. So the best dialysis solution magnesium level to use for acute dialysis in terms of blood pressure maintenance remains unknown.
 - a. **Hypomagnesemia.** Hypomagnesemia occurs in malnourished dialysis patients and in dialysis patients receiving TPN (owing to shifting of magnesium into cells during anabolism). Hypomagnesemia can cause cardiac arrhythmia and can impair the release and action of parathyroid hormone. Cautious supplementation (e.g., orally, intravenously) or increasing the concentration in the dialysate may be needed. Serum magnesium values should be carefully monitored in dialysis patients during TPN, and TPN fluids should be supplemented routinely with magnesium unless the serum magnesium level is high.
 - b. **Hypermagnesemia.** Hypermagnesemia is usually caused by accidental or covert use of magnesium-containing laxatives, enemas, or antacids. Manifestations of hypermagnesemia include hypotension, weakness, and bradyarrhythmias. Treatment is cessation of ingestion of magnesium-containing compounds. Hemodialysis also is effective in lowering the serum magnesium level.
6. **Dialysis solution dextrose level.** Dialysis solution for acute dialysis should always contain dextrose (100–200 mg/dL; 5.5–11 mmol/L). Septic patients, diabetics, and patients receiving beta-blockers are at risk of developing severe hypoglycemia during dialysis. Addition of dextrose to the dialysis solution reduces the risk of hypoglycemia and may also result in a lower incidence of dialysis-related side effects. The interaction between dialysis solution glucose and potassium has already been discussed.
7. **Dialysis solution phosphate levels.** Phosphate is normally absent from the dialysis solution, and justifiably so, as patients in renal failure typically have elevated serum phosphate values. Use of a large-surface-area dialyzer and provision of a longer dialysis session increase the amount of phosphate removed during dialysis.
 - a. **Hypophosphatemia.** Malnourished patients and patients receiving hyperalimentation may have low or low-normal predialysis serum phosphate levels. Predialysis hypophosphatemia may also be present in patients being intensively dialyzed for any purpose. In such patients, hypophosphatemia can be aggravated by dialysis against a zero-phosphate bath. Severe hypophosphatemia can cause respiratory

muscle weakness and alterations in hemoglobin oxygen affinity. This can lead to respiratory arrest during dialysis. For patients at risk, phosphate can be added to the dialysis solution. Alternatively, phosphate can be given intravenously, although this must be done carefully to avoid overcorrection and hypocalcemia. Rapid correction of hypophosphatemia with intravenous phosphate has been associated with acute kidney injury (AKI). In one study, administration of 20 mmol over an average of 310 minutes was deemed generally safe, but was associated with a fall in ionized calcium in some patients, suggesting that a slower rate of replacement might be desirable (Agarwal, 2014).

- b. **Adding phosphorus to bicarbonate-containing dialysis solutions.** For prevention of hypophosphatemia, the phosphorus concentration in the final dialysis solution should be about 1.3 mmol/L (4 mg/dL). Phosphorus cannot be added to concentrate for acetate-containing dialysis solutions because of Ca–Mg–PO₄ solubility problems. Phosphorus designed for IV use can be added to the bicarbonate component of the concentrate, which does not contain calcium or magnesium (Hussain, 2005). An alternative approach is to add sodium phosphate-containing enema preparations to either the bicarbonate or acid concentrate, as described in Chapter 16. The amount added can be set to achieve a final dialysis solution phosphorus concentration of 1.3 mM (4.0 mg/dL); however, this practice is not Food and Drug Administration-approved.

Of practical importance, adding phosphate or other supplements may be technically difficult or not feasible in facilities that rely on the dialysis machine to automatically mix the base solution from dry bicarbonate reagent.

- D. **Choosing the dialysis solution flow rates.** For acute dialysis, the usual dialysis solution flow rate is 500 mL/min.
- E. **Dialysis solution temperature.** This is usually 35°C–37°C. The lower range should be used in hypotension-prone patients (see Chapter 12).
- F. **Ultrafiltration orders.** Fluid removal needs can range from 0 to 5 kg per dialysis session.
 1. **Guidelines for ultrafiltration orders.** Some guidelines to gauge the total amount of fluid that needs to be removed are as follows:
 - a. Even patients who are quite edematous and in pulmonary edema rarely need removal of more than 4 L of fluid during the initial session. Remaining excess fluid is best removed during a second session the following day.
 - b. If the patient does not have pedal edema or anasarca, in the absence of pulmonary congestion, it is unusual to need to remove greater than 2–3 L over the dialysis session. In fact, the fluid removal requirement may be zero in patients with little or no jugular venous distention. Fluid removal rates of 10 mL/kg per hour are usually well tolerated in volume overloaded patients.
 - c. The fluid removal plan during dialysis should take into account the 0.2 L that the patient will receive at the end of dialysis in the form of saline to rinse the dialyzer and any other fluid ingested or administered during the hemodialysis session.
 - d. As already noted, if it is the initial dialysis, the length of the dialysis session should be limited to 2 hours. However, if a large amount of fluid (e.g., 4.0 L) must

be removed, it is impractical and dangerous to remove such an amount over a 2-hour period. In such instances, the dialysis solution flow can initially be shut off, and isolated ultrafiltration (see Chapter 15) can be performed for 1–2 hours, removing 2–3 kg of fluid. Immediately thereafter, dialysis can be performed for 2 hours, removing the remainder of the desired fluid volume. (If severe electrolyte abnormalities, such as hyperkalemia, are present, dialysis may have to be performed prior to isolated ultrafiltration.)

- e. In general, it is best to remove fluid at a constant rate throughout the dialysis treatment. If the dialysis solution sodium level has been set lower than the plasma value (e.g., in the treatment of hypernatremia), the ultrafiltration rate can initially be reduced to compensate for the osmotic contraction of blood volume that will occur as the plasma sodium concentration is being lowered.

In patients with acute renal failure, it is extremely important to avoid hypotension at all times, including during dialysis. In a rat model of acute renal failure, Kelleher (1987) showed that the renal autoregulatory response to systemic hypotension is greatly impaired. They found that transient episodes of hypotension caused by blood withdrawal caused further renal damage and delay of functional renal recovery.

2. **Impact of dialysis frequency on ultrafiltration needs.** It is difficult in an acute setting to limit a patient's fluid gain to <2 L per day. Often 3 L per day is absorbed in patients receiving parenteral nutrition. Use of a frequent (4–7 times per week) dialysis schedule reduces the amount of fluid that needs to be removed with each dialysis, thereby lowering the risk of intradialytic hypotension and further ischemic damage to an already impaired set of kidneys. An alternative way to remove fluid relatively asymptotically is to use SLED, a procedure described in Chapter 15.

II. HEMODIALYSIS PROCEDURE

A. **Rinsing and priming the dialyzer (single-use setting).** Thorough rinsing of the dialyzer is important because it may reduce the incidence or severity of anaphylactic dialyzer reactions by virtue of removal of leachable allergens (e.g., ethylene oxide in ethylene oxide–sterilized dialyzers).

B. **Obtaining vascular access**

1. **Percutaneous venous cannula.** Clot or residual heparin is first aspirated from each catheter lumen. Patency of the catheter lumina is checked by irrigating with a saline-filled syringe. For acute dialysis, heparin-free dialysis is becoming more popular and is routinely used in some centers. If heparin is to be used, the heparin loading dose is administered into the venous catheter port and is flushed in with saline. After 3 minutes (to allow heparin to mix with the blood), blood flow is initiated.
2. **Arteriovenous (AV) fistula** (see also Chapter 6). Both needles are placed in the vein downstream to the anastomosis. Flow through the venous limb is distal to proximal; hence, the arterial needle is placed distally. Some tips regarding needle placement are as follows:
 - a. In a patient with a poorly distended venous limb, brief application of a tourniquet

may be helpful in defining its location. This tourniquet should be removed during dialysis, as its presence will encourage recirculation.

- b. Choice of optimum needle size is discussed in Chapter 6. Larger needle sizes can be used when higher blood flow rates are desired.
 - c. Prepare the needle insertion sites with chlorhexidine or other suitable disinfectant.
 - d. **Arterial needle.** Insert it first, at least 3 cm away from the site of the AV anastomosis. The needle should be inserted bevel up, pointing either upstream or downstream.
 - e. **Venous needle.** Insert bevel up, pointing downstream (usually this will be toward the heart). The insertion point customarily is inserted at least 3–5 cm downstream to the arterial needle to minimize entry of dialyzed blood into the arterial needle (recirculation), although one study suggests that closer needle placement does not result in recirculation (see Chapter 6).
 - f. **Angle of needle insertion.** This depends on the depth of the access from the surface of the skin, and usually is 20–35 degrees for AV fistulas, and 45 degrees for AV grafts (Brouwer, 1995).
3. **AV graft.** The anatomy of the graft should be known and preferably diagrammed in the patient's chart. The guidelines for placing needles are the same as for the AV fistula. Use of a tourniquet is never necessary.

After the needles have been placed, if heparin is to be used, the heparin loading dose is given into the venous needle and flushed in with saline. After 3 minutes, flow through the blood circuit is initiated.

- C. **Initiating dialysis.** The blood flow rate is initially set at 50 mL/min, then 100 mL/min, until the entire blood circuit fills with blood. As the blood circuit fills, the priming fluid in the dialyzer and tubing can either be given to the patient or disposed of to drain. In the latter instance, the venous blood line is kept to drain until the blood column passes through the dialyzer and reaches the venous air trap. In unstable patients, the priming fluid is usually administered to the patient to help maintain the blood volume.

After the circuit is filled with blood and proper blood levels in the venous drip chamber are ensured, the blood flow rate should be increased promptly to the desired level. The pressure levels at the inflow (arterial) monitor, between the access site and the blood pump, and of the outflow (venous) monitor, between the dialyzer and the venous air trap, are noted, and the pressure limits are set slightly above and below the operating pressure to maximize the probability that the blood pump will stop and alarms will sound in the event of a line separation. If a line separation does occur, the pressure in the blood line will rapidly approach zero. As it does, it should trigger a properly set pressure limit switch. The lower pressure limit on the venous pressure gauge should be set within 10–20 mm Hg of the operating pressure; a larger gap can cause failure of the alarms to trigger with line separation. Unfortunately, even properly set venous pressure limits may not stop the pump if the venous needle dislodges or if there is a line separation. This issue is discussed in more detail in Chapter 4. For this reason, connections to the access should always be securely taped and kept visible to caregivers at all times (Van Waelegheem, 2008; Ribitsch, 2013).

The dialysis solution flow can now be initiated. In machines with an ultrafiltration controller, the desired fluid removal rate is simply dialed in.

- D. **Beeps, buzzers, and alarms.** As introduced in Chapter 4, the monitors on the dialysis solution machine include the following:

Blood Circuit

Inflow pressure

Outflow pressure

Air detector

Dialysis Solution Circuit

Conductivity

Temperature

Hemoglobin

1. **Blood circuit (see Fig. 4.1)**

- a. **Inflow (prepump) pressure monitor.** Usually, the inflow pressure (proximal to the blood pump) is -80 to -200 mm Hg, with -250 mm Hg being considered the usual limit beyond which one does not go.

If the access is not providing sufficient blood to the pump, the suction proximal to the blood pump will increase, and the alarm will sound, shutting off the blood pump.

1. **Causes of excessive inflow suction**

- a. **Venous catheter access.** Usually improper tip position or ball-valve thrombus or fibrin plug at the catheter tip.

b. **AV access**

- i. Improperly positioned arterial needle (needle not in vessel or up against vessel wall)
- ii. Decrease in the patient's blood pressure (and hence flow through the access)
- iii. Spasm of the access vessel (AV fistula only)
- iv. Stenosis of the arterial anastomosis of an AV graft or fistula
- v. Clotting of the arterial needle or of the access
- vi. Kinking of the arterial line
- vii. Collapse of the access due to elevation of the arm (if this is suspected, sit the patient up, blood pressure permitting, until the access site is below heart level)
- viii. Use of too small a needle for the blood flow rate being used

2. **Management**

- a. **Venous catheter.** Check lines for kinking. Sometimes, changing arm or neck position or moving the catheter slightly makes the catheter work. Reversing the catheter ports is another maneuver that sometimes works. If these initial steps do not work, subsequent steps include urokinase or tissue plasminogen activator infusion, checking catheter position in the radiology suite, or fibrin sleeve stripping as described in Chapter 9.

a. **AV access**

- i. Reduce blood flow rate to the point that inflow suction decreases and the alarm stays off.
Verify that the patient's blood pressure is not unusually low.

- ii. If the pressure is low, correct it by administering fluid or reducing the ultrafiltration rate.
 - iii. If a patient's pressure is not unusually low, untape the arterial needle, move it up or down slightly, or rotate it.
 - iv. Turn up blood flow rate to previous level. If inflow suction remains excessive, repeat step (iii).
If improvement is not obtained, continue dialysis for a longer time at a lower blood flow rate, or place a second arterial needle (leaving the original, flushed with heparinized saline, in place until the end of dialysis), and dialyze through the second needle.
 - v. If excessive inflow suction persists despite needle change, the inflow to the vascular access may be stenosed. Occlude the access between the arterial and venous needles by transient pressure with two fingers. If the negative pressure at the prepump monitor increases markedly when the intraneedle segment is occluded, this is a sign that some of the inflow was coming from the downstream access limb and that blood flow through the upstream limb of the access is inadequate.
 - vi.
- b. **Outflow (venous) pressure monitor.** Usually, the pressure here is +50 to +250 mm Hg, depending on needle size, blood flow rate, and hematocrit.
 - 1. **Causes of high venous pressure**
 - a. The pressure may be as high as 200 mm Hg when using an AV graft because the high arterial pressure in the graft is often transmitted to the venous line
 - b. High blood flow rate when using a relatively small (16G) venous needle
 - c. Clotting in the venous blood line filter if one is being used. Clotting of the filter may be the first sign of inadequate heparinization and of incipient clotting of the entire dialyzer
 - d. Stenosis (or spasm) at the venous limb of the vascular access
 - e. Improperly positioned venous needle or kinked venous line
 - f. Clotting of the venous needle or venous limb of the vascular access
 - 2. **Management of high venous pressure**
 - a. If clotting of the venous blood line filter is at fault, the dialyzer should be rinsed with saline (by opening up the saline infusion line and briefly clamping the blood inlet line proximal to the saline infusion port). If the dialyzer is not clotted (fibers appear clear on saline rinse), then a new venous line can be rapidly primed with saline and substituted for the partially clotted line, and dialysis can be resumed after adjusting the heparin dose.
 - b. The presence or absence of obstruction at the venous needle or in the venous limb of the access can be assessed by shutting off the blood pump, quickly clamping the venous blood line, disconnecting the venous blood

line from the venous needle, and irrigating through the venous needle with saline and noting the amount of resistance.

- c. Occlude the access between the arterial and venous needles by pressing down gently with two fingers. If stenosis downstream is causing outflow obstruction through the vascular access, the positive pressure measured at the venous monitor will increase further when the upstream access is occluded.
- c. **Air detector.** The danger of inadvertent air entry is greatest between the vascular access site and the blood pump, where the pressure is negative. Common sites of air entry include the region around the arterial needle (especially if the inflow suction is very high), via leaky tubing connections, via broken blood tubing as it passes through the roller pump, or via the saline infusion set. Air can also enter the patient if air return is improperly performed at the end of dialysis. Many air emboli occur after the air detector has been turned off because of false alarms. This practice should be avoided. Air embolism can be fatal.

The creation of microbubbles during dialysis and their potential adverse effects is discussed in Chapter 4.

- d. **Blood line kinking and hemolysis.** Severe hemolysis may occur because of kinking of the blood line between the pump and the dialyzer. This is a relatively common cause of dialysis machine/blood line malfunction causing patient injury. Blood lines configured for prepump pressure monitoring will not alarm if high pressures are encountered in the postpump segment between pump and dialyzer. Even if a blood line with a postpump pressure monitor is being used, if the kink is upstream to the origin of the pressure monitoring line, high pressure due to the kink will not be detected.
2. **Dialysis solution circuit monitors.** The dangers of dialyzing against an excessively concentrated, dilute, or hot dialysis solution have been discussed in Chapter 4.
 - a. **Conductivity.** The most common cause of increased dialysis solution conductivity is either a kink in the tubing routing purified water to the dialysis machine, or low water pressure, resulting in insufficient water delivery to the machine. The most common cause of a reduced conductivity is an empty concentrate bottle. Otherwise, the cause is usually in the proportioning pump. The dialysis solution bypass valve is activated as soon as conductivity deviates from the specified limits, diverting the abnormal dialysis solution away from the dialyzer to the drain.
 - b. **Temperature.** Abnormal temperature is usually caused by some malfunction in the heating circuit that warms the dialysate. Again, a properly functioning bypass valve protects the patient.
 - c. **Hemoglobin (blood leak).** False alarms may be due to the presence of air bubbles in the dialysis solution, to dialysate bilirubin in jaundiced patients, or to a dirty sensor. The dialysate may not appear to be discolored to the naked eye. A blood leak alarm should be confirmed by testing the effluent dialysate with a test strip of the sort used for detecting hemoglobin in the urine.

If a leak is confirmed, blood should be returned and dialysis discontinued.

- E. **Patient monitoring and complications.** The patient's blood pressure should be monitored as often as necessary, but at least every 15 minutes for an acute dialysis in an unstable patient. The manifestations and treatment of hypotension and other complications during dialysis are discussed in Chapter 12.
- F. **Termination of dialysis.** The blood in the extracorporeal circuit can be returned using either saline or air. If saline is used, the patient usually receives 100–300 mL of this fluid during the rinse-back procedure, nullifying the corresponding amount of fluid removed by ultrafiltration. However, if the patient's blood pressure is low at the end of dialysis, the saline bolus will help to raise the blood pressure quickly. When air is used, the blood pump is first shut off, and the arterial blood line is clamped close to the patient. The arterial blood line is then disconnected just distal to the clamp, opening it to air. The blood pump is restarted at a reduced rate (20–50 mL/min), and the air is allowed to displace the blood in the dialyzer. When the air reaches the venous air trap, or when air bubbles are first seen in the venous blood line, the venous line is clamped, the blood pump shut off, and the return procedure terminated. Use of air to return the blood increases the risk of air embolism, and the termination procedure should be extremely carefully supervised when air return is employed.
- G. **Postdialysis evaluation**
1. **Weight loss.** The patient should be weighed after dialysis whenever possible, and the postdialysis weight compared with the predialysis weight. It is not uncommon for the weight loss to be greater or less than that anticipated on the basis of the calculated ultrafiltration rate. Given the high accuracy of the volumetric ultrafiltration controllers in modern HD machines, unpredicted pre-to-post weight changes are usually due to the failure to take into account fluid administered to the patient during dialysis in the form of saline, medications, hyperalimentation, or oral fluid ingestion.
 2. **Postdialysis blood values.** Blood can be sampled promptly after dialysis to confirm the adequacy of urea nitrogen removal and correction of acidosis. For urea nitrogen, sodium, and calcium, the postdialysis specimen can be drawn 20–30 seconds to 2 minutes after dialysis, although a postdialysis increase in the plasma urea level of 10%–20% usually occurs within 30 minutes due to reequilibration of urea between various body compartments. The method of obtaining the postdialysis blood sample is quite important; if access recirculation is present, contamination of the inlet blood sample with dialyzed outlet blood can occur, yielding erroneously low plasma urea nitrogen values. The timing of the sampling is critically important in that it can help discern access recirculation, cardiopulmonary recirculation, and intercompartmental rebound effects. Reliable methods of obtaining the postdialysis sample are described in Chapters 3 and 11.
 - a. **Urea nitrogen.** The methods described in Chapters 3 and 11 can be used to estimate a predicted Kt/V and urea reduction ratio. If the plasma urea nitrogen value has fallen to a lesser extent, possible causes include partial clotting of the dialyzer, an error in setting of the blood flow rate, and recirculation at the vascular access site. Online machine methods of monitoring in vivo dialyzer clearance (ionic conductance) and Kt/V (ultraviolet absorbance of the spent dialysate) are

described in Chapter 11.

- b. **Potassium.** The change in the plasma potassium level as a result of dialysis is difficult to predict because of concomitant shifting of potassium into cells due to correction of acidosis or to cellular uptake of glucose. In acute patients, it is best to sample blood for potassium at least 1 hour after the end of dialysis.

References and Suggested Readings

- Agarwal B, et al. Is parenteral phosphate replacement in the intensive care unit safe? *Ther Apher Dial.* 2014;18:31–36.
- Brouwer DJ. Cannulation camp: basic needle cannulation training for dialysis staff. *Dial Transplant.* 1995;24:1-7.
- Casino FG, Marshall MR. Simple and accurate quantification of dialysis in acute renal failure patients during either urea non-steady state or treatment with irregular or continuous schedules. *Nephrol Dial Transplant.* 2004;19:1454–1466.
- Davenport A. Practical guidance for dialyzing a hemodialysis patient following acute brain injury. *Hemodial Int.* 2008;12:307–312.
- Emmett M, et al. Effect of three laxatives and a cation exchange resin on fecal sodium and potassium excretion. *Gastroenterology.* 1995;108:752–760.
- Evanson JA, et al. Measurement of the delivery of dialysis in acute renal failure. *Kidney Int.* 1999;55:1501–1508.
- Gardiner GW. Kayexalate (sodium polystyrene sulphonate) in sorbitol associated with intestinal necrosis in uremic patients. *Can J Gastroenterol.* 1997;11:573–577.
- Herrero JA, et al. Pulmonary diffusion capacity in chronic dialysis patients. *Respir Med.* 2002;96:487–492.
- Huang WY, et al. Central pontine and extrapontine myelinolysis after rapid correction of hyponatremia by hemodialysis in a uremic patient. *Ren Fail.* 2007;29:635-8.
- Hussain S, et al. Phosphorus-enriched hemodialysis during pregnancy: two case reports. *Hemodial Int.* 2005;9:147–150.
- Jörres A, et al; and the ad-hoc working group of ERBP. A European Renal Best Practice (ERBP) position statement on the Kidney Disease Improving Global Outcomes (KDIGO) Clinical Practice Guidelines on Acute Kidney Injury: part 2: renal replacement therapy. *Nephrol Dial Transplant.* 2013;28:2940–2945.
- Kanagasundaram NS, et al; for the Project for the Improvement of the Care of Acute Renal Dysfunction (PICARD) Study Group. Prescribing an equilibrated intermittent hemodialysis dose in intensive care unit acute renal failure. *Kidney Int.* 2003;64:2298–2310.
- KDIGO. KDIGO clinical practice guidelines for acute kidney injury. *Kidney Int.* 2012;2(suppl 1):1–141.
- Kelleher SP, et al. Effect of hemorrhagic reduction in blood pressure on recovery from acute renal failure. *Kidney Int.* 1987;31:725.
- Ketchersid TL, Van Stone JC. Dialysate potassium. *Semin Dial.* 1991;4:46.
- Kyriazis J, et al. Dialysate magnesium level and blood pressure. *Kidney Int.* 2004;66:1221–1231.
- MacLeod AM, et al. Cellulose, modified cellulose and synthetic membranes in the haemodialysis of patients with end-stage renal disease. *Cochrane Database Syst Rev.* 2005;(3):CD003234.

- Madias NE, Levey AS. Metabolic alkalosis due to absorption of “nonabsorbable” antacids. *Am J Med.* 1983;74:155–158.
- Nappi SE, et al. QTc dispersion increases during hemodialysis with low-calcium dialysate. *Kidney Int.* 2000;57:2117–2122.
- Palevsky PM, et al. KDOQI US commentary on the 2012 KDIGO clinical practice guideline for acute kidney injury. *Am J Kidney Dis.* 2013;61:649–672.
- Ribitsch W, et al. Prevalence of detectable venous pressure drops expected with venous needle dislodgement. *Semin Dial.* 2013 Dec 17. doi:10.1111/sdi.12169.
- Roy PS, Danziger RS. Dialysate magnesium concentration predicts the occurrence of intradialytic hypotension [Abstract]. *J Am Soc Nephrol.* 1996;7:1496.
- Schiffl H, Lang SM, Fischer R. Daily hemodialysis and the outcome of acute renal failure. *N Engl J Med.* 2002;346:305–310.
- Subramanian S, Venkataraman R, Kellum JA. Related articles, links influence of dialysis membranes on outcomes in acute renal failure: a meta-analysis. *Kidney Int.* 2002;62:1819–1823.
- Sweet SJ, et al. Hemolytic reactions mechanically induced by kinked hemodialysis lines. *Am J Kidney Dis.* 1996;27:262–266.
- van der Sande FM, et al. Effect of dialysate calcium concentrations in intradialytic blood pressure course in cardiac-compromised patients. *Am J Kidney Dis.* 1998;32:125–131.
- Van Waeleghem JP, et al. Venous needle dislodgement: how to minimise the risks. *J Ren Care.* 2008;34:163–168.
- VA/NIH Acute Renal Failure Trial Network, Palevsky PM, et al. Intensity of renal support in critically ill patients with acute kidney injury. *N Engl J Med.* 2008;359:7–20.
- Ward RA, et al. Hemodialysate composition and intradialytic metabolic, acid–base and potassium changes. *Kidney Int.* 1987;32:129.
- Wendland EM, Kaplan AA. A proposed approach to the dialysis prescription in severely hyponatremic patients with end-stage renal disease. *Semin Dial.* 2012;25:82-5.
- Yessayan L, et al. Treatment of severe hyponatremia in patients with kidney failure: Role of continuous venovenous hemofiltration with low sodium replacement fluid. *Am J Kidney Dis.* 2014;64:305-310.

Web References

Acute dialysis—recent articles and abstracts. <http://www.hdcn.com/ddacut.htm>.



Chronic Hemodialysis Prescription

John T. Daugirdas

Please review Chapter 3 at this time. Many concepts developed in Chapter 3 will be only briefly touched on here.

- I. **UREA AS A MARKER SOLUTE.** Although uremic toxicity is due to both small- and large-molecular-weight solutes, small toxins appear to be of greater importance. For this reason (and there are practical, laboratory measurement issues as well), the amount of dialysis prescribed is based on removal of urea, which has a molecular weight of 60 Da. Urea is only slightly toxic per se, and so its plasma level is only reflecting concentrations of other, presumably more harmful, uremic toxins.
 - A. **Urea removal versus serum level.** Both removal and serum level should be monitored when checking dialysis adequacy. Monitoring of urea removal is more important. If removal is inadequate, then dialysis is inadequate, regardless of the serum level. On the other hand, a low serum urea level does not necessarily reflect adequate dialysis. Serum level depends not only on the rate of removal but also on the rate of urea generation. The generation rate is linked to the protein nitrogen appearance rate because most protein nitrogen is excreted as urea. A low serum urea level may be found in patients in whom removal is poor but in whom the generation rate is also low (e.g., due to poor protein intake).
 - B. **Measures of urea removal.** These are the urea reduction ratio (*URR*), the single-pool *Kt/V* (*spKt/V*), the equilibrated *Kt/V* (*eKt/V*), and the weekly standard *Kt/V* (*stdKt/V*) (see Chapter 3).
 - C. **Dose of dialysis in terms of urea removal for thrice-weekly dialysis.** In a secondary analysis of the randomized National Cooperative Dialysis Study, the rate of treatment failure increased dramatically in patients dialyzed three times per week when *spKt/V* was <0.8 , compared with when values were >1.0 . In large observational studies, similar results were found. For this reason, the KDOQI Adequacy Workgroups have recommended a minimum *spKt/V* for dialysis patients of 1.2, with a target value of at least 1.4. This translates to a *stdKt/V* urea value of 2.1 when *stdKt/V* is calculated using modeling or by a method that takes volume contraction into account. The European Best Practice Guidelines recommend a slightly higher minimum amount of dialysis, defined as a minimum *eKt/V* of 1.2. Values for *eKt/V* values tend to be about 0.15 units lower than *spKt/V*, the amount depending on the rate of dialysis. High-level evidence guideline recommendations depend

on randomized studies, and in the field of dialysis adequacy, the only other larger randomized study that has been done is the HEMO study, where an $spKt/V$ of 1.7 was compared with an $spKt/V$ of 1.3 (the study doses were actually defined in terms of eKt/V). Patients assigned to the higher dose of dialysis did not live longer, were not hospitalized less frequently, and were not found to manifest nutritional or other benefits. Apart from these two studies, there is little high-quality evidence regarding dialysis dose and outcomes, and almost all recommendations and guidelines in this area are primarily opinion-based.

1. **Effect of gender.** In the randomized analysis of the HEMO trial, the women assigned to the higher dose of dialysis survived longer than the women assigned to the standard dose. Survival in the men assigned to the higher dialysis dose was slightly worse, so the overall effect of dose in the HEMO trial was negative, and it is not clear whether this dose–gender interaction was real or just a statistical fluke. If women need more dialysis, the reason is unclear. As detailed in Chapter 3, an alternative method of scaling dialysis dose might be to scale to body surface area (BSA) instead of by urea distribution volume (V). In healthy patients and in children, glomerular filtration rate (GFR) naturally scales to BSA, and an adult man and woman with similar values for BSA will have similar levels of GFR (Daugirdas, 2009). Because the ratio of V :BSA is about 12%–15% different in men than in women, under current dosing guidelines, if a man and a woman have the same level of V , they will get the same dose of dialysis; however, BSA in the woman will be 12%–15% higher, so theoretically one might argue that women need about 15% more dialysis than men. If one wishes to increase the dose of dialysis in terms of $stdKt/V$, the increase in $spKt/V$ has to be increased by about twice as much. So this line of reasoning would suggest that the minimum $spKt/V$ in women should be about 25%–30% higher than that in men. However, the optimum method of scaling dialysis dose is not known, and there are no firm data other than the HEMO study and a few observational studies to suggest that BSA should be used to scale dialysis dose instead of V .
2. **Smaller patients.** One can come up with four reasons why smaller patients should get relatively more dialysis when dose is measured as $spKt/V$:
 - a. Small patients (those with small values for V) would get a larger amount of dialysis if dose were scaled to BSA.
 - b. The KDOQI dose targets are in the form of $spKt/V$ and not eKt/V ; postdialysis urea rebound tends to be larger in smaller patients.
 - c. It is fairly easy to deliver a high Kt/V to small patients (and also women) in a short session length (e.g., 2.5 hours). Such short session lengths may not be sufficient to allow for removal of middle molecules, nor for adequate removal of excess fluid, and this may result in a chronically overhydrated patient.
 - d. Short session length treatments may give a seemingly adequate Kt/V level, but in patients who gain large amounts of fluid between treatments, short session lengths may require a relatively high ultrafiltration (UF) rate to remove this fluid and high UF rates are associated with a poor outcome.
3. **Malnourished patients.** When a patient's weight is substantially below the weight of

his or her peers, or when a patient has lost a large amount of weight, one opinion is to scale dialysis to the patient's optimum "healthy" weight, and not the current reduced weight. The thinking is that the increased amount of dialysis will help return the patient to his or her healthier, premorbid condition.

4. **Residual renal urea clearance (K_{ru}).** Whether patients with substantial residual kidney function can be managed with lower doses of dialysis is an unanswered question. In one large study, when patient urine volume was >100 mL per day, the amount of dialysis delivered had little impact on survival (Temorshuizen, 2004). Methods of adjusting dialysis dose for residual kidney function are entirely opinion-based. There are a variety of modeling-based adjustments that can be used. Readers can look to the European Best Practice recommendations (2002) and to the NKF-KDOQI 2006 adequacy guidelines for some suggested guidance.

D. **Adequacy targets for schedules other than three times per week.** There is no high-level evidence that can guide us in terms of dose titration when dialysis is given other than three times per week. One approach is to maintain a minimum $stdKt/V$ (calculated using modeling or the FHN equation) of 2.1 across all dialysis schedules (Table 11.1). The value of 2.1 was chosen because it corresponds to a three-times-per-week schedule with an $spKt/V$ of 1.2 (NKF-KDOQI, 2006).

1. **Four to six sessions per week.** In one randomized trial that showed a benefit of more frequent dialysis, the FHN Daily Trial, the average delivered $stdKt/V$ averaged 3.7, considerably higher than the 2.1 minimum dose suggested by NKF-KDOQI. The average number of treatments delivered per week was 5, and the average delivered session length was 154 minutes (FHN Trial Group, 2010).
2. **Twice-a-week dialysis.** In the developing world, many patients are dialyzed only twice a week for economic reasons, and in the United States, this was not unusual in the recent past. Kinetic modeling using an $stdKt/V$ approach suggests that twice-a-week dialysis is not appropriate in patients without some modest degree of residual kidney function. On the other hand, there are preliminary data suggesting that starting incident patients out on twice-a-week dialysis may result in longer preservation of residual kidney function (Kalantar Zadeh, 2014). One observational study of twice-a-week dialysis done in the United States was unable to show an adverse association for this treatment strategy, and outcomes were actually a bit better than in patients dialyzed three times per week. Lack of harm may have been due to preferential selection of patients with some residual kidney function (Hanson, 1999), but there was no definitive evidence that this was the case.

TABLE

11.1

Minimum^a $spKt/V$ Values for Various Frequency Schedules of Dialysis (Achieving an Estimated $stdKt/V = 2.1$)

Schedule ^b	$K_{r} .2 \text{ mL/min per } 1.73 \text{ m}^2$	$K_{r} .2 \text{ mL/min per } 1.73 \text{ m}^2$
Two times per week	Not recommended	2.0

Three times per week	1.2	0.9
Four times per week	0.8	0.6

Assumes session lengths of 3.5–4 hr; K_r = residual kidney clearance.

^a Target $spKt/V$ values should be about 15% higher than the minimum values shown.

^b Frequent dialysis (five and six times per week) is more completely discussed in Chapter 16.

Adapted from NKF-KDOQI Clinical Practice Recommendations. Hemodialysis Adequacy. Update 2006. *Am J Kidney Dis.* 2006;48:(Suppl1):S2–S90.

E. Adequacy targets based on metrics other than urea removal.

1. **Dialysis time.** Urea removal is only one measure of dialysis adequacy. For solutes such as phosphorus and middle molecules, total weekly time is the major determinant of removal. Short weekly time also makes it difficult to remove excess salt and water from patients safely and effectively. The US KDOQI 2006 adequacy work group recommended a minimum session length of 3 hours for patients dialyzed three times per week with little residual renal function. The European Best Practices Group (2002) recommends a minimum 4-hour treatment time. The benefits of dialysis sessions longer than 3.5 hours are not clear, and seem to be greatest in Japan and intermediate in Europe; benefits are difficult to demonstrate in the United States (Tentori, 2012), perhaps because of the more intense dialysis given in that country. Also, dose-versus-outcomes data may be confounded by dose-targeting bias, a situation where survival is higher in patients who are meeting whatever dose target is being applied (Daugirdas, 2013). In the United States, the average dialysis time is about 3.5 hours and is increasing toward 4 hours, similar to the practice in the rest of the world. A large randomized study (TiMe trial) is currently underway in the United States to determine whether setting a minimum dialysis time of 4.25 hours for all new (incident) patients, regardless of body size, will result in meaningful outcome benefits. A substantial number of patients in the United States dialyze in-center overnight for about 6–9 hours per treatment. This strategy is described more completely in Chapter 16.

Another argument against Kt/V is that a focus on urea removal tends to drive high-efficiency dialysis, with use of large dialyzers and rapid blood flows; the high efficiency of such treatments may result in solute disequilibrium and intradialytic side effects. Also, high blood flow rates delivered using the requisite larger needle sizes may engender more blood turbulence and platelet activation, as well as access dysfunction. A related question is whether one should make “optimum” use of the dialysis time by prescribing the highest blood flow that is consistently achievable, and using the most efficient (high K_0A) dialyzer that one can afford. An alternative “slow and gentle” approach remains popular in Europe, according to which low blood flow rates and relatively small dialyzers are used. There are no randomized trials available to help choose between these two options. The best approach may be to set targets on the basis of both Kt/V (perhaps with higher minimum targets for women and smaller patients) and dialysis time. Changing the Kt/V target to a surface-area-adjusted value by itself solves the problem of short dialysis time given to smaller patients and women,

as the amount of dialysis given to such patients based on surface area needs to be considerably larger, and this takes more time to deliver.

II. WRITING THE INITIAL PRESCRIPTION

A. **The dialysis dose: $K \times t$.** A dialysis prescription involves two main components: K , the dialyzer clearance, and t , the dialysis session length. K , in turn, depends on the dialyzer size used and the blood flow rate. The dialysate flow rate also plays a small role as discussed in Chapter 3.

1. **K usually ranges from 200 to 260 mL/min.** For adult patients dialyzed using a blood flow rate of 400 mL/min, dialyzer clearance K will usually be about 230 ± 30 mL/min. One can use a urea kinetics calculator or a nomogram such as Figure 13.6, to get a reasonable estimate of dialyzer clearance from the blood flow rate and the efficiency of the dialyzer (K_0A) being used. If we assume that K will be 250 mL/min for a dialysis session length of 4 hours, $K \times t$ will be $250 \times 240 = 60,000$ mL or 60 L. This represents the total volume of blood cleared of urea during the dialysis session.
2. **Targeting $K \times t$ on the basis of patient size and desired Kt/V .** Assume that we have a clearance of 250 mL/min and a session length of 4 hours. How large a patient could we dialyze and still meet KDOQI guidelines? Remember that the guidelines suggest using a prescribed $(K \times t)/V$ of 1.4 to ensure that the delivered dose stays above 1.2. Over the 4-hour session we are delivering 60 L of $K \times t$, and if we want a prescribed Kt/V of 1.4, V must be $60/1.4 = 43$ L, corresponding to a weight of about 78 kg. See Tables 11.2 and 11.3 for some additional examples.

TABLE

11.2

The Initial Prescription for a Specific Patient to Achieve a Desired $spKt/V$.

Step 1: Estimate the patient's V .

Step 2: Multiply V by the desired Kt/V to get the required $K \times t$.

Step 3: Compute required K for a given t , or the required t for a given K .

Step 1. Estimate V . This is best done from anthropometric equations incorporating height, weight, age, and gender as devised by Watson (Appendix A). If the patient is African American, add 2 kg to the Watson value for V_{ant} . Alternatively, one can use the Hume–Weyers equations or the nomogram derived from them (Appendix A). Assume that, in this case, the estimated V is 40 L.

Step 2. Compute the required $K \times t$. If the desired Kt/V is 1.5 and the estimated V is 40 L, then the required $K \times t$ is 1.5 times V , or $1.5 \times 40 = 60$ L.

Step 3. Compute the required t or K . The required $K \times t$ can be achieved with a variety of different combinations of K (which depends on K_0A , Q_B , and Q_D) and t . A variety of urea modeling programs are available that will do a computer simulation of various scenarios and come up with many possible combinations of K and t . Internet-based calculators can be accessed via the Web References cited at the end of this chapter.

Given a desired session length t , how to compute required K .

One approach is to input a session length t and then ask: What kind of dialyzer, blood flow rate, and dialysate flow rate would I then need to achieve the required $K \times t$? Again, simple algebra is sufficient. From the previous example:

Desired $\text{sp}Kt/V = 1.5$; $V_{\text{ant}} = 40 \text{ L}$, $K \times t = 60 \text{ L}$

First, convert $K \times t$ to milliliters to get 60,000 mL. If the desired session length is 4 hr, or 240 min:

Desired $t = 240 \text{ min}$

Required $K = (K \times t)/t = 60,000/240 = 250 \text{ mL/min}$

Now that we know the required K , how to choose K_0A , Q_B , and Q_D .

How does one now choose K_0A , Q_B , and Q_D ? A simple way is to select the most rapid value of Q_B that can be reliably and consistently delivered. Assume in this patient that a blood pump speed of 400 mL/min will be possible. One can then go to the K - K_0A - Q_B nomogram (Figure 13.6) to find the approximate dialyzer K_0A value that will be required to achieve a K of 250 mL/min at a blood flow rate of 400 mL/min.

To find the required dialyzer K_0A , find 400 (which is Q_B) on the horizontal axis, then go up until you find 250 (desired K) on the vertical axis. At this point, you are on a K_0A line of about 900, so a dialyzer with a K_0A value of at least 900 mL/min will be needed. If such a high-efficiency dialyzer is not available, one will need to dialyze longer than 4 hours. Some 5%–10% improvement in K can be obtained by increasing dialysate flow rate to 800 mL/min. However, with some modern dialyzers that include spacer yarns to optimize dialysate flow around the fibers, increasing dialysate flow from 600 to 800 mL/min was shown to have very little impact (Ward, 2011).

TABLE

11.3

Given an Actual Blood Flow Rate (Q_B), How to Compute Required Session Length Given Two Possible Choices of Dialyzers

A common situation occurs when the maximum blood flow rate that can be reliably delivered is known. Often, one has a choice between using a larger (more expensive) or a smaller (slightly cheaper) dialyzer. Let us assume that one is constrained to use a dialysate flow rate of 500 mL/min. What would the dialysis session length then need to be to achieve a target $\text{sp}Kt/V$ of 1.5? Let us assume that we are prescribing for the same patient, with an estimated V of 40 L, which means that $K \times t$ again must be 60 L, or 60,000 mL. Assume that the projected blood flow rate is 400 mL/min. Of the two dialyzers available, we look up their K_0A (maximum clearance) values and find they are 1,400 mL/min for the larger one and 800 mL/min for the smaller one. So how long do we need to dialyze this patient with each of the two dialyzers?

Step 1: From Figure 13.6 (which we can use because $Q_D = 500 \text{ mL/min}$), find the K corresponding to

Q_B of 400 mL/min (x -axis value) for each of the two dialyzers. K will be the value on the vertical axis that corresponds to the intersection of the 1,400- and 800- K_0A lines with a perpendicular rising from the horizontal axis (Q_B) at a point representing 400 mL/min. We find that the K values are about 270 mL/min for the bigger ($K_0A = 1,400$) dialyzer and 220 mL/min for the smaller ($K_0A = 800$) dialyzer.

Step 2: We know that $spKt/V = 1.5$ and estimated $V = 40$ L. Our desired $K \times t$ is 60 L, or 60,000 mL. By algebra:

$$\begin{aligned} 800-K_0A \text{ dialyzer, } K = 200: t &= \frac{(K \times t)}{K} = \frac{60,000}{220} = 273 \text{ min} \\ 1400-K_0A \text{ dialyzer, } K = 270: t &= \frac{(K \times t)}{K} = \frac{60,000}{270} = 222 \text{ min} \end{aligned}$$

Our calculations thus suggest that we will need to dialyze for 50 minutes longer using the smaller ($K_0A = 800$) dialyzer to achieve the same $spKt/V$ of 1.5.

B. How weight change during dialysis affects the dialysis prescription. In patients who have large weight gains, one will need a higher Kt/V to get a given URR than in patients with minimal weight gain (see Figure 3.14 in Chapter 3). For example, to get a URR of 70%, one needs to prescribe a Kt/V of only 1.3 if no fluid is removed, but one needs a Kt/V of 1.5 if the weight loss during dialysis (UF/W) is 6% of the body weight (see the 0.06 UF/W line in Figure 3.14).

III. CHECKING THE DELIVERED DOSE OF DIALYSIS. The dialysis dose is usually monitored on a monthly basis, according to KDOQI guidelines, by drawing a predialysis and postdialysis serum urea nitrogen (SUN). Alternatively and/or additionally, in vivo dialyzer clearance can be monitored during each treatment by checking the dialyzer sodium clearance, or delivered dialysis dose can be followed by tracking the UV absorbance of the spent dialysate, as described in Chapter 3.

The pre- and post-SUN values are used to compute the URR , which is then combined with information concerning UF/W and with some other adjustments to compute the delivered $spKt/V$. One caveat: When checking the URR , one must be sure to use a properly drawn postdialysis blood specimen. In the presence of access recirculation, the postdialysis blood may be low due to admixture with dialyzer outlet blood unless a slow-blood-flow or a stop-dialysate-flow technique is used. Two KDOQI-suggested techniques for blood drawing are described in Table 11.4, and the reasons behind them are explained in detail in Chapter 3.

A. Methods of computing $spKt/V$ from the pre- and post-SUN

1. **Nomogram method.** One uses Figure 3.14 as described before. Assume that a URR of 0.70 or 70% is measured. Depending on whether 0%, 3%, or 6% of the body weight was removed during the dialysis treatment, the delivered $spKt/V$ for that treatment will be 1.3, 1.4, or 1.5, respectively.
2. **More exact methods.** The optimal method recommended by the KDOQI guidelines to calculate Kt/V is to use a urea kinetic modeling program. The basic principles of how

such programs work are described in Chapter 3. These programs are available commercially, and one, Solute Solver, is available on the Internet (<http://www.ureakinetics.org>). An alternative method that is approved by KDOQI is to use the following equation (Daugirdas, 1993):

$$spKt/V = -\ln(R - 0.008 \times t) + (4 - 3.5 \times R) \times UF/W$$

where R is $(1 - URR)$, or simply post-SUN/pre-SUN, t is the session length in hours, $-\ln$ is the negative natural logarithm, UF is the weight loss in kilograms, and W is the postdialysis weight. See Chapter 3 for a more complete discussion of this formula.

TABLE

11.4

Guidelines for Obtaining the Postdialysis Serum Urea Nitrogen Sample

Principles

The effect of access recirculation will reverse quickly. When blood flow is slowed to 100 mL/min, the inflow urea concentration will rise in about 10–20 s (depending on the amount of dead space in the arterial line, usually about 10 mL).

Method

1. Set UF rate to 0.
2. Slow the blood pump to 100 mL/min for 10–20 s.
3. Stop the pump.
4. Draw a sample, either from the arterial blood line sampling port or from the tubing attached to the arterial needle.

Alternate Method

1. Set UF rate to 0.
2. Put dialysate into bypass.
3. Keep blood flow going at usual rate; wait 3 min.
4. Draw the sample.

IV. **ADJUSTING THE INITIAL DIALYSIS PRESCRIPTION.** When patients are put on a particular dialysis prescription, even when there are no apparent changes in therapy, the delivered $spKt/V$ derived from the measured URR often will vary considerably from month to month. The reasons are not completely clear, but laboratory error in measuring the SUN values in the samples, possible variations in how the postdialysis blood is drawn and variations in actual session length, time-averaged blood flow rate, and dialyzer clearance may all have a role. It may be useful to average the $spKt/V$ value from three monthly treatments to determine whether or not the standard minimum $spKt/V$ of 1.2 is being delivered.

Example: Assume that we want to target an $spKt/V$ of 1.5. The patient is monitored monthly, and from the URR the following $spKt/V$ values are obtained:

Month	spKt/V
Jan	1.40
Feb	1.35
Mar	1.54
Apr	1.30

The average of these values is 1.40. Although this is well within KDOQI targets for dialysis adequacy, if one wishes to achieve the original $spKt/V$ goal of 1.5, one needs to increase the numerator ($K \times t$) in Kt/V by a factor of $1.5/1.4$, or 1.07 (7%).

One now has a choice in that either the K or the t term can be increased by 7% (or each one can be increased so that their product increases by 7%). The simplest way to increase Kt/V from 1.4 to 1.5 is to increase dialysis session length by 7%. This would mean adding 17 minutes to a 4-hour treatment ($1.07 \times 240 = 257$ minutes). Another option is to try to increase the K term by going to a higher blood flow rate, going to a larger dialyzer, or increasing the dialysate flow rate. However, it is often difficult to increase the blood flow rate further. The impact of changing to a more efficient dialyzer can be estimated from the K_0A versus clearance nomogram shown in Figure 3.6. Increasing dialysate flow rate to 800 mL/min, which typically results in about a 5%–10% increase in clearance as long as the blood flow rate is >400 mL/min might also do the trick, but is not always helpful with some advanced dialyzers where the dialysate flow path is already optimized (Ward, 2011).

V. **THE CONCEPT OF MODELED V .** One of the advantages of using a modeling program is that the computer calculates how much urea was removed, and then, on the basis of the URR , weight change and session length, calculates the size of the volume from which the urea appears to have been removed. To do this, the computer uses a “marbles in the box” approach described in Chapter 3. It is important to recognize that V is a tool that is used to assess dialysis adequacy. It does not always reflect the true urea distribution volume. Computers are not very smart, in the sense that they use only the information given to them. For example, if the URR and hence $spKt/V$ suddenly decrease owing to a batch of bad dialyzers, all the computer knows is that the $spKt/V$ has suddenly fallen, but it is not told that the dialyzer clearance (K) has changed. Also, the session length (t) has not changed. How, then, can the computer explain the sudden decrease in $spKt/V$ if $K \times t$ is unchanged? All it knows is that $(K \times t)/V$ is lower than it was, and that $(K \times t)$ is unchanged. The only way the computer can explain this scenario is to assume that the patient’s urea distribution volume (V) must have increased. A marked change in a patient’s true volume happens only rarely, so a rise in modeled V usually means that for some reason, less dialysis was given than was ordered or anticipated.

A. **Monitoring modeled V in individual patients.**

Example 1. In a different patient, in May an $spKt/V$ of 1.5 is delivered, and the computer models the size of the patient’s urea volume (modeled V) as 43 L. Values for the subsequent 4 months are as shown.

Month	$spKt/V$	Modeled V
May	1.5	43
Jun	1.43	45
Jul	1.7	38
Aug	1.8	36
Sep	1.1	58

A transient increase in the value for V was found in September owing to an unexpectedly low value for the $spKt/V$. What should be done at this point?

Step 1: Review the dialysis run sheet for the September treatment. The low $spKt/V$ and the apparent rise in V most probably reflect an unrecorded decrease in K or t . Was the treatment shortened? Was the blood flow rate reduced during all or part of the treatment? Did the dialysate concentrate run out? Were there problems with access during the treatment? If the answer to these questions is no, it can be assumed that the aberrant result was most likely due to measurement error.

Step 2: The prescription should not be changed at this point. One approach is to obtain one or more additional pre-/post-SUN measurements to determine whether the low $spKt/V$ value was a fluke or something about which to be concerned. The September $spKt/V$ measure is still 1.1, which is close to the minimum KDOQI guideline of 1.2, so, one could justify waiting for the next regular monthly blood draw. This situation shows why having some sort of machine-generated clearance, from either dialyzer sodium clearance or UV dialysate absorbance, would be of great help, as these clearances are measured every treatment, and they would show whether the low September value is an anomaly or some form of laboratory error.

A repeat $spKt/V$ should be measured, and if the repeat value is still low, this means that some major problem has developed in delivering either the prescribed K or t . The most likely explanation that would cause a decrease in $spKt/V$ of this magnitude would be the development of access recirculation. Other potential causes are discussed in Table 11.5.

Example 2 (sustained fall in V). Suppose that in another patient we have a sustained increase in $spKt/V$ for no apparent reason, causing a decrease in modeled V :

	Month	$spKt/V$	Modeled V
	Jul	1.2	54
	Aug	1.15	56
	Sep	1.35	48
	Oct	1.18	55
	Nov	1.5	43
	Dec	1.43	45
	Jan	1.5	43
	Feb	1.43	45
	Mar	1.7	38
	Apr	1.47	43

Here we have a patient whose V was initially about 54 L, and then, sometime around November, the V appeared to decrease suddenly to about 44 L. The treatment was unchanged. $spKt/V$ jumped from 1.2 to 1.5, so the computer interprets this as a patient who has shrunk. What could cause this (Table 11.5)?

- Step 1: The first possibility to rule out is a true decrease in V , which can occur either because of better removal of chronic overhydration or because of loss of lean body mass due to intercurrent illness. Such a massive change is unlikely and can easily be ruled out by checking the patient's weights.
- Step 2: Review the dialysis run sheets. Assuming that the patient's weight has not markedly decreased, true V has not decreased. Rather, the $K \times t$ must have increased in some manner relative to that delivered in October. The goal is to explain how this could have occurred. One needs to compare the run sheets before and after October. It is possible that a preexisting problem in delivering the entire session length or prescribed blood flow rate that was active prior to October was corrected in October and the months that followed.
- Step 3: Access recirculation/needle placement. If there was a change in access in October, then this might have resulted in cessation of access recirculation, or perhaps prior to October the needles were being reversed and after October the problem was found and corrected.
- Step 4: Check to see whether there was a systematic change in how the blood samples were collected. Consider the following scenario: This patient always had access recirculation; however, prior to October, the postdialysis sample was drawn using a proper slow-flow method. Then, in October a new technician arrived, who drew the postdialysis samples after simply stopping the blood pump, without any antecedent slow-flow period to clear the blood line of recirculated blood. This would result in a sudden, unexplained drop in the postdialysis SUN, which would translate into a factitious rise in the URR and $spKt/V$, with a concomitant fall in modeled V .

TABLE

11.5

Reasons Why the Urea Reduction Ratio-Based Delivered $spKt/V$ May Be Different Than Prescribed Kt/V

Reasons why delivered Kt/V may be less than prescribed (in this case, modeled V will be increased)

Patient's V greater than initial estimate (initial R_x only)

Actual blood flow less than that marked on the blood pump (very common when prepump negative pressure is high)

Blood flow temporarily lowered (symptoms or other reasons)

Actual dialysis session length shorter than prescribed

Dialyzer K_0A less than expected (manufacturer specifications incorrect, decreased due to reuse, etc.)

Access recirculation or inadvertent needle reversal (when postdialysis SUN is drawn properly using a slow-flow period prior to the draw)

Rebound (use of delayed postdialysis SUN to compute $spKt/V$ and V)

Reasons why delivered Kt/V may be greater than prescribed (in this case, modeled V will be

decreased)

Patient's V less than initial estimate (initial R_x only) or recent, severe weight loss

Postdialysis SUN specimen artifactually low

Access recirculation or inadvertent needle reversal, and postdialysis blood contaminated with dialyzer outlet blood (slow-flow method not used)

Specimen drawn from dialyzer outlet blood line

Session length longer than the time recorded

Recent correction of access recirculation or inadvertent needle reversal

SUN, serum urea nitrogen.

VI. MONITORING CHANGES IN V FOR THE ENTIRE UNIT AS A QUALITY ASSURANCE TOOL . Whereas large fluctuations in V can occur in individual patients, averaging the modeled V for the entire unit is useful as a quality assurance tool and can identify several problems associated with dialysis delivery. Here, a small change in V for the unit over time can often be detected. It is useful to compute both an anthropometric V (V_{ant}) and the modeled V for each patient, and to follow the ratio of the two. Unit wide, V/V_{ant} should average close to 0.90–1.0. An average unit-wide ratio >1.0 suggests that one or both components of $K \times t$ are being overestimated.

VII. INABILITY TO REACH THE DESIRED $spKt/V$. Patients in whom it is difficult to reach an $spKt/V$ of at least 1.2 fall into three categories: (a) patients with poor access, resulting in either limitation of blood flow and/or access recirculation; (b) very large patients; and (c) patients with frequent hypotension, angina, or other side effects, resulting in frequent reductions in blood flow during dialysis.

A. Therapy four times per week. Four-sessions-per-week schedules are becoming increasingly popular for treating larger patients as well as patients with hypertension and problems with removing excess fluid. The 2006 version of the KDOQI clinical practice recommendations suggest that with such schedules, when residual renal urea clearance is below 2.0 mL/min per 1.73 m², the minimum $spKt/V$ value can be reduced from 1.2 to about 0.8 (Table 11.1). One additional advantage of a four-per-week schedule is that it avoids the long, weekend interdialytic interval, around which adverse events and deaths are more common (Foley, 2011).

VIII. COMPUTING AND MONITORING THE NORMALIZED PROTEIN NITROGEN APPEARANCE RATE (nPNA). This is described in Chapter 3, and monitoring of nutritional status is discussed in Chapter 31.

IX. CHOICE OF DIALYZER

A. Membrane material. Issues pertaining to biocompatibility and acute dialyzer reactions are discussed in Chapters 4, 10, and 12.

B. Should a high-flux dialyzer be used? This question was partially answered by the NIH HEMO

trial. Although randomization to high-flux membranes was associated with about an 8% increased survival, this did not attain statistical significance. Significant benefits in survival were measured in the predefined subgroup of patients who were on dialysis longer than 3.7 years (the median level for the HEMO patients). Also, cardiovascular mortality appeared to be reduced in all patients assigned to high-flux dialysis. These data are generally in accord with the European MPO trial (Locatelli, 2009). On the basis of these results, both the KDOQI Adequacy Workgroup in 2006 (reiterated in 2015) and the European Best Practices Group recommend the use of a high-flux membrane where proper water treatment is available. Use of high-flux membranes may also reduce the incidence of beta-2 microglobulin amyloidosis in patients dialyzed for many years. It is not clear whether this benefit is due to enhanced removal of beta-2 microglobulin or whether use of more advanced dialysis technology associated with high-flux dialysis results in less procedure-related inflammation.

X. FLUID REMOVAL ORDERS

A. **Concept of “dry weight” or optimum postdialysis weight.** The so-called “dry weight” (optimum postdialysis weight is a better term) is the postdialysis weight at which all or most excess body fluid has been removed. If the dry weight is set too high, the patient will remain in a fluid-overloaded state at the end of the dialysis session. Fluid ingestion during the interdialysis interval might then result in edema or pulmonary congestion. If the dry weight is set too low, the patient may suffer frequent hypotensive episodes during the latter part of the dialysis session. Patients who have been ultrafiltered to below their optimum postdialysis weight often experience malaise, a washed-out feeling, cramps, and dizziness after dialysis. The postdialysis recovery is extremely stressful and unpleasant.

In practice, the optimum postdialysis weight of each patient must be determined on a trial-and-error basis. When setting the UF rate, allow for the 0.2 L of saline that the patient will receive at the end of dialysis during the blood return procedure. Also, compensate for any fluid ingestion or parenteral fluid administration during the treatment session.

1. **Frequent resetting of the optimum postdialysis weight.** A common error in dialysis units is failure to reevaluate the optimum postdialysis weight often enough. If a patient loses flesh weight, the previously set dry weight becomes too high, and if maintained, can result in patient overhydration and hospitalization for fluid overload. The optimum postdialysis weight should therefore be reevaluated at least every 2 weeks. A progressive decrease in the optimum postdialysis weight can be a clue to an underlying nutritional disturbance or disease process.

As discussed in Chapter 33, clinical determination of optimum postdialysis weight based on signs of edema or lung râles is unreliable. Bioimpedance devices identify an important subset of patients who appear to be markedly fluid-overloaded despite no outward signs of edema. A different subset of patients is made up of those who have been taken below their optimum postdialysis weight (Hecking, 2013). This can result in large interdialytic weight gains and heightened sodium intake as patients struggle to return to a more optimum weight, and can also result in accelerated loss of residual kidney function.

The use of bioimpedance to help identify optimum postdialysis weight, along with other technology such as lung ultrasound (“comets”), is discussed more completely in Chapter 33. While the new technology is helpful, experience with these devices is just beginning, and with whole-body bioimpedance, for example, it is not clear to what extent their estimate of fluid overload is applicable to dialysis patients of various body mass index levels.

- B. **Fluid removal rate.** Usually, fluid is removed at a constant rate during dialysis. There has been interest in restricting maximum UF rate as a quality assurance tool. Evidence suggests that patients in whom the UF rate is <12 mL/kg per hr have a higher survival rate (Movilli, 2007). It is not clear whether UF limits should be scaled to body weight, to BSA, or remain unscaled (e.g., <800 mL/hr) (Lacson, 2014). There are several approaches by which the fluid removal rate can be reduced. The most obvious is to extend the dialysis time, but this is not the only approach: reducing interdialytic weight gain by limiting sodium intake often is more acceptable to the patient and easy to implement (Burkart, 2012). In patients with substantial urine volume, use of diuretics will reduce UF rate by virtue of increasing daily urine volume unless the patient reacts by taking in more fluid.

There is some interest in using a nonconstant fluid removal rate during a dialysis session. In one approach, the fluid removal rate is increased during the initial 1–2 hours of dialysis and reduced toward the end of dialysis. The dialysis solution sodium level also may be increased during the initial phase of dialysis to help maintain the blood volume osmotically. The benefits of this approach remain controversial.

XI. DIALYSIS SOLUTIONS (Table 11.6)

- A. **Flow rate.** The standard dialysis solution flow rate is 500 mL/min. When the blood flow rate is high (e.g., >400 mL/min) and when a high- K_0A dialyzer is used, increasing the dialysis solution flow rate to 800 mL/min will increase dialyzer clearance (K) by about 5%–10%. The optimum value for the dialysis solution flow rate is 1.5 to 2.0 times the blood flow rate.

B. **Composition**

1. **Bicarbonate concentration.** Bicarbonate dialysis solution is the fluid of choice, and use of acetate-based dialysate is now considered obsolete in most countries.

The concentration of base should be adjusted to achieve a predialysis plasma bicarbonate concentration of 20–23 mmol/L. There has been some interest in increasing dialysis solution bicarbonate level, or giving supplementary oral bicarbonate to increase the predialysis HCO_3 level. A definite clinical benefit of raising predialysis HCO_3 beyond 20–23 has not been shown. Metabolic alkalosis may result postdialysis in such patients, with theoretical increased risk of calcium–phosphorus precipitation, and of cardiac arrhythmia.

Flow rate:

500 mL/min

Base:

Bicarbonate (32 mM)/plus acetate (4 mM); or bicarbonate 28 mM / plus acetate 8 mM^a

Electrolytes and dextrose:

Potassium = 2.0 mM (3.0 mM for patients taking digitalis, or patients with a low-normal potassium predialysis)

Sodium = 135–145 mM (138 mM)

Dextrose = 100 mg/dL (5.5 mmol/L)

Calcium = 1.25–1.5 mM (2.5–3.0 mEq/L; depends on the type of phosphate binder used)

Magnesium = 0.50 mM (1.0 mEq/L)

^aFor example, when using sodium diacetate (Granuflo) dry acid concentrate.

As discussed in Chapter 4, in dialysis machines that are capable of adjusting the dialysis solution bicarbonate level, the machine readout usually gives the bicarbonate level of the product dialysate not taking into account the presence of any bicarbonate-generating anions such as acetate or citrate. Acetate, especially when sodium diacetate is used in the concentrate, can add as much as 8 mM of bicarbonate-generating base to the dialysate. This added base content should be kept in mind when titrating dialysis solution to bicarbonate to the serum level.

The average dialysis solution bicarbonate level tends to be higher in the United States than in some European countries, and high dialysis bicarbonate values have been associated with increased mortality (Tentori, 2013). The increased mortality was due primarily to infectious, rather than to cardiovascular, causes. It is not at all clear whether this association is causal or mediated by some sort of confounding. Mortality is increased in patients with both low and high predialysis serum bicarbonate, but the mortality at the high end is confounded by malnutrition, as patients with low predialysis serum bicarbonate levels are commonly malnourished.

High dialysis solution bicarbonate has been shown to act synergistically with low dialysis solution calcium and potassium (Di Iorio, 2012) to prolong the QTc interval on the electrocardiogram, a change associated with increased risk of arrhythmia.

- Potassium.** The usual dialysis solution potassium level is 2.0 mM unless the patient's usual predialysis plasma potassium concentration is <4.5 or unless the patient is receiving digitalis. In the latter two instances, the dialysis solution potassium level should usually be 3.0 mM. Should the interdialytic serum potassium levels be high because of the use of this 3-mM dialysis solution, chronic administration of sodium polystyrene sulfonate resin may be required. The new potassium-binding compounds under development, ZS-9 (ZS Pharma, Coppell, TX) and Partimer (Relypsa, Redwood City, CA) respectively, may increase caregiver options in this regard.

Malnourished patients may have low predialysis serum potassium levels, and in

these patients the dialysate potassium level can and should be increased to avoid hypokalemia. Use of 1.0-mM potassium dialysate on a chronic basis to control hyperkalemia has been associated with increased incidence of cardiac arrest (Lafrance, 2006). If a low dialysis solution potassium level is used at all, it should be used on a relatively short-term basis. If the patient stops ingesting a high-potassium diet for whatever reason, continued use of a low-potassium dialysis solution can then result in adverse consequences. Survival is highest in patients being dialyzed against a 3 K bath or higher (Jadoul, 2012).

3. **Sodium.** The usual dialysis solution sodium level is between 135 and 145 mM. Levels above 138 mM are associated with increased thirst and weight gain between dialyses, although the extra fluid often can be removed during dialysis with fewer symptoms. The blood pressure may increase. Dialysis solution sodium levels lower than 135 mM predispose to hypotension and cramps.

One study suggests that patients may have individual “set points” for sodium (Keen, 1997). Little is known about why some dialysis patients have low predialysis sodium values. Predialysis hyponatremia has been linked to overhydration and increased interdialytic weight gain. In nondialysis populations, as well as in dialysis patients, hyponatremia is associated with an increased mortality risk. These patients may have cardiac dysfunction with nonosmotic release of vasopressin, or some sort of “sick cell” syndrome with impairment of the Na–K exchanger, reflecting overall poor health. In patients with a low sodium set point, a lower dialysis sodium level can logically be used, which should minimize postdialysis thirst and weight gain. However, a cross-sectional study found slightly better survival when hyponatremic patients were dialyzed against higher sodium dialysis solution (Hecking, 2012).

4. **Dextrose.** In the United States, it is common to add dextrose (200 mg/dL or 11 mmol/L) to dialysis solutions. The presence of dextrose may reduce the incidence of hypoglycemia during dialysis. In Europe, a lower dextrose concentration, 100 mg/dL or 5.5 mmol/L, is commonly used. The Europeans may be right, as some data suggest that the lower glucose level still protects against hypoglycemia, but is associated with better control of blood sugar. Also, high dialysis glucose solutions encourage potassium (and possible phosphorus) entry into cells, reducing their removal during dialysis.
5. **Calcium.** Dialysis solution calcium levels in chronic patients normally range from 1.25 to 1.5 mM (2.5–3.0 mEq/L). The usual level in patients taking calcium-containing phosphorus binders is 1.25 mM (2.5 mEq/L), but the level may have to be adjusted upward or downward depending on clinical response and parathyroid hormone status. In patients taking the newer resin-based phosphate binders, which do not contain calcium, the dialysis solution calcium level may need to be increased to avoid negative calcium balance. Dialysis solution calcium levels lower than 1.25 mM (2.5 mEq/L) have been advocated by some when calcium-containing phosphorus binders are used, in order to prevent calcium overload. However, use of such low dialysate calcium solutions has been associated with increased risk of sudden cardiac arrest (Pun, 2013).
6. **Magnesium.** The usual dialysis solution magnesium level is 0.25–0.5 mM (0.5–1.0

mEq/L). In general, dialysis patient survival is better when such patients are not hypomagnesemic. Also, frequent use of protein-pump inhibitors in this population may reduce oral magnesium absorption and increase the risk of hypomagnesemia (Alhosaini, 2014). The trend is to use 0.5 mM (1.0 mEq/L) solution, at the higher end of this range.

- C. **Temperature.** The dialysate temperature should be set as low as possible without engendering patient discomfort, generally in the range of 34.5°C–36.5°C. As discussed in Chapter 12, individualization of cool dialysate, effected by measuring patient tympanic membrane temperature and setting dialysis solution temperature 0.5°C lower, may retain the benefits of cool dialysis solution in terms of protection from intradialytic hypotension and shortening of postdialysis recovery time, while avoiding the discomfort of feeling cold and shivering. Individualized cool dialysate also may reduce the incidence of myocardial stunning and dialysis-associated ischemic damage to brain white matter. In one study from China, use of cool temperature dialysis solution chronically was associated with reduced cardiovascular morbidity and mortality (Hsu, 2012).

XII. **ANTICOAGULATION ORDERS.** See Chapter 14.

XIII. **STANDING ORDERS FOR COMPLICATIONS.** Complications are discussed in depth in Chapter 12. Frequently occurring complications, such as hypotension, cramps, restlessness, nausea, vomiting, itching, and chest pain, can be managed with a set of standing orders. However, symptoms during dialysis may be the result of a more serious disease process that can require immediate diagnosis and specific treatment.

XIV. **PATIENT MONITORING**

A. **Prior to and during the treatment session**

1. **Prior to dialysis**

- a. **Weight.** The predialysis weight should be compared with the patient's last postdialysis weight and with the target optimum weight to obtain some idea of interdialysis weight gain. A large interdialysis weight gain, especially when coupled with symptoms of orthopnea or dyspnea, should prompt a complete cardiovascular examination and reassessment of the target weight (it may be too high). Patients should strive to keep their interdialysis weight gain below 1.0 kg per day, although the average weight gain tends to be higher. They also need to be counseled about limiting sodium rather than fluid intake, as the water intake generally follows that of salt. Excessive thirst may be due to a high dialysis solution sodium level. Complaints of a washed-out feeling or of persistent muscle cramps after dialysis suggest that the target postdialysis weight is too low. As noted above, postdialysis recovery time can be shortened by use of cool dialysis solution.
- b. **Blood pressure.** The optimum blood pressure to monitor is controversial, and either average intradialytic pressure or postdialysis pressure may be more predictive of volume overload than predialysis pressure (see Chapter 33). In some

patients, blood pressure can increase during dialysis despite fluid removal. The causes are speculative, but this has been associated with poor survival. Volume-resistant hypertensive patients sometimes benefit from further fluid removal, and blood pressure may decrease only after a lag period of several months (Fishbane, 1996).

Patients with hypertension are routinely counseled to withhold their blood pressure medication on the day of dialysis to limit the incidence of dialysis hypotension. This is not absolutely necessary, especially for patients who will be dialyzed in the afternoon. Management of high blood pressure is described in Chapter 33, but basically focuses on sodium restriction, lengthening the weekly dialysis time, and, if available, moving to a more frequent dialysis schedule. Use of whole-body bioimpedance to guide fluid removal has been shown to lower blood pressure. Abiding by a maximum UF rate and using this as an incentive to get patients to reduce interdialytic weight gain can also reduce blood pressure (Burkart, 2012).

While it is important to investigate and perhaps treat patients with very high levels of predialysis blood pressure, very aggressive approaches to reduce predialysis blood pressure have been associated with an increased rate of dialysis hypotension and access failure (see Chapter 33).

c. **Temperature.** The patient's temperature should be measured. The presence of a fever prior to dialysis is a serious finding and should be investigated diligently. The manifestations of infection in a dialysis patient may be subtle. On the other hand, a rise in body temperature of about 0.5°C during dialysis is normal and not necessarily a sign of infection or pyrogen reaction.

d. **Access site.** Whether or not fever is present, the vascular access site should always be examined for signs of infection before each dialysis.

2. **During the dialysis session.** Blood pressure and pulse rate are usually measured every 30–60 minutes. Any complaints of dizziness or of a washed-out feeling are suggestive of hypotension and should prompt immediate measurement of the blood pressure. Symptoms of hypotension may be quite subtle, and patients sometimes remain asymptomatic until the blood pressure has fallen to dangerously low levels.

B. Laboratory tests (predialysis values)

1. **Serum urea nitrogen.** This should be measured monthly as part of the *URR*. Whether the monthly postdialysis BUN measurement can be dispensed with in units where in vivo dialyzer clearance is monitored using conductivity, or patient *Kt/V* is monitored via UV dialysate absorbance, is an open question. Use of the predialysis urea nitrogen would continue to be useful, as it allows for computation of the nPNA.

2. **Serum albumin.** The predialysis serum albumin level should be measured every 3 months. The serum albumin concentration is an important indicator of nutritional state. A low serum albumin level is a very strong predictor of subsequent illness or death in dialysis patients. The increased mortality risk begins at serum albumin levels <4.0 g/dL (40 g/L). Patients with serum albumin levels <3.0 g/dL (30 g/L) are at high risk of morbid events, and every effort should be made to find the cause of the low albumin value and correct it.

3. **Serum creatinine.** The predialysis serum creatinine level is measured monthly. The usual mean value in hemodialysis patients is about 10 mg/dL (884 $\mu\text{mol/L}$), with a common range of 5–15 mg/dL (440–1,330 $\mu\text{mol/L}$). Paradoxically, in dialysis patients, high serum creatinine levels are associated with a low risk of mortality, probably because the serum creatinine value is an indicator of muscle mass and nutritional status.

The serum creatinine and urea nitrogen levels should be examined in tandem. If parallel changes in both occur, then alteration in the dialysis prescription or degree of residual renal function should be suspected. If the serum creatinine level remains constant but a marked change occurs in the serum urea nitrogen value, the change in the latter is most likely due to altered dietary protein intake or altered catabolic rate of endogenous body proteins.

4. **Serum total cholesterol.** The serum total cholesterol level is an indicator of nutritional status. A predialysis value of 200–250 mg/dL (5.2–6.5 mmol/L) is associated with the lowest mortality risk in dialysis patients. Low serum total cholesterol values, especially <150 mg/dL (3.9 mmol/L), are associated with an elevated mortality risk in dialysis patients, probably because they reflect poor nutritional status.
5. **Serum potassium.** Dialysis patients with a predialysis serum potassium level of 5.0–5.5 mmol/L have the lowest mortality risk. The mortality risk increases greatly for values over 6.5 and under 4.0 mmol/L.
6. **Serum phosphorus.** Measure monthly. The predialysis value associated with the lowest mortality is below 5.5 mg/dL (1.8 mmol/L). Mortality rates increase sharply for values over 9.0 mg/dL (2.9 mmol/L) and under 3.0 mg/dL (1.0 mmol/L). Current KDIGO targets are to “lower serum phosphorus toward the normal range”. Serum phosphorus values tend to be slightly higher on Monday/Tuesday, that is, after the 3-day interdialytic interval.
7. **Serum calcium.** Measure monthly (more often when changing the dose of vitamin D). The lowest mortality is associated with values of 9–12 mg/dL (2.25–3.0 mmol/L). Mortality rates increase markedly at values over 12 mg/dL (3.0 mmol/L) and under 7 mg/dL (1.75 mmol/L). The target value should be a calcium within the normal range. Targeting the upper range of normal serum calcium is no longer recommended, for fear of precipitating vascular calcification.
8. **Serum magnesium.** This is not routinely monitored in hemodialysis patients. However, hypomagnesemia is common in hemodialysis patients receiving proton pump inhibitors (Alhosaini, 2014), and low serum magnesium is associated with atrial fibrillation and poor cardiovascular outcome in many populations. The cost-benefits of routine periodic monitoring of serum magnesium have not been studied.
9. **Serum alkaline phosphatase.** Measure every 3 months. High values are a sign of hyperparathyroidism or liver disease. High levels are associated with elevated mortality risk.
10. **Serum bicarbonate.** Measure monthly. Lowest mortality is for values between 20 and 22.5 mmol/L. Mortality increases for both lower and higher values. Marked increases

in mortality are noted when the predialysis value is under 15 mmol/L. Predialysis acidosis can be corrected by administration of alkali between dialyses.

11. **Hemoglobin.** This is checked at least monthly, and in many cases every 2 weeks. Machine measurement of hemoglobin using optical sensors is becoming popular. Optimal management of chronic kidney disease related anemia is discussed in Chapter 34. Spontaneously high hemoglobin levels (without erythropoietin therapy) may be a sign of polycystic kidney disease, acquired renal cystic disease, hydronephrosis, or renal carcinoma. Serum ferritin levels, iron levels, and iron-binding capacity, as well as erythrocyte indexes, should be checked every 3 months.
12. **Serum aminotransferase values are usually checked monthly.** High or even high-normal values may unmask silent liver disease, especially hepatitis or hemosiderosis. The blood should be screened for the presence of hepatitis B surface antigen and for hepatitis C (see Chapter 35).
13. **Serum parathyroid hormone levels** should be checked every 3-6 months, as detailed in Chapter 36.

References and Suggested Readings

- Alhosaini M, et al. Hypomagnesemia in hemodialysis patients: role of proton pump inhibitors. *Am J Nephrol.* 2014;39:204–209.
- Cheung AK, et al. Effects of high-flux hemodialysis on clinical outcomes: results of the HEMO study. *J Am Soc Nephrol.* 2003;14:3251–3263.
- Daugirdas JT. Dialysis time, survival, and dose-targeting bias. *Kidney Int.* 2013;83:9–13.
- Daugirdas JT. Dialysis dosing for chronic hemodialysis: beyond Kt/V . *Semin Dial.* 2014;27:98–107.
- Daugirdas JT, et al. Relationship between apparent (single-pool) and true (double-pool) urea distribution volume. *Kidney Int.* 1999;56:1928–1933.
- Daugirdas JT. Second generation logarithmic estimates of single-pool variable volume Kt/V : an analysis of error. *J Am Soc Nephrol.* 1993;4:1205–1213.
- Depner T, et al. Dialysis dose and the effect of gender and body size on outcome in the HEMO Study. *Kidney Int.* 2004;65:1386–1394.
- Di Iorio B, et al. Dialysate bath and QTc interval in patients on chronic maintenance hemodialysis: pilot study of single dialysis effects. *J Nephrol.* 2012;25:653–660.
- Eknoyan G, et al. Effect of dialysis dose and membrane flux in maintenance hemodialysis. *N Engl J Med.* 2002;347:2010–2019.
- European Best Practice Guidelines Expert Group. Haemodialysis. *Nephrol Dial Transplant.* 2002;17(suppl 7):S16–S31.
- FHN Trial Group. In-center hemodialysis six times per week versus three times per week. *N Engl J Med.* 2010;363:2287–2300.
- Fishbane S, et al. Role volume overload in dialysis-refractory hypertension. *Am J Kidney Dis.* 1996;28:257–261.
- Foley RN, et al. Long interdialytic interval and mortality among patients receiving hemodialysis. *N Engl J Med.* 2011;365:1099–1107.
- Hanson JA, et al. Prescription of twice-weekly hemodialysis in the USA. *Am J Nephrol.*

1999;19:625–633.

- Hecking M, et al. Predialysis serum sodium level, dialysate sodium, and mortality in maintenance hemodialysis patients: the Dialysis Outcomes and Practice Patterns Study (DOPPS). *Am J Kidney Dis*. 2012;59:238–248.
- Hecking M, et al. Significance of interdialytic weight gain vs. chronic volume overload: consensus opinion. *Am J Nephrol*. 2013;38:78–90.
- Hsu HJ, et al. Association between cold dialysis and cardiovascular survival in hemodialysis patients. *Nephrol Dial Transplant*. 2012;27:2457–2464.
- Jadoul M, et al. Modifiable practices associated with sudden death among hemodialysis patients in the Dialysis Outcomes and Practice Patterns Study. *Clin J Am Soc Nephrol*. 2012;7:765–774.
- Kalantar-Zadeh K, et al. Twice-weekly and incremental hemodialysis treatment for initiation of kidney replacement therapy. *Am J Kidney Dis*. 2014;64:181–186.
- Karnik JA, et al. Cardiac arrest and sudden death in dialysis units. *Kidney Int*. 2001;60:350–357.
- Keen M, Janson S, Gotch F. Plasma sodium (CpNa) “set point”: relationship to interdialytic weight gain (IWG) and mean arterial pressure (MAP) in hemodialysis patients (HDP) [Abstract]. *J Am Soc Nephrol*. 1997;8:241A.
- Lacson, Jr, et al. Body size and gender dependent differences in mortality risks associated with ultrafiltration rates [Abstract]. *J Am Soc Nephrol*. 2013;25.
- Lafrance J, et al. Predictors and outcome of cardiopulmonary resuscitation (CPR) calls in a large haemodialysis unit over a seven-year period. *Nephrol Dial Transplant*. 2006;21:1006–1012.
- Locatelli F, et al. Membrane Permeability Outcome (MPO) Study Group. Effect of membrane permeability on survival of hemodialysis patients. *J Am Soc Nephrol*. 2009;20:645–654.
- Movilli E, et al. Association between high ultrafiltration rates and mortality in uraemic patients on regular haemodialysis: a 5-year prospective observational multicentre study. *Nephrol Dial Transplant*. 2007;22:3547–3552.
- NKF-KDOQI clinical practice guidelines; update 2006. *Am J Kidney Dis*. 2006;48(suppl 1):S2–S90.
- Pirkle JL, et al. Effect of limiting maximum ultrafiltration rate in an in-center hemodialysis population [Abstract]. *J Am Soc Nephrol*. 2012;23:6A.
- Pun PH, et al. Dialysate calcium concentration and the risk of sudden cardiac arrest in hemodialysis patients. *Clin J Am Soc Nephrol*. 2013;8:797–803.
- Saran R, et al. Longer treatment time and slower ultrafiltration in hemodialysis: associations with reduced mortality in the DOPPS. *Kidney Int*. 2006;69:1222–1228.
- Tentori F, et al. Association of dialysate bicarbonate concentration with mortality in the Dialysis Outcomes and Practice Patterns Study (DOPPS). *Am J Kidney Dis*. 2013;62:738–746.
- Tentori F, et al. Longer dialysis session length is associated with better intermediate outcomes and survival among patients on in-center three times per week hemodialysis: results from the Dialysis Outcomes and Practice Patterns Study (DOPPS). *Nephrol Dial Transplant*. 2012;27:4180–4188.
- Termorshuizen F, et al for the NECOSAD Study Group. Relative contribution of residual renal function and different measures of adequacy to survival in hemodialysis patients: an analysis of the Netherlands Cooperative Study on the Adequacy of Dialysis (NECOSAD)-2. *J Am Soc Nephrol*. 2004;15:1061–1070.
- Twardowski ZJ. Safety of high venous and arterial line pressures during hemodialysis. *Semin Dial*. 2000;13:336–337.

Ward RA, et al. Dialysate flow rate and delivered Kt/Vurea for dialyzers with enhanced dialysate flow distribution. *Clin J Am Soc Nephrol*. 2011;6:2235–2239.

Web References

HDCN adequacy channel: <http://www.hdcn.com/ch/adeq/>.

NKF KDOQI guidelines for hemodialysis adequacy: <http://www.kidney.org>.

Urea kinetics calculators: <http://www.ureakinetics.org>.

The most common complications during hemodialysis are, in descending order of frequency, hypotension, cramps, nausea and vomiting, headache, chest pain, back pain, and itching.

I. **INTRADIALYTIC HYPOTENSION.** Intradialytic hypotension (IDH) is important not only because it can cause distressing symptoms, but because it is associated with poor long-term outcomes. Patients with IDH show increased mortality (Flythe, 2014) and also an increased rate of cardiac wall motion abnormalities during dialysis, the so-called myocardial stunning (McIntyre and Odudu, 2014). There are various definitions for IDH, including a nadir (lowest) systolic BP less than 90 mm Hg, a fall in systolic BP of 20 or 30 mm Hg, or a fall in some percentage of the starting blood pressure. For quality assurance purposes, a definition of nadir systolic BP less than 90 mm Hg might be most useful as this has the strongest association with increased mortality (Flythe, 2014). The incidence of IDH is highest in patients with low predialysis blood pressure. A low predialysis blood pressure may be a marker of cardiac disease, and hearts with functional or structural abnormalities may be less able to compensate hemodynamically for fluid removal. IDH is also associated with an increased risk of access thrombosis (Chang, 2011). Mechanistic causes of IDH are detailed in Table 12.1.

A. **IDH related to blood volume changes.** Volume-related causes of IDH are most important in that the blood pressure during hemodialysis normally does not decrease (beyond an initial, trivial amount) if fluid is not removed. Thus, any maneuver that slows the ultrafiltration rate, whether it be extending the weekly time on dialysis, reducing the weekly volume of fluid ingestion, or increasing the volume of urine excreted, should reduce the rate of IDH.

1. **Avoid large interdialytic weight gains.** Emphasizing salt restriction is far more effective in decreasing interdialytic weight gain (IDWG) than focusing on fluid restriction (Tomson, 2001). Observational data find an association between a higher sodium intake and poor outcome (McCausland, 2012).

- a. Large weight gain (high ultrafiltration rate)
- b. Short weekly dialysis time (high ultrafiltration rate)
- c. Excessively low target (“dry”) weight

2. Inadequate vasoconstriction

- a. High dialysis solution temperature
- b. Autonomic neuropathy
- c. Antihypertensive medications
- d. Eating during treatment
- e. Anemia

3. Cardiac factors

- a. Diastolic dysfunction

4. Uncommon causes

- a. Pericardial tamponade
 - b. Myocardial infarction
 - c. Occult hemorrhage
 - d. Septicemia
 - e. Dialyzer reaction
 - f. Hemolysis
 - g. Air embolism
-

2. **Increasing weekly treatment time.** Increasing weekly treatment time will, by definition, decrease the required ultrafiltration rate (same weight loss, longer time), and this will decrease the frequency of IDH. The weekend long interdialytic interval is associated with a higher IDWG; if the same postdialysis weight is targeted after the weekend, a higher ultrafiltration rate will, by definition, need to be used to achieve it. In-center dialysis patients with fluid removal problems are often treated on a Mon-Wed-Fri-Sat schedule. This cuts out the long-weekend interdialytic interval and also increases the weekly dialysis time.

The KDOQI 2006 adequacy guidelines recommend that treatment time not be reduced below 3 hours (for thrice-weekly dialysis) in patients with little or no residual urine output, regardless of how high their Kt/V may be. The European Best Practice Guidelines recommend that 4 hours of therapy should be provided for all patients dialyzed on a three-per-week schedule, regardless of body size. Increasing dialysis frequency without increasing weekly dialysis time does not always reduce IDH, although in one study the degree of myocardial stunning was reduced with short daily hemodialysis (Jeffries, 2011).

3. **Maintaining and increasing urinary volume.** In patients with residual kidney function, the amount of urine volume directly subtracts from the amount of fluid that needs to be removed during dialysis. Urine volume can be increased using diuretic therapy (Lemes, 2011).

4. **Choose target weight carefully.** A patient’s target weight or “dry weight” is usually

chosen primarily on a clinical basis taking into account a patient's blood pressure, presence of edema, and tolerance of ultrafiltration to the chosen weight. The decision can be aided with the results of testing that is slowly making its way into the clinic (e.g., bioimpedance devices, measurement of serum atrial natriuretic factor levels, relative blood volume monitors, and pulmonary ultrasound). The term "target weight" may be more appropriate than "dry weight," because some level of volume overload is required in many patients to prevent IDH. This is because as the patient's dry weight is approached, the rate at which the blood compartment refills from surrounding tissue spaces is diminished. Patients who require high ultrafiltration rates may be unable to reach their true dry weight because the progressively slower refill rate as dialysis proceeds provokes transient hypovolemia at the end of treatment, often accompanied by IDH cramps, dizziness, and postdialysis malaise. More ominously, hypoperfusion of the heart, brain, and gut may have cumulative adverse consequences.

Intradialytic hematocrit monitors may help recognize a dry weight that is too high. A "flat-line" hematocrit response (e.g., lack of an increase during dialysis) despite fluid removal indicates rapid blood compartment refilling and suggests fluid overload. However, a randomized trial in which these data were utilized clinically resulted (paradoxically) in an increased, rather than a decreased, hospitalization rate (Reddan, 2005). Identification of a specific level of hemoconcentration ("crash-crit") does not appear to be useful in avoiding IDH.

The use of multifrequency bioimpedance devices to adjust target postdialysis weight is growing in popularity. Reduction of fluid overload results in a lower prevalence of left ventricular hypertrophy, a finding that is strongly associated with poor outcome. Trying to aggressively reduce blood pressure without technological guidance has been associated with increased IDH (Davenport, 2008), and with an increased rate of access failure and cardiovascular hospitalization (Curatola, 2011). Use of a multifrequency impedance monitor was associated with reduced blood pressure and left ventricular mass (Hur, 2013) without apparent side effects, although the rate of loss of urine volume was accelerated in the group using bioimpedance to lower target weight.

5. **Use an appropriate dialysis solution sodium level.** When the dialysis solution sodium level is less than that of plasma, the blood returning from the dialyzer is hypotonic with respect to the fluid in the surrounding tissue spaces. To maintain osmotic equilibrium, water leaves the blood compartment, causing an acute reduction in the blood volume. Higher dialysis solution sodium levels limit the reduction in blood volume accompanying ultrafiltration, but they also increase IDWG, blood pressure, and postdialysis thirst.

So-called sodium modeling (or sodium gradient dialysis) is widely practiced. It generally involves use of a high dialysis solution sodium early in treatment (145–155 mM) with a progressive fall (linear, step, or logarithmic) to lower levels (135–140 mM) at the end of treatment. The objective is to obtain the benefits of high-sodium dialysis solution without its complications. Review of the large literature on this subject shows that sodium modeling is of uncertain benefit (Stiller, 2001). It should

also be noted that a patient's postdialysis serum sodium is a function of a treatment's time-averaged concentration of dialysis solution sodium, not the terminal level of dialysis solution sodium.

Instead of a "one size fits all" level of dialysis solution sodium, using a fixed level set close to the patient's predialysis serum value—an "individualized" dialysis solution sodium—may reduce symptoms as well as interdialytic thirst (Santos, 2010). Recent data indicate that using a relatively high dialysis solution sodium (>142 mmol/L) may benefit frail patients at high risk for IDH, likely because the consequences of recurrent IDH are more dire than those from using a high-sodium dialysis solution (Marshall and Dunlop, 2012). On the other hand, use of a relatively low dialysate sodium level can reduce IDH because it tends to lower IDWG and the need for ultrafiltration (Shah and Davenport, 2012).

6. **Blood volume control devices with feedback loop.** For a number of years now, software has been allowing improved feedback control of ultrafiltration rate based on monitoring of blood volume during dialysis. Some randomized trials suggest that such feedback devices can reduce the incidence of dialysis-induced hypotension while avoiding a positive sodium balance (Davenport, 2011).

B. **Hypotension related to lack of vasoconstriction.** In the hypovolemic state, cardiac output is limited by cardiac filling; a reduction in either peripheral vascular resistance or cardiac filling in this setting can precipitate hypotension. Under conditions of decreased cardiac filling, increases in heart rate have little effect on cardiac output. Because more than 80% of the total blood volume circulates in veins, changes in venous capacity can have important effects on a patient's effective circulating blood volume and cardiac output. When arteriolar resistance decreases, more arterial pressure is transmitted to veins, causing passive stretching and distension, and an increased sequestration of blood. While not important in euvolemic patients given a vasodilator (because cardiac filling is more than adequate), this mechanism can result in hypotension when hypovolemia is present (Daugirdas, 1991). The degree of arteriolar constriction, or total peripheral resistance (TPR), is also important because TPR will determine the blood pressure for any level of cardiac output.

1. **Lower dialysis solution temperature.** Ideally, the dialysis solution temperature should be one that maintains a patient's arterial blood temperature at its initial level throughout dialysis. When the dialysis solution temperature is higher than this ideal level, cutaneous vasodilation occurs to allow heat to be dissipated. This vasodilation reduces vascular resistance and predisposes the patient to hypotension. Blood temperature modules are available for dialysis machines, which can provide patients with a euthermic treatment. Without such a device, the choice of dialysis solution temperature is problematic, with even small (1.1°C) differences in temperature having a notable impact on blood pressure (Sherman, 1984). The widely used dialysis solution temperature of 37°C is almost always in excess of euthermic values. Levels of 35.5°C–36.0°C are better initial choices, with adjustment made up or down depending on tolerance (chills) and effectiveness (blood pressure). Cool dialysis solutions cause patient discomfort only when the dialysate temperature is below the optimal (usually

unknown) level; eutermic dialysis is not associated with shivering and only rarely with chills (Maggiore, 2002). One group has favored individualizing dialysis solution temperature at the patient level. The tympanic membrane temperature is measured, and the dialysis solution temperature is set 0.5°C below this level. This system of individualized cooling has been shown to avoid the sensation of cold and chills commonly found with simply lowering dialysate temperature to a given level for all patients (Odudu, 2012). Individualized, cooled dialysate is associated with a shorter postdialysis recovery time, better maintenance of blood pressure, reduced myocardial stunning, and less evidence of progressive ischemia-related brain white matter damage (McIntyre, 2014).

A number of studies have found that hemodiafiltration is associated with a better tolerance to ultrafiltration and less IDH than hemodialysis. However, it appears that the beneficial effect of hemodiafiltration may have been due primarily to a lower extracorporeal circuit temperature due to the cooling effect of the replacement solution. When heat transfer from the extracorporeal circuit was kept constant, the hemodiafiltration advantage over hemodialysis with regard to blood pressure was no longer found (Kumar, 2013).

2. **Avoid intradialytic food ingestion in hypotension-prone patients.** Eating during hemodialysis can precipitate or accentuate a fall in blood pressure (Sherman, 1988; Strong, 2001). The effect is probably a result of dilation of resistance vessels in the splanchnic bed, which reduces TPR and increases splanchnic venous capacity (Barakat, 1993). The “food effect” on blood pressure probably lasts at least 2 hours. Patients who are prone to hypotension during dialysis should avoid eating just before or during a dialysis session.
3. **Minimize tissue ischemia during dialysis.** During any type of hypotensive stress, the resulting tissue ischemia causes release of adenosine. Adenosine blocks release of norepinephrine from sympathetic nerve terminals and also has intrinsic vasodilator properties. Severe hypotension can therefore amplify itself: Hypotension → ischemia → adenosine release → impaired norepinephrine release → vasodilation → hypotension.

This may be one reason for the clinical observation that patients with low hematocrit levels (e.g., <20%–25%) are very susceptible to dialysis hypotension (Sherman, 1986). Few patients currently have levels of anemia severe enough to cause hypotension. Such patients may benefit from transfusion, although the current trend is to strongly discourage transfusion of acutely ill patients in an intensive care setting. Use of nasal oxygen in hypotension-prone patients may be another way of limiting tissue ischemia and IDH (Jhawar, 2011).

4. **Midodrine.** Midodrine, an orally acting α -adrenergic agonist, reduces the frequency of IDH. A dose of 10 mg orally 1.5–2 hours before a dialysis session is typical, though use of as much as 40 mg has been reported. Supine hypertension is the major dose-limiting factor. Active cardiac ischemia (but not simply coronary artery disease) is a contraindication. Concomitant use of α -adrenergic blockers renders midodrine ineffective. No data exist as to whether the drug is especially useful in patients with

autonomic insufficiency (half of the dialysis population) as might theoretically be the case. One problem with midodrine is that its effect does not seem additive to that of using cool dialysate (Cruz, 1999).

5. **Sertraline.** At least three reports have indicated that 4 to 6 weeks of therapy with the selective serotonin reuptake inhibitor sertraline reduces the frequency of IDH. Some evidence suggests that the drug improves autonomic function (Yalcin, 2003). Like midodrine, sertraline was not shown to give added protection against IDH when cool dialysate was used (Brewster, 2003).
6. **Antihypertensive medication.** Antihypertensive medications administered prior to dialysis adversely impact the ability of the cardiovascular system to adjust to volume removal. Whether those with vasodilatory properties are more problematic than those with other mechanisms of action has not been well studied.
7. **Dialysis fluid potassium level.** A low concentration (1 mEq/L) of dialysis fluid potassium is associated with more frequent IDH, perhaps via autonomic effects. If otherwise possible, using higher potassium levels is advisable for hemodynamic benefits as well as reduced arrhythmogenic effect.
8. **Fludrocortisone.** One preliminary report (Landry, 2011) found low random aldosterone levels in a group of five dialysis patients with low predialysis blood pressures and refractory IDH. All had a normal cosyntropin test. Their blood pressures improved with fludrocortisone treatment, ultrafiltration volumes increased, and rate of IDH was reduced. There was no improvement with fludrocortisone in hypotensive patients with normal levels of adrenal hormones.
9. **Vasopressin.** Vasopressin levels normally increase with hypotension, but in dialysis patients, the increase is often suboptimal. Vasopressin preferentially constricts splanchnic vessels, and such constriction may help to redistribute blood volume centrally during fluid removal. In one study, vasopressin infusion reduced the incidence of IDH (van der Zee, 2007).

C. Hypotension related to cardiac factors

1. **Diastolic dysfunction.** A stiff, hypertrophied heart is especially prone to a reduction in output when there is even a minor reduction in filling pressure. Diastolic dysfunction is common in dialysis patients owing to the effects of hypertension, coronary artery disease, and probably uremia itself. Some limited data suggest that using verapamil as an antihypertensive agent may reduce the frequency of IDH in such patients.
2. **Heart rate and contractility.** Most, but not all, dialysis hypotension is associated with decreased cardiac filling, a setting in which cardiac compensatory mechanisms can do little to increase output. In some patients, TPR may fall (owing to temperature effects, food ingestion, or tissue ischemia) without a fall in cardiac filling. In this setting, impairment of cardiac compensatory mechanisms can play a direct role in the development of hypotension.
3. **Dialysis solution calcium.** A dialysis solution calcium concentration of 1.75 mM increases cardiac contractility and helps maintain intradialytic blood pressure better than a level of 1.25 mM, especially in patients with cardiac disease (van der Sande, 1998). However, in the chronic outpatient setting (as opposed to an intensive care

unit), symptomatic IDH is not less frequent with a higher-calcium dialysis solution (Sherman, 1986); use of high dialysis solution calcium levels may contribute to vascular calcification, and the trend is to not use them for prolonged periods. Dialysis solution magnesium levels may impact dialysis hypotension, but whether a higher or a lower level should be used is controversial (Chapter 10).

- D. **Unusual causes of hypotension during dialysis.** Rarely, hypotension during dialysis may be a sign of an underlying, serious event. Causes are listed in Table 12.1.
- E. **Detection of hypotension.** Most patients complain of feeling dizzy, light-headed, or nauseated when hypotension occurs. Some experience muscle cramps. Others may experience very subtle symptoms, which may be recognizable only to dialysis staff familiar with the patient (e.g., lack of alertness, darkening of vision); patients themselves are frequently quite aware of symptoms portending IDH. In some patients, there are no symptoms whatsoever until the blood pressure falls to extremely low (and dangerous) levels. For this reason, blood pressure must be monitored on a regular basis throughout the hemodialysis session. Whether this is done hourly, half-hourly, or on a more frequent basis depends on the individual case.
- F. **Management of IDH.** Management of the acute hypotensive episode is straightforward. The patient should be placed in the Trendelenburg position (if respiratory status allows this) and a bolus of 0.9% saline (100 mL or more, as necessary) should be rapidly administered through the blood line. The ultrafiltration rate should be reduced to as near zero as possible. The patient should then be observed carefully. Ultrafiltration can be resumed (at a slower rate, initially) once vital signs have stabilized. As an alternative to saline, glucose, mannitol, or albumin solutions can be used to treat the hypotensive episode; albumin is costly and offers little benefit over other approaches (Knoll, 2004); mannitol accumulates, reducing its benefit on subsequent treatments. IDH may respond better to rapid administration of hypertonic saline (over 2 minutes) than to slower administration (5 minutes) of (probably) an equivalent sodium load administered as 0.9% saline; the tonicity-induced increase in vasopressin levels is the likely basis for the differential effects (Shimizu, 2012). However, caution is advised if a high dialysis solution sodium is being used. Nasal oxygen administration is not generally of benefit during hypotensive episodes, though it may have value in selected patients (Jhawar, 2011).
1. **Slowing the blood flow rate.** The practice of slowing the blood flow rate during IDH developed at a time when plate dialyzers and acetate dialysis solution were in use and ultrafiltration control systems were not. The practice was believed to be beneficial because lower blood flow rates reduced (a) intradialyzer blood volume, (b) acetate (a vasodilator) transfer to the patient, (c) ultrafiltration rate, and (d) fistula “steal.” The latter refers to the belief that lowering blood flow reduces access flow and allows systemic flow to increase, a concept that is very likely incorrect except in the setting of an intra-access stenosis (Trivedi, 2005). With current dialysis practice, reduction of the blood flow rate to manage IDH is unlikely to be of any benefit. However, if hypotension is severe or unresponsive to stopping ultrafiltration and infusion of volume expanders, blood pump rates may be transiently reduced. Repeated slowing of the blood flow rate will reduce solute removal and cause underdialysis.

G. **Prevention.** One strategy to help prevent hypotension during dialysis is given in Table 12.2.

II. MUSCLE CRAMPS

A. **Etiology.** The pathogenesis of muscle cramps during dialysis is unknown. The four most important predisposing factors are hypotension, hypovolemia (patient below dry weight), high ultrafiltration rate (large weight gain), and use of low-sodium dialysis solution. These factors all tend to favor vasoconstriction, resulting in muscle hypoperfusion, leading to secondary impairment of muscle relaxation. Muscle cramps most commonly occur in association with hypotension, although cramps often persist after seemingly adequate blood pressure has been restored. The frequency of cramping increases logarithmically with the weight loss requirements; weight losses of 2%, 4%, and 6% have been associated with cramping frequencies of 2%, 26%, and 49%, respectively.

TABLE

12.2

Strategy to Help Prevent Hypotension During Dialysis

1. Use a dialysis solution temperature of 35.5°C or individualize and set dialysis solution temperature at 0.5°C below the patient's average predialysis tympanic membrane temperature.
2. Review dietary sodium intake and any other reasons for excess fluid intake. Fluid intake should ideally be <1 L per day in anuric patients. If predialysis serum sodium is low, consider the level of dialysis solution sodium versus serum sodium.
3. If substantial residual kidney function exists, consider increasing urine volume using diuretics.
4. Extend weekly dialysis time if ultrafiltration rate is >13 mL / kg per hour.
5. Consider raising the patient's target weight.
6. In refractory cases, consider a trial of higher (140–145 mM) dialysis sodium, as tolerated, especially if a high IDWG is not a problem. If a high IDWG is present, consider cautiously lowering dialysis sodium level.
7. Give daily dose of antihypertensive medications after, not before, dialysis; change therapy to shorter-acting agents.
8. Assess the benefits of a predialysis hemoglobin level consistently = 10–11 g/dL (100–110 g/L).
9. Do not give food or glucose orally during, or immediately preceding, dialysis to hypotension-prone patients.
10. Consider use of a blood volume monitor.
11. Consider a trial of midodrine or sertraline.
12. Consider use of a higher (e.g., 3.0 mM) potassium dialysis solution if predialysis levels allow.

Cramping is more common during the first month of dialysis than in subsequent periods. It is more common in patients with a low cardiac index. Diagnostically obscure elevations in serum creatinine phosphokinase levels on routine monthly laboratory tests may result from intradialytic muscle cramping. Hypomagnesemia may cause treatment-resistant muscle cramping during dialysis. Hypocalcemia should also be considered as a potential cause,

especially in patients treated with relatively low-calcium dialysis solution (1.25 mM) and calcium-free phosphate binders and/or cinacalcet. Predialysis hypokalemia will be exacerbated by the usual level of dialysis solution potassium (2 mM) and may precipitate cramping as well.

- B. **Management.** When hypotension and muscle cramps occur concomitantly, both may respond to treatment with 0.9% saline; however, it is not unusual for muscle cramps to persist. Hypertonic solutions (saline, glucose, mannitol) may be more effective in dilating muscle blood vessels. These solutions are more effective in the acute management of muscle cramps. Because the concentrated sodium load associated with hypertonic saline administration can be problematic, hypertonic glucose administration is preferred for treatment of cramps in nondiabetic patients (Sherman, 1982). Mannitol may accumulate in dialysis patients, particularly when administered late in treatment—the usual time for the occurrence of cramps. Nifedipine (10 mg) sometimes can reverse cramping. Though reportedly not causing a notable fall in blood pressure, nifedipine should be reserved for cramping in hemodynamically stable patients. Forced stretching of the muscle involved (e.g., ankle flexion for calf cramping) may provide relief. Massage varies in its utility on an individual basis.
- C. **Prevention.** Prevention of hypotensive episodes will eliminate most cramping.
1. **Stretching exercises.** A program of stretching exercises targeted at the affected muscle groups may be useful and should be the first-line treatment for both dialysis-related cramps and nocturnal cramps (Evans, 2013).
 2. **Dialysate sodium.** The frequency of cramping is inversely related to the dialysis solution sodium level. Raising sodium levels to just below the threshold for induction of postdialysis thirst will be beneficial, and use of sodium gradient dialysis can definitely reduce cramps, although sometimes at the expense of increasing IDWG and blood pressure.
 3. **Dialysate magnesium.** Avoiding low predialysis levels of magnesium, calcium, and potassium may also be helpful. In one preliminary study, use of 0.5 mM (1 mEq/L) dialysis solution magnesium was associated with a lower incidence of cramps than when 0.375 mM (0.75 mEq/L) solution was used (Movva, 2011). Magnesium supplements have not been shown to be useful in nonuremic subjects, and magnesium should be given with great caution to dialysis patients. The use of Osveren (calcium acetate/magnesium carbonate) as a phosphate binder compared with sevelamer showed no change in the incidence of cramps.
 4. **Biotin.** Biotin, in a dose of 1 mg per day, has been reported to improve intradialytic cramps, despite baseline serum levels being higher than in control subjects (Oguma, 2012). This study needs to be confirmed before biotin use can be more widely recommended.
 5. **Carnitine, oxazepam, and vitamin E.** Carnitine supplementation of dialysis patients may reduce intradialytic muscle cramps (Ahmad, 1990) as may oxazepam (5–10 mg, given 2 hours prior to dialysis) and vitamin E. See Evans (2013) for a review.
 6. **Compression devices.** A type of sequential compression device may be of benefit (Ahsan, 2004).

7. **Quinine.** Quinine sulfate before dialysis, though effective in preventing intradialytic cramps, is now considered inadvisable because of its association with thrombocytopenia, hypersensitivity reactions, and QT prolongation. The FDA has issued a number of guidance documents aimed at counseling health professionals against use of quinine for leg cramps.

III. NAUSEA AND VOMITING

- A. **Etiology.** Nausea or vomiting occurs in up to 10% of routine dialysis treatments. The cause is multifactorial. Most episodes in stable patients are probably related to hypotension. Nausea or vomiting can also be an early manifestation of the disequilibrium syndrome described below. Both type A and type B varieties of dialyzer reactions can cause nausea and vomiting. Gastroparesis, very common in diabetes but also seen in nondiabetic patients, is exacerbated by hemodialysis and may play a role in some patients. Contaminated or incorrectly formulated dialysis solution (high sodium, calcium) may cause nausea and vomiting as part of a constellation of symptoms. Dialysis patients appear to develop nausea and vomiting more readily than other patients (e.g., with an upper respiratory infection, narcotic usage, hypercalcemia); dialysis may precipitate these symptoms in such a predisposing setting.
- B. **Management.** The first step is to treat any associated hypotension. Vomiting may be particularly problematic when associated with a hypotension-induced reduction in the level of consciousness owing to the risk of aspiration. Antiemetics can be administered for other causes of vomiting as needed.
- C. **Prevention.** Avoidance of hypotension during dialysis is of prime importance. Persistent symptoms unrelated to hemodynamics may benefit from metoclopramide. Sometimes a single predialysis dose of 5–10 mg is sufficient.

IV. HEADACHE

- A. **Etiology.** Headache occurs in as many as 70% of patients during dialysis; its cause is largely unknown. It may be a subtle manifestation of the disequilibrium syndrome (see section VII, below). In patients who are coffee drinkers, headache may be a manifestation of caffeine withdrawal as the blood caffeine concentration is acutely reduced during the dialysis treatment. Dialysis may precipitate migraine headaches in those with a history of the disorder. With atypical or particularly severe headache, a neurologic cause (particularly a bleeding event precipitated by anticoagulation) should be considered.
- B. **Management.** Acetaminophen can be given during dialysis.
- C. **Prevention.** Decreasing dialysis solution sodium may also be helpful in patients being treated with high sodium levels. A cup of strong coffee may help prevent (or treat) caffeine withdrawal symptoms. Patients suffering from headache during dialysis may be magnesium deficient (Goksel, 2006). A cautious trial of magnesium supplementation may be indicated, keeping in mind the risks of giving magnesium to patients with renal failure.

- V. **CHEST PAIN AND BACK PAIN.** Mild chest pain or discomfort (often associated with some back pain) occurs in 1%–4% of dialysis treatments. The cause is unknown. There is no specific

management or prevention strategy, though switching to a different variety of dialyzer membrane may be of benefit. The occurrence of angina during dialysis is common and must be considered in the differential diagnosis, along with numerous other potential causes of chest pain (e.g., hemolysis, air embolism, pericarditis). The management and prevention of angina is discussed in Chapter 38.

VI. **ITCHING.** Itching, a common problem in dialysis patients, is sometimes precipitated or exacerbated by dialysis. Itching appearing only during the treatment, especially if accompanied by other minor allergic symptoms, may be a manifestation of low-grade hypersensitivity to dialyzer or blood circuit components. More often than not, however, itching is simply present chronically, and is noticed in the course of the treatment while the patient is forced to sit still for a prolonged period of time. Viral (or drug-induced) hepatitis and scabies should not be overlooked as potential causes of such itching.

Chronically, general moisturizing and lubrication of the skin using emollients is recommended, and this should be the first line of therapy. One should make sure that dialysis is adequate, and that a Kt/V of at least 1.2 and possibly higher is being delivered, though the evidence that higher Kt/V improves pruritus is not strong. Pruritus is often found in patients with elevated serum calcium or phosphorus levels and/or substantially elevated parathyroid hormone (PTH) level; reductions in phosphorus, calcium (to the lower end of the normal range), and PTH levels are indicated.

Standard symptomatic treatment using antihistamines is useful. Gabapentin (or pregabalin), UVB (ultraviolet light B) therapy, oral charcoal, or nalfurafine might be the next line of therapy, followed by naltrexone or tacrolimus ointment (Figure 12.1) (Mettang and Kremer, 2014).

VII. DISEQUILIBRIUM SYNDROME

A. **Definition.** The disequilibrium syndrome is a set of systemic and neurologic symptoms often associated with characteristic electroencephalographic findings that can occur either during or following dialysis. Early manifestations include nausea, vomiting, restlessness, and headache. More serious manifestations include seizures, obtundation, and coma (see also Chapter 40).

B. **Etiology.** The cause of the disequilibrium syndrome is controversial. Most believe it is related to an acute increase in brain water content. When the plasma solute level is rapidly lowered during dialysis, the plasma becomes hypotonic with respect to the brain cells, and water shifts from the plasma into brain tissue. Others incriminate acute changes in the pH of the cerebrospinal fluid during dialysis as the cause of this disorder.

The disequilibrium syndrome was a much larger problem two or more decades ago, when acutely uremic patients with very high serum urea nitrogen values were commonly subjected to prolonged dialysis. However, milder forms of the syndrome may still occur in long-term dialysis patients, manifesting as nausea, vomiting, or headache. The full-blown disequilibrium syndrome, including coma and/or seizures, can still be precipitated when an acutely uremic patient is dialyzed too energetically.

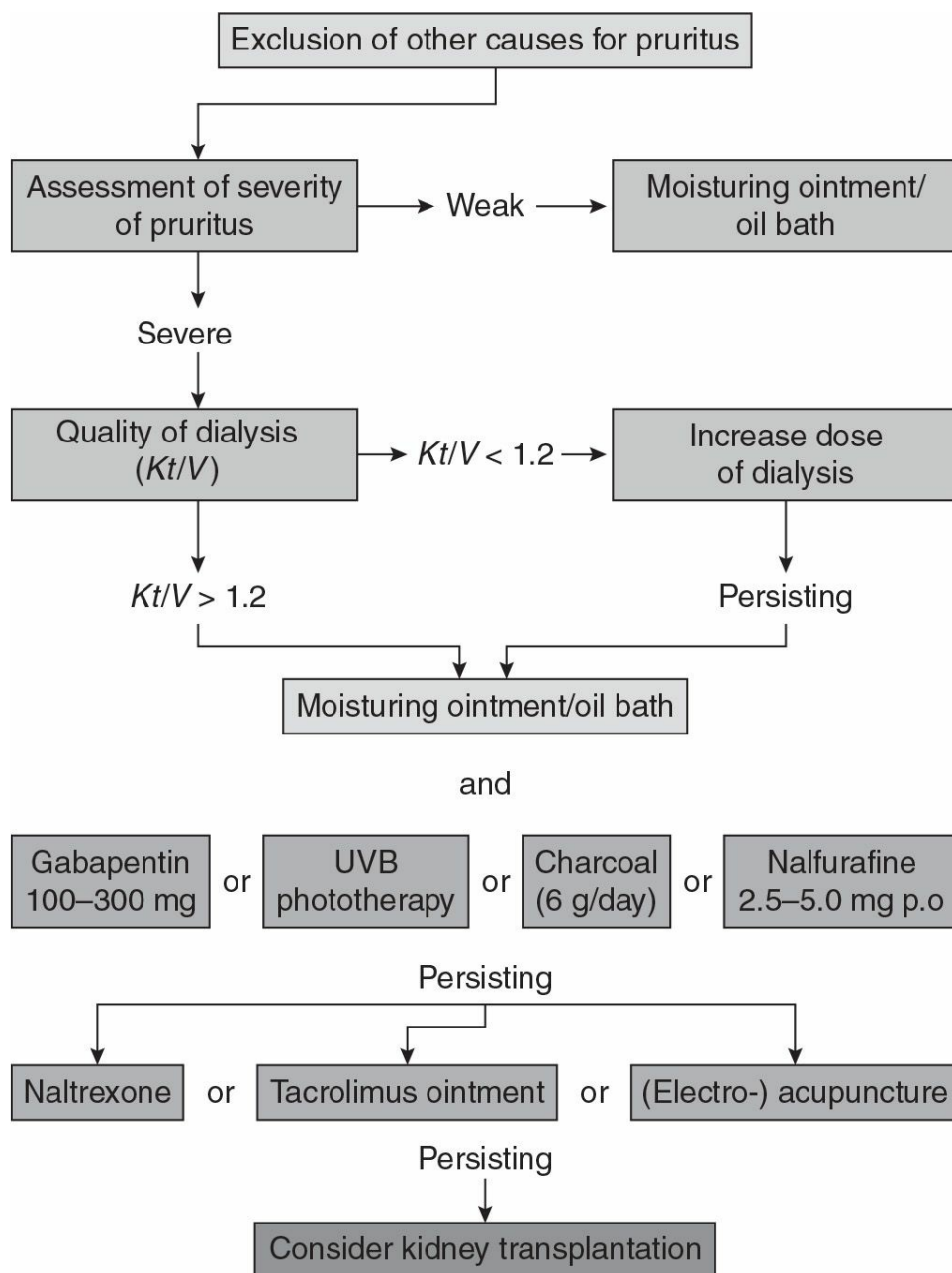

FIGURE 12.1 Algorithm to manage pruritus. UVB = ultraviolet light B. (Reproduced with permission from Mettang T, Kremer AE. Uremic pruritus. *Kidney Int.* 2014).

C. Management

1. **Mild disequilibrium.** Symptoms of nausea, vomiting, restlessness, and headache are nonspecific; when they occur, it is difficult to be certain that they are due to disequilibrium. Treatment is symptomatic. If mild symptoms of disequilibrium develop in an acutely uremic patient during dialysis, the blood flow rate should be reduced to decrease the efficiency of solute removal and pH change, and consideration should be given to terminating the dialysis session earlier than planned. Hypertonic sodium chloride or glucose solutions can be administered as for treatment of muscle cramps.
2. **Severe disequilibrium.** If seizures, obtundation, or coma occur in the course of a dialysis session, dialysis should be stopped. The differential diagnosis of severe disequilibrium syndrome should be considered (see Chapter 40). Treatment of seizures is discussed in Chapter 40. The management of coma is supportive. The airway should be controlled and the patient ventilated if necessary. Intravenous mannitol may be of

benefit. If coma is due to disequilibrium, then the patient should improve within 24 hours.

D. **Prevention**

1. **In an acute dialysis setting.** When planning dialysis for an acutely uremic patient, one should not prescribe an overly aggressive treatment session (see Chapter 10). The target reduction in the plasma urea nitrogen level should initially be limited to about 40%. Use of a low-sodium dialysis solution (more than 2–3 mM less than the plasma sodium level) may exacerbate cerebral edema and should be avoided. In hypernatremic patients, one should not attempt to correct the plasma sodium concentration and the uremia at the same time. It is safest to dialyze a hypernatremic patient initially with a dialysis solution sodium value close to the plasma level and then to correct the hypernatremia slowly postdialysis by administering 5% dextrose.
2. **In a chronic dialysis setting.** The incidence of disequilibrium syndrome can be minimized by use of a dialysis solution with a sodium concentration of at least 140 mM. Intradialytic symptom frequency has been shown to be similar with a dialysate glucose concentration of 200 versus 100 mg/dL (11 vs. 5.5 mM) (Raimann, 2012). Using a high dialysis solution sodium concentration (145–150 mM) that declines over the course of treatment for patients has been advocated in this setting: the initially high dialysis solution sodium results in a rising plasma sodium that may counteract the osmotic effects of the initially rapid removal of urea and other solutes from plasma. There is evidence that use of this approach reduces the incidence of disequilibrium-type intradialytic symptoms, but it may increase IDWG and blood pressure because of diffusive entry of sodium from dialysis solution to blood during the treatment session.

VIII. **DIALYZER REACTIONS.** This is a broad group of events that includes both anaphylactic and less well-defined adverse reactions of unknown cause (Jaber and Pereira, 1997). In the past, many of these reactions were grouped under the term “first-use” syndrome because they presented much more often when new (as opposed to reused) dialyzers were employed. However, similar reactions occur with reused dialyzers, and we now discuss them under the more general category used here. There appear to be two varieties: an anaphylactic type (type A) and a nonspecific type (type B). The occurrence of type B reactions appears to have diminished considerably during the past several decades.

A. **Type A (anaphylactic type)**

1. **Manifestations.** When a full-blown, severe reaction occurs, the manifestations are those of anaphylaxis. Dyspnea, a sense of impending doom, and a feeling of warmth at the fistula site or throughout the body are common presenting symptoms. Cardiac arrest and even death may supervene. Milder cases may present only with itching, urticaria, cough, sneezing, coryza, or watery eyes. Gastrointestinal manifestations, such as abdominal cramping or diarrhea, may also occur. Patients with a history of atopy and/or with eosinophilia are prone to develop these reactions. Symptoms usually begin during the first few minutes of dialysis, but onset may occasionally be delayed for up to 30 minutes or more.
2. **Etiology**

- a. **Ethylene oxide.** Most type A (anaphylactic) reactions in the past were due to hypersensitivity reactions to ethylene oxide, which was widely used by manufacturers to sterilize dialyzers. It tended to accumulate in the potting compound used to anchor the hollow fibers, hampering efforts to remove it by degassing prior to sale. These reactions were observed exclusively during first use of dialyzers. Manufacturers currently use a variety of methods of sterilization (gamma radiation, steam, electron beam) , and when ethylene oxide is used, little residual compound is left in the dialyzers. As a result, ethylene oxide reactions are now uncommon.
- b. **AN69-associated reactions.** These were initially reported in patients dialyzed with the AN69 (acrylonitrile-sodium methallyl sulfonate) membrane who were also taking angiotensin-converting enzyme (ACE) inhibitors. The reactions are thought to be mediated by the bradykinin system. The negatively charged AN69 membrane activates the bradykinin system with the effects magnified because ACE inhibitors block bradykinin inactivation. Plasma bradykinin levels, higher at baseline in patients treated with AN69 dialyzers, rise substantially during reactions. The bradykinin effect should be less pronounced with angiotensin receptor blockers than with ACE inhibitors (Ball, 2003). It is unclear to what extent ACE inhibitor-associated reactions occur with other PAN (polyacrylonitrile)-based membranes or with other non-PAN-based membranes.
- c. **Contaminated dialysis solution.** Type A dialyzer reactions may be accounted for in some instances by dialysis solution contamination with high levels of bacteria and endotoxin, particularly with the use of high-flux dialyzers. Such reactions are likely to occur promptly (within 2 minutes) of initiating dialysis; complement-mediated reactions are more delayed (15–30 minutes) in onset. Fever and chills are particularly common symptoms with these reactions. The higher the bacteria and endotoxin levels are, the greater the risk is of a reaction.
- d. **Reuse.** Clusters of anaphylactic-type dialyzer reactions have occurred in a reuse setting. The problem has often been linked to inadequate dialyzer disinfection during the reuse procedure, but in many cases the cause is unknown. Half of Centers for Disease Control and Prevention (CDC) investigations of outbreaks of bacteremia or pyrogenic reactions in dialysis patients over a 20-year period were ascribed to dialyzer reuse problems (Roth and Jarvis, 2000).
- e. **Heparin.** Heparin has occasionally been associated with allergic reactions, including urticaria, nasal congestion, wheezing, and even anaphylaxis. When a patient seems to be allergic to a variety of different dialyzers regardless of the sterilization mode, and dialysis solution contamination also has been reasonably excluded, a trial of heparin-free dialysis or citrate anticoagulation should be considered. Low-molecular-weight heparins are not a safe substitute in such patients owing to cross-reactivity with heparin, which may

result in anaphylactic reactions.

- f. **Complement fragment release.** Acute increases in pulmonary artery pressure have been documented in both animals and humans during dialysis with unsubstituted cellulose membranes. However, there is no good evidence that complement activation causes type A dialyzer reactions. Several studies have found no difference in type A reaction rates between membranes that readily activate complement (cuprophane) and those that do not (polysulfone, AN69).
 - g. **Eosinophilia.** Type A reactions tend to occur more readily in patients with mild to moderate eosinophilia. Very severe reactions to dialysis or plasmapheresis were reported in patients with very high eosinophil counts; these were thought to be due to sudden eosinophil degranulation with release of bronchoconstrictive and other mediators.
3. **Management.** Identifying the actual cause of a dialyzer reaction frequently is not possible. It is safest to stop dialysis immediately, clamp the blood lines, and discard the dialyzer and blood lines *without returning the contained blood*. Immediate cardiorespiratory support may be required. According to the severity of the reaction, treatment with intravenous antihistamines, steroids, and epinephrine can be given.
 4. **Prevention.** For all patients, proper rinsing of dialyzers prior to use is important to eliminate residual ethylene oxide and other putative allergens. In a patient with a history of type A reaction to an ethylene oxide–sterilized dialyzer, the dialyzer type can be changed to a γ -irradiated, steam-sterilized, or electron beam–sterilized dialyzer (see Table 4.1). The necessity of using non–ethylene oxide–sterilized blood lines when switching to a dialyzer sterilized by some alternate method has not been established. For patients whose mild type A symptoms persist following a switch to equipment free of ethylene oxide, predialysis administration of antihistamines may be of benefit. Placing the patient on a reuse program and subjecting even new dialyzers to the reuse procedure prior to first use may be of benefit because of enhanced washout of potential noxious substances or allergens. Changing or stopping heparin, trying a less complement-activating membrane, and substituting an angiotensin receptor–blocking agent for an ACE inhibitor may also be tried. A role for latex exposure during dialysis initiation in a sensitized patient should be considered as well.

B. **Nonspecific type B dialyzer reactions**

1. **Symptoms.** The principal manifestations of a type B reaction are chest pain, sometimes accompanied by back pain. Symptom onset is usually 20–40 minutes after starting dialysis. Typically, type B reactions are much less severe than type A reactions.
2. **Etiology.** The cause is unknown. Complement activation has been suggested to be a culprit, but its etiologic role in the development of these symptoms is uncertain. Chest and back pain may occur less frequently with reused dialyzers than with new dialyzers, though this is controversial. Any beneficial effects may be due to increased biocompatibility from protein coating of the membrane (not seen with bleach reprocessing) or to washout of potentially toxic substances from the dialyzer. Other causes of chest and back pain must be excluded, and the diagnosis of a type B dialyzer

reaction is one of exclusion. In particular, subclinical hemolysis must be ruled out. A syndrome of acute respiratory distress associated with heparin-induced thrombocytopenia has been described (Popov, 1997), which may superficially resemble a type B dialyzer reaction.

3. **Management.** Management is supportive. Nasal oxygen should be given. Myocardial ischemia should be considered, and angina pectoris, if suspected, can be treated as discussed in Chapter 38. Dialysis can usually be continued, as symptoms invariably abate after the first hour.
4. **Prevention.** Trying a different dialyzer membrane may be of value.

IX. HEMOLYSIS. Acute hemolysis during dialysis may be a medical emergency.

- A. **Manifestations:** The symptoms of hemolysis are back pain, tightness in the chest, and shortness of breath. A dramatic deepening of skin pigmentation may occur. Common are a port-wine appearance of blood in the venous blood line, a pink discoloration of the plasma in centrifuged blood samples, and a marked fall in the hematocrit. If massive hemolysis is not detected early, then hyperkalemia can result owing to release of potassium from the hemolyzed erythrocytes, leading to muscle weakness, electrocardiographic abnormalities, and, ultimately, cardiac arrest.
- B. **Etiology.** Acute hemolysis has been reported in two primary settings: (a) an obstruction or narrowing in the blood line, catheter, or needle or (b) a problem with the dialysis solution. The possibility of hemolysis induced by the combination of G6PD deficiency and predialysis quinine sulfate therapy should be considered.
 1. **Blood line obstruction/narrowing.** Kinks may develop in the arterial blood line (Sweet, 1996). An epidemic of hemolysis also has been reported owing to manufacturing defects in the link between the dialyzer outlet blood line and the venous air trap chamber (CDC, 1998). Hemolysis (usually subclinical) may also appear when blood flow rate is high and relatively small needle sizes are used (De Wachter, 1997). Routine blood line pressure monitoring will call attention to many, but not all, such problems.
 2. Problems **with dialysis solution.** These are as follows:
 - a. Overheated dialysis solution
 - b. Hypotonic dialysis solution (insufficient concentrate-to-water ratio)
 - c. Dialysis solution contaminated with formaldehyde, bleach, chloramine (from city water supply), copper (from copper piping), fluoride, nitrates (from water supply), zinc, or hydrogen peroxide (see Chapter 5).
- C. **Management.** The blood pump should be stopped immediately and the blood lines clamped. The hemolyzed blood has a very high potassium content and should not be reinfused. One should be prepared to treat the resultant hyperkalemia and possible drop in hematocrit. The patient should be observed carefully, and hospitalization should be considered. Delayed hemolysis of injured erythrocytes may continue for some time after the dialysis session. Severe hyperkalemia may occur, and this may require additional dialysis or other measures (e.g., administration of an Na/K ion exchange resin by mouth or rectum) to control. A complete blood count, reticulocyte count, and levels of haptoglobin, free

hemoglobin, lactate dehydrogenase (LDH), and methemoglobin should be obtained. Dialysis solution water (chloramine, nitrates, metals) and, if reprocessed, the dialyzer (residual sterilant) need to be assessed as well.

- D. **Prevention.** Unless the problem is an obstruction in the blood path or faulty roller pump causing excessive blood trauma, the cause of the hemolysis must be assumed to be in the dialysis solution, and samples of dialysis solution must be investigated to determine the cause.

X. **AIR EMBOLISM.** Air embolism is a potential catastrophe that can lead to death unless detected and treated quickly.

A. **Manifestations**

1. **Symptoms.** These depend to an extent on the position of the patient. In seated patients, infused air tends to migrate into the cerebral venous system without entering the heart, causing obstruction to cerebral venous return, loss of consciousness, convulsions, and even death. In recumbent patients, the air tends to enter the heart, generate foam in the right ventricle, and pass into the lungs, producing dyspnea, cough, and chest tightness and arrhythmias. Further passage of air across the pulmonary capillary bed into the left ventricle can result in air embolization to the arteries of the brain and heart, with acute neurologic and cardiac dysfunction.
2. **Signs.** Foam is often seen in the venous blood line of the dialyzer. If air has gone into the heart, a peculiar churning sound may be heard on auscultation.

B. **Etiology.** The predisposing factors and possible sites of air entry have been discussed in Chapter 4. The most common sites of air entry are the arterial needle, the prepump arterial tubing segment, and an inadvertently opened end of a central venous catheter.

C. **Management.** The first step is to clamp the venous blood line and stop the blood pump. The patient is immediately placed in a recumbent position on the left side with the chest and head tilted downward. Further treatment includes cardiorespiratory support, including administration of 100% oxygen by mask or endotracheal tube. Aspiration of air from the atrium or ventricle with a percutaneously inserted needle or cardiac catheterization may be needed if the volume of air warrants it.

D. **Prevention.** See Chapters 4 and 10.

XI. **OTHER COMPLICATIONS:** Arrhythmia and cardiac tamponade are discussed in Chapter 38. Severe disequilibrium syndrome, seizures, and intracerebral bleed are discussed in Chapter 40.

References and Suggested Readings

- Ahmad S, et al. Multicenter trial of L-carnitine in maintenance hemodialysis patients. II. Clinical and biochemical effects. *Kidney Int.* 1990;38:912–918.
- Ahsan M, et al. Prevention of hemodialysis-related muscle cramps by intradialytic use of sequential compression devices: a report of four cases. *Hemodial Int.* 2004;8:283–286.
- Brewster UC, et al. Addition of sertraline to other therapies to reduce dialysis-associated hypotension. *Nephrology (Carlton).* 2003;8:296–301.

- Brunet P, et al. Tolerance of haemodialysis: a randomized cross-over trial of 5-h versus 4-h treatment time. *Nephrol Dial Transplant*. 1996;11(suppl 8):46–51.
- Centers for Disease Control and Prevention (CDC). Multistate outbreak of hemolysis in hemodialysis patients. *JAMA*. 1998;280:1299.
- Chang TI, et al. Intradialytic hypotension and vascular access thrombosis. *J Am Soc Nephrol*. 2011;22:1526–1533.
- Che-yi C, et al. Acupuncture in haemodialysis patients at the Quchi acupoint for refractory uremic pruritus. *Nephrol Dial Transplant*. 2005;20:1912–1915.
- Cruz DN, et al. Midodrine and cool dialysis solution are effective therapies for symptomatic intradialytic hypotension. *Am J Kidney Dis*. 1999;33:920–926.
- Curatola G, et al. Ultrafiltration intensification in hemodialysis patients improves hypertension but increases AV fistula complications and cardiovascular events. *J Nephrol*. 2011;24:465–473.
- Davenport A. Using dialysis machine technology to reduce intradialytic hypotension. *Hemodial Int*. 2011;15:S37.
- Davenport A, et al. Achieving blood pressure targets during dialysis improves control but increases intradialytic hypotension. *Kidney Int*. 2008;73:759–764.
- Daugirdas JT. Dialysis hypotension: a hemodynamic analysis. *Kidney Int*. 1991;39:233–246.
- Daugirdas JT, Ing TS. First-use reactions during hemodialysis: a definition of subtypes. *Kidney Int*. 1988;24:S37–S43.
- De Wachter DS, et al. Blood trauma in plastic haemodialysis cannulae. *Int J Artif Organs*. 1997;20:366–370.
- Evans EC. Hemodialysis-related cramps and nocturnal leg cramps—what is best practice? *Nephrol Nurs J*. 2013;40:549–553.
- Evans RD, Rosner M. Ocular abnormalities associated with advanced kidney disease and hemodialysis. *Semin Dial*. 2005;18:252–257.
- Flythe J, et al. Association of mortality risk with various definitions of intradialytic hypotension. *J Am Soc Nephrol*. 2014; in press.
- Franssen CFM. Adenosine and dialysis hypotension. *Kidney Int*. 2006;69:789–791.
- Geller AB, et al. Increase in post-dialysis hemoglobin can be out of proportion and unrelated to ultrafiltration. *Dial Transplant*. 2010;39:57
- Goksel BK, et al. Is low blood magnesium level associated with hemodialysis headache? *Headache*. 2006;46:40–45.
- Gunal AL, et al. Gabapentin therapy for pruritus in hemodialysis patients: a randomized placebo-controlled, double-blind trial. *Nephrol Dial Transplant*. 2004;19:3137–3139.
- Gwinner W, et al. Life-threatening complications of extracorporeal treatment in patients with severe eosinophilia. *Int J Artif Organs*. 2005;28:1224–1227.
- Herrero JA, et al. Pulmonary diffusing capacity in chronic dialysis patients. *Respir Med*. 2002;96:487–492.
- Huang CC, et al. Oxygen, arterial blood gases and ventilation are unchanged during dialysis in patients receiving pressure support ventilation. *Respir Med*. 1998;92:534.
- Hur E, Usta M, Toz H, et al. Effect of fluid management guided by bioimpedance spectroscopy on cardiovascular parameters in hemodialysis patients: a randomized controlled trial. *Am J Kidney Dis*. 2013;61:857–965.

- Jaber BL, Pereira JBG. Dialysis reactions. *Semin Dial*. 1997;10:158–165.
- Jansen PH, et al. Randomised controlled trial of hydroquinine in muscle cramps. *Lancet*. 1997;349:528.
- Jefferies HJ, et al. Frequent hemodialysis schedules are associated with reduced levels of dialysis-induced cardiac injury (myocardial stunning). *Clin J Am Soc Nephrol*. 2011;6:1326–1332.
- Jhawar N, et al. Effect of oxygen therapy on hemodynamic stability during hemodialysis with continuous blood volume and O₂ saturation monitoring [abstract]. *J Am Soc Nephrol*. 2011;22:812A.
- Kimata N, et al. Pruritus in hemodialysis patients: results from the Japanese Dialysis Outcomes and Practice Patterns Study (JDOPPS). *Hemodial Int*. 2014;18:657–67.
- Kitano Y, et al. Severe coronary stenosis is an important factor for induction and lengthy persistence of ventricular arrhythmias during and after hemodialysis. *Am J Kidney Dis*. 2004;44:328–336.
- Knoll GA, et al. A randomized, controlled trial of albumin versus saline for the treatment of intradialytic hypotension. *J Am Soc Nephrol*. 2004;15:487–492.
- Ko MJ, et al. Narrowband ultraviolet B phototherapy for patients with refractory uraemic pruritus: a randomized controlled trial. *Br J Dermatology*. 2011;165:633.
- Krieter DH, et al. Anaphylactoid reactions during hemodialysis in sheep are ACE inhibitor dose-dependent and mediated by bradykinin. *Kidney Int*. 1998;53:1026–1035.
- Kumar S, et al. Haemodiafiltration results in similar changes in intracellular water and extracellular water compared to cooled haemodialysis. *Am J Nephrol*. 2013;37:320–324.
- Landry DL, Hosseini SS, Osagie OJ, et al. Aldosterone deficiency as the cause of intradialytic hypotension and its successful management with fludricortisone [abstract]. *J Am Soc Nephrol*. 2011;22:94.
- Lemes HP, et al. Use of small doses of furosemide in chronic kidney disease patients with residual renal function undergoing hemodialysis. *Clin Exp Nephrol*. 2011;15:554–559.
- Lemke H-D, et al. Hypersensitivity reactions during haemodialysis: role of complement fragments and ethylene oxide antibodies. *Nephrol Dial Transplant*. 1990;5:264.
- Locatelli F, et al.; The Italian Cooperative Dialysis Study Group. Effects of different membranes and dialysis technologies on patient treatment tolerance and nutritional parameters. *Kidney Int*. 1996;50:1293–1302.
- Maggiore Q, et al. The effects of control of thermal balance on vascular stability in hemodialysis patients: results of the European randomized clinical trial. *Am J Kidney Dis*. 2002;40:280–290.
- Marshall MR, Dunlop JL. Are dialysate sodium levels too high? *Semin Dial*. 2012;25:277.
- McCausland FR, et al. Increased dietary sodium is independently associated with greater mortality among prevalent hemodialysis patients. *Kidney Int*. 2012;82:204–211.
- McIntyre CW, Odudu A. Hemodialysis-associated cardiomyopathy: a newly defined disease entity. *Semin Dial*. 2014;27:87–97.
- Mettang T, Kremer AE. Uremic pruritus. *Kidney Int*. 2014.
- Movva S, Lynch PG, Wadhwa NK. Interaction of potassium, sodium with higher magnesium dialysate on muscle cramps in chronic hemodialysis patients [abstract]. *J Am Soc Nephrol*. 2011; 22:810A.
- Najafabadi MM, et al. Zinc sulfate for relief of pruritus in patients on maintenance hemodialysis. *Ther Apher Dial*. 2012;16:142.
- Narita I, et al. Etiology and prognostic significance of severe uremic pruritus in chronic hemodialysis

patients. *Kidney Int.* 2014;69:1626–1632.

- Odudu A, et al. Rationale and design of a multi-centre randomised controlled trial of individualised cooled dialysate to prevent left ventricular systolic dysfunction in haemodialysis patients. *BMC Nephrol.* 2012;13:45.
- Oguma S, et al. Biotin ameliorates muscle cramps of hemodialysis patients: a prospective trial. *Tohoku J Exp Med.* 2012;227:217–223.
- Parker TF, et al. Effect of the membrane biocompatibility on nutritional parameters in chronic hemodialysis patients. *Kidney Int.* 1996;49:551–556.
- Parnes EL, Shapiro WB. Anaphylactoid reactions in hemodialysis patients treated with the AN69 dialyzer. *Kidney Int.* 1991;40:1148.
- Pegues DA, et al. Anaphylactoid reactions associated with reuse of hollow-fiber hemodialyzers and ACE inhibitors. *Kidney Int.* 1992;42:1232.
- Poldermans D, et al. Cardiac evaluation in hypotension-prone and hypotension-resistant dialysis patients. *Kidney Int.* 1999;56:1905–1911.
- Popov D, et al. Pseudopulmonary embolism: acute respiratory distress in the syndrome of heparin-induced thrombocytopenia. *Am J Kidney Dis.* 1997;29:449–452.
- Raimann JG, et al. Metabolic effects of dialyzate glucose in chronic hemodialysis: results from a prospective, randomized crossover trial. *Nephrol Dial Transplant.* 2012;27:1559–1568.
- Reddan DN, et al. Intradialytic blood volume monitoring in ambulatory hemodialysis patients: a randomized trial. *J Am Soc Nephrol.* 2005;16:2162–2169.
- Ritz E, et al. Cardiac changes in uraemia and their possible relationship to cardiovascular instability on dialysis. *Nephrol Dial Transpl.* 1990;5:93–97.
- Roth VR, Jarvis WR. Outbreaks of infection and/or pyrogenic reactions in dialysis patients. *Semin Dial.* 2000;13:92–96.
- Santos SFF, Peixoto AJ. Sodium balance in maintenance hemodialysis. *Semin Dial.* 2010;23:549
- Sav MY, Sav T, Senocak E, et al. Hemodialysis-related headache. *Hemodial Int.* 2014.
- Selby NM, McIntyre CW. A systematic review of the clinical effects of reducing dialysate fluid temperature. *Nephrol Dial Transplant.* 2006;21:1883–1898.
- Seukeran D, et al. Sudden deepening of pigmentation during haemodialysis due to severe haemolysis. *Br J Dermatol.* 1997;137:997–999.
- Shah A, Davenport A. Does a reduction in dialysate sodium improve blood pressure control in haemodialysis patients? *Nephrology (Carlton).* 2012;17:358–363.
- Sherman RA, et al. Effect of variations in dialysis solution temperature on blood pressure during hemodialysis. *Am J Kidney Dis.* 1984;4:66–68.
- Sherman RA, et al. The effect of dialysis solution calcium levels on blood pressure during hemodialysis. *Am J Kidney Dis.* 1986;8:244–227.
- Sherman RA, et al. The effect of red cell transfusion on hemodialysis-related hypotension. *Am J Kidney Dis.* 1988;11:33–35.
- Sherman RA, et al. Postprandial blood pressure changes during hemodialysis. *Am J Kidney Dis.* 1988;12:37–39.
- Shimizu K, et al. Vasopressin secretion by hypertonic saline infusion during hemodialysis: effect of cardiopulmonary recirculation. *Nephrol Dial Transplant.* 2012;27:796–803.
- Silver SM, et al. Dialysis disequilibrium syndrome (DDS) in the rat: role of the “reverse urea effect.”

Kidney Int. 1992;42:161–166.

- Steuer RR, et al. Reducing symptoms during hemodialysis by continuously monitoring the hematocrit. *Am J Kidney Dis.* 1996;27:525–532.
- Stiller S, et al. A critical review of sodium profiling for hemodialysis. *Semin Dial.* 2001;14:337–347.
- Straumann E, et al. Symmetric and asymmetric left ventricular hypertrophy in patients with end-stage renal failure on long-term hemodialysis. *Clin Cardiol.* 1998;21:672–678.
- Sweet SJ. Hemolytic reactions mechanically induced by kinked hemodialysis lines. *Am J Kidney Dis.* 1996;27:262–266.
- Tomson CRV. Advising dialysis patients to restrict fluid intake without restricting sodium intake is not based on evidence and is a waste of time. *Nephrol Dial Transplant.* 2001;16:1538–1542.
- Trivedi H, et al. Effect of variation of blood flow rate on blood pressure during hemodialysis. ASN Annual Meeting, Philadelphia, PA. *J Am Soc Nephrol.* 2005;16:39A.
- Van der Sande FM, et al. Effect of dialysis solution calcium concentration on intradialytic blood pressure course in cardiac-compromised patients. *Am J Kidney Dis.* 1998;32:125–131.
- Van der Zee S, et al. Vasopressin administration facilitates fluid removal during hemodialysis. *Kidney Int.* 2007;71:318–324.
- Wikström B, et al. Kappa-opioid system in uremic pruritus: multicenter, randomized, double-blind, placebo-controlled clinical studies. *J Am Soc Nephrol.* 2005;16:3742–3747.
- Yalcin AU, et al. Effect of sertraline hydrochloride on cardiac autonomic dysfunction in patients with hemodialysis-induced hypotension. *Nephron Physiol.* 2003;93:P21–P28.

A dialysis facility may use dialyzers for the same patient for multiple treatments. Dialyzer reuse can be a safe and effective practice. As the cost of high-flux, biocompatible dialyzers has come down, prevalence of reuse in the United States has fallen from 78% of facilities in the mid-1990s to about 50% of facilities (47% of patients) in 2013 (Upadhyay, 2007; Neumann, 2013). Only hollow-fiber dialyzers, labeled by the manufacturer for multiple use, may be reprocessed.

- I. **REPROCESSING TECHNIQUE.** To use a dialyzer multiple times, the dialysis unit must meticulously follow the standards set out by the Association for the Advancement of Medical Instrumentation (ANSI/AAMI RD47:2002/A1:2003). These AAMI standards are incorporated in the Medicare ESRD Facility Conditions for Coverage (ESRD Interpretive Guidance, V304–V368). Some of the text and language in the Medicare conditions differs from the text and language in the AAMI document; however, the Centers for Medicare and Medicaid Services (CMS) holds the facility accountable for the text and language in the AAMI document.

While it is possible to accomplish safe and effective reprocessing using a manual technique, the preponderance of reprocessing is done with automated equipment. Several types of automated machines are now manufactured. Some machines provide the ability to process multiple dialyzers simultaneously. With **automated methods**, the cleansing cycles are reproducible and a variety of quality control tests measuring total cell volume (TCV) (fiber bundle volume + volume in the headers), ultrafiltration coefficient, and the ability of the reused dialyzer to hold a pressure applied to the blood compartment are built in. Automated equipment also facilitates printing of dialyzer labels and computerized analysis of records and testing results.

Any medical director wishing to use a **manual system** must validate each step of the process and design appropriate quality control steps and audits to assure adherence and consistency. On the other hand, any automated equipment used must have a U.S. Food and Drug Administration (FDA) 510(k) clearance. (A 510[k] is a premarket submission made to FDA to demonstrate that the device to be marketed is at least as safe and effective as; that is, substantially equivalent to, a legally marketed device that is not subject to premarket approval.) It is incumbent on the medical director using automated equipment to follow the manufacturer's directions for use.

Reprocessing can be divided into three phases: pre–first-use, the dialysis treatment, and postdialysis.

- A. **Pre–first-use.** The dialyzer is recorded into inventory, assigned to a patient (at which time it is indelibly labeled with patient name, noting whether there are any similarly named patients in the dialysis unit). Prior to initial use, the dialyzer is preprocessed to measure the baseline TCV. During preprocessing, the dialyzer is rinsed, pressure-tested, and filled with a germicide.
- B. **The dialysis treatment.** Prior to allowing a reprocessed dialyzer to be used on a patient, the patient care provider (PCP) should inspect the dialyzer to be sure that it is not discolored, leaking, or showing significant clotting of fibers in the header. The facility medical director should establish a definition of “significant clotting” to guide staff. Peracetic acid has no vapor pressure and depends on direct contact to be effective; if peracetic acid was used to disinfect the dialyzer, the PCP must assure that a sufficient volume of disinfectant fluid was present in the dialyzer to assure direct contact. This is done by examining the air-fluid level in the headers when the dialyzer is held horizontally: both headers should be at least two-thirds full. The PCP must confirm that there is germicide in the dialyzer, that the contact time of the dialyzer with the germicide exceeds the minimum number of hours required for that particular germicide, and that the dialyzer has passed all the required performance tests. The presence of germicide is confirmed by using a test strip of appropriate sensitivity. The PCP then primes the dialyzer with normal saline and starts a recirculating rinse, with minimal ultrafiltration, at a blood compartment recirculating flow rate of at least 200 mL/min, while flowing dialysate through the dialysate compartment at 500 mL/min or more. This rinse is continued for 15–30 minutes. It is important to avoid introducing air into the arterial circuit during this rinsing process, as any air trapped in the fibers or dialysate compartment may reduce the effectiveness of germicide removal. The dialyzer should be rotated at intervals during flushing to release trapped air in the dialysate compartment. After the rinse, the PCP must assure that the dialyzer, extracorporeal circuit, and saline bag are free of residual germicide by use of a test strip of appropriate sensitivity.

After rinsing has been completed, if the start of the treatment is delayed for some reason, before putting the patient on dialysis, the PCP should retest for a “rebound” of germicide caused by either the dialysate or saline flow being interrupted while the dialyzer is in standby. The medical director should set guidelines for the dialysis unit, specifying how long a dialyzer, once it has been set up for a patient, can sit on the machine before it is deemed unsuitable for use without a repeat cycle of reprocessing.

Before the PCP starts the treatment, two PCPs should perform a “time-out,” during which they follow a checklist assuring that critical elements of the dialysis prescription are correctly set for this patient’s treatment. For reuse, the critical elements are that this dialyzer is for this patient, that it is the correct model dialyzer, that it had the appropriate contact time with the germicide, that it is now free of germicide, and that information on the reprocessing label confirms that the dialyzer is safe to use. If possible, it is desirable that the patient participate in this step. Both PCPs should sign off on the safety checklist.

- C. **Postdialysis.** At the end of a treatment, the PCP returns the blood in the dialyzer to the patient in such a way as to minimize the amount of blood left in the dialyzer. The PCP or the reuse staff transports the dialyzer to the reprocessing area, making sure that the dialyzer ports are

capped and that there is no cross-contamination with other dialyzers that are being transported at the same time. The dialyzer is then rinsed, cleaned, tested, disinfected, inspected, labeled, and stored until the next use. The medical director must validate any practices in the reuse process that are not explicitly described in the AAMI standards or the dialyzer manufacturer's "directions for use."

1. **Rinsing and reverse ultrafiltration postdialysis.** To maintain the patency of fibers and to minimize clotting after dialysis, blood can be returned with heparinized saline. Once the patient has been detached from the extracorporeal circuit, the PCP can add positive dialysate pressure to force residual blood from the fibers. If, after use, a dialyzer cannot be promptly reprocessed, the dialyzer should be refrigerated in a temperature-monitored container (avoiding freezing) within 2 hours (AAMI RD47:2002). Facility practice as approved by the medical director should set limits for how long the dialyzers can be refrigerated before being reprocessed or discarded. Typically, this maximum time varies between 36 and 48 hours from the end of treatment. The staff may not refrigerate a dialyzer that has been exposed to rinsing with nonsterile RO (reverse osmosis) water; while AAMI standards do not require water used in rinsing to be sterile, once the blood compartment has been exposed to other than sterile fluids, the dialyzer must be promptly reprocessed.
2. **Cleaning.** Typically, this is accomplished in two steps. The first involves an initial rinsing of the dialyzer and cleaning the headers with RO water. The second is to put the dialyzer on a machine (or through a manual process) that further rinses and cleans the fibers using one of a number of chemical cleaning agents.
 - a. **Water.** Water used for rinsing and reprocessing must, at a minimum, meet AAMI standards. The current Medicare "conditions for coverage" (ESRD Interpretive Guidance, V176–V278, 2008; ANSI/AAMI RD52: 2004) requires adherence to the AAMI standards current in 2008 when the conditions were published. In 2008, those standards specified a bacteria upper limit of <200 cfu/mL (colony forming units/mL) and an endotoxin upper limit of <2 eu/mL (endotoxin units/mL). The action levels were <50 cfu/mL and <1 eu/mL, respectively. These are the standards that Medicare surveyors will enforce. However, in 2011, AAMI reduced the maximum allowable bacteria count in water to <100 cfu/mL and endotoxin to <0.25 eu/mL with action levels of <50 cfu/mL and <0.125 eu/mL, respectively. The new stricter limits also call for use of more rigorous microbiologic techniques and longer incubation times to assess the bacterial colony forming unit count. As of 2014, CMS has not revised the "conditions for coverage" to include these revised, more stringent, standards. The medical director approved policy and procedure should state explicitly what is meant by the phrase "AAMI standard" water. At a minimum, water used must meet the standards in the Medicare "conditions of coverage."
 - b. **Rinsing and reverse ultrafiltration.** While this process may have been started with saline (heparinized or otherwise) while the dialyzer was still on the dialysis machine (see Section I.C.1), the most common practice is to put the dialyzer on a manifold that flushes AAMI standard water (see above discussion) through the blood and

dialysate compartments for 20–30 minutes. During flushing, a positive pressure gradient from the dialysate to the blood compartments is maintained to help flush clots and plasma detritus from the blood circuit. The pressures in this manifold must not exceed those specified by the manufacturer’s directions for use to avoid rupturing or collapsing the hollow fibers.

During this cleaning step, staff inspect and clean the headers to remove lipids and clots. For dialyzers that do not have removable header caps, there are assist devices that use RO water to flush the headers. If the header caps are removable, they and the associated “O” rings can be removed, allowing a direct rinse of the exposed ends of the fiber bundle and potting compound.

Any procedure that invades the blood compartment risks cross-contamination. AAMI standard water, even as defined in the 2011 revision, is not sterile. If the procedure uses assist devices, it must specify that these devices be used on only one dialyzer before they are cleaned and soaked in an appropriate germicide. If the practice allows the removal of the header caps, they and their “O” rings must be exposed to a disinfectant (bleach or peracetic acid) before being replaced on the dialyzer. Staff must take care not to damage the end of the exposed fiber bundle. Failure to adhere to correct practices in the step of dialyzer header cleaning has frequently been the root cause of outbreaks of bloodstream infections and pyrogen reactions.

The current generation of reprocessing equipment is not able to effectively remove large amounts of clot and detritus from the fiber bundle or header. It is necessary to subject the dialyzer to the precleaning steps described earlier. One novel machine for dialyzer reprocessing (ClearFlux™, from the Novaflux corporation, Princeton, NJ) does not require a precleaning with nonsterile fluids before reprocessing. With this particular machine, the first step in reprocessing is to run a mixture of compressed air and a proprietary cleaning agent through the dialyzer; this mixture effectively removes clots from the dialyzer headers (Wolff, 2005).

- c. **Bleach.** Sodium hypochlorite (bleach), diluted to 0.06% or less, dissolves proteinaceous deposits that may occlude dialyzer hollow fibers. The bleach used should be free of dyes or scents and be listed by the EPA as suitable for cleaning and disinfection.
 - d. **Peracetic acid.** Peracetic acid (mixture of acetic acid and hydrogen peroxide) is the most commonly used cleaning agent (HICPAC, 2008). Peracetic acid is available in proprietary and generic versions. Peracetic acid may not completely remove proteins deposited on the dialyzer membrane.
3. **Tests of dialyzer performance.** These check the integrity of the membrane, its clearance (TCV), and its ultrafiltration properties. The tests may be done manually or using automated techniques.
- a. **Pressure test for leaks.** A blood path integrity test works by generating a pressure gradient across the membrane and observing for a pressure fall in either the blood or the dialysate compartment. The gradient may be produced by instilling

pressurized air or nitrogen into the blood side of the dialyzer or by producing a vacuum in the dialysate side. Only minimal amounts of air should be observed to leak through an intact wetted membrane; damaged fibers usually rupture when a transmembrane pressure gradient is applied. Leak tests also screen for defects in the dialyzer O-rings, potting compound, and end-caps.

- b. **Blood compartment volume.** This test indirectly measures changes in membrane clearance for small molecules such as urea. The blood compartment volume (TCV) is measured by purging the filled blood compartment (header volume and fiber volume) with air and measuring the volume of obtained fluid. Every dialyzer destined for reprocessing should be processed before its initial use in order to measure a baseline TCV for that particular dialyzer. The change in TCV from baseline is then tracked by remeasuring TCV after each reuse. A reduction in TCV of 20% corresponds to a 10% reduction in urea clearance, the maximum decrease acceptable for continued use. In a given patient, repeated failure to reach a target number of reuses because of TCV test failures suggests excessive clot formation during dialysis and should prompt a review of the heparin prescription.
- c. **Water permeability (in vitro K_{UF}).** The dialyzer ultrafiltration coefficient (K_{UF} ; described in Chapter 3) measures water permeability but is also an indirect measure of membrane mass transfer properties for larger molecular weight substances. The in vitro K_{UF} can be measured by determining the volume of water passing through the membrane at a given pressure and temperature. Changes in K_{UF} do not affect fluid removal during dialysis, as most dialysis being done today uses machines with automated ultrafiltration control that will compensate for even moderate decreases in water permeability with appropriate adjustments in transmembrane pressure. However, a decrease in K_{UF} usually is accompanied by a reduction in β_2 -microglobulin clearance.
- d. **Clinical confirmation.** Online, conductivity determined sodium or ionic clearance, which is comparable to urea clearance, or online measurement of other proxies of urea clearance are other acceptable methods of monitoring dialyzer performance (AAMI RD47:2002). Such online clearance measurements are done during the dialysis treatment and require a process of record keeping to track and compare them with reuse numbers or TCV.

The facility QAPI (QAPI = Quality Assurance / Performance Improvement) team can correlate the laboratory-measured Kt/V with the reuse number across all patients in the dialysis unit, or it can investigate failures to deliver adequate Kt/V or URR as a function of reuse history in a given patient. The QAPI team must show that reuse is not adversely affecting dialysis efficiency.

4. **Disinfection/sterilization.** Once cleaned, the dialyzer must undergo a chemical (germicide) or physical (heat) process that renders all living organisms inactive. High-level disinfection differs from sterilization in that the former may not destroy spores. High-level disinfection is all that current standards require. Sterilization as defined legally is not easily accomplished in a dialysis facility.

- a. **Germicides.** After a dialyzer has been cleaned and tested, germicides are instilled in both blood and dialysate compartments for an appropriate contact duration (see Section I.C.7). Peracetic acid is the most common germicide used. The use of formaldehyde or glutaraldehyde has essentially disappeared, probably because there are no automated methods for dialyzer reprocessing using formaldehyde or glutaraldehyde, and because manual methods for aldehyde chemical reuse are burdensome, having to meet U.S. Occupational Safety and Health Administration (OSHA) standards for safe handling, attention to exposure limits, and surveillance and respiratory testing for exposed staff.
 - b. **Documenting the presence of germicide.** The presence of germicide must be ensured through procedural controls and should be verified both at the completion of reprocessing and prior to use (see Section I.B). The presence of peracetic acid is confirmed using test strips. If formaldehyde is used, FD&C (U.S. Food, Drugs & Cosmetic Act) blue dye can be put in the concentrated (37%) formalin to give the dialyzer a light blue color once the formaldehyde is diluted. In manual reprocessing systems, each dialyzer must be checked for the presence of germicide. In automated systems, only a sample needs to be tested each day.
 - c. **Heat sterilization.** Heated 1.5% citric acid at 95°C (Levin, 1995) or the original method of using heated water at 105°C (Kaufman, 1992) are nonnoxious chemical alternatives to disinfection. Laboratory studies have shown that with these methods of disinfection, spores are destroyed. Methods of disinfection using heat with or without citric acid are efficacious; however, they are somewhat cumbersome, as they are not available in automated form. Also, heat disinfection affects the durability of many types of dialyzers being reprocessed. Medical directors electing to use heat disinfection must demonstrate its effectiveness in their dialysis facility and need to design and implement appropriate quality control and auditing procedures.
5. **Final inspection.** A thorough visual inspection of the dialyzer should be made by the reprocessing staff member at the end of a reprocessing procedure, and then again by the PCP when setting up the reprocessed dialyzer prior to the dialysis treatment. If the dialyzer does not meet the visual inspection standards (described in Section I.B), it should be sent for another cycle of reprocessing (e.g., if the germicide volume is not adequate), or the dialyzer should be discarded if it is damaged or unaesthetic in appearance.
 6. **Labeling.** After the staff is satisfied that the dialyzer has passed performance testing and inspection, they should affix a label to the dialyzer in a way that does not obscure the patient's name or the manufacturer label. At a minimum, the label should indicate the patient's name, a warning regarding the existence of a similar name in the unit, if applicable, the number of reuses, the baseline and current TCV, the time and date the dialyzer was reprocessed, and whether the dialyzer passed performance testing. The same information and additional detail as indicated should be recorded in the reuse master file. If the dialyzer failed any tests and was discarded, this should be recorded. Such information provides data that the QAPI team can use to assess the quality and

consistency of the reuse program.

7. **Storage.** Once inspected and labeled, the dialyzer must be stored in a manner that allows continued surveillance and management of multiple dialyzers assigned to the same patient. The temperature of the storage room is important, as the recommended germicide contact time depends on storage temperature. Peracetic acid has a shelf life of 14–21 days, and might be shorter in dialyzers with significant residual blood, as the interaction of residual blood with the peracetic acid reduces its concentration. For this reason, peracetic acid sterilized dialyzers should be re-disinfected every 14 days. It is not certain how long a dialyzer (even with periodic re-disinfection) can safely be stored before it should be discarded. The medical director should specify the time limit for re-disinfection and disposal of stored dialyzers.

II. CLINICAL ISSUES. When reprocessing is performed in accordance with accepted standards and practices, the risks of the procedure are manageable. Performing in accordance with accepted standards is not without challenges. Reprocessing staff may be the least supervised staff in the dialysis facility. In some facilities, reprocessing is done off-site beyond the supervision of the facility staff. Results of Medicare surveys show numerous citations being issued related to failure to comply with the conditions and standards for dialysis reprocessing (Port, 1995). The decision to reprocess dialyzers is a risk versus benefit calculation that the medical director and governing body need to make (Upadhyay, 2007).

A. Clinical benefits, the argument for

1. **Cost.** This issue is discussed later in the chapter in Section IV.B.
2. **First-use reactions and complement activation.** Dialyzer reactions characterized by restlessness, chest pain, coughing, dyspnea, hypoxemia, and hypotension appeared to be less frequent when reprocessed dialyzers are used, although some patients demonstrate sensitivity to the membrane even with multiply reprocessed dialyzers. One source of these reactions is a membrane–blood interaction (bio-incompatibility) that results in the complement-mediated (alternative pathway) sequestration of leucocytes in the pulmonary circulation. During the use of a dialyzer, the dialyzer membrane becomes coated with proteinaceous material. Many reprocessing methods, especially those using peracetic acid, do not remove this protein coat during the cleaning phase, rendering the membrane more biocompatible during subsequent use. Reprocessing a dialyzer with bleach has the effect of stripping off this proteinaceous coat, potentially resulting in a less biocompatible dialyzer. Other reactions may be caused by a true IgE-mediated anaphylactoid reaction to residual ethylene oxide used to sterilize the dialyzer, and still other reactions may be due to uncharacterized components leached from the dialyzer or blood lines. In the course of preprocessing and reprocessing, the dialyzer, ethylene oxide, and other chemicals used during dialyzer manufacture are removed from the dialyzer, reducing their ability to leach into the patient during dialysis. However, the abandonment of unsubstituted cellulosic membranes, ethylene oxide sterilization, and the development of more biocompatible synthetic membranes has markedly reduced the incidence of these reactions with single use, reducing the advantages of reprocessing in this area.

3. **Biohazardous waste.** Most dialysis providers have to pay a price for the disposal of biohazardous waste that is calculated on a per pound basis. Dialyzer reprocessing reduces the number of pounds of dialyzers and packaging included in that waste. This not only saves the dialysis provider money but also reduces the waste burden to the environment. On the other hand, there are environmental issues with reprocessing as well: energy as well as water are used in reprocessing, and the chemicals used to clean and disinfect the dialyzers are put into the waste stream and need to be dealt with by sewage treatment facilities. Some waste treatment authorities do not allow users to discharge formaldehyde into the waste water. The gloves, strips, masks, and gowns used in the reprocessing procedure also contribute to the waste burden (Hoenich, 2005; Upadhyay 2007).

B. **Clinical concerns, the argument against**

1. **Formaldehyde.** When formaldehyde was in widespread use, providers reported patients who developed anti-N antibodies (Vanholder, 1988) and acute “formaldehyde reactions” characterized by burning at the needle site and itching during dialysis in the access arm.
2. **Morbidity and mortality.** This is the most contested aspect of dialyzer reuse. Most of the reuse outcomes studies were done during the era of cellulosic dialyzers at the beginning of the introduction of the more expensive more biocompatible synthetic membranes. To date, the published studies have been observational with all of their associated potential for bias and confounding by indication. These earlier studies are not likely to be generalizable to current reprocessing practices. There have been no large prospective, randomized controlled trials of dialyzer reuse versus single use. In a systematic review (Galvao, 2012), the authors concluded that there was no published evidence supporting an adverse effect on mortality of multiple use compared with single use. A recent study that included the large cohort of patients dialyzed at DaVita (Bond, 2011) showed no adverse effect of multiple use on mortality. A smaller study that followed a sample of patients in 23 Fresenius units who were converted from peracetic acid reprocessing to single use (Lacson, 2011) did show a decreased relative risk of mortality and a reduction in inflammatory markers after conversion to single use. Neither of these two studies was included in the systematic review of Galvao (2012).

In some early studies, reuse with formaldehyde was associated with better outcomes than reuse with peracetic acid (Held, 1994). Formaldehyde, with its vapor pressure, might be considered to provide a larger margin of safety than peracetic acid, which depends on direct contact for disinfection. The FDA response to the initial studies was to require significant improvement of the directions for use of peracetic acid and more stringent quality control. Later observational trials in the Medicare database failed to show a difference in outcomes between formaldehyde and peracetic acid (Collins, 2004). This suggests that facilities using peracetic acid may have become better at reprocessing over time.

3. **Potential bacterial/pyrogen contamination.** Bacteremia and pyrogen reactions can result from improperly processed dialyzers. Clusters of pyrogen reactions occur slightly more

often in centers that reuse dialyzers. Clusters of bacteremia caused by gram-negative water-borne bacteria (*Stenotrophomonas maltophilia*, *Burkholderia cepacia*, or *Ralstonia pickettii*) are rarely if ever reported in single-use dialysis facilities, but outbreaks have been reported in facilities using dialyzer reprocessing. The true incidence of these outbreaks is not known, as they are unlikely to be reported unless of such a magnitude or persistence that state or federal health authorities are consulted. The source of such problems is generally the water used to rinse and clean the dialyzers and to prepare the germicides used for disinfection. Scrupulous attention to water treatment (disinfection, loop path, and flow velocity) is required (Hoenich, 2003). Any step in the reprocessing procedure that introduces a foreign object and/or unsterile water into the blood compartment is a potential source of cross-contamination. Peracetic acid is less effective in dialyzers with substantial residual blood and protein. Bacteria sequestered in clotted fibers may not be exposed to the sterilant but can be dislodged during the dialysis treatment.

4. **Potential of anaphylactoid reactions with use of peracetic acid/hydrogen peroxide/acetic acid reuse agents and angiotensin-converting enzyme (ACE) inhibitors.** An outbreak of anaphylactoid reactions to reused dialyzers occurred in patients dialyzed with cuprammonium cellulose, cellulose acetate, and polysulfone dialyzers reprocessed with peracetic acid. Most were being treated with ACE inhibitors (Pegues, 1992). Reuse of dialyzers with oxidizing agents, such as peracetic acid, can produce a strong negative charge on the protein-coated membrane and thereby activate factor XII, kininogen, kallikrein, and, subsequently, bradykinin. ACE inhibitor–induced inhibition of bradykinin degradation may potentiate the reaction. Similar reactions have been described with the use of polyacrylonitrile membrane and attributed to membrane-induced bradykinin generation. In another small case series, reactions in patients taking ACE inhibitors began when bleach was added to the reuse procedure and ceased when use of bleach was discontinued (Schmitter and Sweet, 1998). For patients with unexplained adverse reactions early in the treatment, it is appropriate to review the medication list for ACE inhibitors, irrespective of reprocessing technique or germicide.
5. **Bleach cleaning and dialyzer reactions.** During normal dialysis, the dialyzer membrane becomes coated with a proteinaceous material, which often has the effect of making the membrane more biocompatible. Reprocessing a dialyzer with bleach has the effect of stripping off this proteinaceous coat, potentially resulting in a less biocompatible dialyzer.
6. **Potential transmission of infectious agents.** Of concern are hepatitis B (HBV), hepatitis C virus (HCV), and human immunodeficiency virus (HIV). The current Medicare “conditions of coverage” require exclusion of patients with HBV from reuse (V301) and instruct that they be dialyzed in a separate isolation room (V128). According to current Centers for Disease Control and Prevention (CDC) recommendations, patients with HIV may continue on a reuse program. HIV patients do not require dialysis in an isolation room. The medical director may wish to exclude HIV patients from reuse to limit staff exposure to HIV-infected blood. Currently, CDC neither requires isolation nor proscribes reuse in patients with HCV. For HIV and HCV, CDC considers

universal precautions adequate to protect staff and other patients.

7. **Potential for decreased dialyzer performance**

a. **Urea clearance.** A reused hollow-fiber dialyzer ultimately becomes less efficient as a portion of its capillaries become plugged with protein or clot from previous uses. However, as long as the fiber bundle volume is at least 80% of the baseline value, urea clearance remains clinically acceptable. The HEMO study confirmed these data and found in a large number of patients using dialyzers reprocessed by different methods, that the decrease in urea clearances (Cheung, 1999) was, at most, modest. The HEMO study found that, independent of the reuse method, urea clearance decreased 1.4%–2.9% over 20 uses.

1. **Heparin dosing.** The reusability of dialyzers will deteriorate quickly unless adequate heparin anticoagulation is given. One group has reported increased numbers of reuses with individually targeted heparin dosing (Ouseph, 2000). Appropriate heparin dosing is no less important for single-use programs.

2. **Bicarbonate dialysis solution containing citric acid.** Bicarbonate dialysate containing a small amount of citrate in place of acetate has been reported to result in increased urea clearance in a reuse setting (Ahmad, 2005; Sands, 2012). This observation may be related to calcium chelation by citrate coming in from the dialysate at the membrane boundary layer, with perhaps reduced activation of clotting factors and platelets. This anticoagulant effect is also of potential benefit in single-use programs.

b. **β_2 -microglobulin clearance.** Protein deposits adsorbed on the membrane or convectively transported to the membrane surface and not removed by the reuse process may reduce the ultrafiltration rate and larger molecule clearance. High-flux dialyzer performance with respect to β_2 -microglobulin clearance may be altered dramatically by reuse, depending on the type of membrane and type of reuse procedure (Cheung, 1999). Of most concern is the rapid falloff in β_2 -microglobulin clearance when high-flux cellulose dialyzers are reused with peracetic acid/hydrogen peroxide/acetic acid without a bleach cycle. This loss of clearance with peracetic acid reuse does not occur with the use of the Novaflux reprocessing machine, where the use of the air-fluid two-phase cleaning system appears to maintain both water permeability and clearance of higher-molecular-weight molecules.

8. **Albumin loss.** Some dialyzers exposed to bleach during reuse procedures may undergo an increase in permeability to albumin that correlates with the number of reuses. This is most pronounced for dialyzers with very high water permeability.

III. OTHER ISSUES

A. **Regulatory aspects**

1. **US federal regulations.** There are guidelines for dialyzer reuse (NKF, 2007) that are useful for medical directors to review and consider in developing and/or managing a dialyzer reuse program. The Medicare “conditions for coverage” that incorporate the AAMI

standards (V304–V368, RD47:2002) are the controlling rules. The medical director is responsible for the decision to have a reprocessing program (V311). That decision should be reflected in the minutes of the governing body. The medical director is accountable for the training and competence of the staff performing reuse (V308 ff). The patient's nephrologist must agree to and order reprocessing for his or her patient (V311). The medical director must suspend reuse when there is a cluster of adverse patient events that could be attributed to the reuse program (V382). The reuse program should be the subject of ongoing review and monitoring by the facility QAPI team (V594, V626).

2. **Manufacturer single-use recommendation.** Because of the previous widespread practice of reusing dialyzers labeled for single use only, the FDA developed guidelines that allow manufactures to label their dialyzers for multiple use, recommend an appropriate reuse method, and provide performance data of dialyzers over 15 reuses (FDA, 1995). Dialyzer manufacturers may choose to continue to label their dialyzers for single use only.
 3. **Reuse of other dialysis disposables.** Medicare conditions do not allow reuse of transducer protectors. Guidelines for the reuse of blood tubing have been published (Reuse of hemodialyzers, AAMI, 2002). However, blood tubing reuse is permitted only when the manufacturer has developed a specific protocol that has been accepted by the FDA. Currently, no such product is available.
 4. **Informed consent.** There is no rule requiring informed consent as a condition for reprocessing dialyzers. The Medicare conditions require that patients and their family (caregivers) be fully informed about all aspects of their care. For reuse, the facility should provide written information about the risks and benefits of reprocessing in language appropriate for the patient. The information should describe the rationale for the program. The patient should be invited to participate as fully as he or she is interested in assuring that the dialyzer is appropriately identified and safe for reuse.
- B. **Cost.** The strongest argument for multiple-use dialyzers is that cost savings enable the use of dialyzers that have higher mass transfer coefficients and that are more biocompatible. This argument is less compelling as the cost of efficient, high-flux dialyzers has been reduced. Additionally, since the United States is the major market for dialyzers labeled for multiple use, manufacturers may choose not to go through the expense and requirements of certifying the dialyzer for multiple use just to satisfy the US market. This has the paradoxical effect of reducing the choices of dialyzers available to patients. When providers consider all the costs of reprocessing dialyzers, the difference may be small. While the initial cost of the multiple-use dialyzer is more than the equivalent dialyzer labeled for single use, the average cost of the multiple-use dialyzer falls with each reuse. The true cost of the multiple-use dialyzer cannot fall below the cost of reprocessing, no matter how many times it is used. The cost of reprocessing includes the wages and benefits for the reprocessing staff, the cost of training and documenting and maintaining competence. Providers must consider the capital cost and depreciation cost of the reprocessing equipment. Additionally, each reprocessing cycle consumes electricity, water, cleaning chemicals, and germicides. Costs of test strips, routine cultures, and Limulus amoebocyte lysate (LAL) tests

for reuse water must also be factored in, as must the cost of the additional QAPI procedures necessary to maintain a safe and effective reuse program.

- C. **Quality assurance and performance improvement.** The reuse program must be part of the QAPI program under the accountability of the medical director (V594, V626). QAPI records must track staff training, continued staff competence, audits, validation, microbiology, average number of reuse, reasons for failure, adverse events, patient complaints, and the root cause analysis of any event requiring the suspension of reuse. The requirements are detailed in the AAMI standards. The facility must maintain a history of the dialyzer from preprocessing to disposal.
- D. **Training.** A comprehensive training course should be established for all personnel performing reprocessing. Competence should be verified for each item on the curriculum. The medical director is accountable for the training program and competent performance of the staff (V308 ff).
- E. **Personnel safety and physical plant considerations.** The use of protective eyewear and clothing is stressed, as is proper handling of germicide spills. Where germicides are used, the workspace should be designed with air turnover at least equivalent to the clinical area with forced inward air and additional ceiling exhaust ducts, as well as ducts located lower toward the floor if formaldehyde is used. Exposure to germicides is regulated by OSHA. Current (1990) maximum allowable time-weighted average (TWA) exposure for formaldehyde is 1 ppm and for short-term exposure is 3 ppm. Maximum exposure limits for hydrogen peroxide is 1 ppm TWA and for glutaraldehyde is 0.2 ppm. There are no current OSHA exposure limits for peracetic acid.

References and Suggested Readings

- Ahmad S, et al. Increased dialyzer reuse with citrate dialysate. *Hemodial Int*. 2005;9:264–267.
- Association for the Advancement of Medical Instrumentation. *Reuse of Hemodialyzers*. Washington, DC: American National Standards Institute; 2002. ANSI/AAMI RD47.
- Association for the Advancement of Medical Instrumentation. *Dialysate for Hemodialysis*. Arlington, VA: Association for the Advancement of Medical Instrumentation; 2004. ANSI/AAMI RD52.
- Association for the Advancement of Medical Instrumentation. *AAMI Standards—Dialysis*. Arlington, VA: Association for the Advancement of Medical Instrumentation; 2011.
- Bond TC, et al. Dialyzer reuse with peracetic acid does not impact patient mortality. *Clin J Am Soc Nephrol*. 2011;6:1368–1374.
- Charoenpanich R, et al. Effect of first and subsequent use of hemodialyzers on patient well being. *Artif Organs*. 1987;11:123.
- Cheung A, et al. Effects of hemodialyzer use on clearances of urea and beta-2 microglobulin. The Hemodialysis (HEMO) Study Group. *J Am Soc Nephrol*. 1999;10:117–127.
- Collins AJ, et al. Dialyzer reuse-associated mortality and hospitalization risk in incident Medicare haemodialysis patients, 1998–1999. *Nephrol Dial Transplant*. 2004;19:1245–1251.
- ESRD interpretive guidance. 2008. <http://www.cms.gov/Medicare/Provider-Enrollment-and-Certification/GuidanceforLawsAndRegulations/Downloads/esrdpgmguidance.pdf>.
- Fan Q, et al. Reuse-associated mortality in incident hemodialysis patients in the United States, 2000–

2001. *Am J Kidney Dis.* 2005;46:661–668.

Food and Drug Administration (FDA). Guidance for hemodialyzer reuse labeling. U.S. Food and Drug Administration, Rockville, MD. October 6, 1995. <http://www.fda.gov/downloads/MedicalDevices/DeviceRegulationandGuidance/GuidanceDocuments/UCR007107.pdf>. Last accessed 08/04/2014.

Galvao F, et al. Dialyzer reuse and mortality risk in patients with end-stage renal disease: a systematic review. *Am J Nephrol.* 2012;35:249–258.

Gotch FA, et al. Effects of reuse with peracetic acid, heat and bleach on polysulfone dialyzers [Abstract]. *J Am Soc Nephrol.* 1994;5:415.

Hakim RM, Friedrich RA, Lowrie EG. Formaldehyde kinetics in reused dialyzers. *Kidney Int.* 1985;28:936.

Held PJ, et al. Analysis of the association of dialyzer reuse practices and patient outcomes. *Am J Kidney Dis.* 1994;23:692–708.

HICPAC. Guideline for disinfection and sterilization in healthcare facilities. 2008. http://www.cdc.gov/hicpac/disinfection_sterilization/13_06peraceticacidsterilization.html. Accessed March 3, 2014.

Hoenic NA, Levin R. The implications of water quality in hemodialysis. *Semin Dial.* 2003;16:492–497.

Hoenic NA, Levin R, Pearce C. Clinical waste generation from renal units: implications and solutions. *Semin Dial.* 2005;18:396–400.

Kaplan AA, et al. Dialysate protein losses with bleach processed polysulfone dialyzers. *Kidney Int.* 1995;47:573–578.

Kaufman AM, et al. Clinical experience with heat sterilization for reprocessing dialyzers. *ASAIO J.* 1992;38:M338–M340.

Kliger AS. Patient safety in the dialysis facility. *Blood Purif.* 2006;24:19–21.

Lacson E, et al. Abandoning peracetic acid-based dialyzer reuse is associated with improved survival. *Clin J Am Soc Nephrol.* 2011;6:297–302.

Levin NW, et al. The use of heated citric acid for dialyzer reprocessing. *J Am Soc Nephrol.* 1995;6:1578–1585.

Lowrie EG, et al. Reprocessing dialyzers for multiple uses; recent analysis of death risks for patients. *Nephrol Dial Transplant.* 2004;19: 2823–2830.

National Kidney Foundation task force on the reuse of dialyzers. *Am J Kidney Dis.* 2007;30:859–871.

Neumann ME. Moderate growth for dialysis providers. *Nephrol News and Issues.* 2013;27:18.

Ouseph R, et al. Improved dialyzer reuse after use of a population pharmacodynamic model to determine heparin doses. *Am J Kidney Dis.* 2000;35:89–94.

Pegues DA, et al. Anaphylactoid reactions associated with reuse of hollow fiber hemodialyzers and ACE inhibitors. *Kidney Int.* 1992;42:1232–1237.

Pizziconi VB. Performance and integrity testing in reprocessed dialyzers: a QC update. In: AAMI, ed. *AAMI Standards and Recommended Practices.* Vol 3. Dialysis. Arlington, VA: AAMI; 1990:176.

Port FK. Clinical outcomes in patients with reprocessed dialyzers. Paper presented at: National Kidney Foundation Symposium on Dialyzer Reprocessing; November 3, 1995; San Diego, CA.

Rahmati MA, et al. On-line clearance: a useful tool for monitoring the effectiveness of the reuse

procedure. *ASAIO J.* 2003;49:543–546.

Rancourt M, Senger K, DeOreo P. Cellulosic membrane induced leucopenia after reprocessing with sodium hypochlorite. *Trans Am Soc Artif Intern Organs.* 1984;30:49–51.

Sands JJ, et al. Effects of citrate acid concentrate (Citrasate[®]) on heparin requirements and hemodialysis adequacy: a multicenter, prospective noninferiority trial. *Blood Purif.* 2012;33:199–204.

Schmitter L, Sweet S. Anaphylactic reactions with the additions of hypochlorite to reuse in patients maintained on reprocessed polysulfone hemodialyzers and ACE inhibitors. Paper presented at: Annual Meeting of the American Society for Artificial Internal Organs; April 1998; New Orleans.

Vanholder R, et al. Development of anti-N-like antibodies during formaldehyde reuse in spite of adequate predialysis rinsing. *Am J Kidney Dis.* 1988;11:477–480.

Twardowski ZJ. Dialyzer reuse—part I: historical perspective. *Semin Dial.* 2006;19:41–53.

Twardowski ZJ. Dialyzer reuse—part II: advantages and disadvantages. *Semin Dial.* 2006;19:217–226.

Upadhyay A, Sosa MA, Javer BL. Single-use versus reusable dialyzers: the known and unknowns. *Clin J Am Soc Nephrol.* 2007;2:1079–1086.

US Renal Data System. *USRDS Annual Report.* Bethesda, MD: USRDS; 2004.

Verresen L, et al. Bradykinin is a mediator of anaphylactoid reactions during hemodialysis with AN69 membranes. *Kidney Int.* 1994;45:1497–1503.

Wolff, SW. *Effects of Reprocessing on Hemodialysis Membranes* [doctoral thesis in chemical engineering]. Department of Chemical Engineering, Pennsylvania State University College of Engineering; 2005.

Zaoui P, Green W, Hakim M. Hemodialysis with cuprophane membrane modulates interleukin-2 receptor expression. *Kidney Int.* 1991;39:1020.

I. **BLOOD CLOTTING IN THE EXTRACORPOREAL CIRCUIT.** The patient's blood is exposed to intravenous cannulas, tubing, drip chambers, headers, potting compound, and dialysis membranes during the dialysis procedure. These surfaces exhibit a variable degree of thrombogenicity and may initiate clotting of blood, especially in conjunction with exposure of blood to air in drip chambers. The resulting thrombus formation may be significant enough to cause occlusion and malfunction of the extracorporeal circuit. Clot formation in the extracorporeal circuit begins with activation of leukocytes and platelets, leading to surface blebbing and shedding of surface membrane lipid-rich microparticles, which initiate thrombin generation, activation of coagulation cascades, further thrombin formation and fibrin deposition. Factors favoring clotting are listed in Table 14.1.

A. **Assessing coagulation during dialysis**

1. **Visual inspection.** Signs of extracorporeal circuit clotting are listed in Table 14.2. Visualization of the circuit can be best accomplished by rinsing the system with saline solution while temporarily occluding the blood inlet.
2. **Extracorporeal circuit pressures.** Arterial and venous pressure readings may change as a result of clotting in the extracorporeal circuit, depending on the location of thrombus formation. An advantage of using blood lines with a postpump arterial pressure monitor is that the difference between the postpump and venous pressure readings can serve as an indicator of the location of the clotting. An increased pressure difference is seen when the clotting is confined to the dialyzer itself (increased postpump pressure, decreased venous pressure). If the clotting is occurring in or distal to the venous blood chamber, then the postpump and venous pressure readings are increased in tandem. If the clotting is extensive, then the rise in pressure readings will be precipitous. A clotted or malpositioned venous needle also results in increased pressure readings.

TABLE

14.1

Factors Favoring Clotting of the Extracorporeal Circuit

Low blood flow
High hematocrit

High ultrafiltration rate
Dialysis access recirculation
Intradialytic blood and blood product transfusion
Intradialytic lipid infusion
Use of drip chambers (air exposure, foam formation, turbulence)

TABLE

14.2

Signs of Clotting in the Extracorporeal Circuit

Extremely dark blood
Shadows or black streaks in the dialyzer
Foaming with subsequent clot formation in drip chambers and venous trap
Rapid filling of transducer monitors with blood
“Teetering” (blood in the postdialyzer venous line segment that is unable to continue into the venous chamber but falls back into the line segment)
Presence of clots at the inflow dialyzer header

3. **Dialyzer appearance after dialysis.** The presence of a few clotted fibers is not unusual, and the headers often collect small blood clots or whitish deposits (especially in patients with hyperlipidemia). More significant dialyzer clotting should be recorded by the dialysis staff to serve as a clinical parameter for adjustment of anticoagulant dosing. It is useful to classify the amount of clotting on the basis of the visually estimated percentage of clotted fibers in order to standardize documentation (e.g., <10% of fibers clotted, grade 1; <50% clotted, grade 2; >50% clotted, grade 3).
4. **Measurement of residual dialyzer volume.** In units practicing dialyzer reuse, automated or manual methods are used to determine the clotting-associated fiber loss during each treatment. This is done by comparing the predialysis and postdialysis fiber bundle volumes. Dialyzers suitable for reuse characteristically have <1% fiber loss over each of the first 5–10 reuses.

II. USE OF ANTICOAGULANTS DURING DIALYSIS. When no anticoagulant is used, dialyzer clotting rate during a 3- to 4-hour dialysis session is substantial (5–10%), and when this occurs, it results in loss of the dialyzer and blood tubings, plus loss of approximately 100–180 mL of blood (the combined fill volume of the dialyzer and blood line in the extracorporeal circuit). This is an acceptable risk in many patients judged to be at moderate to high risk of anticoagulant-induced bleeding, because bleeding in such patients may often result in catastrophic consequences, and for such patients anticoagulation-free dialysis (described below) can be appropriately used. However, for the great majority of patients, who are judged not to be at a markedly increased bleeding risk, some form of anticoagulation must be employed. In programs reusing dialyzers, proper levels of anticoagulation during dialysis are key to obtaining reasonable reuse numbers.

There is considerable variability among regions of the world, countries, and even dialysis units about what type of anticoagulation is used during intermittent hemodialysis. Despite a

number of promising alternatives, heparin remains the most common anticoagulant used. In the United States, unfractionated heparin is mostly used, whereas in the European Union, low-molecular-weight heparin (LMWH) is the anticoagulant of choice recommended by the European Best Practice Guidelines (2002). A small number of dialysis units anticoagulate the blood circuit using trisodium citrate, and in special circumstances, direct thrombin inhibitors such as argatroban, heparinoids (danaparoid, fondaparinux), prostanoids, and nafamostat maleate may be used as alternative anticoagulants.

III. MEASURING BLOOD CLOTTING DURING DIALYSIS. While it is important to understand the principles of how clotting tests can be used to monitor heparin therapy, in the United States, because of economic constraints, the relatively low risk of bleeding complications from use of heparin during dialysis, and regulatory issues (the requirement for local laboratory certification), heparin therapy is ordinarily prescribed empirically, without monitoring of coagulation. In patients who are at an elevated risk of bleeding, the need to monitor anticoagulation is often circumvented by using heparin-free dialysis.

When clotting studies are done, blood for clotting studies should be drawn from the arterial blood line, proximal to any heparin infusion site, to reflect the clotting status of the patient rather than that of the extracorporeal circuit. It is very difficult to obtain baseline clotting studies from a venous catheter that has been locked with heparin, because of problems of residual heparin in the catheter, and this step is rarely attempted (Hemmelder, 2003).

A. Clotting tests used to monitor heparin therapy

1. **Activated partial thromboplastin time (APTT).** This is for unfractionated heparin monitoring only. This is the most commonly used test in a hospital setting. APTT results vary with individual assays, so many centers report a ratio compared to control (APPT_r). Heparin resistance states can be falsely suggested owing to elevated levels of factor VIII. Baseline levels may be prolonged because of lupus anticoagulant (Olson, 1998).
2. **Whole-blood partial thromboplastin time (WBPTT).** This is similar to above, but is a bedside test. The WBPTT test accelerates the clotting process by addition of 0.2 mL of actin FS reagent (Thrombofax) to 0.4 mL of blood. The mixture is set in a heating block at 37°C for 30 seconds and then tilted every 5 seconds until a clot forms. The prolongation of the WBPTT is linearly related to the blood heparin concentration (in the range applicable to dialysis). It should not be used to monitor LMWH therapy.
3. **Activated clotting time (ACT).** The ACT test is similar to the WBPTT test but uses siliceous earth to accelerate the clotting process. ACT is less reproducible than WBPTT, especially at low blood heparin levels. Devices that automatically tilt the tube and detect clot formation facilitate standardization and reproducibility of both WBPTT and ACT. It is for unfractionated heparin monitoring only.
4. **Lee–White clotting time (LWCT).** The Lee–White test is performed by adding 0.4 mL of blood to a glass tube and inverting the tube every 30 seconds until the blood clots. Usually, the blood is kept at room temperature. Disadvantages of the LWCT test include the long period of time required before clotting occurs, extensive use of technician time required, and the relatively poor standardization and reproducibility of the test. LWCT is the least desirable method of monitoring clotting during

hemodialysis. This test is now rarely used.

5. **Activated Factor Xa.** Factor Xa can be measured by chromogenic or functional clotting assays. Laboratory assays of anti-Xa activity differ, as some contain exogenous purified antithrombin (AT), and anti-Xa activity measured using these assays may not necessarily correlate with the biological effect (Greeves, 2002). Although unfractionated heparin can be monitored by Xa activity, this is typically reserved for LMWHs and heparinoids, typically aiming for a peak anti-Xa activity of 0.4–0.6 IU/mL, and <0.2 IU/mL at the end or shortly after completion of dialysis.
6. **Factor Xa-activated ACT.** This test has been proposed as a more sensitive test for monitoring anticoagulation during use of LMWH (Frank, 2004), but is not widely used in clinical practice.

IV. ANTICOAGULATION TECHNIQUES

A. Unfractionated heparin

1. **Mechanisms of action.** Heparin changes the conformation of AT, leading to rapid inactivation of coagulation factors, in particular, factor IIa. Unfortunately, heparin does stimulate platelet aggregation and activation, but these undesirable effects are counterbalanced by interference with binding and activation of coagulation factors at the platelet membrane. Undesired side effects of heparin include pruritus, allergy including anaphylactoid reactions, alopecia, osteoporosis, hyperlipidemia, thrombocytopenia, and excessive bleeding.

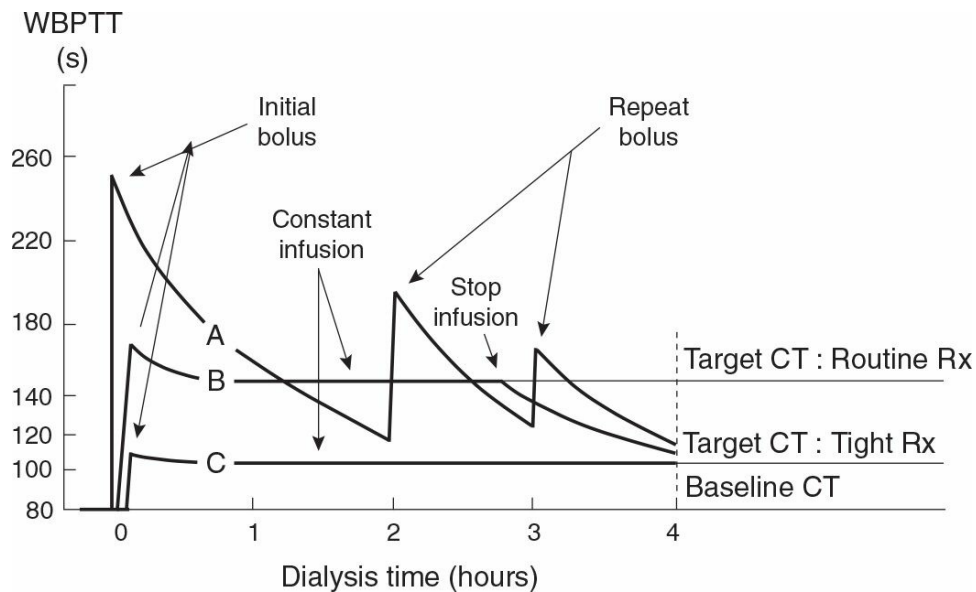

FIGURE 14.1 Effect of various heparin regimens on clotting time as reflected by the WBPTT. Clotting time (CT) using the WBPTT test. **A:** Routine regimen, repeated-bolus method. **B:** Routine regimen, constant-infusion method. **C:** Tight regimen, constant-infusion method.

2. **Target clotting times.** Heparin can usually be given liberally during dialysis without fear of precipitating a bleeding episode in patients who do not exhibit an abnormal bleeding risk. The effect of two routine heparin regimens on clotting time is shown in Figure 14.1. The goal is to maintain WBPTT or ACT at the baseline value plus 80% during

most of the dialysis session (Table 14.3). However, at the end of the session, the clotting time should be shorter (baseline plus 40% for WBPTT or ACT) to minimize the risk of bleeding from the access site after withdrawal of the access needles.

The target clotting times using the Lee–White test are also listed in Table 14.3. With LWCT, in contrast to WBPTT or ACT, the target clotting times during dialysis are considerably greater than baseline plus 80%, and the target LWCT values at the end of the session are greater than baseline plus 40%.

TABLE

14.3

Target Clotting Times During Dialysis

Test	Reagent	Baseline Value	Routine Heparin		Tight Heparin	
			During Dialysis	At End of Dialysis	During Dialysis	At End of Dialysis
APPT ^r		1.0	2.0–2.5	1.5–2.0	1.5–2.0	1.5–2.0
WBPTT	Actin FS	60–85 s	+80% (120–140)	+40% (85–105)	+40% (85–105)	+40% (85–105)
ACT ^a	Siliceous earth	120–150 s	+80% (200–250)	+40% (170–190)	+40% (170–190)	+40% (170–190)
LWCT ^b	None	4–8 min	20–30	9–16	9–16	9–16

ACT, activated clotting time; LWCT, Lee–White clotting time.

^a There are various methods of performing the ACT, and the baseline value with some methods is much lower (e.g., 90–120 sec).

^b Baseline values of the LWCT vary greatly, depending on how the test is performed.

3. **Routine heparin prescriptions.** There are two basic techniques of administering routine heparin. In one method, a heparin bolus is followed by a constant heparin infusion. In the second, a heparin bolus is followed by repeated bolus doses as necessary. For the purpose of discussion, we present a typical prescription in each category.

R_x: Routine heparin, constant-infusion method

Administer the initial bolus dose (e.g., 2,000 units). The initial heparin dose is best administered to the patient via the venous access tubing and flushed in with saline (rather than being infused into the arterial blood line). Introducing heparin into the arterial blood line means that incoming nonheparinized blood will need to be pumped through the dialyzer until the loading dose has had time to pass through the extracorporeal circuit to anticoagulate blood in the body. Wait 3–5 minutes to allow heparin dispersion before initiating dialysis.

Start heparin infusion into the arterial blood line (e.g., at a rate of 1,200 units per hour).

R_x: Routine heparin, single-dose-only or repeated-bolus method

Administer the initial bolus dose (e.g., 4,000 units).

Then give an additional 1,000- to 2,000-unit bolus dose if necessary.

The prescriptions used in the United States, however, vary quite widely. Those centers that reuse dialyzers tend to use more heparin in order to maximize reuse number. Some centers give only a single initial dose (e.g., 2,000 units) of heparin, with no subsequent infusion or boluses. Some centers give a fairly large (75–100 units/kg) initial bolus dose followed by a 500- to 750-unit-per-hour infusion. At this point in time, there has been little research to convincingly demonstrate an optimal method of heparin dosing (Brunet, 2008).

- a. **Effect of body weight on the size of the heparin dose.** Although in a population pharmacokinetic study the volume of distribution of heparin has been found to increase as body weight rises (Smith, 1998), many dialysis centers do not regularly adjust heparin dosage in accordance with body weights ranging between 50 and 90 kg. Some centers do adjust both the loading and maintenance doses according to body weight.
 - b. **Effect of prescription of oral anticoagulants on the size of the heparin dose.** Increasing numbers of elderly patients are prescribed coumarin oral anticoagulants, and newer oral anti-Xa inhibitors (apixaban, rivaroxaban) and direct thrombin inhibitors (dabigatran) are entering medical practice. These newer agents are predominantly renally excreted, and as such are likely to accumulate in dialysis patients and thus increase the risk of bleeding. Most patients on coumarin anticoagulants with an INR of <2.5 still require anticoagulation for dialysis, but those with metallic heart valves who have INR values >3.0 typically do not require heparin. Similarly, patients prescribed aspirin and other antiplatelet agents also require standard heparin dosages, but heparin doses should be reduced or withheld in patients with thrombocytopenia ($<50,000 \times 10^6/L$). There is little clinical data currently on the newer generations of oral anticoagulants, but caution is advised, particularly with the direct thrombin and anti-Xa inhibitors.
 - c. **When to terminate the heparin infusion.** The heparin half-life in dialysis patients averages 50 minutes but ranges from 30 minutes to 2 hours. For a patient with an average heparin half-life of 1 hour, if the heparin infusion during dialysis is prolonging WBPTT or ACT to the required baseline-plus-80% value, stopping heparin infusion approximately 1 hour prior to the end of dialysis will result in the desired WBPTT or ACT value of baseline plus 40% at termination of the session. With venous catheters, heparin infusions are commonly continued right up to the end of dialysis.
 - d. **Posttherapy needle puncture site bleeding.** When this occurs, in addition to reevaluation of the heparin dose, the vascular access (graft or fistula) should be evaluated for the presence of outflow stenosis, as the increased intra-access pressure may be predisposing to posttreatment bleeding. There should also be an evaluation of needle insertion technique. Poor technique and failure to rotate puncture sites can lead to shredding of the wall of a graft so that it leaks following needle removal no matter how well anticoagulation is controlled.
4. **Evaluation of clotting during routine heparinization.** A small incidence of inadvertent clotting of

the extracorporeal system is expected and generally does not necessitate a change in heparin prescription. When clotting occurs, it is useful to evaluate the likely cause. Often, the underlying cause may be correctable (e.g., access revision). Operator-induced errors, as listed in Table 14.4, must be considered and managed through education. Recurrent clotting warrants individual reevaluation and adjustments in heparin dosing.

5. **Bleeding complications of routine heparinization.** The risk of increased bleeding due to systemic anticoagulation is 25–50% in high-risk patients with bleeding gastrointestinal lesions (gastritis, peptic ulcer, angiodysplasia), recent surgery, pericarditis, or thrombocytopenia. De novo bleeding can involve the central nervous system, retroperitoneum, and mediastinum. The tendency to bleed is potentiated by uremia-associated defects in platelet function and possibly by endothelial abnormalities.

B. Tight heparin

1. **General comments.** Tight heparinization schemes are recommended for patients who are at slight risk for bleeding, when the risk of bleeding is chronic and prolonged, and where use of heparin-free dialysis has been unsuccessful because of frequent clotting. When using WBPTT or ACT to monitor therapy, the target clotting time (see Table 14.3 and curve C in Fig. 14.1) is equal to the baseline value plus 40%. Target clotting times using the Lee–White method are given in Table 14.3. If the baseline WBPTT or ACT value is >140% of the average baseline value for patients in the dialysis unit, it is best not to use heparin and to proceed with a heparin-free or regional citrate technique.

TABLE

14.4

Technical or Operator-induced Factors That May Result in Clotting

Dialyzer Priming

Retained air in dialyzer (due to inadequate priming or poor priming technique)
Inadequate priming of heparin infusion line

Heparin Administration

Incorrect heparin pump flow rate setting
Incorrect loading dose
Delayed starting of heparin pump
Failure to release heparin line clamp
Insufficient time delay after loading dose for systemic heparinization to occur

Dialysis Circuit

Kinking of dialyzer outlet blood line

Vascular Access

Inadequate blood flow due to needle/catheter positioning or clotting
Excessive access recirculation due to needle/tourniquet position
Frequent interruption of blood flow due to machine alarms

2. **The tight heparin prescription.** A bolus dose followed by a constant infusion of heparin is the best technique for administering a tight heparin prescription because constant infusion avoids the rising and falling clotting times that are inevitable with repeated-bolus therapy. A typical tight heparin prescription is as follows:

R_x: Tight heparin, constant-infusion method

Obtain baseline clotting time (WBPTT or ACT).

Initial bolus dose = 750 units.

Recheck WBPTT or ACT after 3 minutes.

Administer a supplemental bolus dose if needed to prolong WBPTT or ACT to a value of baseline plus 40%.

Start dialysis and heparin infusion at a rate of 600 units per hour.

Monitor clotting times every 30 minutes.

Adjust the heparin infusion rate to keep WBPTT or ACT at baseline plus 40%.

Continue heparin infusion until the end of the dialysis session.

- C. **Heparin-associated complications.** Apart from bleeding, complications of note are increase in blood lipids, thrombocytopenia, and the potential for hypoaldosteronism and exacerbation of hyperkalemia, especially in patients with substantial residual renal function. Some patients may complain of alopecia.

1. **Lipids.** Heparin activates lipoprotein lipase, and in this way can increase the serum triglyceride concentration. Lower levels of high-density lipoprotein (HDL) cholesterol are associated with higher doses of heparin.

2. **Heparin-induced thrombocytopenia.** There are two types of heparin-induced thrombocytopenia (HIT). In type 1 HIT, the reduction in platelet count occurs in a time- and dose-dependent manner and responds to reduction in heparin dose. In type 2 HIT, there is agglutination of platelets and paradoxical arterial and/or venous thrombosis. Type 2 HIT, which is attributable to the development of immunoglobulin G (IgG) or IgM antibodies against heparin–platelet factor 4 complex, is more commonly induced with bovine versus porcine unfractionated heparin, and least with LMWHs. Given the frequency of HIT in the nondialysis population, it is surprising that it is not encountered more often in a dialysis setting. Diagnosis of type 2 HIT is a clinical diagnosis supported by a positive enzyme-linked immunosorbent assay (ELISA) using bound platelet factor 4 complexed with heparin in combination with an abnormal platelet aggregation test.

LMWH should not be used to treat HIT, because there often is cross-reactivity of the heparin–platelet factor 4 antibodies with these drugs. The alternative anticoagulants of choice include the direct thrombin inhibitor argatroban (Tang, 2005) and the heparinoids danaparoid, and fondaparinux (Haase, 2005). Warfarin should only be introduced once the platelet count has recovered to $>150,000 \times 10^6/L$, as it may lead to skin necrosis and venous limb gangrene if given in the acute phase of the disease (Srinivasan, 2004).

3. **Pruritus.** Heparin can cause local itching when injected subcutaneously, and it has been speculated that heparin may be the cause of itching and other allergic reactions during

dialysis. On the other hand, LMWH has been used to treat the itching associated with lichen planus, on the basis of inhibition of T-lymphocyte heparinase activity (Hodak, 1998). There is no evidence that removal of heparin from the extracorporeal circuit reliably improves uremic pruritus.

4. **Anaphylactoid reactions.** See Chapter 12.
5. **Hyperkalemia.** Heparin-associated hyperkalemia, attributable to heparin-induced suppression of aldosterone synthesis, has been well described. In oliguric dialysis patients, it has been speculated that aldosterone might still aid potassium excretion via a gastrointestinal mechanism (Hottelart, 1998).
6. **Osteoporosis.** Long-term administration of heparin can cause osteoporosis.

D. Heparin-free dialysis

1. **General comments.** Heparin-free dialysis is the method of choice in patients who are actively bleeding, who are at moderate to high risk of bleeding, or in whom the use of heparin is contraindicated (e.g., persons with heparin allergy). The indications for heparin-free dialysis are listed in Table 14.5. Because of its simplicity and safety, many centers now use heparin-free dialysis routinely for most dialysis treatments being given in an intensive care unit setting. Careful priming to minimize blood–air interfaces is important in preventing clotting in the extracorporeal circuit. The dialysis circuitry should be chosen to minimize the length of tubing, avoiding areas of stagnation and turbulence due to changes in internal lumen diameter, and three-way connectors. Platelet activation is reduced by cooling the dialysate.
2. **The heparin-free prescription.** There are a variety of techniques, but all are similar to the one given below.

R_x: Heparin-free dialysis

- a. **Heparin rinse.** (This step is optional. Avoid if heparin-associated thrombocytopenia is present.) Rinse extracorporeal circuit with saline containing 3,000 units of heparin/L so that heparin can coat extracorporeal surfaces and the dialyzer membrane to mitigate the thrombogenic response. To prevent systemic heparin administration to the patient, allow the heparin-containing priming fluid to drain by filling the extracorporeal circuit with either the patient's blood or unheparinized saline at the outset of dialysis.
- b. **Relatively high blood flow rate.** Set the blood flow rate to 300–400 mL/min if tolerated. If a high blood flow rate is contraindicated owing to the risk of disequilibrium (e.g., small patient, very high predialysis plasma urea level), consider giving ultrashort (e.g. 1-hour) periods of dialysis interspersed with periods of isolated ultrafiltration. In addition, one can consider using a small-surface-area dialyzer and/or slowing the dialysate flow rate. Generally, double-lumen hemodialysis catheters deliver sufficiently high blood flows for heparin-free dialysis be effective.

Pericarditis

Recent surgery, with bleeding complications or risk, especially:

Vascular and cardiac surgery

Eye surgery (retinal and cataract)

Renal transplant

Brain surgery

Parathyroid surgery

Coagulopathy

Thrombocytopenia

Intracerebral hemorrhage

Active bleeding

Routine use for dialysis of acutely ill patients by many centers

- c. **Periodic saline rinse.** The utility of this step is controversial; one recent study suggested that use of a saline rinse may actually promote clotting (perhaps via introduction of microbubbles into the circuit) (Sagedal, 2006). The purpose of the periodic rinsing is to allow inspection of a hollow-fiber dialyzer for evidence of clotting and to allow for timely discontinuation of treatment or changing of the dialyzer. Also, periodic saline rinsing is believed by some to reduce the propensity for dialyzer clotting or interfere with clot formation.

Procedure: Rinse the dialyzer rapidly with 250 mL of saline while occluding the blood inlet line every 15 minutes. The frequency of the flushes can be increased or decreased as needed. The use of volumetric control is desirable for the accurate removal of volumes of ultrafiltrate equal to those of the administered saline rinses.

- d. **Dialyzer membrane materials.** Heparin is a very negatively charged molecule that can adsorb to the dialyzer surface, and this has been used to develop heparin-coated dialyzer membranes, which have been reported to allow heparin-free or heparin-reduced dialysis (Evenepoel, 2007).
 - e. **Dialyzer surface area.** Large-surface-area dialyzers theoretically are associated with a higher clotting risk, especially if there is slower flow in the outer fibers; smaller-surface-area dialyzers are designed to provide faster flow in the outer capillary fibers and are preferred.
 - f. **Ultrafiltration and hemodiafiltration.** A very high ultrafiltration rate leads to hemoconcentration and increases the risk of platelet–dialyzer membrane interactions and clot deposition on the dialyzer surface.
 - g. **Blood product transfusion or lipid administration.** Administration via the inlet blood line has been reported to increase clotting risk during dialysis.
- E. **Bicarbonate dialysis solution with low-concentration citrate (Citrasate™).** A small amount of citric acid is used instead of acetic acid as the acidifying agent. When the acid and base concentrates are mixed, the resulting dialysis solution commonly contains 0.8 mmol/L (2.4 mEq/L) citrate. This small amount of citrate, by complexing with calcium, has been suggested to

inhibit blood coagulation and platelet activation locally at the dialyzer membrane surface, resulting in improved dialyzer clearance and increased dialyzer reusability (Ahmad, 2005). This type of dialysis solution can be used with a reduced dose of heparin, or as part of a heparin-free dialysis technique, with a reduced incidence of dialyzer clotting. The amount of citrate used is low enough such that monitoring of ionized calcium is not required.

V. OTHER ANTICOAGULATION TECHNIQUES

- A. **LMWH.** LMWH fractions (molecular weight = 4,000–6,000 Da) are obtained by chemical degradation, enzymatic digestion, or sieving of crude heparin (molecular weight = 2,000–25,000 Da). LMWHs inhibit factor Xa, factor XIIa, and kallikrein, but cause so little inhibition of thrombin and factors IX and XI that partial thromboplastin time and thrombin time are raised by only 35% during the first hour, and are minimally prolonged thereafter, decreasing bleeding risk.

Hemodialysis using LMWHs as the sole anticoagulant has been shown in long-term studies to be safe and effective. LMWH's longer half-life permits anticoagulation with a single dose at the start of dialysis, though split dosing may be better for extended dialysis sessions. Compared with unfractionated heparin, LMWHs have higher bioavailability, with less nonspecific binding to the endothelium, plasma proteins, and platelets. As such, LMWHs have a more rapid onset of action and cause less platelet and leukocyte activation (Aggarwal, 2004) and fibrin deposition on dialyzer surfaces than unfractionated heparin. As LMWHs are smaller molecules, some of the bolus dose may be lost when injected upstream to the dialyzer, particularly during hemodiafiltration treatments (Sombolos, 2009).

LMWHs are now commercially available in the United States, but are not widely used there for hemodialysis because of greater expense and regulatory issues. The dose of LMWH is generally expressed in anti-factor Xa Institute Choay units (aXaICU). A series of LMWHs are available: they differ in molecular weight (MW), half-life, and relative anti-Xa to IIa activity. The characteristics of commonly available LMWHs and usual starting doses are given in Table 14.6. Lower dosages should be used in patients who have a mildly increased risk of hemorrhage. Coagulation tests are not routinely monitored with LMWH treatments, because anti-Xa activity assays are not readily available. A bedside anti-Xa assay has shown promising results to assess tinzaparin anticoagulation levels in one preliminary study (Pauwels, 2014). Potential benefits of LMWH, as discussed above, include ease of administration and more predictable effects, and LMWH may reduce the risk of heparin-induced osteoporosis associated with long-term unfractionated heparin administration (Lai, 2001). The European Best Practice Guidelines recommend use of LMWH over unfractionated heparin.

TABLE

14.6

Commonly Used LMWH Compounds

Name	Molecular Weight (Da)	Anti-Xa/IIa Activity Ratio	Average Dialysis Bolus Dose
Dalteparin	6,000	2.7	5,000 IU
Nadroparin	4,200	3.6	70 IU/kg
Reviparin	4,000	3.5	85 IU/kg
Tinzaparin	4,500	1.9	1,500–3,500 IU
Enoxaparin	4,200	3.8	0.5–0.8 mg/kg

1. **Anaphylactic reactions to bolus low-molecular-weight heparin.** The so-called first-use syndrome (Chapter 12) has been reported not only with unfractionated heparin but also with LMWH. When reactions occur, patients seem to react to all types of heparin. Because heparins are very negatively charged, bradykinin and anaphylatoxins (C3a and C5a) can be generated as heparinized blood passes through the dialyzer, leading to hypotension (Kishimoto, 2008), which may explain the case report of an apparently heparin-allergic patient who could be dialyzed when the heparin was infused using a constant-infusion method but not when a bolus dose was given (De Vos, 2000).
 2. **Bleeding complications.** In chronic kidney disease patients being treated with LMWH who are also receiving clopidogrel and aspirin, bleeding complications have been reported (Farooq, 2004).
- B. **Heparinoids (danaparoid and fondaparinux).** Danaparoid is a mixture of 84% heparin, 12% dermatan, and 4% chondroitin sulfates. Danaparoid affects predominantly factor Xa and therefore has to be monitored with anti-Xa assays. The half-life is prolonged in renal failure such that monitoring is sometimes used to check anti-Xa activity prior to the succeeding dialysis session. In patients >55 kg, a 750-IU loading dose is recommended, while the loading dose can be 500 IU in patients weighing 55 kg or less. Subsequent doses are titrated to achieve an anti-Xa activity of 0.4–0.6 post bolus. Danaparoid may cross-react with HIT antibodies in up to 10% of cases. More recently, a series of synthetic pentasaccharides, such as fondaparinux, have been developed, which do not cross-react with HIT antibodies. A typical predialysis dose is 2.5–5.0 mg. Fondaparinux also has an extended half-life. Anti-Xa monitoring is designed to prevent accumulation of heparinoids, aiming for a predialysis anti-Xa of ≤ 0.2 IU/mL. Hemodiafiltration will increase losses of both danaparoid and fondaparinux, and higher dosages may be required.
- C. **Regional (high-concentration) citrate anticoagulation.** An alternative to heparin-free dialysis is to anticoagulate the blood in the extracorporeal circuit by lowering its ionized calcium concentration (calcium is required for the coagulation process). The extracorporeal blood-ionized calcium level is lowered by infusing trisodium citrate (which complexes calcium) into the arterial blood line and by using a dialysis solution containing no calcium. To prevent the return of blood with a very low ionized calcium concentration to the patient, the process is reversed by infusion of calcium chloride into the dialyzer blood outlet line. About one-third of the infused citrate is dialyzed away and the remaining two-thirds are quickly metabolized by the patient. The advantages of regional citrate anticoagulation over heparin-free dialysis are (a) the blood flow rate does not have to be high and (b) clotting rarely occurs. The principal disadvantages are the requirement for two infusions (one of

citrate and one of calcium) and the requirement for monitoring the plasma-ionized calcium level. Because sodium citrate metabolism generates bicarbonate, use of this method results in a greater-than-usual increment in the plasma bicarbonate value. Hence, regional citrate anticoagulation should be used with caution in patients who are at risk for alkalemia. When citrate anticoagulation is to be used on a long-term basis, the dialysis solution bicarbonate level should be reduced (e.g., to 25 mM) if metabolic alkalosis is to be avoided (van der Meulen, 1992). This technique is not widely used for intermittent hemodialysis but is more popular for the continuous forms of dialysis therapy. One theoretical advantage of citrate anticoagulation is the prevention of platelet activation/degranulation (Gritters, 2006).

- D. **Thrombin inhibitors.** Argatroban, a synthetic peptide derived from arginine, acts as a direct thrombin inhibitor. It is primarily metabolized in the liver. Argatroban is licensed for treating patients with HIT. For hemodialysis, one can give an initial bolus of 250 mcg/kg followed by an infusion starting at 2 mcg/kg/min, or 6–15 mg/hour (Murray 2004), titrated to achieve an APPT_r of 2.0–2.5. As with heparin, the infusion should be stopped 20–30 minutes prior to the end of the dialysis session to prevent excessive bleeding from fistula needle sites. Argatroban is not significantly cleared during high-flux hemodialysis or hemodiafiltration owing to protein binding, but much lower doses are required for those with liver disease (Greinachre 2008). A related drug, melagatran, has been used for anticoagulation when added to the dialysate, but this treatment remains experimental (Flanigan, 2005).

Lepirudin is a recombinant irreversible thrombin inhibitor, which is renally cleared and has a prolonged biological half-life in dialysis patients. The loading dose for intermittent hemodialysis ranges from 0.2–0.5 mg/kg (5–30 mg). Lepirudin is cleared during hemodiafiltration and with most high-flux dialyzers (Benz, 2007). Hirudin antibodies have been reported to develop in approximately one-third of patients, potentiating the anticoagulant effect. Dose adjustments are made to the bolus dose by measuring the APPT_r prior to the subsequent dialysis, aiming for an APPT_r <1.5 to prevent accumulation, but as the APT_r does not correlate with plasma lepirudin concentration, lepirudin assays have now been developed, targeting a therapeutic range of 0.5–0.8 mcg/mL. Bleeding is a major risk, and there is no simple antidote, so fresh frozen plasma or factor VIIa concentrates may be required. Lepirudin may occasionally cause anaphylactoid reactions. Bivalirudin is a reversible direct thrombin inhibitor that has a much shorter half-life than lepirudin. A typical infusion rate is 1.0–2.5 mg/hour (0.009–0.023 mg/kg/hour) adjusted to achieve a target APPT_r of around 1.5–2.0.

- E. **Prostanoids.** Prostacyclin (PGI₂) and its analog epoprostenol are potent antiplatelet agents that block cAMP. They can be used as regional anticoagulants in patients at risk of bleeding. Although PGI₂ is a potent vasodilator, the risk of hypotension can be reduced by starting a systemic infusion at 0.5 ng/kg/min, and steadily increasing to 5 ng/kg/min, and then switching the infusion into the dialysis circuit once dialysis starts, as around 40% of the dose is lost into the dialysate. The half-life is very short, and hypotensive episodes can usually be rapidly reversed by stopping the infusion.
- F. **Nafamostat maleate.** Nafamostat mesilate is a protease inhibitor with a short half-life that can be used as a regional anticoagulant. Most experience comes from Japan, using an initial

bolus dose of 20 mg, followed by an infusion starting at 40 mg/hour, adjusted to maintain a target APPT_r of 1.5–2.0, or ACT of 140–180 seconds.

References and Suggested References

- Aggarwal A. Attenuation of platelet reactivity by enoxaparin compared with unfractionated heparin in patients undergoing haemodialysis. *Nephrol Dial Transplant*. 2004;19:1559–1563.
- Ahmad S, et al. Increased dialyzer reuse with citrate dialysate. *Hemodial Int*. 2005;9:264.
- Apsner R, et al. Citrate for long-term hemodialysis: prospective study of 1,009 consecutive high-flux treatments in 59 patients. *Am J Kidney Dis*. 2005;45:557.
- Benz K, et al. Hemofiltration of recombinant hirudin by different hemodialyzer membranes, implications for clinical use. *Clin J Am Soc Nephrol*. 2007;2:470–476.
- Brunet P, et al. Pharmacodynamics of unfractionated heparin during and after a haemodialysis session. *Am J Kidney Dis*. 2008;51:789–795.
- Caruana RJ, et al. Heparin-free dialysis: comparative data and results in high-risk patients. *Kidney Int*. 1987;31:1351.
- De Vos JY, Marzoughi H, Hombrouckx R. Heparinisation in chronic haemodialysis treatment: bolus injection or continuous homogeneous infusion? *EDTNA ERCA J*. 2000;26(1):20–21.
- European Best Practice Guidelines. V.1–V.5 Hemodialysis and prevention of system clotting (V.1 and V.2); prevention of clotting in the HD patient with elevated bleeding risk (V.3); heparin-induced thrombocytopenia (V.4); and side effects of heparin (V.5). *Nephrol Dial Transplant*. 2002;17(suppl 7):63.
- Evenepoel P, et al. Heparin-coated polyacrylonitrile membrane versus regional citrate anticoagulation: a prospective randomized study of 2 anticoagulation strategies in patients at risk of bleeding. *Am J Kidney Dis*. 2007;49:642–649.
- Farooq V, et al. Serious adverse incidents with the usage of low molecular weight heparins in patients with chronic kidney disease. *Am J Kidney Dis*. 2004;43:531.
- Flanigan MJ. Melagatran anticoagulation during haemodialysis—'Primum non nocere.' *Nephrol Dial Transplant*. 2005;20:1789.
- Frank RD, et al. Factor Xa-activated whole blood clotting time (Xa-ACT) for bedside monitoring of dalteparin anticoagulation during haemodialysis. *Nephrol Dial Transplant*. 2004;19:1552.
- Gotch FA, et al. Care of the patient on hemodialysis. In: Cogan MG, Garovoy MR, (eds). *Introduction to Dialysis*, 2nd ed. New York, NY: Churchill Livingstone; 1991.
- Gouin-Thibault I, et al. Safety profile of different low-molecular weight heparins used at therapeutic dose. *Drug Saf*. 2005;28:333.
- Greaves M. Control of anticoagulation subcommittee of the scientific and standardization committee of the International Society of Thrombosis and Haemostasis: limitations of the laboratory monitoring of heparin therapy. Scientific and standardization committee communications on behalf of the control of anticoagulation subcommittee of the scientific and standardization committee of the International Society of Thrombosis and Haemostasis. *Thromb Haemost*. 2002;87:163–164.
- Greinacher A, Warkentin TE. The direct thrombin inhibitor hirudin. *Thromb Haemost*. 2008;99:819–829.
- Gritters M, et al. Citrate anticoagulation abolishes degranulation of polymorphonuclear cells and platelets and reduces oxidative stress during haemodialysis. *Nephrol Dial Transplant*.

2006;21:153.

- Haase M, et al. Use of fondaparinux (ARIXTRA) in a dialysis patient with symptomatic heparin-induced thrombocytopenia type II. *Nephrol Dial Transplant*. 2005;20:444.
- Handschin AE, et al. Effect of low molecular weight heparin (dalteparin) and fondaparinux (Arixtra) on human osteoblasts in vitro. *Br J Surg*. 2005;92:177.
- Hemmelder MH, et al. Heparin lock in hemodialysis catheters adversely affects clotting times: a comparison of three catheter sampling methods [Abstract]. *J Am Soc Nephrol*. 2003;14:729A.
- Ho G, et al. Use of fondaparinux for circuit patency in hemodialysis patients. *Am J Kidney Dis*. 2013;61:525–526.
- Hodak E, et al. Low-dose low-molecular-weight heparin (enoxaparin) is beneficial in lichen planus: a preliminary report. *J Am Acad Dermatol*. 1998;38:564.
- Hottelart C. Heparin-induced hyperkalemia in chronic hemodialysis patients: comparison of low molecular weight and unfractionated heparin. *Artif Organs*. 1998;22:614–617.
- Kishimoto TK, et al. Contaminated heparin associated with adverse clinical events and activation of the contact system. *N Engl J Med*. 2008;358:2457–2467.
- Krummel T, et al. Haemodialysis in patients treated with oral anticoagulant: should we heparinize? *Nephrol Dial Transplant*. 2014;29:906–913.
- Lai KN, et al. Effect of low molecular weight heparin on bone metabolism and hyperlipidemia in patients on maintenance hemodialysis. *Int J Artif Organs*. 2001;24:447.
- Lim W, et al. Safety and efficacy of low molecular weight heparins for hemodialysis in patients with end-stage renal failure: a meta-analysis of randomized trials. *J Am Soc Nephrol*. 2004;15:3192.
- McGill RL, et al. Clinical consequences of heparin-free hemodialysis. *Hemodial Int*. 2005;9:393.
- Molino D, et al. In uremia, plasma levels of anti-protein C and anti-protein S antibodies are associated with thrombosis. *Kidney Int*. 2005;68:1223.
- Murray PT, et al. A prospective comparison of three argatroban treatment regimens during hemodialysis in end-stage renal disease. *Kidney Int*. 2004;66:2446.
- Olson JD, et al. College of American Pathologists Conference XXXI on laboratory monitoring of anticoagulant therapy: laboratory monitoring of unfractionated heparin therapy. *Arch Pathol Lab Med*. 1998;122:782–798.
- Ouseph R, et al. Improved dialyzer reuse after use of a population pharmacodynamic model to determine heparin doses. *Am J Kidney Dis*. 2000;35:89.
- Pauwels R, et al. Bedside monitoring of anticoagulation in chronic haemodialysis patients treated with tinzaparin. *Nephrol Dial Transplant*. 2014;29:1092–1096.
- Sagedal S, et al. Intermittent saline flushes during haemodialysis do not alleviate coagulation and clot formation in stable patients receiving reduced doses of dalteparin. *Nephrol Dial Transplant*. 2006;21:444.
- Schwab SJ, et al. Hemodialysis without anticoagulation: one year prospective trial in hospitalized patients at risk for bleeding. *Am J Med*. 1987;83:405.
- Smith BP, et al. Prediction of anticoagulation during hemodialysis by population kinetics in an artificial neural network. *Artif Organs*. 1998;22:731.
- Sombolos KI, et al. The anticoagulant activity of enoxaparin sodium during on-line hemodiafiltration and conventional haemodialysis. *Haemodial Int*. 2009;13:43–47.
- Srinivasan AF, et al. Warfarin-induced skin necrosis and venous limb gangrene in the setting of

heparin-induced thrombocytopenia. *Arch Int Med*. 2004;164:66.

Tang IY, et al. Argatroban and renal replacement therapy in patients with heparin-induced thrombocytopenia. *Ann Pharmacother*. 2005;39:231.

Van Der Meulen J, et al. Citrate anticoagulation and dialysate with reduced buffer content in chronic hemodialysis. *Clin Nephrol*. 1992;37:36–41.

Wright S, et al. Citrate anticoagulation during long term haemodialysis. *Nephrology (Carlton)*. 2011;6:396–402.

Zhang W, et al. Clinical experience with nadroparin in patients undergoing dialysis for renal impairment. *Hemodial Int*. 2011;15:379–394.

The most widely used continuous renal replacement therapies (CRRT) for the treatment of critically ill patients in renal failure are continuous hemodialysis and hemodiafiltration. Two prolonged intermittent renal replacement therapies (PIRRT), sustained low-efficiency hemodialysis and sustained low-efficiency hemodiafiltration, are also quite popular. Continuous hemofiltration and slow continuous ultrafiltration are used, but less commonly.

- I. **NOMENCLATURE.** In the *Handbook*, we abbreviate continuous hemodialysis as C-HD, whether it is applied using an arteriovenous (AV) or venovenous access. Similarly, continuous hemofiltration is abbreviated as C-HF, and their combination, slow continuous hemodiafiltration, is C-HDF. Historically, one would insert “AV” or “VV” after the letter “C” to specify that the therapy was given using either an AV or a venovenous access, giving CAVHD or CVVHD (hemodialysis), CAVH or CVVH (hemofiltration), and CAVHDF or CVVHDF (hemodiafiltration); but today, most treatments are given using a venous catheter-based access, and so use of the “VV” has become superfluous. Slow continuous ultrafiltration is abbreviated as SCUF, and sustained low-efficiency hemodialysis and hemodiafiltration are abbreviated as SLED and SLED-F, respectively. SLED and SLED-F are collectively grouped as forms of prolonged intermittent renal replacement therapy, or PIRRT. Conventional intermittent treatment is called IHD (intermittent hemodialysis) or, more generally, IRRT (intermittent renal replacement therapy), given that the intermittent treatment being given is not always hemodialysis.
 - A. **What are the differences among C-HD, C-HF, and C-HDF?** Each of these procedures involves slow, continuous passage of blood, taken from either an arterial or a venous source, through a filter. Table 15.1 shows a comparison of these techniques.
 1. **Continuous hemodialysis (C-HD).** In C-HD (Fig. 15.1), dialysis solution is passed through the dialysate compartment of the filter continuously and at a slow rate. In C-HD, diffusion is the primary method of solute removal. The amount of fluid that is ultrafiltered across the membrane is low (usually about 3–6 L per day) and is limited to excess fluid removal.

	IHD	SLED	SCUF	C-HF	C-HD	C-HDF
Membrane permeability	Variable	Variable	High	High	High	High
Anticoagulation	Short	Long	Continuous	Continuous	Continuous	Continuous
Blood flow rate (mL/min)	250–400	100–200	100–200	200–300	100–300	200–300
Dialysate flow rate (mL/min)	500–800	100	0	0	16–35	16–35
Filtrate (L per day)	0–4	0–4	0–5	24–96	0–4	24–48
Replacement fluid (L per day)	0	0	0	22–90	0	23–44
Effluent saturation (%)	15–40	60–70	100	100	85–100	85–100
Solute clearance mechanism	Diffusion	Diffusion	Convection (minimal)	Convection	Diffusion	Diffusion + convection
Urea clearance (mL/min)	180–240	75–90	1.7	17–67	22	30–60
Duration (hr)	3–5	8–12	Variable	>24	>24	>24

C-HD, slow continuous hemodialysis; C-HF, slow continuous hemofiltration; C-HFD, slow continuous hemodiafiltration; IHD, intermittent hemodialysis; SCUF, slow continuous ultrafiltration; SLED, sustained low-efficiency dialysis.

Modified from Metha RL. Continuous renal replacement therapy in the critically ill patient. *Kidney Int.* 2005;67:781–795.

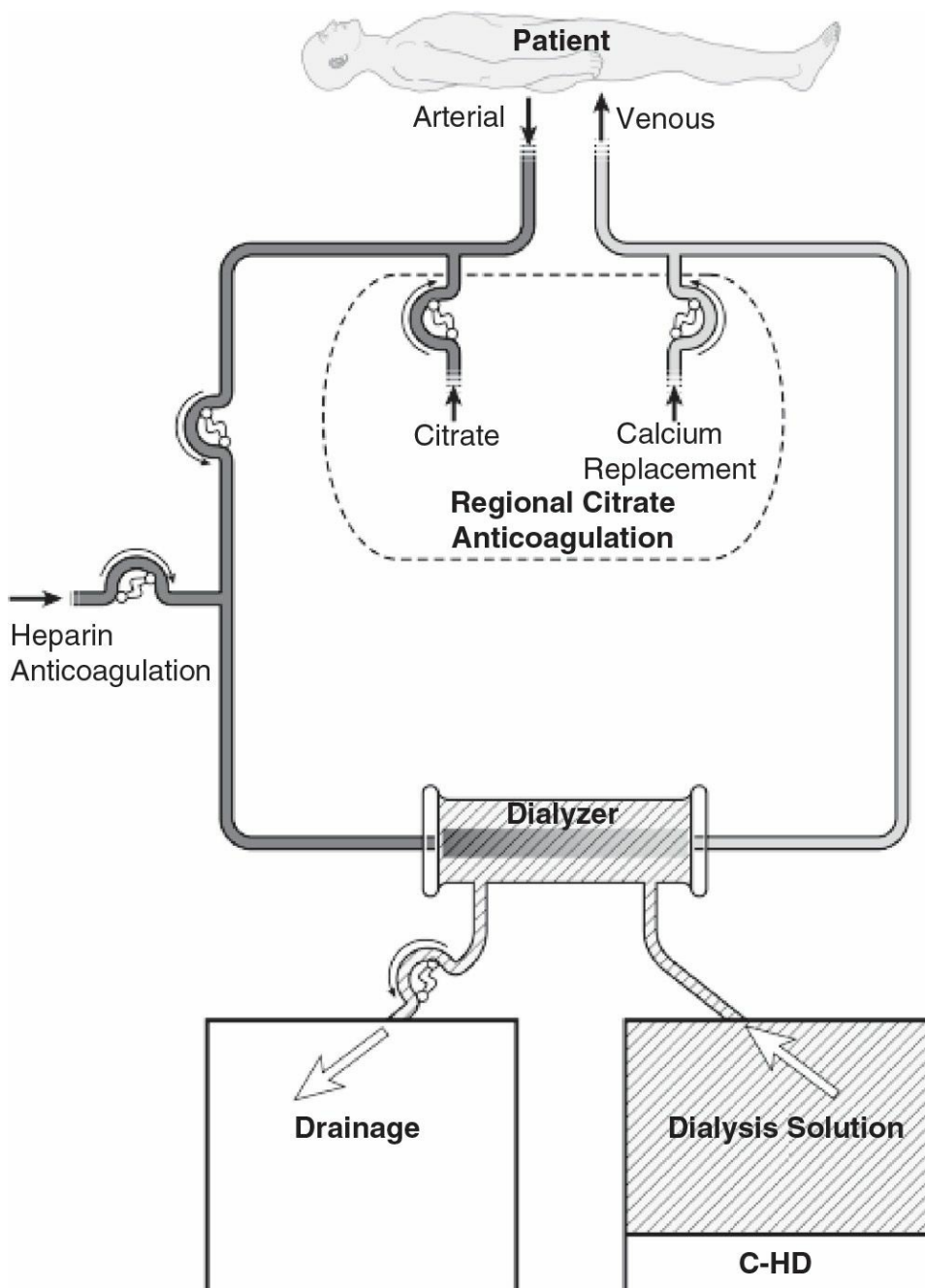

FIGURE 15.1 Typical circuit for slow continuous hemodialysis. Anticoagulation with either heparin or regional citrate is shown. For slow continuous ultrafiltration, the circuit is the same, except that

dialysis solution inflow is not used.

2. **Continuous hemofiltration (C-HF).** In C-HF (Fig. 15.2), dialysis solution is not used. Instead, a large volume (about 25–50 L per day) of replacement fluid is infused into either the inflow or the outflow blood line (predilution or postdilution mode, respectively). With C-HF, the volume of fluid that is ultrafiltered across the membrane is the sum of replacement fluid and excess fluid removed, and so is much higher than with C-HD.

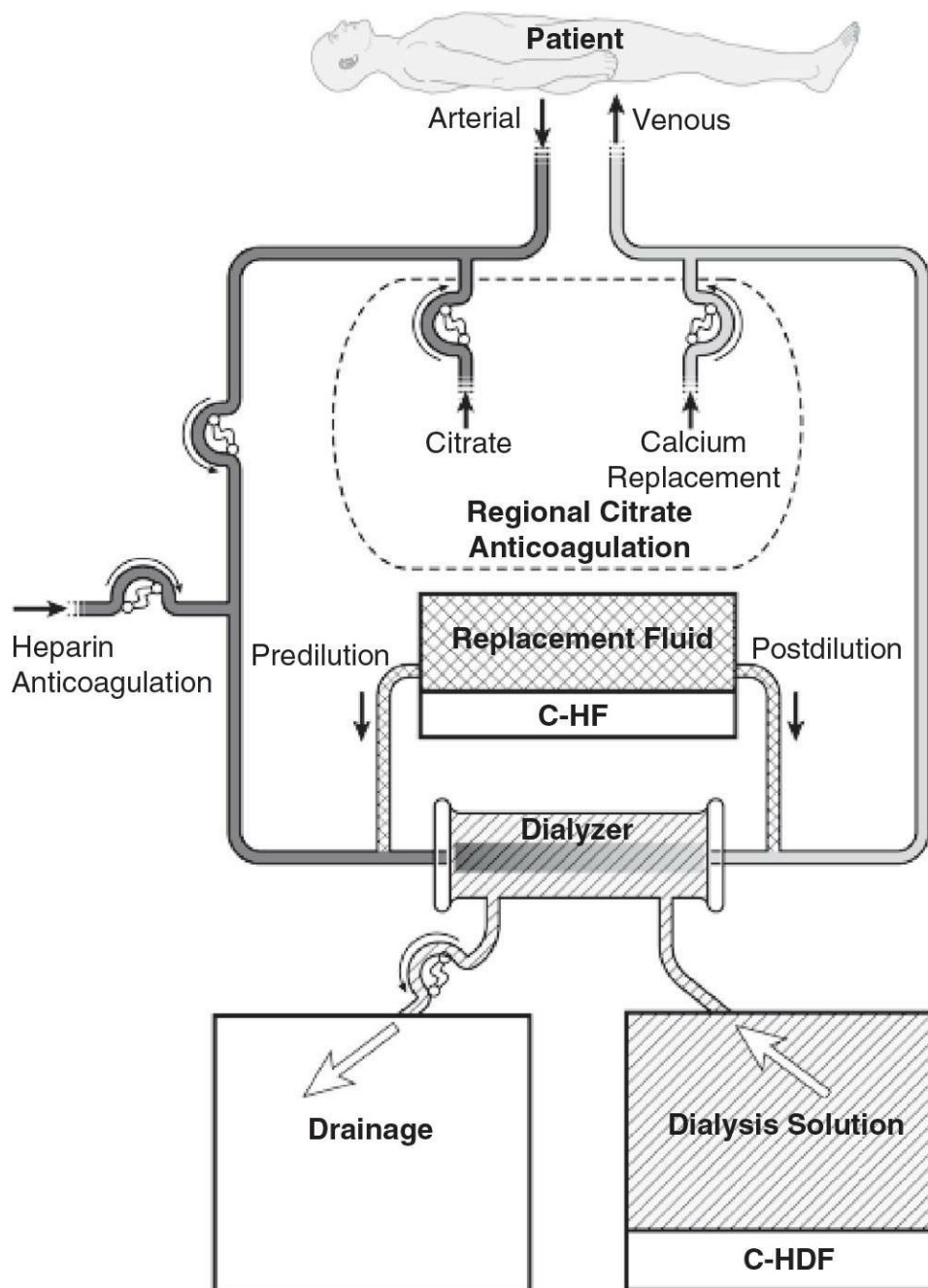

FIGURE 15.2 Typical circuit for continuous hemofiltration and slow continuous hemodiafiltration. In slow continuous hemofiltration (C-HF), replacement fluid can be infused in the predilution mode, or postdilution mode, or both simultaneously. In slow continuous hemodiafiltration, hemodialysis is performed concurrently with C-HF. Anticoagulation with either heparin or regional citrate is shown.

3. **Continuous hemodiafiltration (C-HDF).** This (Fig. 15.2) is simply a combination of

C-HD and C-HF. Dialysis solution is used, and replacement fluid is also infused into either the inflow or the outflow blood line. The daily volume of fluid that is ultrafiltered across the membrane is equal to the replacement fluid infused plus the net volume removed. Usually, the replacement fluid volume with C-HDF is about half that used with C-HF, but the total effluent volume (replacement fluid + dialysis solution + excess fluid volume removed) with C-HDF is similar to that with C-HF, where effluent volume is the sum of replacement fluid and excess fluid volume only.

4. **Slow continuous ultrafiltration (SCUF).** The setup is similar to that for C-HD and C-HF, but neither dialysis solution nor replacement fluid is used. Daily ultrafiltered fluid volume across the membrane is low (usually about 3–6 L per day), similar to C-HD.

B. **Sustained low-efficiency dialysis and hemodiafiltration (SLED and SLED-F).** SLED is a form of IHD using an extended (6- to 10-hour) session length and reduced blood and dialysate flow rates. Typically, blood flow rates (BFRs) are about 200 mL/min and dialysate flow rate is 100–300 mL/min. Regular hemodialysis equipment can be used as long as low blood and dialysate flow rates are supported; a software update may be required with certain dialysis machines to provide the lower rates. The same machine used for IHD during the day often can be used for SLED during the night, and hemodialysis nurses can easily be trained to perform SLED, offering some economy of staff instruction. SLED allows units where CRRT equipment or personnel are unavailable or limited to offer a treatment modality that should achieve similar benefits as CRRT. SLED-F requires additional infusion of replacement fluid unless replacement fluid can be made from dialysis solution online by the dialysis machine (Marshall, 2004).

II. **CLINICAL INDICATIONS FOR CRRT VERSUS INTERMITTENT RENAL REPLACEMENT THERAPY.** The potential advantages of the various CRRT procedures as well as SLED are listed in Table 15.2. They include a lower rate of fluid removal as well as enhanced control of azotemia when compared with standard IHD. Despite the seemingly obvious advantages of slow continuous therapies, there has been no evidence from several randomized trials that, in the acute renal failure setting, use of CRRT offers a survival advantage over IHD (Rabindranath, 2007). However, most trials excluded the sickest patients from treatment with conventional IHD. The 2012 KDIGO Guidelines for acute kidney injury (AKI) suggest (level 2B evidence) that clinicians use CRRT rather than standard IRRT for hemodynamically unstable patients, and also suggest using CRRT to treat AKI patients with acute brain injury or other causes of increased intracranial pressure or generalized brain edema (KDIGO AKI, 2012). However, the guidelines recognize that the use of prolonged IRRT therapies such as SLED or SLED-F may be as useful to treat hemodynamically unstable patients as CRRT, but point to the paucity of outcomes trials comparing CRRT with prolonged IRRT. Some early comparisons (Van Berendoncks, 2010; Marshall 2011) suggest that outcome results with prolonged IRRT are similar to those of CRRT, and that considerable cost savings are achieved with prolonged IRRT.

1. Hemodynamically well tolerated; smaller change in plasma osmolality.
 2. Better control of azotemia and electrolyte and acid–base balance; correct abnormalities as they evolve; steady-state chemistries.
 3. Highly effective in removing fluid (postsurgery, pulmonary edema, ARDS).
 4. Facilitates administration of parenteral nutrition and obligatory intravenous medications (i.e., pressor, inotropic drugs) by creating unlimited “space” by virtue of continuous ultrafiltration.
 5. Less effect on intracranial pressure.
 6. New user-friendly machines available.
-

III. TRAINING AND EQUIPMENT COSTS. The use of continuous procedures requires an effort on the part of nursing staff in the ICU to become familiar with the procedures. In units with high staff turnover rates and in units where continuous therapies are done infrequently, use of prolonged intermittent therapies such as SLED may be a more practical option. However, in high-volume units where continuous therapies are a common part of the dialysis armamentarium, use of such therapies can aid in the fluid, solute, and nutritional management of the most challenging patients.

IV. DIFFERENCES AMONG C-HD, C-HF, AND C-HDF IN CLEARANCE OF SMALL- AND LARGE-MOLECULAR-WEIGHT SOLUTES

A. Solute clearance with C-HD. In C-HD, where the BFR is 150–200 mL/min or more, and dialysate flow rate typically is 25–30 mL/min, clearance of urea and other small molecules is determined primarily by the dialysis solution flow rate. As a rule of thumb, BFR in C-HD should be at least three times the dialysate flow rate. At this slow BFR and high blood-to-dialysate flow ratio, the outflow dialysate is almost 100% saturated with urea and other small-molecular-weight (MW) solutes. Urea clearance can thus be simply estimated by the effluent volume, which includes the volume of dialysis solution used plus any excess fluid removed.

The standard dialysis solution inflow rate is now about 20–25 mL/kg per hour. In a 70-kg individual, this translates into a flow rate of 23–29 mL/min. If we assume a flow rate of 26 mL/min and 100% saturation, this will deliver a urea clearance of 26 mL/min or about 37 L per day, and if we add 3 L per day of excess fluid removal, this gives a daily effluent volume and urea clearance of $37 + 3 = 40$ L. In terms of urea kinetics, this 40 L can be thought of as the familiar ($K \times t$) measure of clearance. For a patient with a urea distribution volume of 40 L, such a prescription would translate to a daily Kt/V of $40/40 = 1.0$ or about 7.0 per week. This compares favorably with an equivalent weekly Kt/V urea delivered by thrice-weekly IHD of about 2.7 (see Chapter 3 to find out how equivalent weekly Kt/V urea is calculated).

B. Solute clearance with C-HF. C-HF is a purely convection-based blood cleansing technique. As blood flows through the hemofilter, a transmembrane pressure gradient between the blood compartment and the ultrafiltrate compartment causes plasma water to be filtered across the highly permeable membrane. As the water crosses the membrane, it sweeps along with it (nonprotein-bound) small and large molecules (pore size permitting) and thus leads to

their removal from the blood. The removed ultrafiltrate is replaced by a balanced electrolyte solution infused into either the inflow (predilution) or the outflow (postdilution) line of the hemofilter. Typically, about 20–25 mL/kg per hour of replacement fluid is infused. The filter outflow or “drainage fluid” is nearly 100% saturated with urea when postdilution mode is used.

1. **Filtration fraction.** This is the fraction of plasma flowing through the hemofilter that is removed. Filtration fraction can be calculated as the ultrafiltration rate divided by the plasma flow rate. The latter is simply $BFR \times (1 - Hct)$. For example, if the BFR is 150 mL/min and the Hct is 33%, the plasma flow rate will be $0.67 \times 150 = 100$ mL/min. If the UF rate is 25 mL/min, then the filtration fraction is $25/97$, or about 25%. The rule of thumb is to keep the filtration fraction at 25% or lower to avoid overconcentration of red cells and plasma proteins in the hemofilter. Overconcentration results in fouling of the membrane pores, which can impair UF efficiency and lower the sieving coefficient, and overconcentration can also increase the likelihood of clotting. To avoid overconcentration and keep filtration fraction below 25%, when a high replacement fluid infusion rate in postdilution mode is desired, the BFR needs to be increased above the usual 150 mL/min.
 2. **Predilution mode.** Another way to keep the filtration fraction from increasing is to use predilution mode. With predilution, there is slight lowering of the urea concentration of ultrafiltrate (usually 80%–90% of the corresponding plasma value), but this is outweighed by the ability to deliver an increased replacement solution infusion rate, enhancing overall middle-molecule clearances. We recommend using predilution whenever it is desirable to remove more than 25 L per day. Predilution is also performed if the baseline blood viscosity is relatively elevated (e.g., if the hematocrit is $>35\%$). A combination of pre- and postdilution has been advocated by some practitioners.
 3. **Calculating the dilutional effects of predilution mode.** As an example, assume that the replacement fluid infusion rate is 25 mL/min and BFR is 150 mL/min. The amount of dilution of waste products in the blood entering the filter will be $25/(150 + 25) = 14\%$. Assuming that 35 L per day of replacement fluid is used and that 5 L per day of excess fluid is removed, daily effluent volume will typically be about 40 L per day. In postdilution mode, $(K \times t)$ will be 40 L. In predilution mode, $(K \times t)$ will be perhaps 15% less, 34 L, and so, assuming $V = 40$ L, then daily Kt/V with C-HF will be about $40/40 = 1.0$ (postdilution) or $34/40 = 0.85$ (predilution).
- C. **Urea clearance with C-HDF.** With C-HDF, the sum of the dialysis solution flow rate, replacement fluid infusion rate, and removal of excess fluid usually is set at a level similar to the outlet flow rate in C-HD or postdilution C-HDF. The clearance calculations are similar to those discussed above. The clearance of small molecules with C-HDF is similar to that with C-HD and C-HF when the daily effluent volumes are comparable.
- D. **Small- versus middle-molecular-weight solute removal with C-HF versus C-HD.** With C-HD, the outflow dialysate is not as highly saturated with larger-MW substances that diffuse slowly in solution and thus have a lower rate of diffusive transfer across the dialyzer membrane. In contrast, with C-HF, the plasma ultrafiltrate is almost completely saturated with both low-

and middle-MW solutes, because the convective removal rates of small- and larger-MW solutes are similar. Hence, C-HF is more efficient than C-HD in terms of larger-MW toxin removal, including peptides, certain antibiotics, and vitamin B₁₂. The theoretical advantage of C-HF is technically demanding to realize, as it can be challenging to ultrafilter >25 L from patients who cannot deliver the high BFRs required to prevent overconcentration. Also, fluid balancing becomes critical when the replacement fluid infusion rate is high. With high-volume C-HF, any slowing of the BFR will result in transient hemoconcentration in the hemofilter, with attendant risk of clotting. On the other hand, it is easy to perform C-HD using dialysis solution flow rates of 50 L per day. For this reason, in daily practice, C-HD tends to be the more popular therapy, and if enhanced removal of middle molecules is desired, a replacement fluid component is added (C-HDF).

1. **Filter surface area and clearance of larger-MW substances:** One in vitro study of clearance of larger-MW substances by C-HF versus C-HD with two different-sized filters (0.4 vs. 2.0 m²) came up with some counterintuitive results: with the larger membrane, the clearance of large-MW substances was identical with C-HD and C-HF, and with the smaller (0.4-m² membrane), clearance of large-MW substances was actually worse with C-HF than with C-HD (Messer, 2009). The proposed explanation was increased protein fouling of the smaller membrane in C-HF mode. These results suggest that using a high replacement fluid flow rate with a small hemofilter may not be an efficient way to increase removal of larger, middle molecules.

V. VASCULAR ACCESS

- A. **Venovenous blood access.** Vascular access is obtained using a dual-lumen cannula inserted into a large (internal jugular or femoral) vein. The subclavian vein can be used but is not the site of first choice. See Chapter 7. The 2012 KDIGO AKI guidelines recommend using uncuffed venous catheters for CRRT (5.4.1). The level of evidence for this is weak (2D). The rationale is that insertion of an uncuffed catheter is easier, that the need for a cuffed catheter might sometimes delay initiation of therapy, and that the average duration of CRRT is only 12–13 days (KDIGO, 2012). One study (Morgan, 2012) compared use of longer (20–24 cm) soft, silicone temporary catheters for CRRT, targeting placement of the catheter tip near the right atrium, versus shorter (15–20 cm) catheters targeting placement of the catheter tip in the superior vena cava; the longer catheters were associated with longer filter life and improved dose of therapy. In another study looking at the success rate of CRRT achieved by femoral venous access, filter longevity averaged 15 hours when the venous catheter was inserted on the right side versus 10 hours when the left femoral vein was used (Kim, 2011). The mechanism of the advantage of right-sided femoral catheters was not clear.
- B. **Arteriovenous blood access.** One can cannulate a large artery, usually the femoral artery, and propel blood through the extracorporeal circuit by using the patient's own arterial pressure instead of a pump. Blood is returned via any large vein. Use of AV blood access for CRRT is no longer widely practiced. There is risk of damage to the femoral artery with possible distal limb ischemia, plus AV access will often not deliver high enough blood flows to be able to support the more intensive CRRT therapies in common use today. However, CRRT

using AV access may be lifesaving in situations where a mass catastrophe has occurred (e.g., earthquake with renal injury due to rhabdomyolysis) and electrical power sources are unreliable, because blood flow is then driven by a patient's own blood pressure and ultrafiltration is adjusted by using gravity (or clamp) via the height of the effluent collection container. For a detailed description of CRRT using an AV access, please refer to the third edition of the *Handbook*.

- C. **Catheter changes: Scheduled changes versus changing only when clinically indicated.** CRRT catheters should be changed only when clinically indicated; catheters should not be changed according to some predetermined schedule in the hopes of minimizing the rate of catheter sepsis. The practice of routine, scheduled catheter changes, once popular, is not recommended by the Centers for Disease Control and Prevention (CDC), and studies do not support this approach.

VI. **CRRT FILTERS.** The terms “hemofilter” and “dialyzer” are used interchangeably in this chapter. Hemofilters have only one outlet in the housing, making use of dialysis solution impossible. Dialyzers have a second port. Dialyzers used for CRRT should have high water permeability, and so will be in the “high-flux” category. Some of the early filters designed primarily for C-HF had excellent water permeability and convective solute clearance, but had poor diffusive clearance when used for C-HD; there was poor optimization of contact between dialysis solution and all parts of the membrane in these filters. Currently used CRRT filters allow urea in the blood compartment of the filter to equilibrate promptly with dialysate, making them suitable for both C-HF and C-HD.

- A. **Filter surface area and size.** The size of the filter should take the BFR into account. When large filters are used at low BFRs, the risk of clotting may be increased, as such filters will have been designed for much higher BFRs. Flow velocity through each fiber will be slow. Furthermore, the permeation of the fiber bundle by dialysis solution may be suboptimal with large dialyzers designed to be used at high dialysate flow rates. On the other hand, larger dialyzers can be used at higher BFRs such as those in some higher-efficiency SLED protocols, in order to maximize middle-molecule solute clearances. The study by Messer et al. (2009) described above also suggests that use of a larger-size filter might be considered when removal of larger-MW solutes is desired and a high replacement fluid rate is to be used.

VII. **DIALYSATES AND REPLACEMENT SOLUTIONS.** CRRT fluids come premixed as commercially prepared sterile solutions. They are typically packaged in 2.5-L or 5-L bags; in some cases fluids are supplied in bags with two compartments that need to be mixed immediately prior to use.

- A. **Composition.** Table 15.3 lists the composition of some commonly available commercially prepared solutions for CRRT.
 - 1. **Buffers.** Solutions contain either lactate or bicarbonate.
 - a. **Lactate-based solutions.** Pure lactate-based replacement fluid usually contains 40–46 mM of lactate. Lactate-based solutions effectively correct metabolic acidosis in most patients. Lactate is metabolized on a 1:1 molar basis to bicarbonate, but in

practice, the dialysis solution lactate concentration needs to be higher than dialysis solution bicarbonate to effect similar degrees of correction of acidosis.

- b. **Bicarbonate-based solutions.** Bicarbonate-containing bags are sold as two-compartment systems, similar to those used to prepare bicarbonate-containing dialysis solution for peritoneal dialysis. Bicarbonate is the buffer of choice, and total base concentrations are typically 25–35 mM. Some solutions contain a small amount (3 mM) of lactate, left over from lactic acid used to acidify the final solution. There is no evidence that this small amount of lactate contributes to hyperlactatemia.

When a high dialysis solution or replacement solution flow rate (e.g., >30 mL/kg/hour) is prescribed, use of lower bicarbonate solutions may help prevent metabolic alkalosis. Lower bicarbonate concentration solutions or bicarbonate-free solutions are also indicated when using regional citrate anticoagulation, because citrate is metabolized to bicarbonate by the liver.

- c. **When high-lactate solutions should be used with caution:** Use of solutions using lactate as the primary bicarbonate-generating base has been shown to worsen hyperlactatemia in patients who have severe circulatory instability with tissue hypoperfusion, and in patients with severe liver compromise. The 2012 KDIGO AKI guidelines suggest using bicarbonate-based solutions for all patients with AKI at a low level of evidence (2C), but recommend using such solutions more strongly for patients with liver failure and/or lactic acidosis (level of evidence 2B) and for patients in circulatory shock (level of evidence 1B).

TABLE

15.3

Composition of Some Continuous Renal Replacement Therapy Solutions

Component (mM)	Dialysis Machine Generated ^a	Peritoneal Dialysis Fluid ^b	Lactated Ringer Solution	B. Braun Duosol (5-L bag)	Baxter Accusol ^b (2.5-L bag)	Gambro PrismaSol ^c (5-L bag)	Nxstage Pureflow ^d (5-L bag)
Sodium	140	132	130	136 or 140	140	140	140
Potassium	Variable	—	4	0 or 2	0 or 2 or 4	0 or 2 or 4	0 or 2 or 4
Chloride	Variable	96	109	107–111	109.5–116.3	106–113	111–120
Bicarbonate	Variable	—	—	25 or 35	30 or 35	32	25 or 35
Calcium	Variable	1.75 (3.5 mEq/L)	1.35 (2.7 mEq/L)	0 or 1.5 (0 or 3.0 mEq/L)	1.4 or 1.75 (2.8 or 3.5 mEq/L)	0 or 1.25 or 1.75 (0 or 2.5 or 3.5 mEq/L)	0 or 1.25 or 1.5 (0 or 2.5 or 3.0 mEq/L)
Magnesium	0.75 (1.5 mEq/L)	0.25 (0.5 mEq/L)	—	0.5 or 0.75 (1.0 or 1.5 mEq/L)	0.5 or 0.75 (1.0 or 1.5 mEq/L)	0.5 or 0.75 (1.0 or 1.5 mEq/L)	0.5 or 0.75 (1.0 or 1.5 mEq/L)
Lactate	2	40	28	0	0	3	0
Glucose (mg/dL)	100	1,360	—	0 or 100	0 or 100	0 or 100	100
Glucose (mM)	5.5	75.5	—	0 or 5.5	0 or 5.5	0 or 5.5	5.5
Preparation method	6-L bag via membrane filtration	Premix	Premix	Two-compartment bag	Two-compartment bag	Two-compartment bag	Two-compartment bag
Sterility	No	Yes	Yes	Yes	Yes	Yes	Yes

- d. **Citrate-based solutions.** These fluids evolved from attempts to merge the buffering and anticoagulation properties of citrate, and the need to simplify complex regional citrate anticoagulation (RCA) protocols. The bulk of citrate-based fluids have to be administered prefilter to allow adequate filter anticoagulation. Forty to 60% of citrate infused in predilution mode is removed in the effluent, and the remainder is mainly metabolized by the liver into bicarbonate (1 mmol citrate yielding 3 mmol bicarbonate). Therefore, it is not appropriate to use these solutions in C-HD where dialysate flow is countercurrent to blood, or C-HF/HDF with predominantly postfilter replacement. Preparations containing citrate at concentrations of 11–12 mM may not provide adequate buffering capacity (Naka, 2005). Fluids with a higher citrate concentration (14 mM) provide better acidosis correction with

improved filter life (Egi, 2005, 2008). Citrate-based solutions at 18 mM are available but the acid–base consequences have not been adequately studied. It is best to infuse citrate-containing replacement fluid predilution, adjusting the flow to achieve an optimum prefilter citrate to blood flow ratio, and then additional solute removal can be achieved by using bicarbonate-based solutions given either as dialysate or postdilution replacement fluid. Additional methods of citrate anticoagulation as well as potential advantages of this approach are discussed later in this chapter.

2. **Sodium.** Commercially available CRRT fluids usually contain physiologic sodium concentrations at or close to 140 mM. When treating patients with severe, and especially longstanding, hyponatremia, where the goal is to slowly increase the serum sodium at a rate no greater than 6-8 mmol/L per day, the replacement fluid or dialysis solution needs to be diluted with water, to a concentrate just slightly greater than the predialysis sodium value. For details please see Yessayan et al (2014). In some anticoagulation methods requiring infusion of trisodium citrate into the blood lines, custom-made, low-sodium (100 mM) dialysis/replacement solutions can be used to limit the occurrence of hypernatremia.
3. **Potassium.** CRRT fluids with no potassium are suitable for initial treatment of AKI patients with severe hyperkalemia. Once serum potassium has decreased to a safe level, fluids containing 4 mM potassium are used to minimize arrhythmia risk and depletion of body potassium. Commercially made fluids come premixed with potassium concentrations of 0, 2, or 4 mM. The lower potassium content solutions also may be used as needed in patients who are highly catabolic with persistent hyperkalemia.
4. **Phosphate.** Hypophosphatemia during extended CRRT is common and can result in respiratory muscle weakness and prolonged respiratory failure in critically ill patients (Demirjian, 2011). Phosphate replacement for severe hypophosphatemia is routine, but frequent monitoring of serum phosphorus levels is necessary. Off-label addition of phosphate to CRRT fluid to maintain a level of 1.2 mM has been reported to maintain serum phosphorus with good clinical efficacy (Trojanov, 2004). A replacement solution containing phosphate at 1.2 mM and bicarbonate at 30 mM is available, but its use has been associated with mild metabolic acidosis and hyperphosphatemia compared with conventional CRRT fluids (Chua, 2012). The ideal fluid phosphate content should probably be lower, and further research is desirable.

AKI has been reported after phosphate enemas and after IV phosphorus infusion. In one audit, infusion of an IV solution of sodium/potassium phosphate containing 20 mM phosphate over an average of 5 hours was not associated with elevation of creatinine in patients with residual kidney function, but was associated with some reduction in ionized calcium concentration (Agarwal, 2014).

5. **Calcium and magnesium.** Most dialysis/replacement solutions contain 1.5–1.75 mM of calcium and 0.5–0.6 mM of magnesium, and their use usually allows maintenance of desired systemic levels. During RCA, citrate binds to and depletes serum calcium and magnesium. CRRT solutions used during RCA often contain no calcium to facilitate

reduction of ionized calcium in the filter by citrate to allow adequate circuit anticoagulation. With RCA, separate systemic infusions of calcium and sometimes magnesium with strict monitoring protocols are thus necessary.

6. **Glucose.** Modern CRRT solutions are either glucose free, or contain physiologic glucose concentrations, usually 5.5 mM (100 mg/dL). Use of glucose-free fluids in CRRT is associated with hypoglycemia, and glucose-containing CRRT fluids are preferred; regular monitoring and administration of insulin is necessary to prevent hyperglycemia and to achieve a target serum glucose of 6–8 mM, a level that has been associated with the best outcomes. Another argument against use of glucose-free CRRT solutions is that substantial amounts of glucose can be removed from the body with their use, and this may adversely affect nutritional balance (Stevenson, 2013).

B. Methods of preparing bicarbonate-based CRRT solutions when prepackaged solutions are not available. Customized solutions can be prepared in the pharmacy, or by the dialysis machine in the form of ultrapure solutions; the latter is appropriate only in countries where regulatory approval for online hemodiafiltration has been granted. One can prepare sterile dialysis/replacement fluid manually to achieve solutions containing 30–35 mM bicarbonate. Bicarbonate is in equilibrium with carbonic acid, which breaks down to CO_2 and H_2O ; therefore, bicarbonate solutions are unstable. Bicarbonate also forms insoluble salts when in solution with calcium and magnesium. Therefore, bicarbonate-based dialysis/replacement solutions should be prepared just before use.

1. **Single-bag method.** Dialysis or replacement solution containing bicarbonate and no lactate is made by adding (usually this is done by the hospital pharmacy service) NaHCO_3 and some additional NaCl to 0.45% NaCl obtained commercially. A small amount of $\text{CaCl}_2 \cdot 2\text{H}_2\text{O}$ is added as well, and magnesium is given parenterally as needed.

Formulation: 1.0 L of 0.45% NaCl + 35 mL of 8.4% NaHCO_3 (35 mmol) + 10 mL of 23% NaCl (40 mmol) + 2.1 mL of 10% $\text{CaCl}_2 \cdot 2\text{H}_2\text{O}$ (1.45 mmol or 2.9 mEq); total volume = 1.047 L.

Final concentrations in mM: Na, 145; Cl, 114; HCO_3^- , 33; and Ca, 1.35 (2.7 mEq/L).

2. **Two-bag method.** Bags of 0.9% saline with added calcium are alternated with bags of 0.45% saline with added bicarbonate.

Formulation: *Solution A:* 1.0 L of 0.9% saline + 4.1 mL of 10% $\text{CaCl}_2 \cdot 2\text{H}_2\text{O}$ (2.8 mmol or 5.6 mEq). *Solution B:* 1.0 L of 0.45% saline + 75 mL of 8.4% NaHCO_3 (75 mmol); total volume = 2.079 L.

Final concentrations in mM (when considered together): Na, 147; Cl, 114; HCO_3^- , 36; and Ca, 1.35 (2.7 mEq/L).

3. **Dialysis machine method (C-HD only).** One can prepare bicarbonate-containing dialysis solution for C-HD by ultrafiltering dialysis solution prepared by a standard dialysis machine across a dialyzer (to remove bacteria) and storing the solution in a 15-L sterile drainage bag from a peritoneal dialysis cycler. Such solutions should be used promptly after preparation. This technique has since been modified by storing solutions in more convenient 6-L sterile bags. The fluid preparation does not show growth of

bacteria for at least 72 hours and for up to 1 month in tests. Routinely, however, the bags are discarded if not used within 72 hours of preparation by protocol. In 10 years of use, there have been no reported adverse events, and *Limulus* amoebocyte lysate assays for endotoxin are reliably below the limit of detection (Teo, 2006).

- C. **Sterility.** Sterile dialysis solution is used for C-HD and C-HDF because the slow dialysate transit time plus the extended time of use of the same circuit and dialyzer could otherwise encourage bacterial growth in the dialysate circuit. All replacement fluid infusions given directly into the blood lines must be sterile.
- D. **Temperature of dialysis solution/replacement fluid.** CRRT can be set up so that dialysis solution and replacement fluid are infused at room temperature. This is a departure from conventional dialysis, where dialysis solution is warmed. Use of room temperature fluid results in heat subtraction from the patient; in fact, the hemodynamic benefits of CRRT appear to be due largely to such thermal cooling effects. When applied over long periods, CRRT-associated heat subtraction may mask the presence of fever, thus reducing the reliability of body temperature as a marker for infection or inflammation. Whether this heat subtraction has an effect on the body's ability to resist infection has not been studied. One study done in a septic shock model using sheep suggested that warming of blood in the extracorporeal circuit increased survival rate (Rogiers, 2006). Current CRRT delivery systems have heating systems. Heating sometimes is associated with an appearance of bubbles in the replacement or dialysis solutions, especially with bicarbonate formulations; the clinical importance of this effect remains to be determined.

VIII. PRESCRIBING AND DELIVERING CRRT

- A. **Dose versus outcome.** The suggested dose of CRRT in AKI is a delivered effluent volume of 20–25 mL/kg per hour (KDIGO AKI, 2012). This was, however, presented as an ungraded recommendation, and there is no evidence that lower levels of therapy give worse results. A handful of randomized controlled trials that suggested a use of a markedly higher effluent volume led to better outcomes, but these results were not confirmed. One mechanistic analysis has suggested that use of a higher effluent volume results in only a very small increase in middle-molecule clearance (Hofmann, 2010) and that the best way to increase middle-molecule removal is to increase blood flow and membrane surface area. There is no evidence that convective therapies (C-H or C-HDF) lead to better outcomes than diffusion-based treatments (C-HD). The adequate dose of CRRT remains an area where more research is needed.

To deliver an effluent volume of 20–25 mL/kg per hour, one normally would need to prescribe a lower inflow fluid rate, as the effluent volume will also include 2–5 L per day of excess fluid removed from the patient. However, technical problems often arise, yielding to interruption of therapy or reduction of efficiency due to partial clotting of the dialyzer, and so it is wise to prescribe a slightly higher inflow volume than the target. As noted above, when predilution mode is used, the infusion rate of the replacement fluid should be increased by about 15%–20%, depending on the ratio of predilution fluid infusion rate to blood flow. The dilution effect will be more pronounced for compounds removed from the plasma only, because then it will be proportional to the ratio of replacement fluid infusion

rate to plasma flow rate rather than the ratio of replacement fluid infusion rate to BFR.

- B. **Empiric dosing.** The intensity of treatment should be adjusted on the basis of clinical circumstances. CRRT intensity may need to be increased in highly catabolic patients, to facilitate nutritional support, in tumor lysis syndrome, or for drug intoxication where intermittent therapies are not tolerated. It may be helpful to consider adequate CRRT dosing by evaluating the daily serum urea nitrogen level while on treatment. Based on information from the RENAL study and ATN study, the average serum urea nitrogen achieved should be less than 45 mg/dL (16 mmol/L). A method of dosing to target a given level of blood urea nitrogen is given in Table 15.4. A simplified nomogram to target a given blood urea nitrogen level is given in Fig. 15.3.
- C. **Dosing for SLED and SLED-F.** Given the relative absence of dose-finding studies, there are no specific guidelines for the amount of SLED or SLED-F to give. The KDIGO AKI guidelines recommend that a weekly Kt/V of at least 3.9 be given when intermittent RRT (IRRT) is used, where the weekly Kt/V is defined simply as the sum of the treatments given each week. Usually, SLED is done for 6–12 hours, four to seven times per week, with a BFR of 200–300 mL/min and dialysis solution flow rate of 300–400 mL/min (Kumar, 2000). Such a prescription far exceeds the 3.9 “weekly Kt/V ” guideline recommended by KDIGO.

IX. **EQUIPMENT.** Many advanced machines are available to deliver various forms of CRRT. Some of them can also perform plasmapheresis, which is beyond the scope of this chapter. One cannot review them all, and the selection of devices described below should not be considered to be an endorsement of these devices over their competitors.

- A. **Prismaflex® System from Gambro (Lakewood, CO).** The Prismaflex System consists of five integrated pumps (blood, dialysate, effluent, substitution fluid, and preblood pump), and four pullout weighing devices with removable handles (for effluent, preblood pump, dialysate, and substitution fluid), which allow for fluid control with different variants of CRRT. The addition of the preblood pump allows for infusion of fluid in predilution mode or for continuous infusion of anticoagulant into the circuit. Simultaneous pre- and postfilter dilution can be performed by two integral pinch valves that control delivery of replacement fluid to the circuit. Different sources for dialysis and substitution fluids can be used. Control of ultrafiltration and net patient fluid removal is achieved using an integrated control panel with touch screen, which regulates the dialysate, effluent, preblood pump, and substitution fluid pump speeds. Other features include preconnected cartridge sets that include the filter, a programmable anticoagulant syringe, and optional blood warmer.
- B. **Use of modified “2008K” or “2008T” dialysis machines from Fresenius USA (Walnut Creek, CA).** C-HD can be done using standard dialysis equipment, but some standard dialysis machines need to be altered to permit delivery of a dialysis solution flow rate of 100 mL/min. Blood lines and dialyzers are replaced every 24 hours.

Solute equilibration between effluent and serum will decline with time owing to membrane clogging (Claire-Del Granado, 2011). Furthermore, urea kinetic modeling does not consider middle- or large-molecular-weight solute clearance, and the impact of the latter remains unclear.

1. Six steps to estimating the prescription

- a. Estimate or measure the patient's **urea generation rate**.
- b. Decide on the **desired level of SUN**.
- c. Calculate the **total urea clearance** necessary to keep the SUN at the desired level for the urea generation rate obtained from Step 1.
- d. Measure **residual renal urea clearance**. If desired, subtract this from the total urea clearance to obtain the **extracorporeal urea clearance** that will be required.
- e. Calculate the **required drainage fluid volume**. Set this equal to the required extracorporeal urea clearance, assuming 100% saturation. Exception: With predilution C-HF or with C-HD when using a dialysis solution inflow rate >2 L/hr, the urea saturation of the drainage fluid will be $<100\%$. In such cases, the required "drainage volume" should be increased appropriately (usually by 15–20%), on the basis of a measurement of percent saturation.
- f. Calculate the **required dialysis solution/replacement fluid inflow rate**. This is simply equal to the required drainage volume minus the **expected removal (L per day) of excess fluid**.

2. Sample problem: A **60-kg** male patient has a SUN of **40 mg/dL** (14 mmol/L) on day 1 and **65 mg/dL** (23 mmol/L) on day 2. A 24-hr urine collection from day 1 to day 2 contains **5 g** (178 mmol) of urea nitrogen. On day 2, weight has increased to **64 kg**. Estimated edema fluid is **8 L** on day 1 and is **12 L** on day 2. Calculate the clearance necessary to maintain the SUN at 40 mg/dL (14 mmol/L).

Solution:

a. Determine urea nitrogen generation rate.

1. Estimate initial and final total-body water.

Initial total-body water: Initial weight is 60 kg with 8 kg estimated edema fluid.

Edema-free weight is then 52 kg. Estimate total-body water as 55% of the "edema-free" weight.

Total-body water is therefore $8 \text{ L} + (0.55 \times 52) = 8 \text{ L} + 28.6 \text{ L} = \mathbf{36.6 \text{ L}}$.

Final total-body water: Final weight is 64 kg, or 4 kg higher, all of which is water, so final total-body water is $36.6 + 4 = \mathbf{40.6 \text{ L}}$.

2. Estimate initial and final total-body urea nitrogen.

i. Initial and final SUN levels are 40 mg/dL and 65 mg/dL, respectively (about 14 and 23 mmol/L).

ii. Total-body urea nitrogen at time 1 = $36.6 \text{ L} \times 0.40 \text{ g/L} = 14.6 \text{ g}$.

In SI units: Total-body urea at time 1 = $36.6 \text{ L} \times 14.3 \text{ mmol/L} = 523 \text{ mmol}$.

iii. Total-body urea nitrogen at time 2 = $40.6 \text{ L} \times 0.65 \text{ g/L} = 26.4 \text{ g}$.

In SI units: Total-body nitrogen at time 2 = $40.6 \times 23.2 \text{ mmol/L} = 942 \text{ mmol}$.

3. Calculate change in total-body urea nitrogen.

i. Change in total-body urea nitrogen content from time 1 to time 2 is $26.4 \text{ g} - 14.6 \text{ g} = 11.8 \text{ g}$ urea nitrogen (or, in SI units, $942 \text{ mmol} - 523 \text{ mmol} = 420 \text{ mmol}$).

- ii. This 11.75-g change in urea nitrogen now needs to be corrected to a daily basis. If time 1 and time 2 are 24 hr apart, then the change in body urea nitrogen content is ~11.75 g per day (420 mmol per day).
4. **Account for urinary losses.** Urinary urea nitrogen loss during the 24-hr observation period was measured to be 5 g per day (178 mmol per day).
 5. **Calculate urea nitrogen generation rate.** This is equal to $11.75 + 5 = 16.75$ g per day (or, in SI units, $420 + 178 = 598$ mmol per day).
- b. **Decide on a target SUN level.** As discussed above, let us say it should be 40 mg/dL (14.3 mmol/L).
- c. **Calculate desired total clearance.** Assume target SUN = 40 mg/dL = 0.40 g/L.
 Urea N removal = clearance (K_D) \times serum level = $K_D \times 0.40$ g/L.
- At steady state, urea generation = removal, $16.75 = K_D \times 0.40$.
- $K_D = (16.75 \text{ g per day}) / (0.40 \text{ g/L}) = \mathbf{42 \text{ L per day}}$.
- In SI units: Assume target serum urea = 14.3 mmol/L.
- Urea N removal = clearance (K_D) \times serum level = $K_D \times 14.3$ mmol/L.
- At steady state, urea generation = removal, $598 = K_D \times 14.3$.
- $K_D = (598 \text{ mmol per day}) / (14.3 \text{ mmol/L}) = \mathbf{42 \text{ L per day}}$.
- d. **Adjust for residual renal function.** This patient actually had a urea clearance of about 10 L per day (about 7 mL/min), so we can subtract this from the required total clearance. Therefore, the required extracorporeal clearance is 32 L per day.
 - e. **Determine dialysis solution inflow rate.** This should be 32 L per day (assuming 100% saturation) minus the volume of excess fluid removal. For example, if we need to remove 3 L of fluid per day to offset hyperalimentation and fluid given with medications, subtract 3 L from 32 L in the example to obtain a required dialysate inflow rate of 29 L per day. We usually ignore residual renal function, because this may be ephemeral, and so we would add back the 10 L per day and use a dialysis solution inflow rate of 39 L per day.

- C. **Use of upgraded “2008 H/K” dialysis machines from Fresenius USA (Walnut Creek, CA).** Further advancements have been introduced to allow C-HD to become an integrated treatment option without any machine alteration. The machine may be calibrated to run at dialysate flows as low as 100–200 mL/min, but this option must be selected in service mode, and additional calibration is required. Ultrafiltration or variable sodium profiles are not available, and there is no ultrafiltrate time or target goal to set. The extracorporeal circuit, including dialyzer, should be replaced every 48 hours per manufacturer’s recommendations. These machines are also popular to deliver SLED, where more conventional blood and dialysate flow rates are used.
- D. **NxStage System One from NxStage Medical Inc. (Lawrence, MA).** The NxStage System One is a modular system that consists of a touch screen display, cyclor with user interface, stand with IV pole, and optional fluid warmer. It can be used both as a portable hemodialysis

machine and for CRRT therapies. The drop-in, single-use cartridge design, with or without a preattached filter, allows for a range of therapies and minimizes cyclor maintenance and disinfection requirements. The cartridge has volume chambers for volumetric balancing, thus eliminating the need for scales, and discharges effluent directly to drain. One special feature is the absence of a blood–air interface in the cartridge; this is designed to optimize blood flow and reduce clotting.

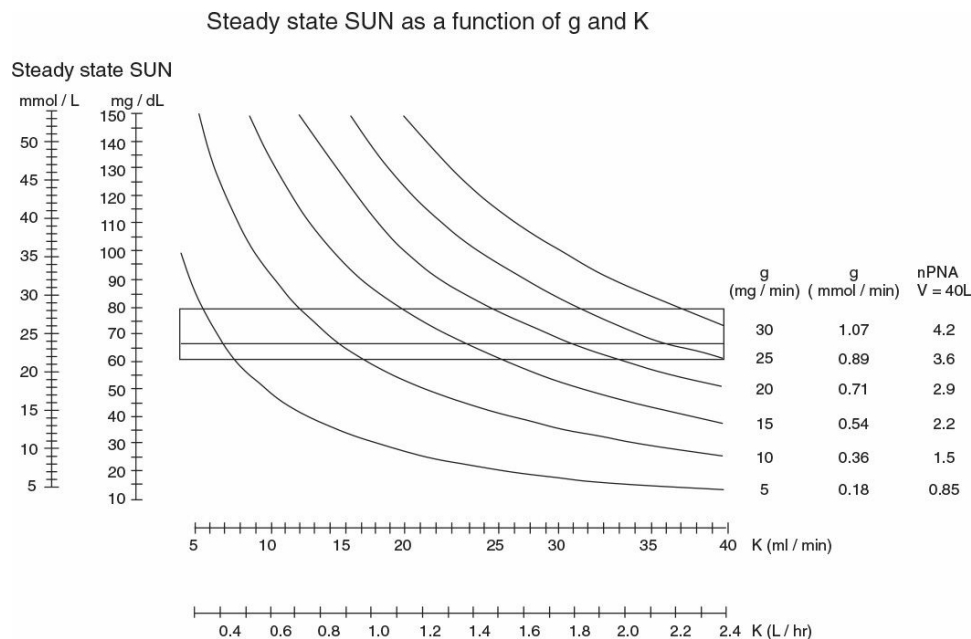

FIGURE 15.3 Estimated total extracorporeal urea clearance required to attain various steady-state serum levels of urea nitrogen. Clearance, on the bottom, is read from the intersection of the urea nitrogen generation level (g) and the steady-state goal serum urea nitrogen. (From Garred LJ. *Syllabus of the Second International Conference on CRRT*, San Diego, CA, Feb 9, 1997, p. 7.)

E. **Braun Diapact from B. Braun Medical Inc. (Bethlehem, PA).** The Diapact CRRT system is a simple and compact dialysis unit originally designed for use in emergency situations where a purified water supply was not available. It operates on a three-pump system (blood, dialysis/infusion solution, ultrafiltration) and an electronic single weighing cell. This machine also features a simplified user interface, an integrated fluid plate warmer, and choice of dialyzer capabilities. Flexible treatment options other than CRRT include IHD and hemofiltration.

X. **ANTICOAGULATION.** In most patients at low risk of bleeding, systemic heparin is routinely used as it is inexpensive and easy to implement. A patient already on systemic therapeutic anticoagulation for another indication (e.g., intra-aortic balloon pump) would not require additional anticoagulation. Patients with severe thrombocytopenia or impaired coagulation should have a trial of anticoagulation-free CRRT. In immediate postoperative patients or patients at high risk of bleeding, heparin-free CRRT or RCA can be used. In patients with nonimmune heparin-induced thrombocytopenia (HIT type I), RCA may be employed. Systemic anticoagulation therapy is often required in patients with immune-mediated HIT type II, a disorder that is associated with venous or arterial thrombosis in addition to the

thrombocytopenia. In such patients who also require CRRT, use of systemic anticoagulation with lepirudin or argatroban has been described.

- A. **Heparin.** After attachment of the primed hemofilter or dialyzer, if baseline clotting times are not elevated, 2,000–5,000 units of heparin are injected into the patient, ideally via the venous (outflow) blood line. One should then wait for 2–3 minutes to allow the heparin to mix with the patient’s blood. Next, a constant infusion of heparin (at a rate of 500–1,000 units/hour) is begun via an intravenous infusion pump emptying into the arterial (inflow) blood line, and blood flow through the extracorporeal circuit is begun. Heparin therapy is monitored as per Table 15.5.
- B. **Heparin-free method.** In patients with liver disease, in postoperative patients, in patients with active or recent bleeding, or in patients with HIT, CRRT can be performed without heparin. The filter will clot periodically and will need to be changed at more frequent intervals. If acute bleeding occurs while CRRT with heparin is being performed, the procedure can be continued even after heparin administration has been stopped. When heparin is not given, several steps may be taken to reduce the likelihood of clotting.
 1. With C-HD, the dialysis solution inflow rate is increased by 20–40%. The higher dialysate flow rate will compensate for the anticipated loss of clearance as the unheparinized dialyzer slowly clots. When using the heparin-free method for C-HD, we usually do not infuse saline into the arterial blood line on a periodic basis, in contrast to what is commonly practiced in the case of heparin-free IHD for fear of introducing microbubbles into the filter, which may lead to clot formation.

TABLE

15.5

Heparin Protocol for Continuous Therapies

1. **Initial therapy:** Heparin in priming and rinsing solution as described in text. At start of procedure, give 2,000–5,000 IU heparin to the patient via the venous line or other access. Wait 2–3 min for the heparin to mix with the circulation. Then start 500–1,000 IU/hr constant heparin infusion into the arterial (inlet) blood line.
2. **Monitoring:** PTT measured at the arterial and venous blood lines every 6 hr.
 - Maintain arterial PTT 40–45 s.
 - Maintain venous PTT >65 s.
 - If arterial PTT >45 s, decrease heparin by 100 IU/hr.
 - If venous PTT <65 s, increase heparin by 100 IU/hr, but only if arterial PTT <45 s.
 - If arterial PTT <40 s, increase heparin by 200 IU/hr.

PTT, partial thromboplastin time.

2. In C-HF done without heparin, the predilution mode is preferred because prefilter fluid replacement reduces the hemoconcentration within the hemofilter when plasma water is removed. Keeping the blood flows at 200 mL/min or higher may also prevent early or excessive clotting.

When heparin is not used in patients without coagulation disturbances, the

dialyzers will usually clot within 8 hours. A sign of early clotting is a reduction to <0.8 in the ratio of dialysate to serum urea nitrogen levels. When the ratio is <0.6 , clotting is imminent.

- C. **Regional citrate anticoagulation.** Citrate chelates calcium (and magnesium) and impedes the coagulation cascade. Calcium citrate complexes are removed in the effluent and those that return to the circulation are metabolized by the liver and skeletal muscles. RCA may reduce bleeding risk in comparison with heparin for CRRT (Wu, 2012), with similar or better efficacy on circuit patency depending on the citrate dose administered (Monchi, 2004). Citrate anticoagulation, by reducing local ionized calcium concentration, may also reduce neutrophil and complement activation in the extracorporeal circuit (Schilder, 2014). For patients who have no contraindications to use of citrate, the KDIGO 2012 AKI guidelines recommend use of RCA for CRRT.

On average, 3 mmol of citrate per liter of blood circulated is required to suppress the postfilter plasma ionized calcium to 0.3–0.4 mmol/L, the level needed for effective circuit anticoagulation. Calcium and magnesium losses are replaced by systemic infusions according to strict protocols. Toxicity is determined by the total citrate load and is exacerbated in patients with liver dysfunction and multiorgan failure; in such patients, the amount of citrate infused can overwhelm the patient's ability to metabolize it, causing accumulation of calcium citrate complexes and inadequate regeneration of free calcium. This in turn can lead to high anion gap metabolic acidosis (citrate) and a high (>2.5) ratio of total calcium to ionized calcium (Meier-Kriesche, 2001), findings that require cessation of RCA and correction of hypocalcemia.

ACD-A solution (anticoagulant citrate dextrose form A) containing 3% trisodium citrate (2.2 g/mL per 100 mL), citric acid (0.73 g/mL per 100 mL), and dextrose (2.45 g/mL per 100 mL) (Baxter-Fenwal Healthcare Corp., Deerfield, IL) is preferred over trisodium citrate for routine RCA, as ACD-A is commercially prepared and is less hypertonic, reducing the potential for mixing errors and dangers of overinfusion. Many RCA protocols have been described for CRRT. The major complications of RCA are symptomatic reductions in serum ionized calcium levels and metabolic alkalosis from citrate metabolism.

We prefer RCA methods that minimize the amount of citrate infused, and these typically use calcium-free dialysis or replacement fluids, because the citrate infusion needs only to counteract the calcium in the patient's blood. However, methods of RCA have been reported where calcium is maintained in the replacement fluid or the dialysis solution (Mitchell, 2003). These have an advantage of avoiding the return of a low-ionized calcium infusate close to the heart in the event that the calcium replacement solution pump fails.

1. **Swartz protocol** (Fig. 15.4). As an example, here is a procedure for RCA in C-HD according to Swartz (2004).
 - a. Attach the ACD-A 1,000-mL bag to an infusion pump infusing into the arterial line closest to the patient. A negative pressure valve is inserted into this line so that the infusion will occur in the direction of the blood pump and not directly into the patient should the blood pump stop. The rate of infusion in milliliters per hour is initially at 1.5 times the BFR in milliliters per minute. For example, when the BFR

is set at 200 mL/min, the citrate rate will then be 300 mL/hour.

- b. A calcium chloride infusion (20 mg/mL in normal saline) is infused via a three-way stopcock valve placed at the venous port of the dialysis catheter. Calcium gluconate infusion may also be given via a peripheral vein catheter, but this will result in higher fluid volumes. The initial calcium infusion rate should be set at 10% of the ACD-A infusion rate. For example, if the ACD-A rate is 300 mL/hour, then the calcium infusion rate is 30 mL/hour.

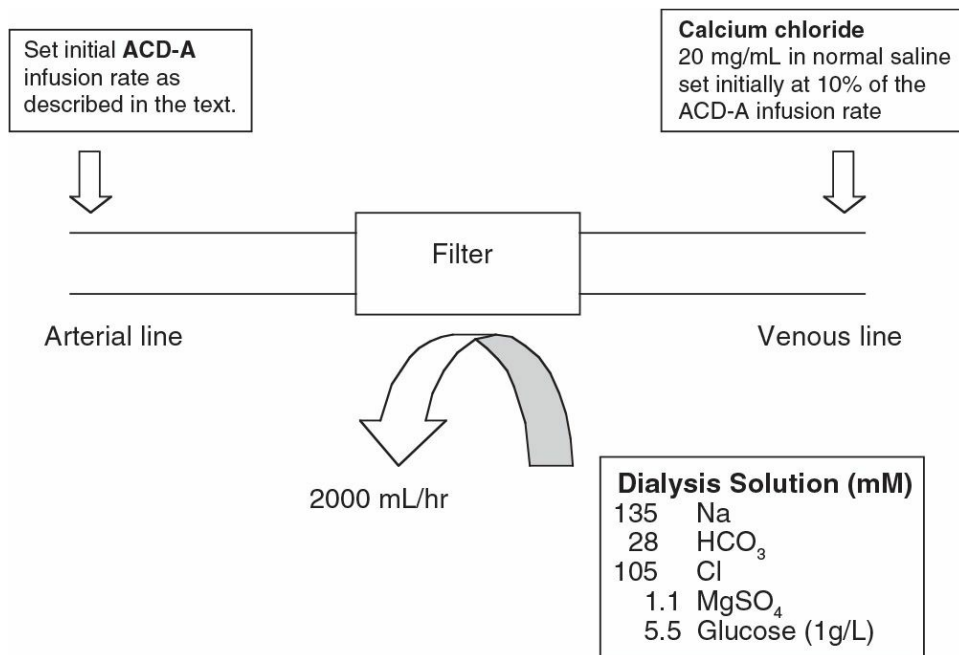

FIGURE 15.4 Circuit diagram for citrate slow continuous hemodialysis. The MgSO₄ level has been modified to 1.1 mM (vs. 1.3 mM as originally depicted in the Swartz publication). (From Swartz R, et al. Improving the delivery of continuous renal replacement therapy using regional citrate anticoagulation. *Clin Nephrol.* 2004;61:134–143.)

- c. Ionized calcium is sampled every 2 hours \times 4, then every 4 hours \times 4 for the first 24 hours, then every 6–8 hours thereafter. The ionized calcium should be checked within 1–2 hours whenever the site of the infusion or tubing is changed. The ionized calcium samples should be drawn from two sites and labeled carefully, one being “postfilter” from the postfilter venous sample port and the other from the patient via a systemic arterial or a venous line. Basic chemistries and total calcium should be checked every 6–8 hours. The titration of ACD-A citrate and calcium chloride infusions are done according to Table 15.6.
- d. The dialysis solution with this method is calcium free and contains sodium 135 mM, magnesium (in the form of magnesium sulfate) 1.1 mM (2.2 mEq/L), bicarbonate 28 mM, chloride 105 mM, sulfate 1.1 mM, and glucose 5.5 mM (1 g/L). The lower concentrations of sodium and bicarbonate help to counteract the tonicity and bicarbonate delivery from the infusion of ACD-A. Dialysis solution flow rate is 2.0 L/hour. Note: The dialysis solution magnesium concentration (1.1 mM) in the method shown is higher than that of most other available solutions (0.5–0.75 mM, Table 15.3).

- D. **Regional citrate protocols for SLED.** A number of these have been described, including that by Fiaccadori (2013), as well as an automated system by Szamosfalvi (2010); the latter group is also working on sensors to measure citrate and ionized calcium levels (Yang, 2011).
- E. **Anticoagulation with lepirudin and argatroban.** See Table 15.7 for dosing parameters. **Lepirudin** (recombinant hirudin) and argatroban are direct thrombin inhibitors. Lepirudin is eliminated mainly by the kidneys. The dose has to be adjusted according to residual renal clearance and dialysis clearance. It can be administered as a continuous infusion or as repetitive boluses. Typical doses are 0.005–0.025 mg/kg body weight per hour. The anticoagulation effect is monitored by measuring the activated partial thromboplastin time (aPTT), aiming to keep it about 1.5–2.0 times normal, thereby ensuring anticoagulation without an excess of bleeding complications. After more than 5 days of lepirudin use, antilepirudin antibodies may develop. These antibodies enhance the anticoagulation effects of lepirudin, and a reduction of the infusion dose may be needed to minimize bleeding risk. It is recommended that with prolonged use of lepirudin, daily aPTT measurements be taken. **Argatroban** is eliminated predominantly by liver metabolism and biliary secretion, and for this reason may be a preferred agent in renal failure patients. Argatroban infusion is initiated at 0.5–1.0 mcg/kg/min, using lower doses in patients with hepatic dysfunction. The anticoagulation effect is also monitored by measuring aPTT. The administration of fresh frozen plasma is required to reverse bleeding due to overdosage of lepirudin or argatroban. Hemofiltration with high-flux dialyzers can reduce the plasma concentration of hirudin.

TABLE

15.6

ACD-A Citrate and Calcium Titration Guidelines (for Swartz RCA Protocol)

Postfilter Ionized Calcium (mM)	Adjustment of ACD-A Rate
<0.20	Reduce rate by 5 mL/hr.
0.20–0.40	No adjustment.
0.40–0.50	Increase rate by 5 mL/hr.
>0.50	Increase rate by 10 mL/hr.
Calcium chloride infusion is titrated to systemic ionized calcium level.	
Systemic Ionized Calcium (mmol/L)	
Adjustment of Calcium Infusion	
>1.45	Reduce rate by 10 mL/hr.
1.21–1.45	Reduce rate by 5 mL/hr.
1.01–1.20	No adjustment.
0.90–1.00	Increase rate by 5 mL/hr.
<0.90	10 mg/kg calcium chloride bolus; increase rate by 10 mL/hr.

ACD-A, anticoagulant citrate dextrose form A.

TABLE

Dosing Parameters for Continuous Renal Replacement Therapy with Lepirudin or Argatroban

	Lepirudin	Argatroban
Infusion rate	Initiate at 0.005–0.01 mg/kg/hr	Initiate at 0.5–1.0 mcg/kg/min; start at lower doses in patients with hepatic dysfunction.
Monitoring test	aPTT	aPTT
Target	1.5–2.0 times normal	1.5–2.0 times normal

aPTT, activated partial thromboplastin time.

F. **Other anticoagulants.**

1. **Low-molecular-weight heparins:** Sagedal and Hartmann (2004) reviewed the use of low-molecular-weight heparins (LMWHs) in CRRT. Monitoring anticoagulation requires measuring anti-factor Xa activity, but use of this measurement to guide LMWH heparin use in CRRT remains to be defined. LMWH is not readily reversible with protamine. In C-HDF, **dalteparin** can be given as a bolus of about 20 U/kg followed by an infusion of 10 U/kg per hour for adequate anticoagulation without an excess of bleeding. In a study of C-HD, a dalteparin dose of 35 U/kg bolus followed by 13 U/kg per hour resulted in good filter patency rates, but there were bleeding episodes. At a lower dalteparin dose of 8 U/kg bolus and infusion of 5 U/kg per hour, circuit life was poor, so perhaps the optimal dose is somewhere in between. **Enoxaparin** and **nadroparin** may be used, but the experience is limited. Nadroparin was compared with RCA for C-H; in patients who weighed >100 kg, nadroparin was given as a 3,800 IU bolus followed by continuous infusion at a rate of 456 IU/hour. In patients ≤100 kg, the nadroparin dose was a 2,850 IU bolus followed by a 380 IU/hour infusion. This was done without anti-Xa monitoring. Patients in the nadroparin arm suffered more bleeding complications than those treated with RCA (Oudemans-van Straaten, 2009).
 2. **Nafamostat mesylate** is a synthetic serine protease inhibitor and prostacyclin analog with minimal hypotensive activity. Its use in CRRT has been associated with improved circuit life and relatively low bleeding risk. The starting dose was a continuous infusion of nafamostat solution (200 mg of nafamostat mixed with 20 mL of 5% dextrose solution) at a rate of 10 mg/hour. A bedside ACT test was used to monitor circuit coagulation, and the infusion rate was adjusted as necessary (Baek, 2012).
- G. **Microbubbles.** Microbubbles can be introduced into the extracorporeal circuit during priming and any time a connection is made or reset upstream to the filter. The microbubbles can get into the hollow fibers, and this can lead to clotting of the filter. Care should be taken to minimize this problem during priming and infusions.
- H. **Signs of filter clotting.** Signs of markedly reduced blood flow include darkening of the blood in the extracorporeal circuit, coolness of blood in the venous blood line, and separation of erythrocytes and plasma in the extracorporeal circuit. Saline infusion can help diagnose a near-clotted system: This can make clots in transparent parts of the hemofilter visible.

When using C-HD, one can check the filtrate urea nitrogen (FUN):SUN ratio. If it is <0.6, clotting is imminent. An ultrasound method has been used to measure filter fiber bundle volume (FBV) during use, but online FBV measurements have not been found to predict filter longevity. One problem is that the majority of clotting seems to occur in the

venous air trap chamber rather than in the dialyzer itself (Liangos, 2002).

XI. VITAMINS AND MINERALS. Total amino acids are removed in the amount of 12 g per 24 hours at effluent flow rates of 1 L/hour and when standard parenteral nutrition solutions are infused at a rate of 60–100 mL/hour. Water-soluble vitamins and trace elements are easily removed on CRRT. If prolonged therapy is expected, supplementation is recommended; administration of active vitamin D, vitamin E, vitamin C, zinc, selenium, copper, manganese, chromium, and thiamine should be considered.

XII. PRINCIPLES OF DRUG REMOVAL BY CRRT. Drug clearance by CRRT is dependent on (a) drug properties such as MW, extent of protein binding, volume of distribution, and proportion of drug renally eliminated, (b) patient characteristics such as residual renal function, volume status, serum albumin concentration, and function of other organs involved in drug metabolism/excretion (e.g., liver), and (c) CRRT parameters (e.g., dialysate/ultrafiltration/blood/effluent rate, hemofilter size). Both C-HD and C-HF remove small solutes effectively, but C-HF is superior at removing middle- and large-MW drugs because of convection. In general, C-HF is considered to have higher drug clearance than C-HD at the same effluent flow rate, that is, $CVVH > CVVHDF > CVVHD$ (Churchwell, 2009).

The different intensities of CRRT treatments and the level of patient residual kidney function can result in marked variability in drug removal. Literature available on drug dosing in patients being treated by CRRT should be used only as a guide, realizing that they may not be applicable to the particular CRRT prescriptions being used in a given patient. One way of determining drug dosing in patients receiving CRRT is to estimate the total creatinine clearance (CrCl) on the basis of a patient's residual renal function and the expected creatinine clearance due to CRRT (Matzke, 2011). The CRRT procedure can be thought of as an extra kidney, the glomerular filtrate rate (GFR) of which will depend on the total effluent volume. Each 10 L per day of effluent volume is equivalent to about 7 mL/min of GFR ($7.0 \text{ mL/min} \times 1,440 \text{ minutes per day} = 10.08 \text{ L per day}$). Thus, when prescribing drugs to otherwise anuric patients receiving CRRT, one should write the drug dose as for a patient with a GFR of 7 mL/min for every 10 L of effluent volume.

Table 15.8 lists the approximate dosages for antibiotics in renal failure patients being treated with C-HD and C-HDF. Whenever possible, therapeutic drug monitoring (TDM) should be performed for antibiotics such as vancomycin, aminoglycosides, and other drugs that have a narrow therapeutic index. Any change to the CRRT prescription or clinical status (e.g., worsening or improvement in renal function) may require additional monitoring and dosage adjustment.

The amount of pressor drugs removed during CRRT is usually not a clinical issue, as pressor infusion rates are usually titrated to maintain a desired hemodynamic response. Table 15.9 gives doses of additional drugs commonly used in ICU patients with information on dose adjustment during CRRT.

XIII. ISOLATED ULTRAFILTRATION AND SLOW CONTINUOUS ULTRAFILTRATION (SCUF). Isolated ultrafiltration (IU) is achieved using standard dialysis equipment by simply putting the dialysate

in bypass, and can be performed prior to dialysis, after dialysis, or independently of dialysis. In patients with renal failure, IU is most often performed just prior to hemodialysis. SCUF is achieved using the same circuitry as for C-HD (Fig. 15.1) but omitting dialysis solution.

TABLE

15.8

Dosing of Antimicrobials in CRRT

Drug	LD	CVVH	CVVHD or CVVHDF
Acyclovir ^{a, b, c} (IV)	None	5–10 mg/kg q24 hr	HSV: 5–7.5 mg/kg q24 hr HSV encephalitis/ zoster: 7.5–10 mg/kg q12 hr
Amikacin ^{a, d}	10 mg/kg	7.5 mg/kg q24–48 hr	Same
Ampicillin (IV)	2 g	1–2 g q8–12 hr	1–2 g q6–8 hr Meningitis/ endocarditis: 2 g q6 hr
Ampicillin-sulbactam	3 g	1.5–3 g q8–12 hr	1.5–3 g q6–8 hr
Azithromycin (IV/PO)	None	250–500 mg q24 hr	250–500 mg q24 hr
Aztreonam	2 g	1–2 g q12 hr	1 g q8 hr or 2 g q12 hr
Cefazolin	2 g	1–2 g q12 hr	1 g q8 hr or 2 g q12 hr
Cefepime	2 g	1–2 g q12 hr	General: 1 g q8 hr Severe: 2 g q12 hr
Cefotaxime	None	1–2 g q8–12 hr	1–2 g q8 hr
Ceftazidime	2 g	1–2 g q12 hr	1 g q8 hr or 2 g q12 hr
Ceftriaxone	2 g	1–2 g q24 hr	Same
		Meningitis, <i>Enterococcus faecalis</i> endocarditis: 2 g q12 hr	
Ciprofloxacin (IV)	None	200–400 mg q12–24 hr	400 mg q12–24hr
Ciprofloxacin (PO)	None	500 mg q12–24 hr	
Clindamycin (IV)	None	600–900 mg q8 hr	Same
Clindamycin (PO)	None	150–450 mg q6 hr	Same
Colistin ^{b, c} (IV)	None	2.5 mg/kg q24–48 hr	2.5 mg/kg q12–24 hr
Daptomycin ^e	None	4–6 mg/kg q48 hr	4–8 mg/kg q48 hr
Fluconazole ^a (IV/PO)	400–800 mg	200–400 mg q24 hr	400–800 mg q24 hr
Ganciclovir IV ^a	2.5 mg/kg	1.25 mg/kg q24 hr	LD for all then 2.5 mg/kg q12–24 hr (induction) 2.5 mg/kg q24 hr (maintenance)
Gentamicin	2–3 mg/kg		
• Mild UTI or synergy		• 1 mg/kg q24–36 hr then per level	• Same
• Mod–severe UTI		• 1–1.5 mg/kg q24–36 hr then per level	• Same
• GNR infection		• 1.5–2.5 mg/kg q24–48 hr then per level	• Same
Imipenem-cilastatin	1 g	250 mg q6 hr or 500 mg q8 hr	500 mg q8 hr Severe: 500 mg q6 hr
Levofloxacin (IV/PO)	500–750 mg	250 mg q24 hr	LD then 250–750 mg q24 hr

Linezolid (IV/PO)	None	600 mg q12 hr	Same
Meropenem	1 g	500 mg q8 hr or 1 g q12 hr	500 mg q6–8 hr or 1 g q8–12 hr Severe/CF/CNS: 2 g q12 hr 500 mg q6–8 hr
Metronidazole (IV/PO)	None	500 mg q6–12 hr	500 mg q6–8 hr
Moxifloxacin (IV/PO)	None	400 mg q24 hr	Same
Nafcillin	None	2 g q4–6 hr	2 g q4 hr Mild infections: 1 g q4 hr
Penicillin G (IV)	4 MU	2 MU q4–6 hr	LD then 2–4 MU q4–6 hr
Piperacillin-tazobactam	None	2.25–3.375 g q6–8 hr	3.375 g q6 hr or extended infusion: 3.375 g q8 hr (infused over 4 hr)
Rifampin (IV/PO)	None	300–600 mg q12–24 hr	Same
Ticarcillin-clavulanate	3.1 g	2 g q6–8 hr	Same 3.1 g q6 hr
Tigecycline	100 mg	50 mg q12 hr	Same
Tobramycin ^{a, e}	2–3 mg/kg		
• Mild UTI or synergy		• 1 mg/kg q24–36 hr then per level	• Same
• Mod–severe UTI		• 1–1.5 mg/kg q24–36 hr then per level	• Same
• GNR infection		• 1.5–2.5 mg/kg q24–48 hr then per level	• Same
TMP-SMX ^{a, e} (IV/PO)	None	2.5–7.5 mg/kg (TMP) q12 hr	2.5–5 mg/kg (TMP) q12 hr PCP/ <i>Stenotrophomonas</i> : 5–7.5 mg/kg (TMP) q12 hr
Vancomycin ^f (IV)	15–25 mg/kg	10–15 mg/kg q24–48 hr or 1 g q24 hr	LD then 10–15 mg/kg q24 hr
Voriconazole ^g (PO)	400 mg q12 hr × 2	200 mg q12 hr	Same

CAP, community-acquired pneumonia; CF, cystic fibrosis; CNS, central nervous system; CVWH, continuous venovenous hemofiltration; CVVHD/CVVHDF, continuous venovenous hemodialysis, continuous venovenous hemodiafiltration; HSV, herpes simplex virus; ICU, intensive care unit; IV, intravenous; LD, loading dose; MD, maintenance dose; MU, million units; PCP, *Pneumocystis carinii* pneumonia; PO, oral; TMP, trimethoprim; SMX, sulfamethoxazole.

^a Based on dialysate flow/ultrafiltration rates of 1–2 L/hr and minimal residual renal function.

^b Use IBW (kg); ideal body weight IBW (male) = 50 kg + (2.3 × height in inches >60 inches), IBW (female) = 45 kg + (2.3 × height in inches >60 inches).

^c Use IBW (kg) in obese.

^d Use adjusted BW (kg) in morbidly obese; adjusted body weight ABW (kg) = IBW + 0.4 (TBW – IBW).

^e Use adjusted BW (kg) in obese.

^f Use actual body weight (kg).

Data from: Aoki FY, Allen UD, Stiver HG, et al, AMMI Canada Guidelines, “The Use of Antiviral Drugs for Influenza: Guidance for Practitioners 2012/2013,” *Can J Infect Dis Med Microbiol*, 2012, 23(4):e79-92;

Facts and Comparisons: Available from <http://online.factsandcomparisons.com>. Accessed April 23, 2013; Heintz BH, Matzke GR, Dager WE. Antimicrobial dosing concepts and recommendations for critically ill adult patients receiving continuous renal replacement therapy or intermittent hemodialysis. *Pharmacotherapy*. 2009;29:562–77;

Trotman RL, Williamson JC, Shoemaker DM, et al. Antibiotic dosing in critically ill adult patients receiving continuous renal replacement therapy. *Clin Infect Dis*. 2005;41:1159–1166.

Up to date: Available from <http://www.uptodate.com/contents/search>. Accessed April 23, 2013.

Stanford Hospital & Clinics Antimicrobial Dosing Reference Guide 2013. Available at <http://bugsanddrugs.stanford.edu/documents/2013SHCABXDosingGuide.pdf>. Accessed April 10, 2014.

Lexi-Drug, Lexi-Comp [Internet database]. Hudson, OH: Lexi-Comp, Inc. Available at <http://www.crlonline.com>. Accessed April 10, 2014.

A. **Isolated ultrafiltration.** IU is usually carried out when IHD is being given. IU is useful to remove additional fluid while avoiding disequilibrium syndrome for the initial one or two

dialysis treatments in acutely uremic patients. It is also used in some outpatient dialysis units in patients with difficulty in fluid removal. The principal advantage of IU is that fluid removal is better tolerated than with conventional hemodialysis. Today, IU may no longer be a superior method of fluid removal. Historically, poor tolerance to fluid removal during IHD was due partly to use of acetate-containing dialysis solution, to use of excessively warmed dialysis solution, and to use of solutions containing an inappropriately low-sodium concentration (e.g., 5–10 mM below that of plasma). If these factors are avoided (i.e., if a bicarbonate-containing, high-sodium, slightly cooled dialysis solution is used), then the superiority of IU in terms of hemodynamic stability is no longer demonstrable. Waste product removal is minimal during IU. For this reason, the subsequent hemodialysis session length should not be shortened, and thus the total treatment time for the separated IU–hemodialysis combination must be prolonged.

Despite the relatively good tolerance to fluid removal with IU, hypotension can still occur if the ultrafiltration rate is excessive. If overt edema is present, then hypotension is rare at ultrafiltration rates of up to 1.5 L/hour, but one should not go higher unless one is monitoring blood volume status using a hematocrit sensor. A rebound hyperkalemia has been reported after intensive IU, perhaps due to exit of intracellular potassium into the extracellular fluid. Although the existence of this complication is controversial, any possible hyperkalemia with IU can best be avoided by routinely following IU with a period of hemodialysis.

TABLE

15.9

Recommended Adult Dosages of Some Common Drugs Used in the ICU

Drug	Indication	Normal Dose	CRRT Dose Based on CrCl (mL/min)	
			10–30	30–50
Amiodarone	Atrial fibrillation	5–7 mg/kg over 30–60 min, then 1.2–1.8 g per day continuous infusion or in divided oral doses until 10 g total.	Same	Same
Digoxin	Atrial fibrillation in patients with heart failure	Loading dose (LD): 0.25 mg q2 hr, up to 1.5 mg within 24 hr. Maintenance dose (MD): 0.125–0.375 mg once daily.	LD: reduce dose by 50%MD: Administer 25–75% of dose or q36 hr.	MD: Administer 25–75% of dose or q36 hr.
Haloperidol	Delirium in ICU	Initial: 2–10 mg depending on degree of agitation; if inadequate, may repeat bolus dose (with sequential doubling of initial bolus dose) q15–30 min until calm achieved; then administer 25% of last bolus dose q6 hr.	Same (monitor ECG and QTc interval)	Same (monitor ECG and QTc interval)
Lorazepam	Status epilepticus Agitation in ICU	4 mg per dose (given as slow IV, max rate: 2 mg/min); may repeat in 10–15 min; usual max dose: 8 mg; 0.02–0.06 mg/kg q2–6 h or 0.01–0.1 mg/kg/hr; Reduce dose by 50% if used with probenecid or valproic acid.	Same (risk of propylene glycol toxicity; monitor closely if using for prolonged periods or at high doses)	Same (risk of propylene glycol toxicity; monitor closely if using for prolonged periods or at high doses)
Phenytoin	Status epilepticus	LD: 10–20 mg/kg at max rate of 50 mg/min. MD: 100 mg q6–8 hr.	Same. Titrate dose according to response, and perform TDM to maintain free phenytoin conc 1–2.5 mcg/mL.	Same. Titrate dose according to response, and perform TDM to maintain free phenytoin conc 1–2.5 mcg/mL.
Phenobarbital	Anticonvulsant/ status epilepticus	LD: 10–20 mg/kg (max rate: ≤ 60 mg/min in patients ≥60 kg); may repeat dose in 20-min intervals as needed (max total dose: 30 mg/kg). MD: 1–3 mg/kg per day in divided doses or 50–100 mg 2–3 times per day.	Same	Same
Theophylline	COPD (acute symptoms)	LD: 4.6 mg/kg (if theophylline naïve within last 24 hr); if theophylline had been administered in past 24 hr, no loading dose recommended before checking serum drug concentration. MD: Adults 16–60 yr: 0.4 mg/kg/hr (max 900 mg per day); adults >60 yr: 0.3 mg/kg/hr (max 400 mg per day).	Perform TDM to maintain serum theophylline conc 5–15 mcg/mL.	Perform TDM to maintain serum theophylline conc 5–15 mcg/mL.

All dosages above are for intravenous administration and assume CRRT clearance of 25 mL/kg/hr of effluent where each 10 L per day of ultrafiltrate volume is equivalent to 7 mL/min of GFR (i.e., for a 50- to 70-kg patient, estimated GFR is 20–30 mL/min). Dosing ranges are provided to accommodate for differences in UF and dialysis flow rates, and residual renal function of patient.

B. **SCUF.** SCUF is used primarily in an ICU setting to remove excess fluid from patients in whom residual renal function is substantial, and in whom electrolyte and acid–base imbalances are not an issue. SCUF is also used in inpatient treatment of patients with refractory heart failure and mildly impaired renal function, as described below. A disadvantage of SCUF is that acid–base disturbances and electrolyte imbalances need to be corrected by nondialytic means.

1. **SCUF for congestive heart failure.** Patients with congestive heart failure may develop concomitant renal failure, resulting in fluid overload. They may have anuria, oliguria, or insufficient urine output (<1 L per day) despite optimal medical treatment with maximal doses of intravenous diuretics, inotropes, and natriuretic peptides. Ultrafiltration is a treatment option in such situations. While inpatient and outpatient intermittent IU for C-HF have been described, there are several advantages of SCUF that should be considered. Slow removal of fluid results in less hemodynamic issues, such as symptomatic hypotension. Also, many of these patients are volume-overloaded substantially, sometimes 10–15 kg over their “feel good” weight; continuous therapy allows for larger volumes of fluid to be removed while minimizing the hemodynamic problems. Ultrafiltration techniques can be further enhanced by using a Swan–Ganz catheter for central volume monitoring, thereby guiding the end point of treatment, and by using an online blood volume monitoring instrument to protect against an excessive ultrafiltration rate. Small, portable machines designed specifically for SCUF have become available. However, a large randomized trial of stepped pharmacologic treatment versus ultrafiltration for patients hospitalized for acute decompensated heart failure and worsened renal function found that the pharmacologic approach resulted in better preservation of kidney function at 96 hours after start of treatment (Bart, 2012).

XIV. INTERMITTENT HEMODIAFILTRATION. THIS IS DESCRIBED IN Chapter 17.

XV. CRRT POINTERS FOR CERTAIN GROUPS OF PATIENTS

A. **Brain edema.** In critically ill patients with acute renal failure, CRRT has been shown to cause fewer changes in terms of brain edema when compared with IHD. KDIGO 2012 AKI guidelines specifically recommend use of CRRT in place of conventional IHD in patients with evidence of brain edema or increased intracranial pressure. CRRT minimizes rapid perturbations of the cardiovascular system, particularly in terms of blood volume and blood pressure, thereby reducing large variations in cerebral perfusion pressure and intracranial pressure. Patients with liver failure are one group at risk for developing cerebral edema, owing to difficulty in maintaining cerebral autoregulation of blood flow. Davenport (1999) has used C-HF and C-HD to cope with the increased intracranial pressure and cerebral edema. There are few data comparing CRRT versus SLED in this regard. In one study, SLED and CRRT had the same effects on intracranial pressure in patients being dialyzed after brain hemorrhage (Wu, 2013).

In patients at risk for cerebral edema, C-HF and C-HD systems using the new

generation of continuous machines with tight volumetric control and biocompatible membranes should be used. If possible, anticoagulation should be avoided, as it may increase the risk of intracerebral hemorrhage either at the site of injury or around an intracranial pressure monitor.

Dialysis or replacement fluid should have a relatively higher sodium (>140 mM) and a lower bicarbonate (30 mM) concentration. A higher sodium concentration will reduce the blood–brain osmotic gradient and minimize water movement into the brain. A rapid rise in plasma bicarbonate increases CO₂ movement into brain cells. Because bicarbonate ions are charged, they enter cells less readily than CO₂, thus causing a paradoxical decrease in brain pH. A sudden decrease in brain pH results in the generation of idiogenic osmoles, which increase the osmotic gradient favoring water entry into the brain.

In severe cases of uncontrolled intracranial pressure, cooling of the dialysis or replacement solutions may be helpful, in addition to other measures used to cool the patient to 32–33°C. At these temperatures, cranial oxygen demands are reduced (Davenport, 2001).

- B. **Sepsis and multiorgan failure.** Multiple organ dysfunction syndrome occurs as a result of an outpouring of proinflammatory (tumor necrosis factor β , thromboxane B₂, platelet activating factor) and anti-inflammatory mediators (interleukin-10). This response is provoked by gram-negative bacteria endotoxins, gram-positive bacteria, viruses, splanchnic ischemia, and trauma. With C-HF, many of these septic mediators are found in the filtrate of septic patients or are adsorbed to the filter membrane, suggesting that C-HF has the ability to remove septic mediators from the circulation. Use of high-volume C-HF has been advocated for such patients. However, although septic mediator concentrations are reduced by such treatments, a clinical benefit has not been consistently seen, so the benefits of higher-volume (2 L/hour) C-HF for such patients remain controversial. Nevertheless, many centers will treat septic patients with C-HDF instead of C-HD to increase removal of potential sepsis-mediating molecules while retaining the efficiency associated with use of dialysis. Using a clearance dose of 35 mL/kg per hour and dividing equally between dialysis and hemofiltration is a common strategy. See Joannidis (2009) for a review of this topic.
- C. **Acute lung injury and acute respiratory distress syndrome (ARDS).** Early institution of CRRT for volume removal may be helpful in improving oxygenation and ventilator parameters (PaO₂/FiO₂ ratio and oxygenation index) in patients with ARDS with concomitant acute renal failure. Respiratory improvement appears to be due more to the volume removal effect rather than to the removal of inflammatory mediators (Hoste, 2002).
- D. **Prevention of radiocontrast-induced nephropathy.** Although some studies found a benefit of periprocedural CRRT in patients with CKD undergoing IV contrast administration (Marenzi, 2003), the KDIGO 2012 AKI review group concluded that the evidence for CRRT use in this situation was not strong and does not recommend such intervention until more conclusive research has been done.
- E. **Intoxication with dialyzable or filter-permeable drugs or toxins.** Use of various modes of CRRT can be advantageous in treating various poisonings, especially when plasma levels are low (see

Chapter 20).

- F. **Extracorporeal membrane oxygenation (ECMO).** SCUF or C-HD may be performed on patients receiving ECMO without the need for a separate CRRT system. The ECMO blood lines can be adapted to connect in parallel to a dialyzer. This allows C-HD or SCUF to be performed concurrently. Because these patients have ARDS or volume overload that requires ECMO in the first place, further volume removal may be helpful, especially in patients with chronic renal insufficiency. When C-HD is desired for the treatment of concomitant ARF in these patients, use of sterile dialysis solutions is preferred, as there may be high backfiltration due to high pressures in the ECMO circuit. Anticoagulation using regional citrate has been used (Shum, 2014).

XVI. INFANTS AND CHILDREN. Use of CRRT in children is beyond the scope of this *Handbook*. See the review by Sutherland (2012).

References and Suggested Readings

- Augustine JJ, et al. A randomized controlled trial comparing intermittent with continuous dialysis in patients with ARF. *Am J Kidney Dis*. 2004;44:1000–1007.
- Baek NN, et al. The role of nafamostat mesylate in continuous renal replacement therapy among patients at high risk of bleeding. *Ren Fail*. 2012;34:279–285.
- Bart BA, et al.; the Heart Failure Clinical Research Network. Ultrafiltration in decompensated heart failure with cardiorenal syndrome. *N Engl J Med*. 2012;367:2296–2304.
- Bunchman TE, Maxvold NJ, Brophy PD. Pediatric convective hemofiltration: normocarb replacement fluid and citrate anticoagulation. *Am J Kidney Dis*. 2003;42:1248–1252.
- Chua HR, et al. Biochemical effects of phosphate-containing replacement fluid for continuous venovenous hemofiltration. *Blood Purif*. 2012;34:306–312.
- Churchwell MD, et al. Drug dosing during continuous renal replacement therapy. *Semin Dial*. 2009;22:185–188.
- Claire-Del Granado R, et al. Effluent volume in continuous renal replacement therapy overestimates the delivered dose of dialysis. *Clin J Am Soc Nephrol*. 2011;6:467–475.
- Cole L, et al. High-volume haemofiltration in human septic shock. *Intensive Care Med*. 2001;27:978–986.
- Dager WE, White RH. Argatroban for heparin-induced thrombocytopenia in hepato-renal failure and CVVHD. *Ann Pharmacother*. 2003;37:1232–1236.
- Davenport A. Is there a role for continuous renal replacement therapies in patients with liver and renal failure? *Kidney Int Suppl*. 1999;72:S62–S66.
- Davenport A. Renal replacement therapy in the patient with acute brain injury. *Am J Kidney Dis*. 2001;37:457–466.
- Egi M, et al. A comparison of two citrate anticoagulation regimens for continuous veno-venous hemofiltration. *Int J Artif Organs*. 2005;28:1211–1218.
- Egi M, et al. The acid-base effect of changing citrate solution for regional anticoagulation during continuous veno-venous hemofiltration. *Int J Artif Organs*. 2008;31:228–236.
- Eichler P, et al. Antihirudin antibodies in patients with heparin-induced thrombocytopenia treated with lepirudin: incidence, effects on aPTT, and clinical relevance. *Blood*. 2000;96:2373–2378.

- Fiaccadori E, et al. Efficacy and safety of a citrate-based protocol for sustained low-efficiency dialysis in AKI using standard dialysis equipment. *Clin J Am Soc Nephrol*. 2013;8:1670–1678.
- Fischer KG, van de Loo A, Bohler J. Recombinant hirudin (lepirudin) as anticoagulant in intensive care patients treated with continuous hemodialysis. *Kidney Int Suppl*. 1999;72:S46–S50.
- Golper TA. Update on drug sieving coefficients and dosing adjustments during continuous renal replacement therapies. *Contrib Nephrol*. 2001;132:349–353.
- Heintz BH, et al. Antimicrobial dosing concepts and recommendations for critically ill adult patients receiving continuous renal replacement therapy or intermittent hemodialysis. *Pharmacotherapy*. 2009;29:562–577.
- Hofmann CL, Fissell WH. Middle-molecule clearance at 20 and 35 ml/kg/h in continuous venovenous hemodiafiltration. *Blood Purif*. 2010;29:259–263.
- Hoste EA, et al. No early respiratory benefit with CVVHDF in patients with acute renal failure and acute lung injury. *Nephrol Dial Transplant*. 2002;17:2153–2158.
- Jacobi J et al. Clinical practice guidelines for the sustained use of sedatives and analgesics in the critically ill adult. *Crit Care Med*. 2002;30:119–141.
- James M, et al. Canadian Society of Nephrology Commentary on the 2012 KDIGO Clinical Practice Guideline for Acute Kidney Injury. *Am J Kidney Dis*. 2013;61:673–685.
- Jaski BE, et al. Peripherally inserted veno-venous ultrafiltration for rapid treatment of volume overloaded patients. *J Card Fail*. 2003;9:227–231.
- Joannidis M. Continuous renal replacement therapy in sepsis and multisystem organ failure. *Semin Dial*. 2009;22:160–164.
- Jörres A, et al.; the ad-hoc working group of ERBP. A European Renal Best Practice (ERBP) position statement on the Kidney Disease Improving Global Outcomes (KDIGO) Clinical Practice Guidelines on Acute Kidney Injury: part 2: renal replacement therapy. *Nephrol Dial Transplant*. 2013;28:2940–2945.
- KDIGO. KDIGO clinical practice guidelines for acute kidney injury. *Kidney Int*. 2012;2(suppl1):1–141.
- Kellum JA, Bellomo R, Ronco C, (eds). *Continuous Renal Replacement Therapy*. Oxford: Oxford University Press; 2010.
- Kim IB, et al. Insertion side, body position and circuit life during continuous renal replacement therapy with femoral vein access. *Blood Purif*. 2011;31:42–46.
- Kumar VA, et al. Extended daily dialysis: a new approach to renal replacement for acute renal failure in the intensive care unit. *Am J Kidney Dis*. 2000;36:294–300.
- Lexi-Comp, Inc. (Lexi-Drugs™). Lexi-Comp, Inc. May 22, 2013.
- Liangos O, et al. Dialyzer fiber bundle volume and kinetics of solute removal in continuous venovenous hemodialysis. *Am J Kidney Dis*. 2002;39:1047–1053.
- Lins RL, et al. for the SHARF investigators. Intermittent versus continuous renal replacement therapy for acute kidney injury patients admitted to the intensive care unit: results of a randomized clinical trial. *Nephrol Dial Transplant*. 2009;26:512–518.
- Lowenstein DH. Treatment options for status epilepticus. *Curr Opin Pharmacol*. 2005;5:334–339.
- Kalviainen R. Status epilepticus treatment guidelines. *Epilepsia*. 2007;48:99–102.
- Marenzi G, et al. Interrelation of humoral factors, hemodynamics, and fluid and salt metabolism in congestive heart failure: effects of extracorporeal ultrafiltration. *Am J Med*. 1993;94:49–56.

- Marenzi G, et al. The prevention of radiocontrast-agent-induced nephropathy by hemofiltration. *N Engl J Med*. 2003;349:1333–1340.
- Marshall MR, et al. Sustained low-efficiency daily diafiltration (SLEDD-f) for critically ill patients requiring renal replacement therapy: towards an adequate therapy. *Nephrol Dial Transplant*. 2004;19:877–884.
- Marshall MR, et al. Mortality rate comparison after switching from continuous to prolonged intermittent renal replacement for acute kidney injury in three intensive care units from different countries. *Nephrol Dial Transplant*. 2011;26:2169–2175.
- Matzke GR et al. Drug dosing consideration in patients with acute and chronic kidney disease—a clinical update from kidney disease: improving global outcomes (KDIGO). *Kidney Int*. 2011;80:1122–1137.
- McLean AG, et al. Effects of lactate-buffered and lactate-free dialysate in CAVHD patients with and without liver dysfunction. *Kidney Int*. 2000;58:1765–1772.
- Mehta RL. Indications for dialysis in the ICU: renal replacement vs. renal support. *Blood Purif*. 2001;19:227–232.
- Meier-Kriesche HU, et al. Unexpected severe hypocalcemia during continuous venovenous hemodialysis with regional citrate anticoagulation. *Am J Kidney Dis*. 1999;33:e8.
- Meier-Kriesche HU, et al. Increased total to ionized calcium ratio during continuous venovenous hemodialysis with regional citrate anticoagulation. *Crit Care Med*. 2001;29:748–752.
- Messer J, et al. Middle-molecule clearance in CRRT: in vitro convection, diffusion and dialyzer area. *ASAIO J*. 2009;55:224–226.
- Mitchell A, et al. A new system for regional citrate anticoagulation in continuous venovenous hemodialysis (CVVHD). *Clin Nephrol*. 2003;59:106–114.
- Monchi M, et al. Citrate vs. heparin for anticoagulation in continuous venovenous hemofiltration: a prospective randomized study. *Intensive Care Med*. 2004;30:260–265.
- Morgan D, et al. A randomized trial of catheters of different lengths to achieve right atrium versus superior vena cava placement for continuous renal replacement therapy. *Am J Kidney Dis*. 2012;60:272–279.
- Morgera S, et al. Long-term outcomes in acute renal failure patients treated with continuous renal replacement therapies. *Am J Kidney Dis*. 2002;40:275–279.
- Naka T, et al. Low-dose citrate continuous veno-venous hemofiltration (CVVH) and acid-base balance. *Int J Artif Organs*. 2005;28:222–228.
- Oudemans-van Straaten HM, et al. Citrate anticoagulation for continuous venovenous hemofiltration. *Crit Care Med*. 2009;37:545–552.
- Palevsky PM, et al. KDOQI US commentary on the 2012 KDIGO clinical practice guideline for acute kidney injury. *Am J Kidney Dis*. 2013;61:649–672.
- RENAL Replacement Therapy Study Investigators, Bellomo R, et al. Intensity of continuous renal-replacement therapy in critically ill patients. *N Engl J Med*. 2009;361:1627–1638.
- Rogiers P, et al. Blood warming during hemofiltration can improve hemodynamics and outcome in ovine septic shock. *Anesthesiology*. 2006;104:1216–1222.
- Rokyta R Jr, et al. Effects of continuous venovenous haemofiltration-induced cooling on global haemodynamics, splanchnic oxygen and energy balance in critically ill patients. *Nephrol Dial Transplant*. 2004;19:623–630.

- Sagedal S, Hartmann A. Low molecular weight heparins as thromboprophylaxis in patients undergoing hemodialysis/hemofiltration or continuous renal replacement therapies. *Eur J Med Res.* 2004;9:125–130.
- Salvatori G, et al. First clinical trial for a new CRRT machine: the Prismaflex. *Int J Artif Organs.* 2004;27:404–409.
- Schilder L, et al. Citrate confers less filter-induced complement activation and neutrophil degranulation than heparin when used for anticoagulation during CVVH in critically ill patients. *BMC Nephrol.* 2014;15:19.
- Schindler R, et al. Removal of contrast media by different extracorporeal treatments. *Nephrol Dial Transplant.* 2001;16:1471–1474.
- Shum HP, et al. The use of regional citrate anticoagulation continuous venovenous haemofiltration in extracorporeal membrane oxygenation. *ASAIO J.* 2014.
- Splendiani G, et al. Continuous renal replacement therapy and charcoal plasmapheresis in treatment of amanita mushroom poisoning. *Artif Organs.* 2000;24:305–308.
- Stevenson JM, et al. In vitro glucose kinetics during continuous renal replacement therapy: implications for caloric balance in critically ill patients. *Int J Artif Organs.* 2013;36:861–868.
- Sutherland SM, Alexander SR. Continuous renal replacement therapy in children. *Pediatr Nephrol.* 2012;27:2007–2016.
- Swartz R, et al. Improving the delivery of continuous renal replacement therapy using regional citrate anticoagulation. *Clin Nephrol.* 2004;61:134–143.
- Szamosfalvi B, Frinak S, Yee J. Automated regional citrate anticoagulation: technological barriers and possible solutions. *Blood Purif.* 2010;29:204–209.
- Teo BW, et al. Machine generated bicarbonate dialysate for continuous therapy: a 10-year experience. *Blood Purif.* 2006;24:247–273.
- Troyanov S, et al. Phosphate addition to hemodiafiltration solutions during continuous renal replacement therapy. *Intensive Care Med.* 2004;30:1662–1665.
- Van Berendoncks AM, et al.; SHARF Study Group. Outcome of acute kidney injury with different treatment options: long-term follow-up. *Clin J Am Soc Nephrol.* 2010;5:1755–62.
- van der Sande FM, et al. Thermal effects and blood pressure response during postdilution hemodiafiltration and hemodialysis: the effect of amount of replacement fluid and dialysate temperature. *J Am Soc Nephrol.* 2001;12:1916–1920.
- Wester JP, et al. Catheter replacement in continuous arteriovenous hemodiafiltration: the balance between infectious and mechanical complications. *Crit Care Med.* 2002;30:1261–1266.
- Wu MY, et al. Regional citrate versus heparin anticoagulation for continuous renal replacement therapy: a meta-analysis of randomized controlled trials. *Am J Kidney Dis.* 2012;59:810–818.
- Wu VC, et al.; the NSARF Group. The hemodynamic effects during sustained low-efficiency dialysis versus continuous veno-venous hemofiltration for uremic patients with brain hemorrhage: a crossover study. *J Neurosurg.* 2013;119:1288–1295.
- Yagi N, et al. Cooling effect of continuous renal replacement therapy in critically ill patients. *Am J Kidney Dis.* 1998;32:1023–1030.
- Yang Y, et al. Development of an online citrate/Ca²⁺ sensing system for dialysis. *Analyst.* 2011;136:317–320.
- Yessayan L, et al. Treatment of severe hyponatremia in patients with kidney failure: Role of

continuous venovenous hemofiltration with low sodium replacement fluid. *Am J Kidney Dis.* 2014;64:305–310.

Web References

ADQI Initiative: <http://www.adqi.org>.

HDCN CRRT Channel: <http://www.hdcn.com/ch/cavh/>.

KDIGO Clinical Practice Guideline for Acute Kidney Injury:
http://www.kdigo.org/clinical_practice_guidelines/AKI.php.

Interest in home hemodialysis (HD) continues to grow. Provider and patient preferences, decreasing costs of equipment and consumables, new funding models, and more user-friendly technology may be facilitating factors. Moreover, the home setting lends itself well to longer and more frequent (collectively, “intensive”) HD sessions than are typically available in-center, though these intensified regimens can be provided in-center as well. It is useful to distinguish between (a) conventional HD (3–5 hours, 3 per week), (b) frequent HD (5–7 per week), which can be frequent short (1.5–3 hours), frequent standard (3–5 hours), or frequent long (>5 hours), or (c) long-session-length regimens (>5 hours) given 3 days per week or every other day. Short and standard frequent HD are typically referred to as “daily HD” (DHD), while long, frequent HD is typically done at night and is called frequent “nocturnal HD” (NHD).

I. MODALITY SELECTION. In the absence of evidence-based practice guidelines addressing modality selection, we propose some general guiding principles: (a) patients approaching renal replacement therapy should receive education regarding all available modality options, including conservative care without dialysis, preemptive transplantation, home HD, peritoneal dialysis (PD), and in-center HD; (b) where medically appropriate and feasible, home modalities (including PD) should be promoted as first-line therapies when transplantation is not imminent; (c) the choice between PD and home HD should be based on patient preference, availability, feasibility, and medical factors (e.g., patients seeking pregnancy should preferentially receive frequent NHD; patients at risk for suboptimal clearance with PD should consider home HD); (d) home HD should be considered following the failure of PD or a renal allograft—this approach requires carefully timed education and planning, but can lead to more patients maintaining their independence from center HD; and (e) more intensified (home or center) HD regimens may be considered to improve extracellular fluid volume (especially in those with high fluid gains), blood pressure (BP), left ventricular (LV) mass, phosphate, and quality of life.

A. Frequent versus conventional HD. Prescription patterns vary geographically, and also according to program and provider preferences. There are no evidence-based guidelines that directly address the choice between conventional and frequent (long or short) HD. In the majority of cases, the treatment schedule will depend on patient preferences (such as convenience and noninterference with work, sleep, and social schedules), as well as clearance and ultrafiltration needs. Starting with one particular regimen does not preclude switching to

another at any time, and many patients have used combinations of long and short treatments to accommodate work and other schedules. Where possible, we recommend avoiding a 3-day interdialytic interval, setting a lower boundary of every other day for home HD, though this approach is less likely to be available in-center.

B. Home HD

1. **Patient selection.** Reported prevalent rates for home HD are generally <5% in most jurisdictions, but as high as 15% in others. The primary prerequisite for home HD is a willing patient or partner who is able to learn to safely perform the dialysis procedure. Uncontrolled seizures, hypoglycemia, noncompliance with medical care, and significant intradialytic hemodynamic instability requiring frequent nursing interventions are relative contraindications. Inability to use heparin precludes long HD with lower blood flow rates (e.g., 150 mL/min), but not prescriptions with higher (e.g., >300 mL/min) blood flow. The presence of multiple or severe comorbidities are not contraindications to home HD, but frailty and inability to perform self-care HD may represent significant barriers if no assistance is available. Home HD programs should develop standardized intake procedures, and criteria for home HD eligibility should include the patient's or helper's motor skills, strength, vision, hearing, reading ability, motivation, and adherence. When significant functional barriers are identified, paid caregivers can be considered, if available.
2. **Home environment suitability.** The home needs to be assessed by a renal technologist, focusing on (a) water quantity and quality, (b) electrical supply, (c) storage space, and (d) cleanliness. These rarely pose insurmountable barriers to home dialysis, though the patient must understand the nature and extent of the changes needed in order to accommodate the necessary equipment. Local building codes should be adhered to, and, occasionally, permission from landlords must be sought prior to beginning any alterations to plumbing and electrical infrastructure.

- C. **In-center HD.** Reasons for choosing in-center over home-based HD include (a) patient safety concerns, (b) vascular access or cannulation problems, (c) patient or partner inability or unwillingness to perform the HD procedure at home, (d) unsuitable home environment (space, electrical, hygiene, or plumbing limitations), and (e) patient preference.

While conventional regimens predominate in-center, intensified center HD is increasingly available, with practices varying by jurisdiction. In Canada, Australia, and Europe, DHD is offered for a wide range of indications, including (a) refractory volume overload, (b) refractory hyperphosphatemia and/or calciphylaxis, (c) failure to thrive, and (d) pregnancy, though evidence to support these indications is limited. In France, long, thrice-weekly, in-center, daytime HD is common, and long, thrice-weekly HD at night is becoming increasingly available in the United States. Long, frequent NHD is not usually done in-center. Transportation, proximity to the treatment center, patient lifestyle, and demands on the patient's family are important factors that may determine whether in-center intensive HD is considered. In-center intensified regimens also impose increased demands on space, equipment, and nursing and technical support staff. In general, programs require a "critical mass" of patients receiving intensified regimens to maintain a pool of adequately

trained staff and to realize economies of scale. Lack of availability of overnight staff and ability to rapidly “turn over” larger numbers of DHD treatments may require alternative staffing models.

II. TECHNICAL CONSIDERATIONS FOR HOME HD

- A. **Training.** The length of the training period depends on the patient's previous experience with HD. Without prior experience, patients typically require one-on-one training with an experienced nurse for at least 6 weeks to become safe and proficient, while patients previously undergoing self-care HD require less training time. Some programs with long wait times for home HD training offer training in self-care HD units. Educational manuals written in the patient's language at the appropriate reading and comprehension level are also useful. Many programs require patients to “recertify” annually, by demonstrating in the training unit setting that they are able to correctly perform the dialysis procedure and blood access, and troubleshoot effectively.
- B. **Vascular access.** The Canadian Society of Nephrology (CSN) guidelines for the management of patients with ESRD (end-stage renal disease) treated with intensive HD (Nesrallah, 2013) recommend arteriovenous (AV) fistulae and grafts over catheters, because of lower infection risk (conditional/weak recommendation, very low quality evidence), but acknowledge that the technical demands of cannulation may represent a barrier to home HD for some patients.

In patients with AV fistulae, the “buttonhole” technique, which involves recannulation of precisely the same two (or two pairs of) sites with blunt needles, has been popular as it may be easier to learn than the standard, “rope-ladder” (rotating site), method (see Chapter 6). However, buttonhole cannulation may result in higher rates of *Staphylococcus aureus* bacteremia (Muir, 2014), and as such, the CSN guidelines recommend using the buttonhole method in conjunction with topical antimicrobial prophylaxis with mupirocin (conditional/weak recommendation, very low quality evidence) (Nesrallah, 2010, 2013). With synthetic grafts, needle sites are rotated in the usual fashion. Low blood flows of 200–250 mL/min and single needle are sufficient for NHD, where high dialysis efficiency is not required.

- C. **Dialysis membranes.** Currently, there are no data to support the use of one kind of dialysis membrane over another in home HD. In recent years, most centers have reported using high-flux dialyzers. Low dialyzer surface area can be acceptable for long HD (Pierratos, 1999). Dialyzer reuse has been described in home dialysis (Pierratos, 2000) but has largely been abandoned with the fall in prices of dialysis membranes.
- D. **Patient safety and precautions.** Appropriate patient selection, training, and ongoing supervision are of utmost importance to ensure patient safety at home. The dialysis machine screen should be easily visible at all times, from whichever position the patient dialyzes, and the controls should be easily accessible. Some additional precautions include the following:
1. **Alarms and communication.** The patient (or caregiver) must be able to hear the dialysis machine and its alarms and be trained on how to respond to them. Patients must have a telephone within hand-reaching distance of the dialysis machine to contact

emergency services, if needed. Some programs prefer a wired (noncordless) landline telephone over a cellular phone, to ensure function during power failure or inadequate network reception. The telephone ringer must be audible by the patient in case of contact attempts by a remote monitoring center.

2. **Prevention of line disconnection**

- a. **Proper cannulation technique.** Patient or caregiver competence with the cannulation procedure and with securing the cannula are mandatory prerequisites for home treatment.
- b. **Securing lines.** Meticulous taping of the blood tubing connection to the dialysis catheter is very important to prevent exsanguination from accidental disconnection. Plastic clamshell locking boxes have been used to prevent catheter–tubing separation (Pierratos, 1999). A small blood line connector clip (HemaSafe, Fresenius NA, Lexington, MA) is widely available.

3. **Prevention of morbidity when lines disconnect**

- a. **Closed connector devices.** The use of a closed connector device is recommended if the patient performs dialysis while asleep (conditional/weak recommendation, very low quality evidence) (Nesrallah, 2013) to prevent air embolization and bleeding resulting from accidental disconnection of the tubing from the dialysis catheter. These are catheter caps with a slit diaphragm, allowing blood flow while in place. They are replaced periodically from every week to every month depending on local practices and manufacturer recommendations. The InterLink System (Becton Dickinson, Franklin Lakes, NJ) can be used only for long HD, as it results in increased arterial and venous pressures at the higher pump speeds used in other regimens. The TEGO (ICU Medical, CA) connector provides less resistance to flow and can be used with higher blood flow rates. The Swan-Lock connector (Codan, Lensahn, Germany) has also been used.
- b. **Moisture detectors.** An enuresis alarm, such as the Drisleeper (Alpha Consultants Ltd., Nelson, New Zealand), can be attached to the cannula entry points to detect bleeding. Disposable leak detectors are also available (RedSense Medical AB, Halmstad, Sweden). A wireless wetness detector, which stops the machine blood pump, was recently released (Fresenius Medical Care, Lexington, MA). Finally, moisture sensors can be placed on the floor around the machine and near the water supply to detect blood, dialysate, and water leaks (Pierratos, 2000).
- c. **Two-pump, single-needle system.** In case of accidental disconnection of the venous line, substantial blood loss and even exsanguination can occur. As discussed in Chapter 4, one cannot rely on a drop in the venous line pressure after line disconnection to stop the blood pump, and the technology described above must be relied upon. Single-needle dialysis reduces the risk of bleeding due to line disconnection, as bleeding will then be restricted to flow from the fistula or catheter, rather than via the blood pump. For this reason, single-needle dialysis is likely to be a safer option for frequent NHD performed at home. Given the length and frequency of sessions with long HD, the slightly reduced clearance associated with single-needle HD is not a major concern.

4. **Monitoring.** Monitoring is typically only considered for NHD. A modem or high-speed Internet connection of the HD machine to specialized equipment can allow for software-based real-time monitoring to detect technical problems and alarms as they arise (e.g., air and blood leaks). Monitoring is also a useful means by which to track treatment adherence. Rarely are patient data such as BP monitored during night-time dialysis; thus, while monitoring provides patient reassurance and security, it is unclear whether monitoring actually prevents catastrophic events. Some jurisdictions require live remote monitoring by law (e.g., New York), but most programs use it for home NHD for the first 3 months (Heidenheim, 2003); some programs do not use it at all (Humber River Hospital, Toronto). iCare (Fresenius Medical Care, Lexington, MA) is one such commercially available real-time monitoring system. Automated telephone response systems have also been used with variable success.

III. INFRASTRUCTURE REQUIREMENTS FOR HOME HD

- A. **Support staff.** Specially trained nurses, biomedical technicians, and physicians are required. Nurses are required for assessment and training, telephone follow-up and troubleshooting, ordering of patient supplies, and home visits, while technicians provide machine maintenance and monitor water quality. Biomedical engineering personnel should be involved in the development of local policies governing practices, standards, and protocols for the installation and maintenance of equipment. The dialysis program's payment carrier should be informed of any changes to services provided.
- B. **Space.** Adequate clinic space with appropriate plumbing is needed to allow patient training, patient assessments, and follow-up clinic visits with the physician and allied health personnel.
- C. **Water supply.** Water quality should be assessed regardless of the source. Endotoxins, mineral content, and chloramines should be quantified. Rural water supplies must also be tested for coliform bacteria. International standards exist for water purity (see Chapter 5) and should be followed. Water purification system and HD equipment manufacturers typically specify water pressure requirements.
 1. **Water purification.** Both reverse osmosis and deionization systems have been used successfully in home dialysis. Purification systems have become increasingly compact and quiet enough to install in a patient's bedroom, though more remote installation is also possible where desired. Patients should be instructed in maintenance procedures for their water systems, including filter changes and disinfection of lines and units. Ultrapure dialysate (generated by using an ultrafilter) has also been used by most programs and may be preferable for NHD, where the quantity of dialysate exposure (~108–144 L per session) can compound the effects of inferior water quality. Disinfection and water sampling frequency (usually monthly) will depend on the system utilized and must follow national water standards.
- D. **Dialysis machines.** No existing data favor the use of any one type of HD machine over another; thus, any machine that can be used for in-center therapy can be used for home daily dialysis. Some machines are large, cumbersome, and difficult to use, though there appears to be a growing interest in producing machines that are better suited to home dialysis.

Noise is a factor for machines used for NHD. Other considerations in home HD machine design include simplicity/ease of use, visibility of the screen and accessibility of controls, short setup, and simple maintenance and disinfection procedures.

The NxStage System One (NxStage Medical Inc., Lawrence, MA) is described separately, as it differs from other devices in the use of lower dialysate flow rate with prefilled dialysate bags, as well as a cartridge-based dialyzer and tubing setup (Clark and Turk, 2004). Their lactate-based dialysate can be delivered in ready-made 5-L bags or can be produced by the PureFlow™ system from powdered dialysate mix, and made up in volumes of between 15 and 60 L for longer treatments. The amount of water needed is similar to the dialysate volume, as is the case when deionizers are used. The NxStage device is transportable and can be used when traveling. It requires fewer or no renovations at the home of the patient. One limitation of the NxStage device at the present time is a maximal dialysate flow rate of 200 mL/min. Although there is no incorporated heparin pump, low-molecular-weight heparin or an external heparin pump can be utilized. The clinical significance of low dialysate flow is discussed in the adequacy and dose section below.

1. **Equipment maintenance programs.** These are central to patient safety. Most manufacturers provide suggested maintenance schedules, and these should serve as a bare minimum requirement to prevent complications and equipment failure. In addition to a rigorous water purification maintenance schedule, microbiological and endotoxin screening of product water and dialysis solution are critically important, particularly with high-flux membranes. Some recommend doing such screening monthly.
- E. **Remote overnight monitoring.** Commercially available devices and software tools are listed above. Programs may choose to have their own central monitoring station with trained overnight personnel; alternatively, one centralized station for multiple programs may be considered to reduce costs.

IV. PRESCRIPTION OF INTENSIVE HD

A. Physiological rationale

1. **Solute removal advantage of increased weekly dialysis time.** For solutes like poorly dialyzed middle molecules, the plasma concentration does not change much during dialysis, and for this reason, the main factor governing removal is total weekly dialysis time. Distributing the same weekly time over more frequent sessions is of limited benefit. This is true for phosphate as well. The intradialytic concentration of phosphate falls precipitously during the first hour of dialysis, but then plateaus; as a result, weekly phosphate removal depends primarily on total weekly dialysis time.
2. **Solute removal advantage of increased frequency.** For solutes such as urea, and for the theoretically “sequestered” solutes modeled using standard Kt/V (for a description of standard Kt/V [$stdKt/V$] see Chapter 3), the intradialytic plasma concentration continues to fall as a dialysis session progresses for this reason, prolongation of a dialysis session beyond 4 hours is of limited benefit, and it is advantageous to distribute the same weekly time over more frequent sessions. The most efficient solute removal occurs during the early part of the dialysis session, when the plasma solute

concentration is the highest. The standard Kt/V measure best reflects the effect of more frequent dialysis schedules on highly sequestered, but easily dialyzable solutes.

There also is an advantage for phosphorus removal in terms of increasing dialysis frequency, as removal of phosphorus is substantially higher during the initial hour of dialysis than during the “plateau phase.” When the weekly dialysis time is long (>20 hours), the total weekly time is the main determinant of phosphorus removal. When weekly dialysis time is <12 hours, breaking this up into six, as opposed to three, sessions per week often will decrease predialysis serum phosphorus level, albeit slightly.

3. **Ultrafiltration advantage of increasing weekly dialysis time.** The amount of fluid that needs to be removed per week will be a function of weekly fluid ingestion minus weekly residual urine volume. If one doubles the weekly dialysis time, and if fluid ingestion remains constant, the ultrafiltration rate will be halved, greatly reducing hemodynamic stress associated with fluid removal.
4. **Ultrafiltration advantage of increasing dialysis frequency.** Even if weekly dialysis time is not increased, there may be some advantage to increasing frequency, because at the beginning of a dialysis session, more of the excess fluid is associated with the central blood volume compartment. In the FHN “Daily” Trial (Chertow, 2010), where weekly dialysis time was increased marginally, and in which weekly fluid ingestion also increased slightly, there was a benefit in terms of reduction of intradialytic hypotensive episodes per treatment, but as a greater number of treatments per week were given, the number of hypotensive episodes per week was increased.
5. **Benefit of avoiding a long interdialytic interval.** Observational studies show that in patients being dialyzed with three-times-per-week schedules, mortality is highest on Mondays in patients following a Mon-Wed-Fri schedule, and on Tuesdays in patients following a Tues-Thurs-Sat schedule. It is not clear whether the increased mortality is due to the requirement for increased fluid removal or to the buildup of various uremic toxins, including potassium, over the 3-day weekend interdialytic interval. This observation argues against use of a three-times-per-week schedule at home in situations where an every-other-day schedule is feasible.
6. **Potential adverse effect of frequent, long nocturnal hemodialysis schedules on residual kidney function.** In the FHN Nocturnal Trial, it was noted that the loss of residual kidney function was accelerated in those patients who were dialyzing more often than 4.5 times per week using long session lengths (weekly dialysis time longer than 28 hours per week) (Daugirdas, 2013). This was not found in patients with shorter weekly dialysis times. This observation needs to be confirmed, but in patients with substantial residual kidney function, a very intensive (frequent and long) dialysis schedule may not be optimal unless needed to control refractory volume overload or hyperphosphatemia.

B. Adequacy and urea clearance

1. **Standard Kt/V .** The standard Kt/V ($stdKt/V$) concept that has been described in Chapters 3 and 11 is generally used to quantify urea clearance in DHD and NHD. $StdKt/V$ is a frequency-independent measure of dialysis dose. It is a weekly expression

(normalized to V) of a modified equivalent urea clearance, and is defined as the urea generation rate divided by the mean peak predialysis serum urea nitrogen (SUN) level. The effect of dialysis frequency on the $stdKt/V$ can more easily be seen graphically, and is shown in Figure 16.1. It can be seen that when three-times-per-week dialysis sessions are given, each lasting about 3.5 hours and delivering a single-pool (sp) Kt/V of 1.2, the resulting $stdKt/V$ will be 2.15 (when calculated using modeling or the so-called “FHN equation”). Increasing the $spKt/V$ using a three-times-per-week schedule has only a modest effect on increasing $stdKt/V$. One can see that, to achieve the same $stdKt/V$ of 2.15 using six-times-per-week SDHD (short daily hemodialysis), an $spKt/V$ of about 0.5 needs to be delivered during each session. For simplified methods of calculating $stdKt/V$ see Appendix C.

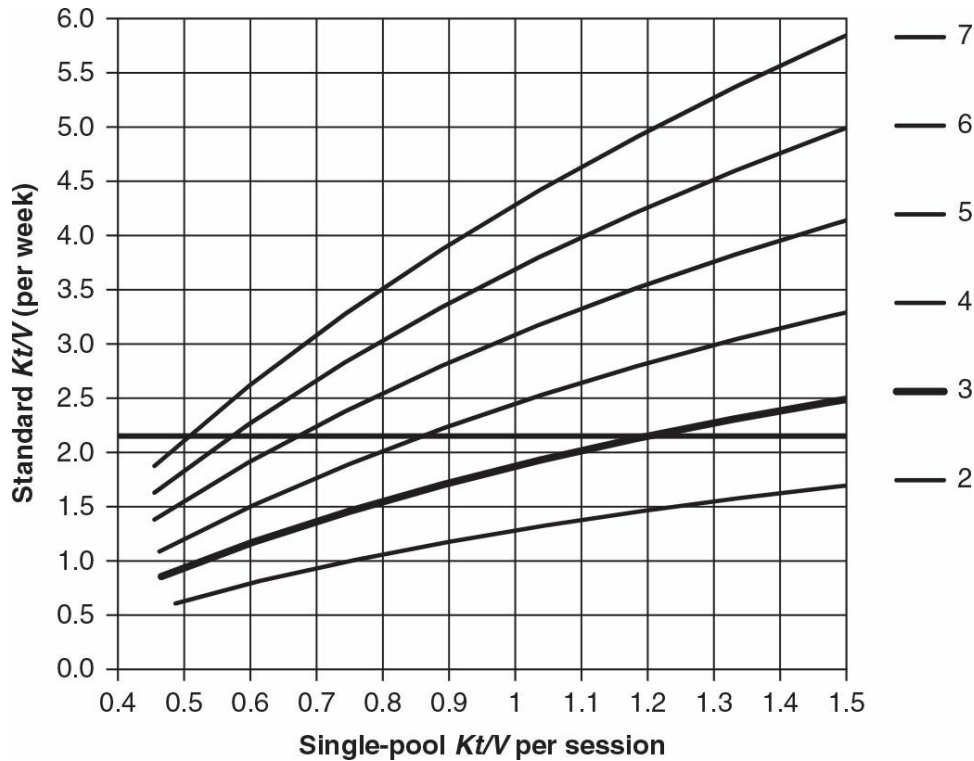

FIGURE 16.1 The relationship between weekly $stdKt/V$ and per-dialysis single-pool Kt/V ($spKt/V$). The data assume a patient V of 40 L, dialyzer clearance of 200 mL/min, and dialysis time ranging from 30 to 270 min. The horizontal line at 2.15 represents the $stdKt/V$ (calculated using the FHN method or urea kinetic modeling) associated with the KDOQI minimum session $spKt/V$ of 1.2 with a 3 per week dialysis session. The numbers on the right show number of treatments per week.

2. Prescription recommendations for Urea Clearance

- a. **DHD.** Patients following a six-times-per-week DHD schedule have been treated with session lengths ranging from 1.5–3 hours (Table 16.1) six times weekly, corresponding to weekly dialysis times of 9–18 hours. Blood and dialysate flow rates are usually similar to those in conventional dialysis, as well as dialyzers. In the FHN Daily Trial, patients receiving DHD received an average standard Kt/V of 3.6 per week, corresponding to an average equilibrated Kt/V of 1.06 per session given on average 5 times per week. It is reasonable to start with 2-hour treatments, 12 hours per week. This schedule may then be adjusted depending on

the measured delivered dose and patient satisfaction, remembering that every dialysis session need not be of the same length. In selected patients, further increases in dialysis session length (beyond 2 hours) should be considered, as this may be of help in removing more phosphate and also salt and water, as described below. DHD sessions in the 1.5-hour range may be sufficient for those with substantial residual renal function, but weekly $stdKt/V$ should be monitored.

- b. **NHD.** With HD for 6–10 hours, three or more times per week, $stdKt/V$ values will typically be well above 2.0, assuming that an $spKt/V$ of at least 1.2 is delivered per session. The $stdKt/V$ is affected to a modest degree by session length, and going from a 3.5- to a 6- to 10-hour session per se results in a modest increase in $stdKt/V$ for three-times-per-week dialysis, even when $spKt/V$ is unchanged. Because of the marked increase in clearance with NHD, submaximal blood flows with single-needle dialysis can be used to optimize safety, and lower dialysate flows may be used to save water costs. We recommend a Q_b of 200–250 mL/min with single needle, with Q_d of 300 mL/min. In the FHN Nocturnal Trial, the typical prescription was at least 6 hours, given on average 5 nights per week, achieving a $stdKt/V$ of 5.0.

TABLE

16.1

Typical SDHD and Frequent NHD Prescriptions

	SDHD	Frequent NHD
Frequency (sessions per week)	6–7	5–7
Duration (hours)	1.5–3.0	6–10
Dialyzer (high-flux preferred)	Any	Any (smaller)
Q_B (mL/min)	400–500	200–300
Q_D (mL/min)	500–800	100–300
Access	Any	Any
Remote monitoring	None	Optional
Dialyzer reuse	Optional	Optional

NHD, nocturnal hemodialysis.

C. **Dialysate composition.** There is little evidence on optimal dialysate composition for frequent and long-duration HD. Similar dialysate composition may be used when switching from conventional dialysis to frequent or long-duration HD, with the exception that bicarbonate may need to be reduced and phosphate may need to be added. Dialysate composition should be individualized to achieve pre- and postdialysis levels in the local laboratory “normal” range (see below). A typical dialysate contains Na^+ 135–140 mM, K^+ 2.0–3.5 mM, HCO_3^- 28–34 mM, Ca^{++} 1.25–1.75 mM (2.5–3.5 mEq/L), and Mg^{++} 0.5 mM (1 mEq/L).

1. **Bicarbonate:** HCO_3^- concentration should be adjusted to achieve a predialysis

bicarbonate of 22–24 mmol/L. We usually start with a bicarbonate of 28–33 mmol/L for patients receiving frequent HD (either DHD or NHD). One must remember that the bicarbonate concentration readout on most dialysis machines does not take into account the alkalinizing effect of sodium acetate or sodium citrate present in bicarbonate dialysate solutions. Especially with frequent, long NHD, the dialysis solution bicarbonate should be set toward the lower end to limit the occurrence of postdialysis alkalemia.

2. **Phosphorus.** To control serum phosphorus in patients ingesting a usual amount of protein, about 24–28 hours per week of dialysis is required in the absence of phosphorus binder ingestion. Increasing dialysis frequency in SDHD without increasing weekly dialysis time will have only a trivial effect on serum phosphorus, especially because many patients will tend to increase their protein and phosphorus intake. Patients treated with three nocturnal sessions per week, or every other night nocturnal dialysis will have a more marked reduction in serum phosphorus, and some may no longer need phosphorus binders, although a substantial number will continue to require them. Those patients treated with long sessions 5–6 times per week typically will go into negative phosphorus balance unless some phosphate is added to the dialysate. Whereas hypophosphatemia at the end of dialysis is common, predialysis hypophosphatemia is undesirable and is associated with an elevated risk of mortality. Hypophosphatemia can be exacerbated during periods of reduced food intake, for example, during intercurrent illness. For this reason, most patients dialyzed more than 30 hours per week will need some phosphate added to the dialysate.

Sodium phosphate preparations have been used to enrich dialysate with phosphorus to prevent or treat hypophosphatemia in patients treated with chronic high-intensity dialysis. The dialysate phosphorus concentration is usually 0.32–0.65 mM (1–2 mg/dL) although higher concentrations may be necessary in some patients. The phosphate can be added to either the acid or the bicarbonate liquid concentrate. Enema preparations containing sodium phosphate (C. B. Fleet Company, Lynchburg, VA) consisting of a mixture of $\text{NaH}_2\text{PO}_4 \cdot \text{H}_2\text{O}$ and $\text{Na}_2\text{HPO}_4 \cdot 7\text{H}_2\text{O}$ have been widely used for this purpose. However, nonrectal use of phosphate enemas has not been approved by the U.S. Federal Drug Administration (FDA), and the purity of such phosphate preparations is not known. The enema solutions do contain a small amount of benzalkonium chloride (a biocide and preservative) and disodium EDTA, which are then massively diluted further in the final dialysis solution. An alternative method of phosphate supplementation is to add an appropriate amount of phosphorus using USP-grade (United States Pharmacopeia) sodium phosphate salts (Sam, 2013). Phosphate preparations for intravenous use (Trojanov, 2004; Hussain, 2005) have been added to hemodiafiltration solutions to increase their phosphorus concentration, but their routine use in long nocturnal dialysis would be quite expensive owing to the large volume of dialysis solution needed.

3. **Calcium.** Patients receiving frequent, long NHD can deplete their total-body calcium unless a slightly higher-than-usual dialysis solution calcium concentration is used (Al Hejaili, 2003). Use of a dialysate calcium concentration of 2.5 mEq/L (1.25 mM) in

such patients has been shown to result in hyperparathyroidism that is refractory to vitamin D analog therapy, especially if the patient is no longer taking calcium-based phosphorus binders. The ideal dialysate calcium concentration for an individual patient will vary with dietary calcium intake, ingestion of supplemental calcium (including calcium-based phosphorus binders), vitamin D analog use, ultrafiltration volume, and the level of parathyroid gland activity. Measurement of pre- and postdialysis calcium levels can help identify an ideal bath calcium concentration for a given patient. The CSN clinical practice guideline for intensive HD (Nesrallah, 2013) currently recommends using a dialysate calcium of 1.5 mM (3.0 mEq/L) or higher for long, frequent HD. If concentrates with the desired calcium concentration are not available, one can add the required amount of powdered calcium chloride (the Humber program uses $\text{CaCl}_2 \cdot 2\text{H}_2\text{O}$ USP) to the acid concentrate. The need for a higher dialysate calcium is a problem only for long, frequent NHD; SDHD is not associated with marked changes in calcium levels, and for these treatments, standard dialysate calcium concentrations of 1.25 mM (2.5 mEq/L) are typically used.

D. **Anticoagulation.** Long HD with slow blood pump speeds generally cannot be performed without anticoagulation. Standard heparin protocols may be used for all frequent HD schedules. Some programs have used low-molecular-weight heparin as a bolus with or without a mid-dialysis top-up dose for longer session length treatments, but published evidence of safety and efficacy is lacking.

E. **Ultrafiltration, adjustment of target weight, and antihypertensive medications.** Improvement in BP control may be noted as early as 1 week after changing to intensified HD, is most marked within the first few months, and may continue for many months thereafter. Not uncommonly, the BP may be so markedly improved by long or frequent HD that a patient will no longer need antihypertensive drugs. Cardioprotective agents such as angiotensin-converting enzyme inhibitors or beta-blockers may still be prescribed, if desired, but at lower doses as tolerated.

Target weight with intensive HD is set as per usual practice, aiming for clinical euvolemia and normal pre- and postdialysis BP, while avoiding intradialytic hypotension and symptoms. Larger interdialytic weight gains can be expected as patients liberalize dietary sodium and fluid intake with longer and more frequent sessions. Patients can be trained to self-adjust ultrafiltration goals on the basis of weight and BP parameters, making small incremental changes (e.g., 0.3–0.5 kg per session) to their target weights until desired values are achieved.

F. **Follow-up**

1. **Clinic visits.** Most patients should be seen within 2–4 weeks of starting home therapy, then monthly for 3 months, then every 2–3 months thereafter. This assumes that 24-hour on-call nursing support is available. The use of dialysis “run sheets” allows for documentation of weights, BP, and intradialytic complications. Patients should bring these to each clinic visit.
2. **Blood tests.** Patients dialyzing at home can be provided with blood centrifuges and can be instructed in the proper handling and preparation of blood samples.

V. COMPARATIVE EFFECTIVENESS AND SAFETY OF HOME AND INTENSIVE HD VERSUS OTHER MODALITIES

A. **Conventional Home HD.** To date, there have been no trials comparing home with center HD. Observational studies have suggested better survival with home HD, but unmeasured patient characteristics, including health literacy, motivation, psychological well-being, social support structures, functional ability, and socioeconomic factors, may account for the greater survival rates observed in home HD populations. Patient unwillingness to be randomly allocated to the home or in-center setting is a major barrier to conducting randomized trials. Although not directly measured, the freedom associated with self-scheduling, self-management, and more liberal diet likely improve patient quality of life with home HD.

B. **Frequent HD**

1. **Short and standard frequent HD.** No clinical trials have compared home DHD with any other modality. An observational study from Australia suggested no mortality difference between patients receiving intensive home HD compared with those receiving conventional home HD (Marshall, 2011). In the FHN Daily Trial, patients who received SDHD in-center had statistically and clinically significantly better SF-36 (physical composite summary) scores and regression of ventricular hypertrophy compared with patients who received conventional center HD (Chertow, 2010). It should be noted that the delivered treatments in these patients averaged 2.5 hours in duration, and were given on average 5.2 times per week. There is preliminary evidence that survival was better in the patients randomized to the frequent-treatment arm (Chertow, 2013). A recent multinational survival study showed a higher risk of death with SDHD; however, this study was prone to residual confounding, as patients treated with SDHD likely had higher (unmeasured) baseline risk than could be adjusted for in statistical models (Suri, 2013). Although there are several observational studies evaluating physiological outcomes with DHD, the FHN Daily Trial provides the least biased estimates of these effects. In this study, patients receiving SDHD had better phosphate and BP control, but no differences in nutritional variables, anemia management, mental health, or cognitive function were detected.

An important safety signal in the FHN trials was an increased need for interventions to maintain AV access patency. Whether this was due to differential surveillance (more frequent visits) or an effect of frequent cannulation was not clear. There was a trend to reduced complications with buttonhole cannulation, with DHD (Suri, 2013 [JASN]).

2. **Long, frequent HD.** To date, two randomized trials have compared frequent NHD with conventional HD. A Canadian study demonstrated regression of left ventricular hypertrophy (LVH) among patients randomized to NHD (Culleton, 2007), while the larger FHN nocturnal study did not (Rocco, 2011). The effect of NHD on LV mass may have been attenuated by preserved residual renal function in the FHN study population. Both studies found improved BP and phosphate control with NHD. Studies evaluating the effects of NHD on patient survival have been observational. As with studies of conventional home HD, NHD is associated with greater survival compared with

conventional HD, but residual confounding should be considered when interpreting these results.

In the FHN Nocturnal Trial, procedures to maintain the vascular access were significantly increased with home long, frequent HD compared with conventional home HD, and there was a trend to increased perceived burden on caregivers as well. Finally, patients who received frequent NHD had increased risk of complete loss of residual renal function at 12 months compared to patients assigned to a 3-days-per-week schedule. These potential adverse effects should be discussed with patients before starting frequent NHD. The mortality effects are unclear; patients randomized to the six-nights-per-week group had an increased risk of long-term mortality compared with those randomized to conventional HD (Rocco, 2013), but the significant cross-over rates and minute sample size preclude definitive interpretation of these results.

- C. **Long-session dialysis given three times per week or every other day.** The Tassin experience showed marked improvements in survival, BP, and phosphate control among recipients of thrice-weekly in-center HD lasting 8 hours per session (Charra, 2004). More recently, large dialysis organizations in the United States have provided three-per-week in-center NHD and have reported better survival and physiological variables compared with conventional center HD; the published experience with every-other-day home HD in Australia and New Zealand has shown similar results. However, all of this evidence is observational, with the potential problem of bias due to patient selection and confounding.

VI. **CONCLUSIONS AND FUTURE DIRECTIONS.** Home dialysis in general, as well as intensified HD regimens are increasing in popularity, particularly in high-income countries. Efforts to understand the benefits and risks of such alternative dialysis prescriptions continue to rely on observational studies, as randomized trials are quite difficult to carry out in this area. Until higher-quality evidence is available to inform decision making, providers would serve their patients well by focusing modality discussions on patients' values and preferences, and the specific physiological considerations described in this chapter.

References and Selected Readings

- Al-Hejaili F, et al. Nocturnal but not short hours quotidian hemodialysis requires an elevated dialysate calcium concentration. *J Am Soc Nephrol*. 2003;14:2322–2328.
- Ayus JC, et al. Effects of short daily versus conventional hemodialysis on left ventricular hypertrophy and inflammatory markers: a prospective, controlled study. *J Am Soc Nephrol*. 2005;16:2778–2788.
- Blagg CR. A brief history of home hemodialysis. *Adv Ren Replace Ther*. 1996;3:99–105.
- Chan CT, et al. Short-term blood pressure, noradrenergic, and vascular effects of nocturnal home hemodialysis. *Hypertension*. 2003;42:925–931.
- Charra B, et al. Long thrice weekly hemodialysis: the Tassin experience. *Int J Artif Organs*. 2004;27:265–283.
- Chertow GM, et al. (for the FHN Trial group). In-center hemodialysis six times per week versus three times per week. *N Engl J Med*. 2010;363:2287–2300.

- Chertow GM, et al.; the FHN Group. Effects of randomization to frequent in-center hemodialysis on long-term mortality: frequent hemodialysis daily trial [abstract FR-PO342]. *J Am Soc Nephrol*. 2013;24:442A.
- Clark WR, Turk JE. The NxStage system one. *Semin Dial*. 2004;17:167–170.
- Culleton BF, et al. Effect of frequent nocturnal hemodialysis vs conventional hemodialysis on left ventricular mass and quality of life: a randomized controlled trial. *JAMA*. 2007;298:1291–1299.
- Daugirdas JT, et al.; the FHN Trial Group. Effect of frequent hemodialysis on residual kidney function. *Kidney Int*. 2013;83:949–958.
- Depner TA. Daily hemodialysis efficiency: an analysis of solute kinetics. *Adv Ren Replace Ther*. 2001;8:227–235.
- Diaz-Buxo JA, Schlaeper C, VanValkenburgh D. Evolution of home hemodialysis monitoring systems. *Hemodial Int*. 2003;7:353–355.
- Gotch FA. The current place of urea kinetic modelling with respect to different dialysis modalities. *Nephrol Dial Transplant*. 1998;13(suppl 6):10–14.
- Heidenheim AP, et al. Patient monitoring in the London daily/nocturnal hemodialysis study. *Am J Kidney Dis*. 2003;42(1 suppl):61–65.
- Hussain SA, et al. Phosphate enriched hemodialysis during pregnancy: two case series. *Hemodial Int*. 2005;9:147–152.
- Ing TS, et al. Phosphorus-enriched hemodialysates: formulations and clinical use. *Hemodial Int*. 2003;7:148–155.
- Muir CA, et al. Buttonhole cannulation and clinical outcomes in a home hemodialysis cohort and systematic review. *Clin J Am Soc Nephrol*. 2014;9:110–119.
- Leitch R, et al. Nursing issues related to patient selection, vascular access, and education in quotidian hemodialysis. *Am J Kidney Dis*. 2003;42(1 suppl):56–60.
- Marshall MR, et al. Home hemodialysis and mortality risk in Australian and New Zealand populations. *Am J Kidney Dis*. 2011;58(5):782–793.
- McFarlane PA. Reducing hemodialysis costs: conventional and quotidian home hemodialysis in Canada. *Semin Dial*. 2004;17:118–124.
- Mucsi I, et al. Control of serum phosphate without any phosphate binders in patients treated with nocturnal hemodialysis. *Kidney Int*. 1998;53:1399–1404.
- Muir CA, et al. Buttonhole cannulation and clinical outcomes in a home hemodialysis cohort and systematic review. *Clin J Am Soc Nephrol*. 2014;9:110–119.
- Mustafa RA, et al. Vascular access for intensive maintenance hemodialysis: a systematic review for a Canadian Society of Nephrology clinical practice guideline. *Am J Kidney Dis*. 2013;62:112–131.
- Nesrallah GE, et al. *Staphylococcus aureus* bacteremia and buttonhole cannulation: long-term safety and efficacy of mupirocin prophylaxis. *Clin J Am Soc Nephrol*. 2010;5:1047–1053.
- Nesrallah GE, et al. Canadian Society of Nephrology guidelines for the management of patients with end stage renal disease treated with intensive hemodialysis. *Am J Kidney Dis*. 2013;62:187–198.
- Pierratos A. Nocturnal home haemodialysis: an update on a 5-year experience. *Nephrol Dial Transplant*. 1999;14:2835–2840.
- Pierratos A. Delayed dialyzer reprocessing for home hemodialysis. *Home Hemodial Int*. 2000;4:51–54.
- Rocco MV et al., (for the FHN Trial Group). The effects of frequent nocturnal home hemodialysis:

the frequent hemodialysis network nocturnal trial. *Kidney Int.* 2011;80:1080–1091.

Rocco MV, et al., the FHN Group. Effects of randomization to frequent nocturnal hemodialysis on long-term mortality: Frequent Hemodialysis Nocturnal Trial [abstract FR-PO345]. *J Am Soc Nephrol.* 2013;24:443A.

Sam R, et al. Using disodium monohydrogen phosphate to prepare a phosphate-enriched hemodialysate. *Hemodial Int.* 2013;17:667–668.

Suri RS, et al. Daily hemodialysis: a systematic review. *Clin J Am Soc Nephrol.* 2006;1:33–42.

Suri RS, et al. Risk of vascular access complications with frequent hemodialysis. *J Am Soc Nephrol.* 2013;24:498–505.

Suri RS, et al. A multinational cohort study of in-center daily hemodialysis and patient survival. *Kidney Int.* 2013;83:300–307.

Trojanov S, et al. Phosphate addition to hemodiafiltration solutions during continuous renal replacement therapy. *Intensive Care Med.* 2004;30:1662–1665.

Walsh M, et al. A systematic review of the effect of nocturnal hemodialysis on blood pressure, left ventricular hypertrophy, anemia, mineral metabolism, and health-related quality-of-life. *Kidney Int.* 2005;67:1501–1508.

Web References

Home dialysis central: <http://www.homedialysis.org>.

ISHD home dialysis handbook: <http://www.ishdn.net>.

Conventional diffusion-based dialysis modalities, including high-flux hemodialysis, are limited in their capacity to effectively remove larger-molecular-weight uremic toxins. Hemodiafiltration (HDF) is a modality that enhances convective solute transport of a broad range of uremic toxins known to be involved in uremia (Vanholder, 2003) and may provide patients with a number of benefits, including improved outcomes.

- I. **DIFFUSION VERSUS CONVECTION-BASED CLEARANCES.** Hemodialysis relies on diffusive transport. The rate of diffusion of the molecules is inversely proportional to the square root of their molecular weight. Larger molecules have a relatively low speed of diffusion and therefore a relatively slow clearance by hemodialysis. Convective transport depends on solvent drag, where molecules, regardless of their molecular weight, are transported across the membrane by bulk fluid flow. The extent to which the solute is taken across the membrane depends on the so-called sieving coefficient, which varies from 0 to 1.0. The sieving coefficient is different for different solutes and also depends on membrane characteristics. Convective transport markedly increases the removal of those middle- and large-sized molecules that are poorly cleared by diffusion-based therapies.
- II. **BASICS OF HEMODIAFILTRATION.** HDF is a “hybrid” therapy combining within the same dialyzer module the two main solute transport mechanisms described above: diffusion and convection.
 - A. **Clearance due to diffusion and convection in HDF.** The total clearance results from the sum of diffusive and convective clearances. For detailed equations, see Table 17.1. Convective clearance for a given solute depends on the total ultrafiltered volume and the solute sieving coefficient for the membrane being used. The total ultrafiltered volume is the sum of the fluid removed during the treatment for the purpose of correcting extracellular fluid overload plus the volume of “replacement or substitution fluid” infused during the treatment for the purpose of enhancing convection.

The EUDIAL group (Tattersall, 2013) has proposed the following equations to describe clearance with HDF.

The diffusive component (K_D) can be estimated as follows:

$$K_D = \frac{1 - e^{K_oA \times [(Q_b - Q_d)/(Q_b \times Q_d)]}}{(1/Q_b) - (1/Q_d) \times e^{K_oA \times [(Q_b - Q_d)/(Q_b \times Q_d)]}}$$

where Q_b is blood flow rate; Q_d is dialysis fluid flow rate; and K_oA is solute-specific dialyzer mass transfer-area coefficient.

The convective component (K_C) can be estimated as follows:

$$K_C = \frac{Q_b - K_D}{Q_b} \times Q_f \times S,$$

where Q_f is the convective flow rate and S is sieving coefficient.

The total clearance K_T can be estimated as the sum of both components as follows:

$$K_T = (K_D + K_C) \times DF$$

in which DF stands for dilution factor, depending on how the replacement fluid is infused during the treatment (postdilution, predilution, or mixed dilution).

-
- B. **Substitution mode: Postdilution, predilution, and mixed dilution.** Infusing the substitution fluid solution in postdilution mode (Fig. 17.1) means that the fluid is added to the blood flow stream as it exits the hemodialyzer. This is the most efficient option for solute clearances (Fig. 17.1) because there is no dilution of blood in the dialyzer, where convection is occurring. However, when blood flow rate is limited, or when adverse hemorheological conditions (such as high hemoglobin or high protein concentration) are present, or when the rate of substitution fluid infusion needs to be quite high, to avoid hemoconcentration in the filter, one can infuse all of the replacement fluid (predilution mode, Fig. 17.2) or a part of it (mixed dilution, Fig. 17.3) into the blood line upstream to the filter (Pedrini, 2003). The predilution and mixed-dilution modes reduce solute clearance considerably because the concentration of toxins in the blood entering the dialyzer is diluted by the substitution fluid. Advantages and disadvantages of each substitution fluid infusion mode are given in Table 17.2.

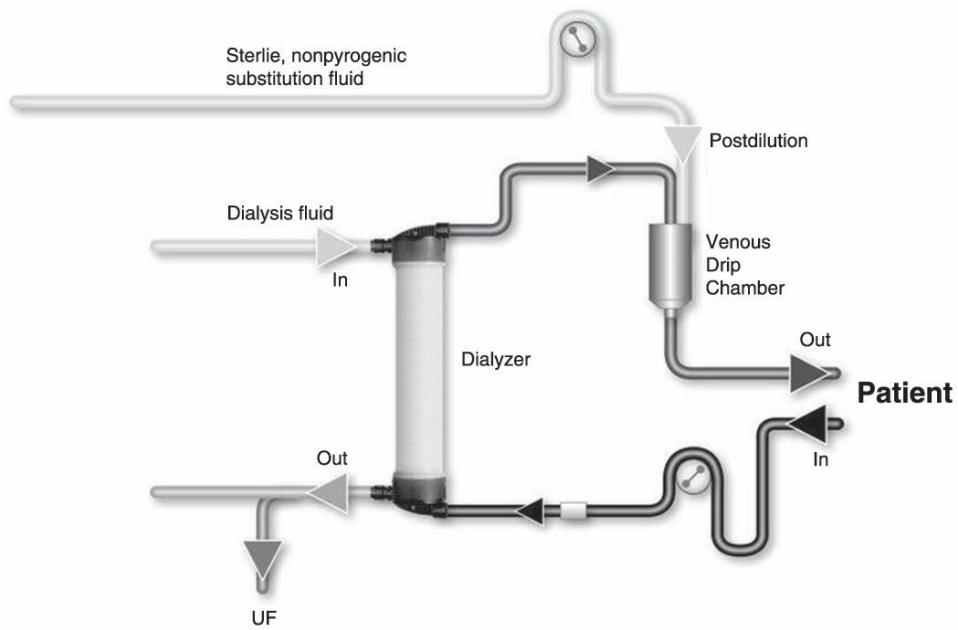

FIGURE 17.1 Postdilution online hemodiafiltration.

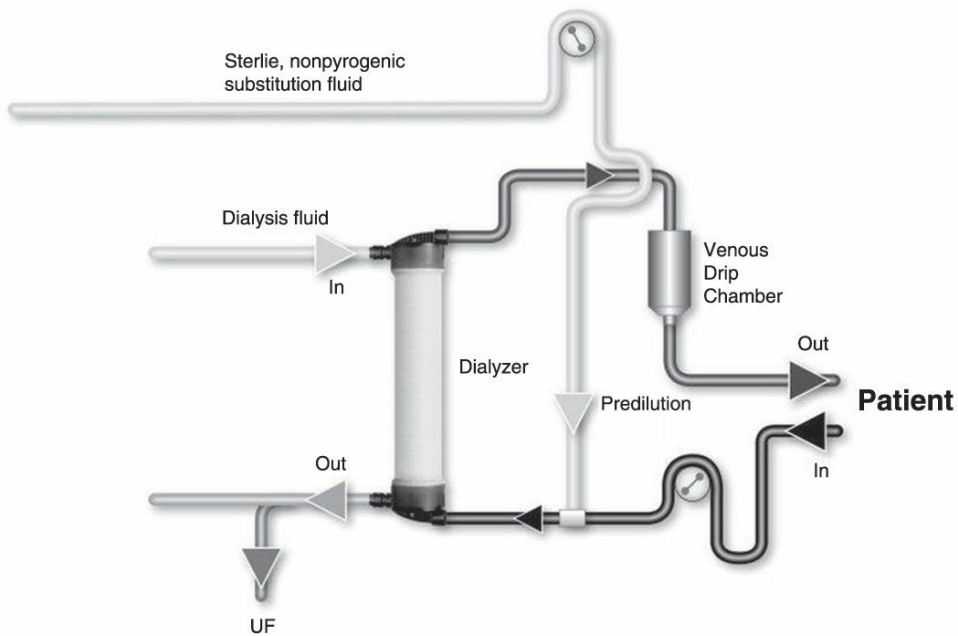

FIGURE 17.2 Predilution online hemodiafiltration.

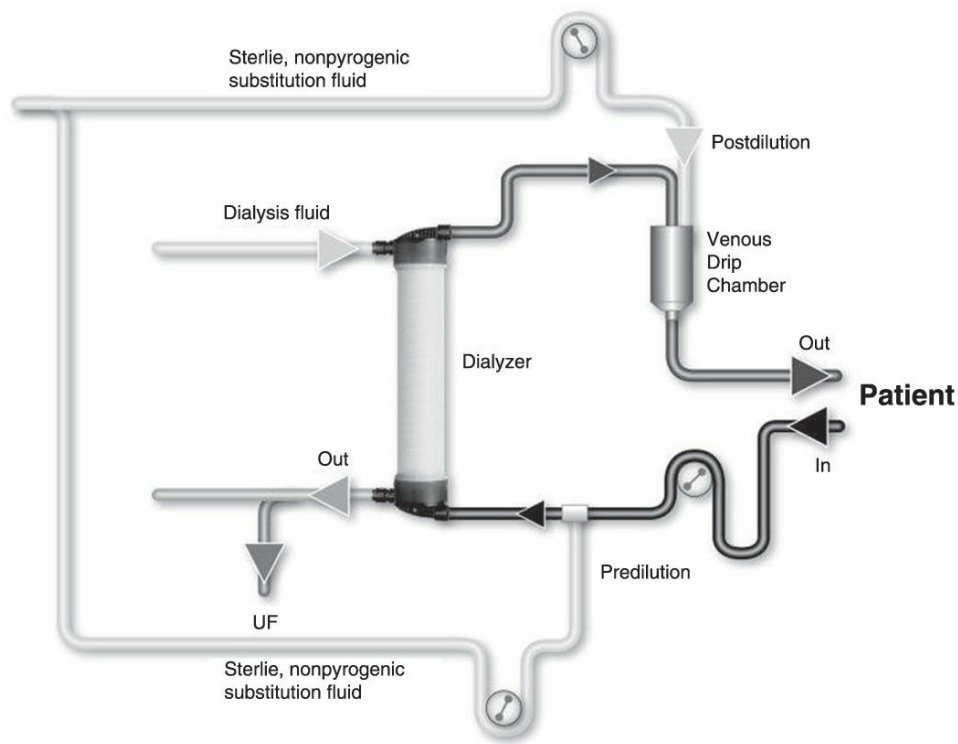

FIGURE 17.3 Mixed-dilution online hemodiafiltration.

TABLE

17.2

Advantages and Shortcomings of Each of HDF Modalities

Postdilution	Predilution	Mixed Dilution
Pros		
<ul style="list-style-type: none"> • High solute clearance and removal of small-, middle-, and high-molecular-weight solutes • Reduced volume of substitution fluid relative to the other modalities 	<ul style="list-style-type: none"> • Hemodilution <ul style="list-style-type: none"> – Decrease in protein and hematocrit – Reduced viscosity and oncotic pressure – Reduced fiber and membrane fouling – Permits HDF with suboptimal blood flow or unfavorable hemorheological conditions • Facilitates protein-bound solute clearance and removal • Preserves hydraulic and solute membrane permeability (reduces membrane stress) 	<ul style="list-style-type: none"> • Avoids drawbacks of both post- and predilution methods • Permits HDF under suboptimal blood flow conditions and unfavorable hemorheological conditions
Cons		
<ul style="list-style-type: none"> • Hemoconcentration <ul style="list-style-type: none"> – Increase in protein and hematocrit – Increase in viscosity and oncotic pressure – Potential membrane fouling • Reduced hydraulic and solute membrane permeability – Increase in transmembrane 	<ul style="list-style-type: none"> • Reduced solute clearance and removal of small-, middle-, and high-molecular-weight solutes • Increased volume of substitution fluid 	<ul style="list-style-type: none"> • Require specific hardware equipment <ul style="list-style-type: none"> – Two infusion pumps – Specific blood tubing set • Requires specific software and algorithm <ul style="list-style-type: none"> – Accounting for hematocrit and protein changes

pressure	needed (twofold)	– Adjusting post-/preinfusion ratio, keeping transmembrane pressure in target range
– Reduced sieving coefficient		– Increased volume of substitution fluid (only 1.3-fold)
– Fiber clotting		
– Potential alarms		
– Increased membrane stress		
– Potential albumin leakage		

C. Technical issues

1. **Vascular access.** Patients treated with HDF require a vascular access capable of delivering an extracorporeal blood flow of at least 350–400 mL/min on a reliable basis.
2. **High-flux hemodiafilter.** The semipermeable membrane should have a high hydraulic permeability (KUF >50 mL per hour per mm Hg), high solute permeability (sieving coefficient for β_2 -microglobulin >0.6), and an optimal surface area of exchange (1.60–1.80 m²). Further, low internal blood resistance (internal fiber diameter >200 micrometers, sufficient number of fibers; length of fiber bundle <30 cm) is highly desirable to reduce hemoconcentration and facilitate ultrafiltration.
3. **Online production of substitution fluid.** Outside of the United States, most dialysis machine manufacturers provide an upgrade option enabling direct production of substitution fluid for intravenous infusion from dialysis solution (Blankestijn, 2010). Such online techniques enable provision of virtually unlimited amounts of sterile nonpyrogenic substitution fluid at a relatively low cost. All studies have shown that online production of substitution fluid is a safe, reliable, and economically viable solution for routine clinical application (Canaud, 2000). This approach has gained the approval of all European regulatory bodies operating under the European Community label.

The production of sterile and nonpyrogenic dialysis fluid (ultrapure dialysate) is achieved by “cold sterilization” of the freshly prepared dialysis solution using dedicated sterilizing ultrafilters. The infusion module consists of an adjustable infusion pump that can be set to operate at 0–250 mL/minute. The ultrapure dialysate produced in this manner is then diverted by the infusion pump and passed through a second ultrafilter. The doubly filtered substitution fluid is then infused into the patient’s blood. The sterilizing ultrafilters are incorporated in the dialysis fluid paths and are disinfected in situ within the machine. They need to be replaced periodically according to defined criteria (either number of sessions or duration of use) to prevent loss of their endotoxin adsorption capacity.

4. **Water quality.** Water used for convection-based therapies needs to comply with very stringent criteria of purity. Such high refinement in water purification has led to the concept of “ultrapure water”—virtually sterile and nonpyrogenic water. The overall target of this concept is to ensure both the chemical and microbiological purity of all fluids used. Technical aspects of water treatment systems and water distribution piping systems have been detailed elsewhere. The basic technical options required to produce ultrapure water consists of a pretreatment system (microfiltration, softeners, activated

carbon, downstream microfiltration) that is followed by two reverse osmosis modules in series. Ultrapurified water is delivered to dialysis machines via a distribution loop that ensures continuous recirculation of water. As already described, microbiological-quality dialysis fluid is derived from this chemically pure water by using downstream sterilizing ultrafilters incorporated within the dialysis machine.

5. **Quality assurance and hygienic rules.** A quality assurance process is required to maintain, on a regular basis, the ultrapurity of water produced and delivered to all HDF machines. This implies regular disinfection of the water treatment system (chemical and/or thermal) and microbiological monitoring of the produced water (bacteriometry using appropriate methods and assessment of endotoxin content based on *Limulus* amoebocyte lysate [LAL] assay). In addition, online HDF machines are submitted to regular disinfection, changes of sterilizing ultrafilters, and microbiological monitoring according to manufacturer recommendations and local regulations.

III. PRESCRIPTION OF HDF. In chronic kidney disease patients, conventional HDF treatment schedules are based on three dialysis sessions per week each of 4 hours duration (12 hours per week). A discussion of more frequent or extended treatment schedules is not within the scope of this chapter.

- A. **Ultrafiltered volume.** To derive the full benefits from HDF therapy, the total ultrafiltered volume in postdilution mode, a surrogate of convective dose, should be targeted to 20–24 L per session (85–90 mL/kg per hour) (Canaud, 2006; Bowry, 2013). To achieve in predilution mode an equivalent convective dose, the targeted ultrafiltration volume should be multiplied by 2, or in mixed-dilution mode, the volume should be multiplied by 1.3.
- B. **Electrolyte composition.** Electrolyte prescription is crucial, particularly when a high volume of replacement fluid is used. The electrolyte composition of dialysis fluids needs to be individualized on the basis of the clinical situation. Dialysate sodium concentration can be aligned with the patient predialysis plasma sodium concentration to reduce osmotic gradient shift and to facilitate removal of excess sodium. Dialysate potassium concentration should be preferably between 2 and 4 mM. Dialysate calcium, depending on targeted calcium mass balance, should be in the range of 1.25–1.50 mM (2.5–3.0 mEq/L) to ensure a neutral or minimally positive calcium balance. Higher calcium concentration (1.75 mM or 3.5 mEq/L) use should be restricted to severe hypocalcemia and particular indications (e.g., hypoparathyroidism, calcimimetic use). The typical dialysate magnesium concentration is 0.50 mM (1.0 mEq/L). Dialysate bicarbonate concentration (measured after reaction with acid concentrate) should be preferably in the range of 28–30 mM, considering the additional alkalinizing effect of the acetate (4–8 mM) or citrate (0.8–1.0 mM, 2.4–3.0 mEq/L) that is also commonly present in the final dialysis/replacement solution.
- C. **Anticoagulation.** HDF may result in higher blood procoagulatory activity when compared with standard hemodialysis owing to forced ultrafiltration and potential loss of anticoagulant. Administration of low-molecular-weight heparin and to a lesser extent unfractionated heparin via the arterial line results in a significant clearance of heparin, because HDF may remove this size range of molecules. Heparin should not be given as a bolus into the

hemodiafilter inlet blood line, because up to 50% of unfractionated heparin or 80% of low-molecular-weight heparin can be removed on first passage through a high-efficiency HDF setup (this phenomenon occurs only at the “first passage” when heparin is not bound to antithrombin or protein. It is not true afterward when heparin has mixed with the blood and has become bound to antithrombin). Instead, the initial heparin bolus dose should be infused via the venous needle or blood line and allowed to mix with the patient’s blood for at least 3–5 minutes before initiating extracorporeal blood flow. The dose of heparin needed can vary widely from patient to patient and requires a stepwise, titration-based increase. Failure to achieve adequate ultrafiltration or clotting within the circuit usually responds to an increase in the heparin dose. Dose adjustment protocols need to be based on an assessment of the bleeding risk, patency of the extracorporeal circuit, and type of heparin used.

IV. CLINICAL BENEFITS OF CONVECTIVE THERAPIES

A. Solute removal

1. **Clearance of middle molecules.** Several prospective controlled studies have confirmed enhanced clearance and mass removal of β_2 -microglobulin in HDF (30–40% higher than high-flux hemodialysis) accompanied by a 10–20% decline of circulating blood β_2 -microglobulin concentrations (Ward, 2000; Maduell, 2002; Lornoy, 2006; Pedrini, 2011). When one acknowledges the predictive value of β_2 -microglobulin concentrations on morbidity and mortality in hemodialysis patients, it appears crucial to target lower circulating levels of this uremic toxin when considering dialysis adequacy (Cheung, 2006).
2. **Clearance of phosphate.** In HDF, phosphate mass removal is enhanced by 15–20% (Lornoy, 2000). In one large study, predialysis serum phosphate levels with HDF were reduced by 6%, and the percentage of patients reaching target pretreatment serum phosphorus levels increased from 64 to 74% (Penne, 2010).
3. **Other substances.** High removal rates of a number of other substances considered as uremic toxins have been documented using HDF, including complement factor D (a proinflammatory mediator), leptin (16 kDa; effective removal of leptin may favor the improvement of patient nutritional status), FGF23 (30 kDa, mediator implicated in metabolic bone disorders and vascular calcification), and various cytokines, erythropoiesis inhibitors such as 3-carboxy-4-methyl-5-propyl-2-furanpropionic acid (CMPF), immunoglobulin light chains (κ , λ) and circulating advanced glycosylation end products (AGEs), and AGE precursors (Chun-Liang, 2003; Stein, 2001).

B. Clinical comparisons of HDF versus hemodialysis.

1. **Intradialytic symptoms.** With HDF, some studies have shown a substantial reduction in intradialytic hypotensive episodes compared with conventional hemodialysis. This beneficial effect has been ascribed to negative thermal balance (due to infusion of relatively cool replacement fluid), a high sodium concentration of the substitution fluid, and/or removal of vasodilating mediators (Van der Sande, 2001). By reducing repetitive ischemic cardiac insults, HDF may have a cardioprotective effect (Ohtake,

2012). In one study in which HDF was compared with hemodialysis with similar extracorporeal heat transfer rates, no benefit in terms of better blood stability could be demonstrated, illustrating the potential importance of the temperature factor (Kumar, 2013).

2. **Residual renal function.** Several small, observational studies (following fewer than 60 patients) have suggested that HDF contributes to a longer and better preservation of residual renal function than conventional HD (Schiffl, 2013). The larger randomized comparisons of HDF with hemodialysis have not reported on this. If true, the beneficial effect might be due to reduction of microinflammation and to prevention of repetitive renal ischemic insults due to intradialytic hypotension.
 3. **Lower inflammatory profile.** On the basis of sensitive biomarkers of the acute-phase reaction (C-reactive protein, various interleukins), several prospective studies have shown that the behavior of these markers is reduced with HDF relative to conventional hemodialysis (Susantitaphong, 2013).
 4. **Anemia correction and erythropoiesis stimulating agent (ESA) consumption.** Various meta-analyses suggest that HDF does not have a major impact on ESA dose (Susantitaphong, 2013), although a positive effect should logically be present owing to better removal of erythropoietic inhibitor substances and/or to a reduction of inflammation. In some studies where ESA dose has been reduced, the benefit may be related to the use of advanced dialysis technology with higher-quality water and dialysis solution associated with HDF.
 5. **Malnutrition.** Most studies did not find significant changes in anthropometric parameters, or protein markers of nutrition (albumin, prealbumin) in patients treated with enhanced convective therapies. Several studies did report an improvement in appetite.
 6. **Dyslipidemia and oxidative stress.** The regular use of enhanced convective therapies has been shown to improve lipid profile, to reduce serum markers of oxidative stress, and to lower serum AGE concentrations. Such beneficial effects may be partly due to the improved overall biocompatibility of the dialysis system preventing inflammation and carbonyl stress, and, more speculatively, to the removal of pro-oxidative uremic toxins.
 7. **α_2 -microglobulin amyloidosis.** Several large cohort studies indicate that the extended use of high-flux membranes and convective therapies have a beneficial impact on the development of β_2 -microglobulin amyloidosis, reducing the incidence of carpal tunnel syndrome. This beneficial effect probably results from the regular use of ultrapure water and biocompatible material that prevents inflammation combined with convective modalities that enhance β_2 -microglobulin removal (Schiffl, 2014).
- C. **Morbidity and mortality benefits.** Three randomized trials comparing survival and hospitalizations in patients treated with HDF versus patients treated with either high-flux or low-flux hemodialysis have been performed, each with about 700–900 patients. An initial study (Ok, 2013) failed to find a difference in survival, hospitalization rates, or incidence of intradialytic hypotension. The mean ultrafiltration volume (substitution fluid volume plus excess volume removed) in that study was about 19.5 L, and a post hoc analysis showed better survival in patients in whom higher substitution fluid volumes had

been used. Two subsequent prospective randomized trials (CONTRAST and ESHOL) in which the mean ultrafiltration volumes were somewhat higher came to different conclusions. In CONTRAST (Grooteman, 2012), the mean ultrafiltration volume was 21 L, and a substantial lowering of serum β_2 -microglobulin was achieved relative to the control group that was treated with low-flux hemodialysis. However, there was no difference between HDF and the hemodialysis group in terms of survival or hospitalizations. In the ESHOL study (Maduell, 2013), the mean average ultrafiltration volume was about 23–24 L, and the comparison group was treated with high-flux dialysis. Here, the result was markedly different; the group treated with HDF showed a 30% reduction in all-cause mortality. Thus, the effect of HDF on survival is at present a matter of some uncertainty. It remains possible that relatively high doses of HDF are required to show an improvement in mortality. In all three studies, there was a trend for a reduction in cardiovascular mortality in the patients treated with HDF (Mostovaya, 2014).

V. ISSUES TO BE CONSIDERED WHEN APPLYING CONVECTIVE MODALITIES

- A. **Dialysate/water quality.** In case of cold sterilization failure of replacement fluid or inadequate disinfection of HDF machines, the potential adverse effects of bacterial-derived products (endotoxin, peptidoglycans, bacterial DNA) entering the bloodstream is an important consideration. By applying strict hygienic rules of disinfection to the HDF machine, stringent microbial monitoring, and regular replacement of sterilizing ultrafilters, such risks should be minimized. It is good clinical practice to monitor clinical symptomatology of HDF-treated patients and to measure blood CRP using a sensitive assay on a regular basis.
- B. **Protein loss.** The use of highly permeable membranes subjected to high transmembrane pressure may lead to increased albumin loss. Improvement of membrane manufacturing technology has reduced the sieving coefficient for albumin in commonly used HDF membranes to a very low number (<0.001). Higher-molecular-weight cutoff membranes that do leak albumin are not a good option for HDF and expose the patient to risk of significant albumin loss. There is one school of thought that some albumin loss during hemodialysis may be a good thing, as it serves to increase the removal of albumin-bound uremic toxins (Niwa, 2013), but the benefits of such protein-leaking membranes is still being debated.
- C. **Deficiency syndromes.** Enhanced loss of nutrients is a theoretical risk associated with all modalities that use high-flux membranes. Soluble vitamins, trace elements, amino acids, small peptides, and proteins may be lost. The amount lost per session is low and in most cases can be compensated for by adequate oral intake (Morena, 2002; Cross and Davenport, 2011). The role of vitamin supplementation in high flux treatments is discussed in Chapters 31 and 34.

VI. **ALTERNATIVE CONVECTIVE METHODS.** Other variants include pure hemofiltration, mid-dilution HDF, push/pull HDF, double high-flux hemodialysis, and paired HDF. Their description is beyond the scope of the *Handbook*.

References and Suggested Reading

- Altieri P, et al. Predilution hemofiltration, the Second Sardinian Multicenter Study: comparisons between hemofiltration and haemodialysis during identical Kt/V and session times in a long-term cross-over study. *Nephrol Dial Transplant*. 2001;16:1207–1213.
- Blankestijn PJ, Ledebro I, Canaud B. Hemodiafiltration: clinical evidence and remaining questions. *Kidney Int*. 2010;77:581–587.
- Bowry SK, Canaud B. Achieving high convective volumes in on-line hemodiafiltration. *Blood Purif*. 2013;35(suppl 1):23–28.
- Canaud B, Bowry SK. Emerging clinical evidence on online hemodiafiltration: does volume of ultrafiltration matter? *Blood Purif*. 2013;35:55–62.
- Canaud B, et al. On-line haemodiafiltration: safety and efficacy in long-term clinical practice. *Nephrol Dial Transplant*. 2000;15(suppl 1):60–67.
- Canaud B, et al. Mortality risk for patients receiving hemodiafiltration versus hemodialysis: European results from the DOPPS. *Kidney Int*. 2006;69:2087–2093.
- Cheung AK, et al. Serum beta-2 microglobulin levels predict mortality in dialysis patients: results of the HEMO study. *J Am Soc Nephrol*. 2006;17:546–555.
- Chun-Liang L, et al. Reduction of advanced glycation end products levels by on-line hemodiafiltration in long-term hemodialysis patients. *Am J Kidney Dis*. 2003;42:524.
- Cross J, Davenport A. Does online hemodiafiltration lead to reduction in trace elements and vitamins? *Hemodial Int*. 2011;15:509–14.
- European Best Practice Guidelines (EBPG) Expert Group on Hemodialysis, European Renal Association: Section II. Haemodialysis adequacy. *Nephrol Dial Transplant*. 2002;17(suppl 7):16.
- Grooteman MP, et al; CONTRAST Investigators. Effect of online hemodiafiltration on all-cause mortality and cardiovascular outcomes. *J Am Soc Nephrol*. 2012;23: 1087–1096.
- Jirka T, et al. Mortality risk for patients receiving hemodiafiltration versus hemodialysis. *Kidney Int*. 2006;70:1524
- Kumar S, et al. Haemodiafiltration results in similar changes in intracellular water and extracellular water compared to cooled haemodialysis. *Am J Nephrol*. 2013;37:320–324.
- Locatelli F, Canaud B. Dialysis adequacy today: a European perspective. *Nephrol Dial Transplant*. 2012;27:3043–3048.
- Locatelli F, et al. Hemofiltration and hemodiafiltration reduce intradialytic hypotension in ESRD. *J Am Soc Nephrol*. 2010;21:1798–1807.
- Lornoy W, et al. On-line haemodiafiltration. Remarkable removal of beta2-microglobulin: long-term clinical observations. *Nephrol Dial Transplant*. 2000;15(suppl 1):49.
- Lornoy W, et al. Impact of convective flow on phosphorus removal in maintenance hemodialysis patients. *J Ren Nutr*. 2006;16:47–53.
- Maduell F, et al. Osteocalcin and myoglobin removal in on-line hemodiafiltration versus low-and high-flux hemodialysis. *Am J Kidney Dis*. 2002;40:582–589.
- Maduell F, et al; ESHOL Study Group. High-efficiency postdilution online hemodiafiltration reduces all-cause mortality in hemodialysis patients. *J Am Soc Nephrol*. 2013;24:487–497.
- Morena M, et al. Convective and diffusive losses of vitamin C during haemodiafiltration session: a contributive factor to oxidative stress in haemodialysis patients. *Nephrol Dial Transplant*. 2002;17:422.

- Mostovaya IM, et al on behalf of EUDIAL—an official ERA-EDTA Working Group. Clinical evidence on hemodiafiltration: a systematic review and a meta-analysis. *Semin Dial.* 2014;27:119–127.
- Nistor I, et al. Convective versus diffusive dialysis therapies for chronic kidney failure: an updated systematic review of randomized controlled trials. *Am J Kidney Dis.* 2014;63:954–67.
- Niwa T. Removal of protein-bound uraemic toxins by haemodialysis. *Blood Purif.* 2013;35 Suppl 2:20–5.
- Ohtake T, et al. Cardiovascular protective effects of on-line hemodiafiltration: comparison with conventional hemodialysis. *Ther Apher Dial.* 2012;16:181–188.
- Ok E, et al; Turkish Online Haemodiafiltration Study. Mortality and cardiovascular events in online haemodiafiltration (OL-HDF) compared with high-flux dialysis: results from the Turkish OL-HDF Study. *Nephrol Dial Transplant.* 2013;28: 192–202.
- Panichi V, et al; RISCAVID Study Group. Chronic inflammation and mortality in haemodialysis: effect of different renal replacement therapies. Results from the RISCAVID study. *Nephrol Dial Transplant.* 2008;23:2337–2343.
- Pedrini LA, De Cristofaro V. On-line mixed hemodiafiltration with a feedback for ultrafiltration control: effect on middle-molecule removal. *Kidney Int.* 2003;64:1505.
- Pedrini LA, et al. Long-term effects of high-efficiency on-line haemodiafiltration on uraemic toxicity: a multicentre prospective randomized study. *Nephrol Dial Transplant.* 2011;26:2617–2624.
- Penne EL, et al; CONTRAST Investigators. Short-term effects of online hemodiafiltration on phosphate control: a result from the randomized controlled Convective Transport Study (CONTRAST). *Am J Kidney Dis.* 2010;55:77.
- Schiffl H. Impact of advanced dialysis technology on the prevalence of dialysis-related amyloidosis in long-term maintenance dialysis patients. *Hemodial Int.* 2014;18:136–141.
- Schiffl H, Lang SM, Fischer R. Effects of high efficiency post-dilution on-line hemodiafiltration or conventional hemodialysis on residual renal function and left ventricular hypertrophy. *Int Urol Nephrol.* 2013;45:1389–1396.
- Stein G, et al. Influence of dialysis modalities on serum AGE levels in end-stage renal disease patients. *Nephrol Dial Transplant.* 2001;16:999.
- Susantitaphong P, Siribamrungwong M, Jaber BL. Convective therapies versus low-flux hemodialysis for chronic kidney failure: a meta-analysis of randomized controlled trials. *Nephrol Dial Transplant.* 2013;28:2859–2874.
- Tattersall JE, Ward RA; EUDIAL group. Online haemodiafiltration: definition, dose quantification and safety revisited. *Nephrol Dial Transplant.* 2013;28:542–550.
- Van der Sande FM, et al. Thermal effects and blood pressure response during postdilution hemodiafiltration and hemodialysis: the effect of amount of replacement fluid and dialysate temperature. *J Am Soc Nephrol.* 2001;12:1916.
- van der Weerd NC, et al. Haemodiafiltration: promise for the future? *Nephrol Dial Transplant.* 2008;23:438–443.
- Vanholder R, et al. Back to the future: middle molecules, high flux membranes, and optimal dialysis. *Hemodial Int.* 2003;7:52.
- Vilar E, et al. Long-term outcomes in online hemodiafiltration and high-flux hemodialysis: a comparative analysis. *Clin J Am Soc Nephrol.* 2009;4:1944–1953.

Wang AY, et al. Effect of hemodiafiltration or hemofiltration compared with hemodialysis on mortality and cardiovascular disease in chronic kidney failure: a systematic review and meta-analysis of randomized trials. *Am J Kidney Dis*. 2014;63:968–78.

Ward RA, et al. A comparison of on-line hemodiafiltration and high-flux hemodialysis: a prospective clinical study. *J Am Soc Nephrol*. 2000;11:2344.

Therapeutic apheresis (TA) refers to a group of extracorporeal procedures in which blood separation technology is used to remove abnormal blood cells and/or plasma constituents. The terms plasmapheresis, leukapheresis, erythrocytapheresis, and thrombocytophoresis describe the specific blood element that is removed. In plasmapheresis, or therapeutic plasma exchange (TPE), large quantities of plasma are removed from a patient and replaced with fresh frozen plasma (FFP), or albumin solutions in normal saline.

I. RATIONALE FOR PLASMAPHERESIS (TPE). There are several mechanisms by which plasmapheresis exerts its beneficial effects (Table 18.1). Its major mode of action is rapid depletion of specific disease-associated factors. Another effect is its ability to remove other high-molecular-weight proteins that may participate in the inflammatory process (intact complement C3, C4, activated complement products, fibrinogen, and cytokines). Several other theoretical effects of TPE on immune function have been proposed, including immunomodulatory actions such as alterations in idiotypic/anti-idiotypic antibody balance, a shift in the antibody-to-antigen ratio to more soluble forms of immune complexes (facilitating their clearance), and stimulation of lymphocyte clones to enhance cytotoxic therapy. TPE also allows the infusion of normal plasma, which may replace a deficient plasma component, perhaps the principal mechanism of action of TPE in thrombotic thrombocytopenic purpura (TTP).

A. Principles of treatment

- 1. Use of concomitant immunosuppression.** Because of the immunologic nature of most diseases treated by plasmapheresis, therapy should almost always include concomitant immunosuppression. Adjunct medication protocols usually include high doses of corticosteroids, cytotoxic drugs, and biologic agents. These medications are expected to reduce the rate of resynthesis of pathologic antibodies and to further modulate cell-mediated immunity, which may contribute to many of these disorders.
- 2. Early treatment.** Diseases that respond to plasmapheresis are best treated early to halt the inflammatory response that often contributes to disease progression. For example, plasmapheresis of anti-glomerular basement membrane (GBM) disease is most effective if therapy is initiated when serum creatinine is <5 mg/dL (440 μ mol/L).

Removal of Abnormal Circulating Factor

Antibody (anti-GBM disease, myasthenia gravis, Guillain–Barré syndrome)

Monoclonal protein (Waldenström macroglobulinemia, myeloma protein)

Circulating immune complexes (cryoglobulinemia, SLE)

Alloantibody (Rh alloimmunization in pregnancy)

Toxic factor

Replenishment of Specific Plasma Factor

TTP

Other Effects on the Immune System

Improvement in function of reticuloendothelial system

Removal of inflammatory mediators (cytokines, complement)

Shift in antibody-to-antigen ratio, resulting in more soluble forms of immune complexes

Effects on the cellular immune system

GBM, glomerular basement membrane; SLE, systemic lupus erythematosus; TTP, thrombotic thrombocytopenic purpura.

II. PHARMACOKINETICS OF IMMUNOGLOBULIN (IG) REMOVAL

- A. **Plasma half-life.** Immunoglobulins have relatively long half-lives, approaching 21 days for IgG and 5 days for IgM. Because of the relatively long plasma half-lives of the immunoglobulins, the use of immunosuppressive agents that decrease their production rate cannot be expected to lower the plasma levels of a pathogenic autoantibody for at least several weeks, even if production is completely blocked. This is the basic rationale for their removal by extracorporeal means.
- B. **Extravascular distribution and equilibration rate.** Immunoglobulins have a substantial extravascular distribution (Table 18.2). The extent of intravascular versus extravascular distribution will determine how effectively they can be removed in the course of a single plasmapheresis session. Immunoglobulins exhibit an intravascular-to-extravascular equilibration that is approximately 1%–2% per hour, whereas extravascular-to-intravascular equilibration may be somewhat faster because it is governed by the rate of lymphatic flow. Still, since the extravascular-to-intravascular equilibration is relatively slow, the kinetics of immunoglobulin removal by plasma exchange can be calculated by using first-order kinetics governing removal rates from a single compartment (the intravascular space).

Substance	Molecular Weight	% Intravascular	Half-life (days)	Normal Serum Concentration (mg/dL)
Albumin	69,000	40	19	3,500–4,500
IgG	180,000	45	21	640–1430
IgA	150,000	50	6	30–300
IgM	900,000	80	5	60–350
LDL-cholesterol (β-lipoprotein)	1,300,000	100	3–5	140–200

C. **The macromolecule reduction ratio and V_e/V_p .** In Chapter 3, the relationship between the urea reduction ratio (URR) and Kt/V was described. A similar relationship holds for removal of immunoglobulins by TPE.

The kinetics of immunoglobulin removal by TPE follows an exponential relationship:

$$C_t = C_0 e^{-V_e/V_p}$$

where C_0 = the initial plasma concentration of the macromolecule in question, C_t = its concentration at time t , V_e = the volume of plasma exchanged at time t , and V_p = the estimated plasma volume, which, while smaller than the volume of distribution of many of these macromolecules, functions as the volume from which they are removed, given the slow rate of equilibration between the extravascular and intravascular compartments.

The macromolecule reduction ratio (*MRR*), expressed as a percentage, is $100 \times (1 - C_t/C_0)$, so $MRR = 100 \times (1 - e^{-V_e/V_p})$. If we plug in numbers for V_e from 1,400 mL to 8,400 mL (Table 18.3), and if we assume that a patient's V_p is 2,800 mL, we will get values of V_e/V_p from 0.5 to 3.0. TPE using these V_e/V_p ratios will result in values for the *MRR* (Table 18.3) ranging from 39% (when $V_e/V_p = 0.5$) to 95% (when $V_e/V_p = 3.0$). Note that for $V_e/V_p = 1.0$, the *MRR* is 63%. The largest decrease (*MRR*) occurs with removal of the first plasma volume; removal of subsequent plasma volumes during the same session becomes progressively less effective in decreasing the concentration of the macromolecule in question. The effectiveness of the procedure after one plasma volume is further reduced because of the dilution of the substance to be removed by the exchange fluid. For this reason, usually 1.0–1.5 plasma volume equivalents (V_e/V_p) are exchanged during a plasmapheresis session.

TABLE

18.3

Relationship between Plasma Volume Removed and Concentration of Substance

Portion of Plasma Volume ^a Exchanged (V_e/V_p)	Volume Exchanged (V_e , mL)	Immunoglobulin or Other Substance Removed (<i>MRR</i> , %)
0.5	1,400	39
1.0	2,800	63
1.5	4,200	78
2.0	5,600	86
2.5	7,000	92
3.0	8,400	95

V_e , volume of plasma exchanged; V_p , estimated plasma volume; MRR, macromolecule reduction ratio.

^aPlasma volume = 2,800 mL in a 70-kg patient, assuming hematocrit = 45%.

- D. **Reaccumulation.** Subsequent to the removal of the macromolecule in question, there is a reaccumulation of its concentration in the vascular space from two sources: redistribution and further synthesis. Redistribution from the extravascular space occurs via lymphatic drainage into the vascular space, as well as from diffusion of the macromolecule across capillaries from the interstitial to the intravascular space. Endogenous synthesis has been documented in Goodpasture syndrome, in which the anti-GBM antibodies will be predictably lowered by a given plasma exchange treatment, but intertreatment increases in serum levels are too rapid to be compatible with simple re-equilibration from extravascular stores.
- E. **Pharmacokinetic basis for TPE prescriptions.** Based on these concepts, a rational approach to prescribing TPE is generally to recommend one plasma volume exchange daily or every other day, depending on the disease process, to allow time for adequate redistribution of macromolecules via lymphatic drainage into the vascular space. The rate of accumulation and the frequency of TPE should be targeted to the specific macromolecule that is pathogenic, if this is known. For example, whereas the half-life of IgG is approximately 21 days, that of IgM and IgA is much shorter (5–7 days). Therefore, if the macromolecule in question is IgM, there may be a role for a more extended period of TPE because the endogenous synthesis rate is expected to be higher for IgM than for IgG. In addition, the distribution of IgM is predominantly intravascular, while the distribution of IgG is mainly in the extravascular space. Therefore, when removing IgM antibodies or paraproteins, daily TPE is warranted. On the other hand, patients with presumed IgG autoantibodies should be treated every other day to allow for IgG redistribution from the extravascular space into the intravascular compartment. If the substance to be removed is measurable by reliable quantitative means (such as with specific autoantibody), then the treatment schedule should be designed to achieve a significant reduction of that substance based on kinetic considerations. If treatments are performed without identification of the offending agent, then the physician remains dependent on empirical treatment regimens.
- F. **Estimation of plasma volume.** An estimate of the plasma volume is required to arrive at an appropriate plasmapheresis prescription. For this purpose, there are several nomograms and equations using height, weight, and hematocrit (Hct). These have been incorporated into newer versions of plasmapheresis equipment. A useful rule of thumb is to consider plasma volume to be approximately 35–40 mL/kg of lean body weight, with the lower number (35 mL/kg) applicable to patients with normal Hct values and 40 mL/kg applicable to patients with Hct values that are less than normal. For example, in a 70-kg patient with a normal Hct (45%), plasma volume (V_p) would be $70 \times 40 = 2,800$ mL.

Predicted blood volume equations have been derived by curve-fitting techniques using subjects' height (cm) and body weight (kg) compared with actual blood volumes measured by isotope (iodine-131 albumin) dilution techniques: $V_p = (1 - \text{Hct}) (b + cW)$, where $W =$

lean body weight, $b = 1,530$ for males, 864 for females, and $c = 41$ for males, 47.2 for females. It is important to remember that these calculations are based on lean body weight. Therefore, for obese patients one must use lean body mass to avoid unnecessary and dangerously large volume exchanges.

III. **TECHNICAL CONSIDERATIONS.** TPE can be performed using centrifugation blood cell separators or by membrane plasma separation (MPS). Centrifugation devices are commonly used for blood banking since they are capable of selective cell removal (cytapheresis) in addition to plasmapheresis. MPS utilizes highly permeable hollow-fiber filters, similar to dialyzers but with large pore sizes and appropriately modified dialysis equipment. The advantages and disadvantages of each technique are summarized in Table 18.4.

A. **Centrifugal apheresis.** During centrifugation, blood cells are separated by gravity, based on the different densities of the blood components. There are two centrifugation methods used in blood cell separators: **intermittent-flow** (or discontinuous-flow) devices and **continuous-flow** devices. Red blood cells (RBCs) move to the outside of the spinning container, while plasma, the lightest component, remains on the inside. Platelets and white blood cells (WBCs) localize between the red cell and plasma layers. Any of these components can be collected, discarded, or reinfused (Fig. 18.1).

TABLE
18.4 Comparison of Membrane Plasma Separation and Centrifugal Apheresis

	Advantages	Disadvantages
Membrane plasma separation	<ul style="list-style-type: none"> Faster and smaller equipment No citrate requirements Can be adapted for cascade filtration 	<ul style="list-style-type: none"> Removal of substances limited by sieving coefficient of membrane Reduced efficiency in hyperviscosity syndromes and cryoglobulinemia Unable to perform cytapheresis Requires high blood flows, central venous access Requires heparin anticoagulation, limiting use in bleeding disorders
Centrifugal apheresis	<ul style="list-style-type: none"> Capable of performing cytapheresis No heparin requirement More efficient removal of all plasma components 	<ul style="list-style-type: none"> Large and heavy equipment Requires citrate anticoagulation Loss of platelets

In the **intermittent-flow** separation devices, multiple aliquots of blood are sequentially withdrawn and routed to a bowl, where each aliquot is processed and then reinfused. In the **continuous-flow method**, blood is withdrawn, centrifuged, and separated, and the desired component removed or returned to the patient in a continuous mode using a hoop-shaped annulus that has strategically placed sampling ports (Fig. 18.1) for the collection of plasma, RBCs, WBCs, and platelets. The intermittent-flow method requires a single-needle vascular access, while the continuous-flow system requires two venous accesses (one for withdrawal and a second one for return) or a dual-lumen dialysis-type venous catheter.

Intermittent-flow blood cell separators (Haemonetics Corporation, Braintree, MA) are rarely used today for therapeutic apheresis. The continuous-flow devices are preferred for therapeutic procedures because of their smaller extracorporeal blood volume, significantly shorter procedure time, and lesser anticoagulant requirement. The most widely used centrifugal blood cell separators for therapeutic apheresis are made by Terumo BCT (Lakewood, CO) and Fresenius Kabi (Bad Homburg, Germany).

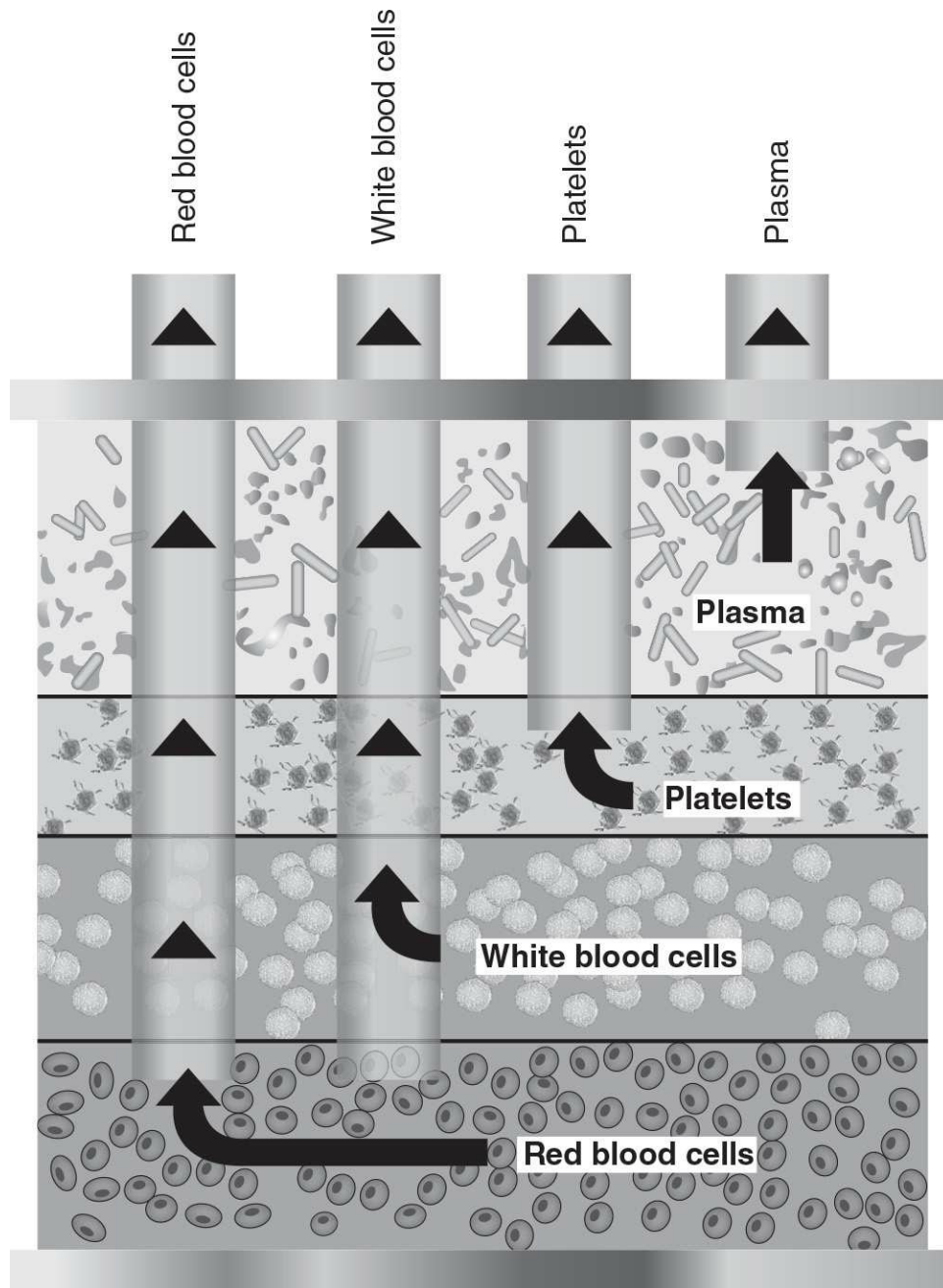

FIGURE 18.1 During centrifugal apheresis, plasma and cells are separated in layers depending on specific gravity. Each layer can be removed, depending on the procedure and fluid and/or cell replacement infused simultaneously. (Courtesy of Dobri Kiproff, MD. Reprinted from Linz W, et al. *Principles of Apheresis Technology*. 5th ed. American Society for Apheresis; 2014. www.apheresis.org.)

B. **Membrane plasma separation (MPS).** Membrane plasma separators are derived from the technology used in dialysis. Hollow-fiber filters for MPS look very similar to dialysis

filters. It is easy to assume that one can simply exchange the dialysis filter with an MPS filter and perform a hemofiltration procedure without dialysate. However, removing plasma is physiologically different from removing ultrafiltrate. When water is removed from the intravascular compartment, extravascular fluid can diffuse in to buffer the volume removal. When plasma is removed from the intravascular compartment, refilling rate of the vascular compartment is reduced. Therefore, there is a higher risk of cardiovascular complications during plasma exchange. Equipment specifically designed for membrane plasma separation must be used to assure patient safety. Membranes with a molecular-weight cutoff of about 3 million daltons are used, which is sufficient to allow passage of immune complexes (MW \approx 1 million). MPS filters can be manufactured in either a hollow-fiber or a parallel-plate configuration. An example of a hollow-fiber plasma separator is the Plasma-Flo made by Asahi (Apheresis Technologies, Palm Harbor, FL). The membrane allows plasma only to pass, as the pores are small enough to hold back the formed elements of the blood. The membrane has a sieving coefficient (ratio of concentration in filtrate to blood) between 0.8 and 0.9 for albumin, IgG, IgA, IgM, C3, C4, fibrinogen, cholesterol, and triglycerides (at a blood flow rate of 100 mL/min and a transmembrane pressure [TMP] of 40 mm Hg) (Fig. 18.2). A number of manufacturers offer either modified CRRT equipment or dedicated instruments for membrane plasmapheresis.

Membrane plasma separation (MPS) must be performed at low TMP (<500 mm Hg) to avoid hemolysis. With hollow-fiber devices, the blood flow rate should exceed 50 mL/min to avoid clotting. The ideal blood flow rate (Q_b) is usually 100–150 mL/min. When the blood flow rate is 100 mL/min, a plasma removal rate of 30–50 mL/min can be expected. Thus, the average time required to perform a typical membrane filtration ($V_e = 2,800$ mL) is <2 hours (40 mL/min \times 60 minutes = 2,400 mL/hr).

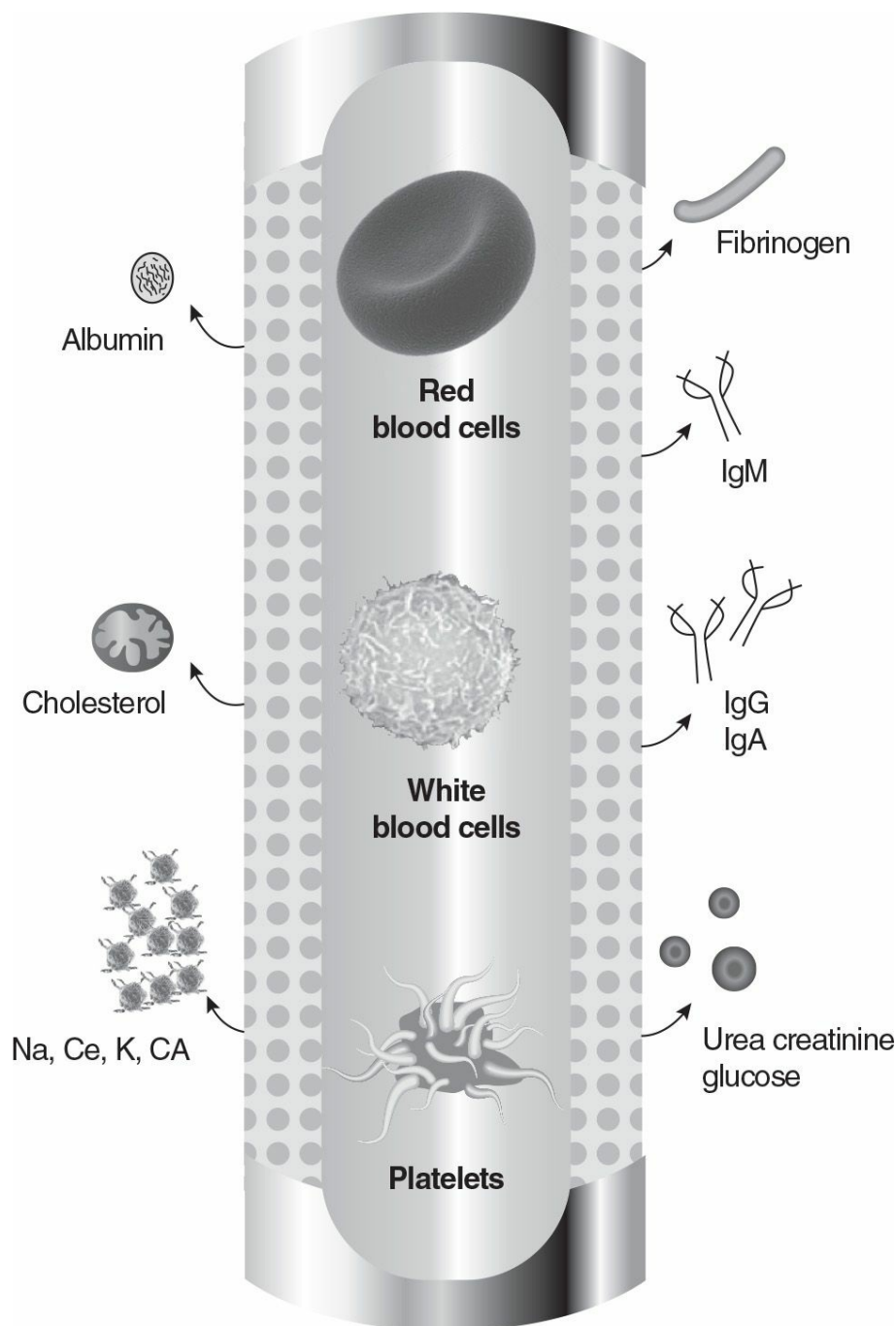

FIGURE 18.2 During membrane plasma separation, blood cells are not allowed to pass through the pores of the filter, while plasma constituents pass through. (Courtesy of Dobri Kiproff, MD. Reprinted from Linz W, et al. *Principles of Apheresis Technology*. 5th ed. American Society for Apheresis; 2014. www.apheresis.org.)

C. **Comparison of membrane and centrifugation devices (Table 18.4).** Centrifugal blood cell separators are the preferred therapeutic apheresis devices in the United States. These are capable of performing cytapheresis (leukapheresis, erythrocytapheresis, and thrombocytapheresis) in addition to plasmapheresis. Centrifugal devices also operate at lower whole-blood and plasma flow rates (Q_b in the range of 40–50 mL/min). Such blood flows can be obtained from a large peripheral vein (antecubital vein), eliminating the risks associated with central vascular access in many cases.

MPS is faster for performing plasmapheresis. However, it is unsuitable for treating patients with the hyperviscosity syndrome due to paraproteinemia (most commonly

Waldenström macroglobulinemia) or patients with cryoglobulinemia, because the available devices are not efficient in removing very large macromolecules. MPS normally is performed using heparin as an anticoagulant; when treating bleeding disorders such as TTP, heparin should not be used, and a citrate-based method is indicated instead.

IV. **VASCULAR ACCESS.** As noted earlier, for the centrifugal device systems, a Q_b in the range of 40–50 mL/min is required. This can sometimes be obtained from a large peripheral vein (antecubital vein). On the contrary, a central venous access is needed when using MPS because a blood flow rate between 100 and 150 mL/min is required for the successful and efficient operation of the filtration system. For MPS the best approach is the use of a large-bore, dual-lumen catheter, similar to the ones used for dialysis and especially dedicated for apheresis. The majority of intravascular devices available for nondialysis use, such as Swan–Ganz catheters and triple-lumen catheters, almost never provide adequate blood flow for plasmapheresis, although they may be suitable for blood return.

Citrate infusion (see later) causes an acute reduction in the plasma ionized calcium level (in the face of normal total serum calcium level), which can have a local effect on the cardiac conduction system and can generate life-threatening arrhythmia, particularly when blood is returned centrally close to the atrioventricular node of the heart. Cardiac rhythm should be monitored, and blood-warming devices should be used, especially if processed blood is returned centrally.

When the nature of the disease requires chronic TPE (e.g., hypercholesterolemia, cryoglobulinemia), the creation of a permanent access is preferred. Patients may undergo placement of a central catheter for long-term use, or long-term access may be achieved using an arteriovenous fistula or polytetrafluoroethylene graft.

V. **ANTICOAGULATION.** Anticoagulation is mandatory for therapeutic apheresis procedures, whether by MPS or centrifugal devices. In general, filtration devices use heparin, whereas centrifugal machines require the use of citrate.

A. **Heparin.** Heparin sensitivity and half-life vary greatly in patients, and individual adjustment of dosage is necessary. Heparin doses may need to be increased in patients with low Hct (increased volume of distribution) and when the plasma filtration rate is high (a high plasma filtration rate results in increased net removal of heparin, which has a sieving coefficient of 1.0).

B. **Citrate.** Anticoagulant citrate dextrose (ACD) is used as the anticoagulation solution for most TPE procedures. Citrate chelates calcium, which is a necessary cofactor in the coagulation cascade, and this inhibits thrombus formation and platelet aggregation. ACD comes in two standard formulations. Formula A (ACD-A) contains 2.2 g/dL of sodium citrate and 0.73 g/dL of citric acid. Formula B (ACD-B) contains 1.32 g/dL of sodium citrate and 0.44 g/dL of citric acid. ACD-A is used for all continuous-flow centrifugal devices.

Although bleeding is uncommon with citrate, low plasma ionized calcium levels commonly occur. Therefore, patients must be carefully observed for symptoms and signs of hypocalcemia (perioral and/or acral paresthesias; some patients may experience shivering,

light-headedness, twitching, tremors, and, rarely, continuous muscular contractions that result in involuntary carpopedal spasm). If plasma ionized calcium levels fall more severely, symptoms can progress to frank tetany with spasm in other muscle groups, including life-threatening laryngospasm. Grand mal seizures have been reported. These symptoms and signs may be accentuated by alkalosis due to hyperventilation. Reductions of ionized calcium values also lengthen the plateau phase of myocardial depolarization, manifested electrocardiographically by prolongation of the QT interval. Very high citrate levels, with corresponding low ionized calcium, lead to depressed myocardial contractility, which, though very rare, can provoke fatal arrhythmias in patients undergoing apheresis.

1. **Prevention of low ionized calcium levels during citrate anticoagulation.** The following measures can be considered.
 - a. **Limiting the rate of citrate delivery to the patient.** The rate of citrate infusion must not exceed the capacity of the body to metabolize citrate rapidly. The ability to metabolize citrate varies from patient to patient. Because the amount of citrate infused is proportional to the blood flow rate, high blood flow rates should not be used. Most of the centrifugal devices estimate the patient's blood volume by a nomogram and then automatically set the blood flow rate to limit the rate at which citrate is being infused.

Patients with liver and renal insufficiency may have an impaired ability to metabolize citrate, and in these patients, citrate infusion should be performed with great caution. FFP (fresh frozen plasma) contains up to 14% citrate by volume. In cases where FFP, instead of albumin, is being used as the replacement fluid, the total citrate reinfusion rate to the patient should include the citrate in the FFP.
 - b. **Providing additional calcium to the patient during the plasmapheresis procedure.** Calcium can be given either orally or intravenously. One can, for example, give orally 500-mg (5-mmol) tablets of calcium carbonate every 30 minutes. Another approach is to infuse calcium gluconate 10% continuously intravenously, in a proportion of 10 mL of the calcium gluconate solution per liter of replacement fluid (Weinstein, 1996). In addition to these measures, intravenous boluses of calcium can be given whenever symptoms of hypocalcemia become manifest.
2. **Alkalosis during citrate infusion.** There is the danger of developing metabolic alkalosis (although this is a very rare occurrence) because citrate in the form of sodium citrate is metabolized to bicarbonate. In patients with liver disease, who may have impaired ability for citrate metabolism, acid–base status during plasmapheresis using citrate anticoagulation should be monitored with special care.

VI. REPLACEMENT SOLUTION. The selection of the type and amount of replacement fluids is an important consideration in the prescription of plasmapheresis. The diversity of disease and patient conditions makes the elaboration of uniform suggestions for replacement fluid difficult. Nevertheless, certain guidelines are useful, and they can be modified by the specific conditions encountered.

In most plasmapheresis procedures, replacement by colloidal agents is essential to

maintain hemodynamic stability. In practice, this is limited to albumin, generally in the form of an isotonic 5% solution, or to plasma in the form of FFP. The advantages and disadvantages of each are listed in Table 18.5.

A. **Fresh frozen plasma.** FFP has the advantage of being similar in composition to the filtrate being removed from the patient, but is associated with side effects such as allergic reactions. Urticaria and hives, which may be severe, are frequently present with the use of FFP. Rarely, anaphylactic reactions result in a form of noncardiogenic pulmonary edema caused by passive transfusion of leukoagglutinins. Another cause of anaphylaxis is infusion of IgA-containing FFP to a patient with selective IgA deficiency. Because FFP may contain appreciable amounts of anti-A and anti-B isoagglutinins, ABO compatibility between donor and recipient is necessary. As noted earlier, FFP contains citrate, and use of FFP increases the risk of citrate-mediated low ionized calcium reactions. Also, there is a small but measurable incidence of transmission via FFP of hepatitis B (0.0005% per unit), hepatitis C (0.03% per unit), and HIV (0.0004% per unit). Although these infectious risks are now much smaller with predonation and postdonation testing, it should be kept in mind that with each plasmapheresis treatment where 3 L of plasma is replaced with FFP, the 3 L of replacement FFP is made up of 10–15 units of plasma coming from an equal number of donors. Detergent-treated plasma is available from a number of manufacturers.

TABLE

18.5

Choice of Replacement Solution

Solution	Advantages	Disadvantages
Albumin	No risk of hepatitis Stored at room temperature Allergic reactions are rare No concern about ABO blood group blood group Depletes inflammation mediators	Expensive No coagulation factors No immunoglobulins
Fresh frozen plasma	Coagulation factors Immunoglobulins “Beneficial” factors	Risk of hepatitis, HIV transmission Allergic reactions Must be thawed Must be ABO-compatible Citrate load

HIV, human immunodeficiency virus.

Use of FFP as the replacement fluid makes measurement of the efficacy of plasmapheresis more difficult in certain patients (e.g., one cannot simply follow serum levels of IgG and other immunoglobulins). Also, FFP may replenish some factors removed during plasmapheresis that could participate in the inflammatory process.

At present, the specific indications for replacing some or all of the removed plasma with FFP during plasma exchange are (a) thrombotic thrombocytopenic purpura–hemolytic uremic syndrome (TTP/HUS), (b) preexisting defect in hemostasis and/or low pretreatment serum fibrinogen level (<125 mg/dL), and (c) patients at risk for bleeding; for example,

patients who are pre- or postsurgery. With regard to TTP/HUS, there is a rationale for using FFP as the sole replacement fluid because infusion of FFP by itself may be therapeutic and because in the presence of thrombocytopenia the risk of bleeding as a consequence of minor perturbations in the coagulation factors may be higher.

In general, because plasmapheresis also depletes coagulation factors, replacement by albumin and crystalloid alone may result in depletion of these factors and place the patient at increased risk of bleeding. This is not likely to occur after one or two plasma exchanges, particularly if they are performed more than a day apart, because the half-life for most clotting factors is approximately 24–36 hours.

- B. **Albumin.** Because of the above concerns with the use of FFP, we recommend albumin as the initial replacement solution. Five percent albumin solution at a concentration of 5 g/dL (50 g/L) in saline with 130–160 mmol of sodium chloride per liter can be replaced in a volume equal to that of the removed plasma. With modern equipment, this can be done simultaneously and at the same rate as plasma removal. However, because a substantial proportion of the albumin that is infused early during the procedure is exchanged during the course of a plasmapheresis procedure, a more economical approach (when exchange volume is equal to one plasma volume and in the absence of hypoalbuminemia) is to replace the initial 20%–30% of the removed plasma volume with crystalloid, such as 0.9% saline and then substitute the balance with the above-mentioned 5% albumin solution. This method would result in a final concentration of albumin in the vascular space of approximately 3.5 g/dL (35 g/L), sufficient to maintain oncotic pressure and avoid hypotension. The approach should not be used in patients with hyperviscosity, patients with neurologic diseases, and patients with other causes of hypotension.

Purified human serum albumin (HSA) solutions do not transmit viral diseases because of prolonged heat treatment during processing and have become a favored replacement fluid in TPE. They have an excellent overall safety record. The incidence of adverse reactions of any kind has been estimated to be 1 in 6,600 infusions. Severe, potentially life-threatening reactions occur in approximately 1 of every 30,000 infusions. When preparing 5% albumin solution from more concentrated solutions, 0.9% saline must be used as the diluent; use of water as a diluent has resulted in severe hyponatremia and hemolysis (Steinmuller, 1998).

The amount of fluid replacement given depends on the patient's volume status. The replacement volume can be adjusted, either manually or automatically, from 100% of the removed volume to less than 85%. Use of lower replacement volumes is generally not recommended, since this may contract the intravascular volume and result in hemodynamic instability.

VII. COMPLICATIONS. The side effects observed in plasma exchange are generally not severe and can be managed easily if they are anticipated. The main side effects are listed in Table 18.5.

Complications range from 4% to 25%, with an average of 10%. Minimal reactions occur in about 5% of treatments and are characterized by urticaria, paresthesias, nausea, dizziness, and leg cramps. Moderate reactions (5%–10% of treatments) include hypotension, chest pain, and ventricular ectopy. All are usually brief and without sequelae. Severe events occur in <3% of treatments and are mainly related to anaphylactoid reactions associated with FFP

administration. The estimated mortality rate associated with plasmapheresis is 3–6 per 10,000 procedures. The majority of deaths include anaphylaxis associated with FFP replacement, pulmonary embolism, and vascular perforation. The most important complications are summarized in Table 18.6. Strategies for avoidance and management of these complications are summarized in Table 18.7.

- A. **Citrate.** The most common complication of therapeutic apheresis when using centrifugal machines is related to citrate toxicity as described in the anticoagulation section.
- B. **Hemodynamic complications.** Hypotension (2% overall incidence) is due mainly to intravascular volume depletion, which may be exaggerated by the large (250–375 mL) volume of blood externalized in the extracorporeal circuit. Other causes include vasovagal episodes, use of hypo-oncotic fluid replacement, delayed or inadequate volume replacement, anaphylaxis, cardiac arrhythmia, and cardiovascular collapse.

TABLE
18.6

Complications of Plasmapheresis

Related to Vascular Access

- Hematoma
- Pneumothorax
- Retroperitoneal bleed
- Local or systemic infection

Related to the Procedure

- Hypotension from externalization of blood in the extracorporeal circuit
- Hypotension due to decreased intravascular oncotic pressure
- Bleeding from reduction in plasma levels of coagulation factors
- Edema formation due to decreased intravascular oncotic pressure
- Loss of cellular elements (platelets)
- Hypersensitivity reactions (ethylene oxide)

Related to Anticoagulation

- Bleeding, especially with heparin
- Hypocalcemic symptoms (with citrate)
- Arrhythmias
- Hypotension
- Numbness and tingling of extremities
- Metabolic alkalosis from citrate

Related to Replacement Fluids

- Hypotension (use of hypo-oncotic saline)
- Anaphylaxis (FFP)

TABLE

Strategies to Avoid Complications during Plasmapheresis

Complication	Management
Low ionized calcium	Prophylactic infusion of 10% calcium gluconate during treatment
Hemorrhage	2–4 units of fresh frozen plasma at the end of the procedure
Thrombocytopenia	Consider membrane plasma separation
Volume-related hypotension	Adjust volume balance
Infection postapheresis	Infusion of intravenous immunoglobulin (100–400 mg/kg)
Hypokalemia	Ensure a potassium concentration of 4 mM in the replacement solution
Membrane biocompatibility	Change membrane or consider centrifugal method of plasma separation
Hypothermia	Warm replacement fluids
ACE inhibitors	Discontinue ACE inhibitor therapy 24–48 hr before treatments
Sensitivity to FFP or albumin	Consider measuring anti-IgA titers Premedication regimen for sensitized individuals: (a) hydrocortisone I.V. or prednisone; (b) diphenhydramine I.V. or orally; and (c) H ₂ antagonists (cimetidine) I.V.

ACE, angiotensin-converting enzyme; Ig, immunoglobulin.

- C. **Hematologic complications.** Hemorrhagic episodes are rare. Bleeding after insertion of a femoral catheter, bleeding from a previous catheter site, hematemesis, and epistaxis have been described.

After a single plasma exchange, the serum fibrinogen level typically falls by 80%, and prothrombin and many other clotting factor levels also fall by about 50%–70%. The partial thromboplastin time usually increases by 100%. Recovery of plasma levels of coagulation factors is biphasic, characterized by a rapid initial increase up to 4 hours postapheresis and followed by a slower increase 4–24 hours postexchange. Twenty-four hours after treatment, fibrinogen levels are approximately 50%, and antithrombin III levels are 85%, of initial levels; both require 48–72 hours for complete recovery. One day following treatment, the prothrombin level is 75% and factor X is 30% of the original level; by this time, all other coagulation factors will have completely recovered to normal values. When multiple treatments are performed over a short period, the depletion in clotting factors is more pronounced and may require several days for spontaneous recovery. As stated before, when multiple closely spaced treatments are given, it is advisable to replace 2 units of FFP at the end of each treatment. Device-specific thrombocytopenia has been reported as a result of TPE, and this has caused confusion in assessing response during treatment of disorders such as TTP (Perdue, 2001).

- D. **Angiotensin-converting enzyme (ACE) inhibitors.** Anaphylactic or atypical anaphylactoid reactions have been reported in patients taking ACE inhibitors during hemodialysis, low-density lipoprotein (LDL) affinity apheresis, and other apheresis-specific columns. These reactions have been related to negatively charged membranes or filters. Experimental evidence has shown that this reaction is not related to the extracorporeal circulation alone.

It is speculated that the fragments of prekallikrein-activating factor present in human albumin lead to endogenous bradykinin release. The severity of the reactions depends on different variables, including drug type and lot of albumin (which may contain different concentrations of the prekallikrein-activating factor). Ideally, therefore, short-acting ACE inhibitors should be held for 24 hours, and long-acting ACE for 48 hours, prior to plasma exchange with membrane devices.

E. **Infection.** The true incidence of infection in TPE is controversial. Studies have not clearly shown a significantly higher occurrence of opportunistic infections among patients treated with immunosuppression and TPE compared to those treated with immunosuppressive therapy alone. However, if a severe infection develops in the immediate post-plasma exchange period, a reasonable approach would be a single infusion of immunoglobulins (100–400 mg/kg intravenously).

F. **Electrolyte, vitamin, and drug removal**

1. **Hypokalemia.** When the replacement solution is albumin in saline, there could be a 25% reduction in serum potassium levels in the immediate postapheresis period. The risk of hypokalemia can be reduced by adding 4 mmol of potassium to each liter of replacement solution.

2. **Metabolic alkalosis.** This may result from infusion of large amounts of sodium citrate.

3. **Drugs.** In general, drugs that are significantly cleared by plasma exchange are the ones that have small volumes of distribution and extensive protein binding. Evidence shows that supplemental dosing of prednisone, digoxin, cyclosporine, ceftriaxone, ceftazidime, valproic acid, and phenobarbital is not necessary after plasma exchange. In contrast, the dosages of salicylates, azathioprine, and tobramycin should be supplemented. The many reports of phenytoin clearance are conflicting; thus, it is necessary to carefully monitor unbound drug levels. We generally recommend that all scheduled medications be given immediately after the procedure.

VIII. **INDICATIONS FOR PLASMAPHERESIS.** The most comprehensive guidelines for the use of therapeutic apheresis are published by the American Society of Apheresis (ASFA). The ASFA evidence-based approach assigns categories to diseases after systematic review of the literature. Furthermore, the quality of the supporting evidence is graded. Category I includes disorders for which apheresis is accepted as first line of therapy. Category II includes diseases for which apheresis is accepted as a second-line therapy (usually after failure of the first line of therapy). Category III includes entities for which the optimal role of apheresis is not established. In these cases, decision making should be individualized. Category IV includes disorders in which published evidence demonstrates apheresis to be ineffective or harmful. Table 18.8 lists disorders for which apheresis is considered first line of therapy, either alone or with other treatment modalities. In these cases, apheresis should be initiated as soon as possible for achieving optimal outcomes. Below is a summary of the use of plasmapheresis in renal disorders.

Goodpasture syndrome (anti-GBM disease)

TTP/HUS

Severe Cryoglobulinemia

Pulmonary renal syndrome with diffuse alveolar damage (DAM)

Antibody-mediated renal graft rejection

Hyperviscosity syndrome

Sickle cell disease crisis (RBC exchange)

Acute demyelinating polyneuropathy (Guillain–Barré Syndrome)

Hyperleukocytosis (leukemia) (leukocytapheresis)

Myasthenia gravis crisis

Thrombocytosis (thrombocytapheresis)

- A. **Anti-GBM disease.** There is convincing evidence of the pathogenicity of anti-GBM antibodies in this disease, which historically was rapidly fatal in untreated patients. Early use of plasmapheresis is strongly indicated, since the response rate is highest when the serum creatinine is relatively low (<500 $\mu\text{mol/L}$ or 5.7 mg/dL). In the largest long-term study using plasmapheresis together with immunosuppressive drugs, almost all patients with creatinine <500 $\mu\text{mol/L}$ (5.7 mg/dL) recovered kidney function, compared with only 8% of those who were already on dialysis. In oliguric dialysis-dependent patients, particularly with a high percentage of crescents on renal biopsy, plasmapheresis should probably be reserved for those with pulmonary hemorrhage, because renal function is unlikely to recover.

The frequency of plasmapheresis should be high enough to rapidly decrease circulating anti-GBM antibody levels. In the large series described earlier, patients received exchange of 50 mL/kg (approximately 1.5 plasma volumes) for 14 consecutive days, or until anti-GBM antibody levels became undetectable. Other authors would advise exchange of two plasma volumes daily for 7 days, followed by alternate day plasmapheresis for another week. Although renal biopsy is preferred to confirm the diagnosis, if the clinical suspicion is high and a reliable assay for anti-GBM antibodies is positive, then treatment should be started immediately. If still indicated clinically, renal biopsy could be performed after the first two or three exchanges, deferring plasmapheresis for 24 hours after biopsy. Citrate anticoagulation may be preferred, where available, in the presence of lung hemorrhage or after renal biopsy. Plasmapheresis may need to be continued beyond the second week, depending on clinical features and anti-GBM antibody levels.

In general, plasma is replaced with 5% albumin, but using FFP for the last liter of the exchange in patients with lung hemorrhage or recent biopsy. If the patient is severely fluid overloaded, the amount of albumin solution can be reduced to 85% (but not less) of the removed plasma volume.

- B. **TTP and HUS.** Both TTP and HUS lead to thrombotic microangiopathy which, in HUS, particularly affects the kidney and, in TTP, often affects the central nervous system. HUS is divided into cases preceded by diarrhea (D+) and those that occur sporadically (D-). D-

HUS may be associated with genetic defects of complement regulators or autoantibodies to these proteins (atypical HUS [aHUS]). In TTP, there may be genetic deficiency of the von Willebrand factor–cleaving protease (ADAMTS13) or autoantibodies against it. Plasmapheresis will replace normal plasma components, regardless of etiology, and will remove autoantibodies when present.

In severe TTP, plasmapheresis should be started as soon as possible. Daily plasmapheresis of at least 1 plasma volume should be performed daily, usually for 7–10 days. Some would advocate using 1.5 plasma volumes for the first three treatments to achieve a rapid effect. Treatment is continued until platelet count is normalized and hemolysis has largely ceased (lactate dehydrogenase below 400 IU/L). Since relapse may recur promptly on stopping treatment, vascular access should be maintained until platelet count is stable. In patients in whom platelet count decreases to $<100,000/\text{mm}^3$, plasmapheresis may be recommenced on an alternate day schedule until platelet count stabilizes. There are now two controlled trials that show the benefit of plasmapheresis with FFP compared with FFP infusions, and a recent meta-analysis of controlled trials shows that plasmapheresis with FFP is the most effective approach in TTP.

Diarrhea-positive (D+) HUS in children is frequently a self-limiting disease, which improves with supportive treatment. There are no randomized trials of plasmapheresis, but there are recent reports of the benefit of plasmapheresis in adults with severe acute D+ HUS. In diarrhea-negative (D–) HUS (atypical HUS), there are no controlled trials, but there are several anecdotal reports of the benefit of plasma exchange for FFP in severely affected patients.

Despite the lack of evidence, a trial of plasmapheresis would be a reasonable approach in severe TTP in pregnancy. Plasmapheresis may also be useful for other secondary causes of TTP, although plasma perfusion over staphylococcal protein A (SPA) columns has been reported to be more effective in mitomycin-induced TTP.

In general, removed plasma is replaced by the same volume of FFP, since the FFP will provide the deficient plasma components. In repeated large volume exchange for TTP, care needs to be taken to avoid hypocalcemia.

Eculizumab (a monoclonal antibody against C5 that inhibits the formation of the membrane attack complex of complement) is being used to treat (D–) HUS, and results have been very encouraging. Recently, (D+) HUS arising from the epidemic that took place in Europe several years ago seemed to respond well to both eculizumab (Delmas, 2014) and plasmapheresis.

- C. **Cryoglobulinemia.** Plasmapheresis has been used for the treatment of cryoglobulinemia for over 20 years because of effective removal of the large immune complexes responsible for clinical features. Although there are no controlled trials, there are multiple reports demonstrating the efficacy of plasma exchange in patients with acute vasculitis and renal involvement. Plasmapheresis can also be considered for hyperviscosity syndrome or where a patient is about to undergo surgery requiring hypothermia. In severe cases, immunosuppressive drugs are also used, together with antiviral therapy in those with hepatitis C.

In general, exchange of 1 plasma volume for 7 days is suggested, while others use

plasmapheresis on alternate days for 2–3 weeks. Replacement fluid should be 5% albumin, which must be warmed to avoid precipitation of circulating cryoglobulins. In occasional patients, long-term treatment once a week is required to control symptoms. Use of a centrifugation device is often preferred because of the possibility of the cryoglobulins blocking the plasma filter as they cool and precipitate. Alternative techniques such as double cascade filtration and cryofiltration are expensive and technically difficult, and are not widely used.

- D. **Antineutrophil cytoplasmic antibody (ANCA)–associated vasculitis.** These patients have a small vessel vasculitis often affecting the kidney, with pauci-immune rapidly progressive glomerulonephritis. This group of diseases includes granulomatosis with polyangiitis (previously Wegener granulomatosis), microscopic polyangiitis, and eosinophilic granulomatosis with polyangiitis (previously Churg–Strauss syndrome). There is mounting evidence for the pathogenic role of ANCA in these conditions. Although early trials did not produce clear-cut results, Pusey (1991) demonstrated the benefit of plasma exchange, together with immunosuppressive drugs in patients already requiring dialysis. A large European multicenter study (MEPEX) confirmed this finding and demonstrated, in patients with a creatinine of >500 $\mu\text{mol/L}$ (5.7 mg/dL), better recovery of renal function in those treated with plasmapheresis compared to patients treated with pulse methyl prednisolone. Another recent smaller study reported the benefit of plasmapheresis in patients with a creatinine >250 $\mu\text{mol/L}$ (2.8 mg/dL). A recent meta-analysis confirmed the benefit of adjunctive plasmapheresis compared with standard therapy in preventing development of end-stage renal disease. A large international controlled trial of plasmapheresis in ANCA-associated vasculitis in patients with $\text{GFR} < 50$ mL/min (PEXIVAS) is in progress.

On the basis of the MEPEX study, we would recommend daily exchange of 1.5 plasma volumes for 7 days. FFP should be used for the last liter of exchange for those with pulmonary hemorrhage or a recent renal biopsy. Some patients may require longer periods of treatment, depending on their clinical response.

- E. **Multiple myeloma.** Multiple myeloma can lead to renal impairment through a wide variety of mechanisms, the commonest of which is light-chain cast nephropathy. Although plasmapheresis effectively removes the paraprotein responsible, early trials produced conflicting results. A more recent, larger study failed to show significant benefit of plasmapheresis in addition to standard chemotherapy. However, few of those patients had cast nephropathy confirmed by renal biopsy. A retrospective study from the Mayo Clinic suggested the benefit of plasmapheresis in patients with proven cast nephropathy who had high light-chain levels and severe renal impairment.

In general, we would suggest a regimen of five consecutive exchanges for 5% albumin in patients presenting with acute kidney injury due to light-chain nephropathy. Depending on the clinical response and paraprotein levels, longer treatment may be needed in some patients.

An alternative approach to plasmapheresis that has gained favor in the past 5 years is based on effective removal of light chains by hemodialysis using a special high-cutoff dialyzer. In addition to standard chemotherapy, with or without bortezomib, very intensive dialysis is done. In the initial study, in patients with acute renal failure secondary to

multiple myeloma, two high-cutoff filters (Theralite, Gambro Renal Products) were connected in series, and 8-hour dialysis sessions were given daily for the first 5 days, followed by 8-hour sessions on alternate days for the next 12 days, followed by 6-hour treatments three times per week. Four grams of salt-poor albumin were given at the end of each extended dialysis session, and intravenous magnesium and oral calcium were given if predialysis levels were low (Hutchison, 2009). The level of free light chains was monitored using an immunoassay. Response was encouraging, in terms of sizeable reduction in serum-free light chains and a high percentage of patients recovering renal function. Two multicenter controlled trials (EULITE and MYRE) are ongoing in Europe to investigate this approach.

- F. **Systemic lupus erythematosus.** Plasmapheresis has been widely used in lupus nephritis to remove circulating autoantibodies and immune complexes. Despite positive anecdotal reports, one randomized controlled trial showed no benefit of the addition of plasmapheresis to immunosuppressive drugs in patients with lupus nephritis followed up for 3 years. However, patients with crescentic nephritis and those requiring dialysis were excluded, and it could be argued that short-term intervention such as plasmapheresis would have a better effect in these patients. An international trial using high-dose cyclophosphamide synchronized with plasmapheresis was suspended because of a high incidence of adverse effects, so this approach cannot be recommended. In our experience, and in many anecdotal reports, plasmapheresis should be considered in patients with life-threatening manifestations of systemic lupus erythematosus (SLE), for example, those with crescentic nephritis, pulmonary hemorrhage, cerebral lupus, or catastrophic antiphospholipid syndrome. There are also reports of the use of immunoadsorption using protein A columns in patients with severe disease unresponsive to other treatment.

We would suggest an initial course of seven exchanges of 1–1.5 plasma volumes for 5% albumin in patients with life-threatening disease. FFP should be used for the last liter of the exchange in the presence of lung hemorrhage or recent renal biopsy.

- G. **Recurrent focal segmental glomerulosclerosis (FSGS).** Recurrent FSGS in renal transplants appears to be mediated in some cases by a circulating factor that increases glomerular permeability. The use of plasmapheresis in FSGS in the native kidney has produced variable results, perhaps because some of these patients have a genetic defect in proteins contributing to the glomerular filtration barrier. FSGS can recur promptly following renal transplantation (15%–55% of cases) and, in these patients, plasmapheresis is frequently reported to be of benefit.

In the absence of adequate information, we would suggest the use of exchange of 1 plasma volume for 5% albumin for at least 5 consecutive days, and perhaps for longer, depending on clinical response, in patients with rapid recurrence of proteinuria following renal transplantation.

- H. **Henoch–Schönlein purpura (HSP) and IgA nephropathy.** Patients with HSP and primary IgA nephropathy may develop RPGN due to crescentic glomerulonephritis. The histologic features may be similar to those with ANCA-associated vasculitis. The successful use of plasmapheresis, usually with immunosuppressive drugs, has been reported in several small series of patients. We have observed improvement in renal function in some patients

treated with this approach.

It would be reasonable to perform seven exchanges of 1–1.5 plasma volumes for 5% albumin in patients with active crescentic nephritis and deteriorating renal function, based on the experience in ANCA-associated vasculitis.

- I. **Hyperviscosity syndrome.** This occurs most commonly with Waldenström macroglobulinemia (50% of cases) and occasionally with myeloma and cryoglobulinemia. Hyperviscosity leads to RBC aggregation and reduced blood flow, leading to ischemic dysfunction of several organ systems, including the central nervous system, retina, and kidney. Although there are no controlled trials, there are several reports of the benefit of plasmapheresis in controlling clinical features pending the effects of treatment for the underlying disorder.

In the absence of adequate evidence, we would suggest using daily exchange of one plasma volume for 5% albumin for 3–5 days or until blood viscosity normalizes and the patient is clinically stable.

- J. **Renal transplantation.** Plasmapheresis has been used for over 20 years for treating antibody-mediated rejection and, more recently, as part of the desensitization protocol for ABO-incompatible or highly sensitized patients. Indications for plasmapheresis in renal transplant rejection are not yet clear-cut, but several trials have suggested a benefit in patients with acute antibody-mediated rejection, often with concomitant intravenous immunoglobulin (IVIG) therapy. However, there was no apparent benefit in chronic rejection. Both plasmapheresis and protein A immunoabsorption have been used to remove preformed anti-HLA antibodies in highly sensitized patients, with around 70% graft survival at 1 year. There are also reports that plasmapheresis is effective in allowing renal transplantation in ABO-incompatible patients, often with the use of additional immunosuppression such as rituximab.

We would suggest five exchanges of 1 plasma volume for 5% albumin, together with IVIG, for acute antibody-mediated rejection. The use of plasmapheresis in desensitization protocols for high-risk patients should only be carried out in specialized centers.

- K. **Poisoning and drug overdose.** There are no ASFA class I indications for plasmapheresis in this area. However, there are case reports of plasmapheresis being used in *Amanita phalloides* mushroom poisoning, to help clear digoxin-Fab complexes in patients with renal failure, to treat snakebite or cisplatin overdose, and to remove infused monoclonal antibodies when this is required (Schutt, 2012).

IX. THE SELECTIVE APHERESIS PROCEDURES

- A. **Rationale.** While conventional plasmapheresis can remove target plasma elements such as immunoglobulins, cryoproteins, and lipids, it does so without specificity and requires replacement solutions such as albumin and donor plasma, which can be expensive and lead to adverse reactions. Selective apheresis procedures have been developed to target and remove a specific element from the plasma, and return all other plasma proteins, thus eliminating the need for replacement solutions and the loss of beneficial plasma constituents.
- B. **LDL apheresis.** In the United States, LDL apheresis is currently approved for patients with homozygous familial hypercholesterolemia or in patients with LDL ≥ 300 mg/dL (7.8

mmol/L) or LDL ≥ 200 mg/dL (5.2 mmol/L) plus documented coronary artery disease despite maximal medical therapy. Other healthcare systems have less stringent criteria. In general, these procedures are performed once every one to two weeks, depending on LDL level, though intervals may be lengthened if the patient is tolerating lipid-lowering therapy. LDL apheresis should be considered a chronic lifelong therapy, and therefore, peripheral IVs or arteriovenous fistulas are recommended for access over tunneled dialysis catheters.

There are a variety of techniques available worldwide for the selective removal of LDL-cholesterol; in the United States, only the Liposorber system (Kaneka Corporation, Osaka, Japan) and the Heparin-induced Extracorporeal LDL-Cholesterol Precipitation (H.E.L.P.) system (B. Braun, Bethlehem, PA) are FDA-approved for LDL apheresis. With the Liposorber system, blood is passed through a membrane plasma separator before entering one of two dextran sulfate–based immunoabsorption columns (LA-15 column) on the MA-03 machine. Dextran sulfate is a negatively charged molecule with low toxicity that selectively binds the positively charged Apo-B–containing lipoproteins (LDL, VLDL, and Lp[a]) with high affinity, thus removing them from the circulating plasma. Heparin is used for anticoagulation. A 1.5 plasma volume is targeted for processing, to achieve an LDL reduction of 73%–83% after a single treatment. The negatively charged surface of the adsorbers promotes bradykinin release, thus ACE inhibitors are contraindicated in patients on this modality, but angiotensin receptor blockers may be used instead. In the H.E.L.P. system, whole blood is passed through a plasma separator, and lipoproteins as well as fibrinogen are selectively precipitated with heparin buffered at a pH of 5.12. The precipitate is then removed from the plasma by a polycarbonate membrane, and the heparin removed by a heparin adsorber, and, finally, the plasma is restored to a physiologic pH via bicarbonate dialysis. LDL reduction with this procedure ranges from 45% to 67% after a single treatment. There is greater removal of C3, C4, plasminogen, factor VIII, and fibrinogen with the H.E.L.P. system. Removal of fibrinogen has a positive effect on hemorheology and has been utilized in the treatment of sudden hearing loss, a disorder characterized by a markedly increased fibrinogen, erythrocyte aggregation, and plasma viscosity (though this is not currently an FDA-approved indication). Both techniques of LDL apheresis available in the United States require heparin for anticoagulation. With the H.E.L.P. system, ACE inhibitors are not contraindicated.

Several other techniques are available worldwide to selectively remove LDL-cholesterol. In Europe, an immunoabsorption column containing anti-apoprotein B100-antibodies (Therasorb-LDL, Miltenyi Biotec, Germany) is available for the treatment of hyperlipidemia. Owing to high costs, these columns are typically regenerated and stored, which can be a cumbersome process. Two whole-blood systems are also in use that do not require plasma separation: DALI (Direct Adsorption of Lipoprotein, Fresenius, Germany) and a whole-blood version of the Liposorber system (Liposorber D, Kaneka Pharma Europe N.V.). There is also an immunoabsorptive device (Lipopak, Pocard, Moscow, Russia) that is marketed to target lipoprotein(a), which is an independent risk factor for coronary heart disease.

- C. **Immunoabsorption columns.** There are a variety of columns available worldwide that have been designed to selectively bind a target molecule and remove it from the circulating plasma

(Fig. 18.3). The columns currently available either contain SPA, a specific peptide or synthetic antigen, or an immobilized antibody covalently bound to an inert and insoluble matrix (such as cellulose) in a column of gel beads. SPA has a high affinity for the Fc portions of IgG1, IgG2, and IgG4 and depletes the plasma of IgG autoantibodies or circulating immune complexes that contain IgG. There is an SPA column (Immunosorba, Fresenius Medical Care) available in other countries used for the treatment of antibody-mediated rejection in kidney transplant, dilated cardiomyopathy, SLE, pemphigus vulgaris, and anti-FVIII antibody. Examples of immunoadsorption columns that utilize immobilized antibodies include anti-apoprotein B (Therasorb-LDL) used for hyperlipidemia as mentioned earlier and anti-IgG antibody columns (Therasorb-Ig) used in Europe for the treatment of autoimmune diseases such as SLE, myasthenia gravis, dilated cardiomyopathy, and ABO-incompatible kidney transplantation. Finally, many immunoadsorption columns have been developed that contain either an immobilized antigen or peptide designed to bind a specific circulating antibody or molecule. An example is the Glycosorb ABO column, which contains terminal trisaccharide A or B blood group antigen immobilized on sepharose, which binds circulating anti-A or anti-B antibodies, and which can be used to facilitate ABO-incompatible organ transplantation.

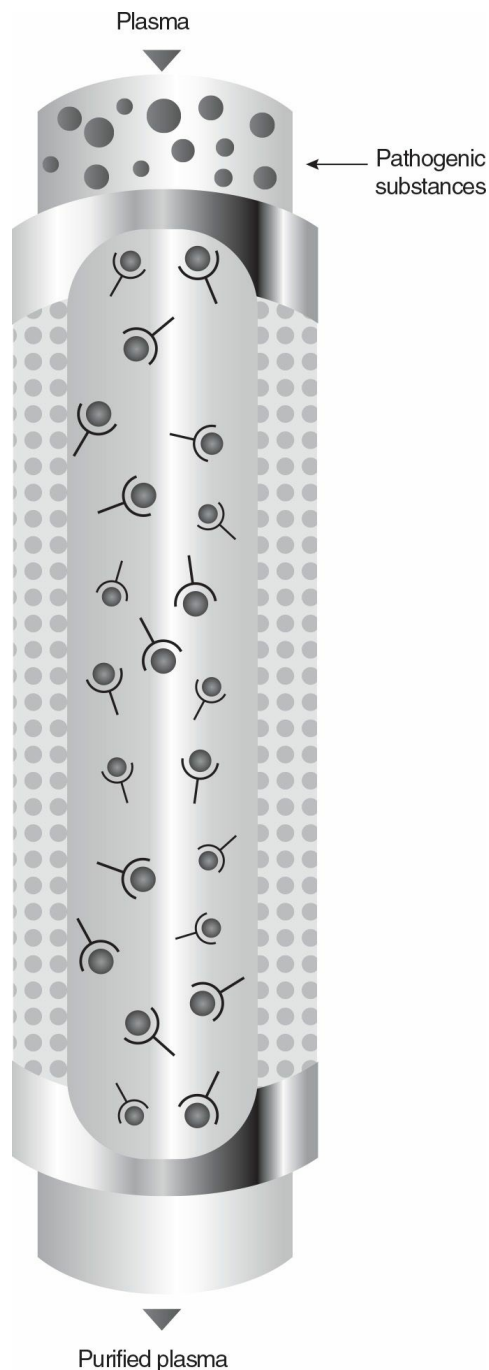

FIGURE 18.3 Immunoabsorbent columns retain pathogens by binding them to elements in the column. (Courtesy of Dobri Kiproff, MD. Reprinted from Linz W, et al. *Principles of Apheresis Technology*. 5th ed. American Society for Apheresis; 2014. <http://www.apheresis.org>.)

- D. **Double filtration plasmapheresis (DFPP).** DFPP or “cascade filtration” refers to the process of using a primary membrane plasma separator to isolate the plasma, followed by a secondary plasma fractionator to remove target solutes based on molecular size and weight. It has been used for the treatment of hypercholesterolemia, cryoglobulinemia, Waldenström macroglobulinemia, and diseases with impaired microcirculation. There are a variety of secondary plasma fractionators available with varying pore size to allow for targeted filtration of the desired molecule. While it is more selective than conventional plasmapheresis, valuable proteins such as IgM can be lost in the filter, and the capacity of the system is limited by filter clotting with retentate.
- E. **Cryofiltration.** Cryoglobulins can be removed by conventional plasmapheresis, DFPP, or by a

technique called cryofiltration. There are two basic methods for cryofiltration. In the first method, plasma is separated either by a centrifugal- or membrane-based system, and the plasma is pumped at 20–30 mL/min through a cooling system at 4°C and then passed through a cryofilter (Versapor, Pall Medical) to collect the precipitated cryoproteins/cryoglobulins. The cryo-depleted plasma is then warmed to 37°C, mixed with the cells, and returned to the patient. The second technique of cryofiltration focuses on cryogel removal. Cryogel is precipitated fibrinogen, extra-domain-A fibronectin, fibrin split products, and fibronectin. This technique uses a heparin infusion (2,000 unit bolus followed by 1,000–2,000 units/hr) to form the core of the cryogel upon which the other proteins aggregate. A plasma fractionator then removes the cryogel from the circulating plasma.

X. OTHER APHERESIS PROCEDURES

A. Extracorporeal photopheresis (ECP). ECP is an online processing modality initially developed for the treatment of cutaneous T-cell lymphoma (Sezary syndrome). It is also used as a treatment for selected patients with cell-mediated alloimmune disorders such as graft-versus-host disease and cellular-type rejection in heart and lung transplantation. During this procedure, centrifugation is used to collect WBCs. The WBC product is then injected with 8-methoxypsoralen (8-MOP) and exposed to a controlled dose of ultraviolet-A (UV-A) light prior to being returned to the patient. UV-A light activates 8-MOP, leading to cross-linking of DNA, thereby inducing apoptosis in T-cells and modifying dendritic cells. This is thought to induce clonal-specific changes in ongoing immune responses, including production of T-regulatory cells which shift the balance toward tolerance. There are two systems developed by Therakos (UVAR XTS and CELLEX). Heparin is used for anticoagulation; access is typically by peripheral IVs or Vortex catheter. Typical treatments are done in pairs on successive days, and repeated every 2 or more weeks; clinical benefit accrues gradually.

XI. STEM CELL TRANSPLANTATION AND OTHER CELL THERAPIES. Hematopoietic Stem Cells (HPSCs) are collected from patients by leukocytapheresis and used for the treatment of hematologic malignancies, regeneration medicine, and a growing number of other entities.

HPSC can be derived either from bone marrow or from peripheral blood. Mobilized blood HPSCs have few contaminating red cells and have more committed HPSCs, lymphocytes, and other mononuclear cells. These enriched cell populations lead to faster engraftment and immune reconstitution. Because of these advantages and lower morbidity and mortality rates, the great majority of patients undergoing stem cell transplantation have been treated with apheresis-derived autologous peripheral blood HPSC.

Cell therapies such as cancer vaccines (Provenge, Dendreon, Seattle, WA) and emerging gene cellular therapies utilize apheresis-derived autologous peripheral blood mononuclear cells.

References and Suggested Readings

- Braun N, et al. Immunoabsorption onto protein A induces remission in severe systemic lupus erythematosus. *Nephrol Dial Transplant*. 2000;15:1367–1372.
- Cataland SR, Wu HM. Diagnosis and management of complement mediated thrombotic microangiopathies. *Blood Rev*. 2014;28:67–74.
- Clark WF, et al. Plasma exchange when myeloma presents as acute renal failure: a randomized, controlled trial. *Ann Intern Med*. 2005;143:777–784.
- Colic E, et al. Management of an acute outbreak of diarrhoea-associated haemolytic uraemic syndrome with early plasma exchange in adults from southern Denmark: an observational study. *Lancet*. 2011;378:1089–1093.
- Delmas Y, et al. Outbreak of *Escherichia coli* O104:H4 haemolytic uraemic syndrome in France: outcome with eculizumab. *Nephrol Dial Transplant*. 2014;29:565–572.
- Hattori M, et al. Plasmapheresis as the sole therapy for rapidly progressive Henoch-Schönlein purpura nephritis in children. *Am J Kidney Dis*. 1999;33:427–433.
- Hutchison CA, et al. Treatment of acute renal failure secondary to multiple myeloma with chemotherapy and extended high cut-off hemodialysis. *Clin J Am Soc Nephrol*. 2009;4:745–754.
- Hutchison C, Sanders PW. Evolving strategies in the diagnosis, treatment, and monitoring of myeloma kidney. *Adv Chronic Kidney Dis*. 2012;19:279–281.
- Kale-Pradhan PB, Woo MH. A review of the effects of plasmapheresis on drug clearance. *Pharmacotherapy*. 1997;17:684–695.
- Kiproff DD, et al. Adverse reactions associated with mobile therapeutic apheresis: analysis of 17,940 procedures. *J Clin Apher*. 2001;16:130–133.
- Kiproff DD, Hofmann J. Plasmapheresis in immunologically mediated polyneuropathies. *Ther Apher Dial*. 2003;7:189–196.
- Klemmer PJ, et al. Plasmapheresis therapy for diffuse alveolar hemorrhage in patients with small-vessel vasculitis. *Am J Kidney Dis*. 2003;42:1149–1154.
- Levy JB, et al. Long-term outcome of anti-glomerular basement membrane antibody disease treated with plasma exchange and immunosuppression. *Ann Intern Med*. 2001;134:1033–1042.
- Linz W, et al. *Principles of Apheresis Technology*. 5th ed. American Society for Apheresis; Vancouver, BC, Canada; 2014. <http://www.apheresis.org>.
- Maggioni S, et al. How to implement immunoabsorption in a polyvalent dialysis unit: a review. *J Ren Care*. 2014;40:164–71.
- Matsuzaki M, et al. Outcome of plasma exchange therapy in thrombotic microangiopathy after renal transplantation. *Am J Transplant*. 2003;3:1289–1294.
- McLeod BC, et al. *Apheresis: Principles and Practice*. 3rd ed. Bethesda, MD: AABB Press; 2010.
- Menne J, et al. EHEC-HUS consortium. Validation of treatment strategies for enterohaemorrhagic *Escherichia coli* O104:H4 induced haemolytic uraemic syndrome: case-control study. *Br Med J*. 2012;345:e4565.
- Montagnino G, et al. Double recurrence of FSGS after two renal transplants with complete regression after plasmapheresis and ACE inhibitors. *Transpl Int*. 2000;13:166–168.
- Perdue JJ, et al. Unintentional platelet removal by plasmapheresis. *J Clin Apher*. 2001;16:55–60.
- Pusey CD, et al. Plasma exchange in focal necrotizing glomerulonephritis without anti-GBM antibodies. *Kidney Int*. 1991;40:757–763.
- Saddler JE, et al. Recent advances in thrombotic thrombocytopenic purpura. *Hematology*. 2004:407–

- Sanchez AP, Cunard R, Ward DM. The selective therapeutic apheresis procedures. *J Clin Apher.* 2013;28:20–29.
- Schutt RC, et al. The role of therapeutic plasma exchange in poisonings and intoxications. *Semin Dial.* 2012;25:201–206.
- Schwartz J, et al. Guidelines on the use of therapeutic apheresis in clinical practice-evidence-based approach from the Writing Committee of the American Society for Apheresis: the sixth special issue. *J Clin Apher.* 2013;28:145–284.
- Siami GA, Siami FS. Current topics on cryofiltration technologies. *Ther Apher.* 2001;5:283–286.
- Stegmayr B, et al. Plasma exchange as rescue therapy in multiple organ failure including acute renal failure. *Crit Care Med.* 2003;31:1730–1736.
- Steinmuller DR, et al. A dangerous error in the dilution of 25 percent albumin [letter]. *N Engl J Med.* 1998;38:1226–1227.
- Strauss RG. Mechanisms of adverse effects during hemapheresis. *J Clin Apher.* 1996;11:160–164.
- United States Centers for Disease Control. Renal insufficiency and failure associated with IGIV therapy. *Morb Mortal Wkly Rep.* 1999;48:518–521.
- Ward DM. Extracorporeal photopheresis: how, when, and why. *J Clin Apher.* 2011;26(5):276–285.
- Weinstein R. Prevention of citrate reactions during therapeutic plasma exchange by constant infusion of calcium gluconate with the return fluid. *J Clin Apher.* 1996;11:204–210.
- Williams ME, Balogun RA. Therapeutic plasma exchange, principles of separation: indications and therapeutic targets for plasma exchange. *Clin J Am Soc Nephrol.* 2014;9:181–189.
- Winters JL. Lipid apheresis, indications, and principles. *J Clin Apher.* 2011;26:269–275.
- Wolf J, et al. Predictors for success of plasmapheresis on the long-term outcome of renal transplant patients with recurrent FSGS [Abstract]. *J Am Soc Nephrol.* 2005;SA-FC026.
- Zucchelli P, et al. Controlled plasma exchange trial in acute renal failure due to multiple myeloma. *Kidney Int.* 1988;33:1175–1180.

On average, conventional dialysis machines process 30 to 50 L/hr or 100 to 200 L per session of dialysis solution made from highly purified water. In contrast, sorbent dialysis requires as little as 6 L of potable tap water to produce and regenerate high-quality dialysate for an entire treatment. With sorbent dialysis, spent dialysate from the dialyzer is not discarded to a drain but is regenerated by passing it through a sorbent cartridge. The layers of compounds in the cartridge take advantage of three basic principles of chemistry: carbon binding, enzyme conversion, and ion exchange, to remove uremic toxins and regenerate high-quality bicarbonate dialysate during a dialysis treatment.

Sorbent devices operate without being connected to a water supply or a drain; therefore, additional benefits are system mobility and the flexibility of treatment delivery in a wide range of environments. Sorbent systems have been used for acute dialysis in critical care units and at the patient bedside, for home hemodialysis, for military operations, for disaster relief, in rehabilitation centers and nursing homes, in remote locations, and to treat patients on vacation in remote locations. Without the need for plumbing installation or electrical modification, the potential treatment environments with sorbent systems are numerous.

Sorbent systems provide an opportunity to drive innovation, portability, flexibility, and miniaturization in the dialysis domain.

- I. **PRINCIPLES OF SORBENT DIALYSIS.** In sorbent dialysis, the spent dialysate is continuously regenerated to form fresh dialysis solution by passing it through a sorbent cartridge. The initial dialysis solution is mixed in a designated jug using dry powders and 6 L or less of potable tap water. Prior to starting dialysis, this initial solution is recirculated through the sorbent cartridge for the purpose of removing contaminants. This initial recirculation slightly alters the starting dialysis solution's electrolyte composition, as described in more detail below. Once dialysis has been initiated and the patient has been connected into the system, the "spent" dialysate is then routed from the dialyzer outlet port through the sorbent cartridge. In the cartridge, metabolic waste products dissolved in the spent dialysate are adsorbed and/or exchanged for sodium, hydrogen, and bicarbonate ions. The sorbent cartridge also removes potassium, calcium, and magnesium. Regeneration of the final dialysate solution is completed when potassium, calcium, and magnesium are added to the dialysis solution exiting the cartridge by an infusion pump.
 - A. **The sorbent cartridge.** The sorbent cartridge (Fig. 19.1) consists of six layers of materials, which are designed to remove contaminants and uremic solutes while at the same time

maintaining an appropriate dialysate composition. Spent dialysate flows through the cartridge from bottom to top. The **first** and **third layers** with which the dialysate comes into contact contain activated carbon. These layers adsorb heavy metals, chloramines, and other contaminants that can be found in the tap water. In addition, the activated carbon adsorbs many of the organic and middle molecule uremic solutes found in spent dialysate, including creatinine and uric acid. The **second layer** is an enzyme-retention layer. The enzyme present is urease, which catalyzes the conversion of urea to ammonium bicarbonate. The **fourth layer** contains zirconium phosphate and is a cation exchange layer. Its primary function is to adsorb the ammonium ion generated by urea hydrolysis that took place in the second layer. In addition, this cation exchange material adsorbs other positively charged species such as magnesium, calcium, and potassium, as well as heavy metal cations that may be found in tap water such as copper and iron. In exchange for the adsorbed cations, the zirconium phosphate releases hydrogen and sodium. The **fifth layer** is an anion exchange layer containing zirconium oxide. This material adsorbs phosphate, fluoride, and other anions, such as oxoanions of heavy metals, and in exchange release chloride and hydroxyl anions. The **sixth layer** contains sodium bicarbonate. It does not bind anything but releases sodium and bicarbonate.

- B. **Removal of contaminants from the prime solution during predialysis recirculation through the sorbent cartridge.** The initial dialysis solution or “prime” is made by combining dry chemicals with 6 L or less of municipal tap water. This tap water must meet EPA drinking water standards. This initial mixture is not suitable as a dialysis solution, as it may contain contaminants. However, a brief predialysis recirculation of the prime through the sorbent cartridge removes almost all contaminants normally present in potable tap water (assuming that it contains no more than the maximum allowable contaminant limits [MACLs] for potable water as indicated by the US EPA) to levels required for dialysis solution as indicated by ANSI/AAMI RD52. There are two exceptions: recirculation of the prime through the sorbent cartridge does not remove sulfate or nitrate to an appreciable extent. However, as long as initial levels of sulfate and nitrate are less than the maximal allowed levels for tap water (10 mg/L for nitrate and 250 mg/L for sulfate), because only 6 L of tap water are used, the total sulfate (or nitrate) load potentially transferable to the patient is small.

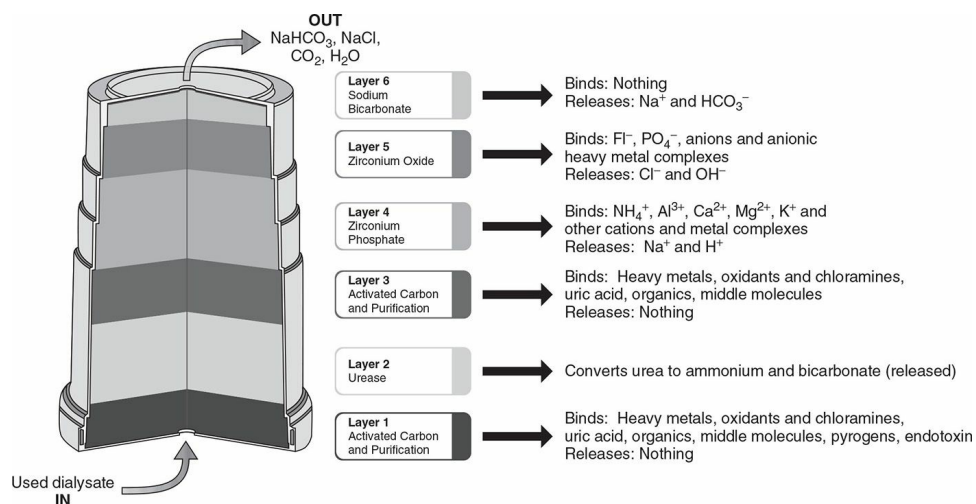

FIGURE 19.1 Structure of a sorbent cartridge.

C. **Changes to the electrolyte composition of the prime solution during predialysis recirculation.** Concentrations of sodium bicarbonate and sodium chloride are user-selectable by choosing different packets of dry chemicals to dissolve. Upon priming the cartridge, a portion of the sodium in the prime will be adsorbed by the zirconium phosphate layer of the cartridge in exchange for hydrogen ions. The release of these hydrogen ions into the priming dialysis solution would result in a lowering of the starting bicarbonate concentration initially present in the prime solution as the protons react with bicarbonate to form carbonic acid (i.e., CO_2 and water). However, release of sodium bicarbonate from the sixth layer of the cartridge serves as a buffer and prevents the bicarbonate concentration of the prime solution from dropping during the predialysis recirculation period. In fact, the initial bicarbonate concentration of the prime at the end of the predialysis recirculation phase often will be slightly higher than the initial bicarbonate level of the prime at the time of mixing. Calcium, magnesium, and potassium are not added to the prime solution, since the cartridge would remove them during the initial recirculation period. Instead, once treatment begins, these elements are infused at appropriate rates into the stream exiting the cartridge; as a result, the final dialysis solution that reenters the dialyzer contains appropriate concentrations of these ions.

1. **Adjusting dialysis solution sodium.** Sodium in the dialysis solution originates from three sources: the sodium-containing electrolytes added to the prime solution, sodium added to the dialysate by the cartridge from cation exchange and from the sodium bicarbonate layer, and diffusion of sodium from patient blood to dialysate in the dialyzer. The zirconium phosphate layer adsorbs the ammonium that was generated from enzymatic conversion of urea, and it also adsorbs magnesium, calcium, and potassium. In exchange for these adsorbed cations, the zirconium phosphate layer releases sodium and hydrogen. Since the replacement of magnesium, calcium, and potassium in the dialysate is generally proportioned at a constant rate, the sodium dynamics of the dialysate are essentially controlled by ammonium adsorption, and the latter can vary considerably from treatment to treatment and from patient to patient. Ammonium is generated from enzymatic digestion of urea, and the amount of urea presented to the cartridge will depend on the patient's initial urea concentration as well as on the rate of transfer of urea from the blood to dialysate in the dialyzer. The amount of urea removed from blood is highest during the initial part of a dialysis session. Hence, it is during this early time period of the dialysis session that the rate of ammonium production via urease in the cartridge is highest, and when the rate of ammonium exchange for sodium is also highest. Accordingly, the dialysate sodium increase will be highest during the initial part of the dialysis session.

Given the anticipated increase in the concentration of sodium exiting the sorbent cartridge, especially during the initial portion of a treatment, prevention of patient sodium loading during sorbent dialysis is managed in two ways: First, the sodium concentration of the prime solution is set below the desired dialysate sodium level that will be present during much of the treatment. The lower dialysate sodium concentration

that this approach provides is quite transient, owing to the addition of sodium to the recirculating dialysis solution by the sorbent cartridge during the initial part of dialysis, as discussed above. The second approach to prevent sodium loading during sorbent dialysis is to add small volumes of water to the dialysate as dialysis progresses, owing to continued addition of sodium to the dialysate by the ammonium/sodium exchange in the cartridge. The automated controlled addition of water to the recycled dialysis solution during dialysis maintains the dialysate sodium concentration at an appropriate level, and sodium transfer to the patient is prevented.

2. **Adjusting dialysis solution bicarbonate.** Bicarbonate in the dialysis solution originates from chemicals added to make up the prime solution, and from the cartridge via urea hydrolysis (which forms ammonium carbonate), anion exchange, and via the sodium bicarbonate layer. In this system, the hydrolytic decomposition of urea results in ammonium and bicarbonate ions. Figure 19.2 illustrates the changes that take place in the dialysate as well as plasma bicarbonate levels during a typical sorbent dialysis treatment with the 6 layer sorbent cartridge. The dialysate bicarbonate concentration is slightly elevated at the beginning of treatment. Hydrolysis of urea in layer 2 produces ammonium bicarbonate. In exchange for sodium ions, the zirconium phosphate layer releases hydrogen ions, which combine with carbonate ions to produce carbonic acid and CO_2 . Breakdown of 10 g of urea generates approximately 150 mEq of bicarbonate. The net effect depends on the hydrogen ions available from the zirconium phosphate layer and the patient's initial blood urea nitrogen (BUN), which drives the balance between carbonic acid and bicarbonate. Bicarbonate might actually decrease initially, but as treatment proceeds neutralization of hydrogen ions results in increased dialysate bicarbonate that is transferred to the patient (Fig. 19.2).

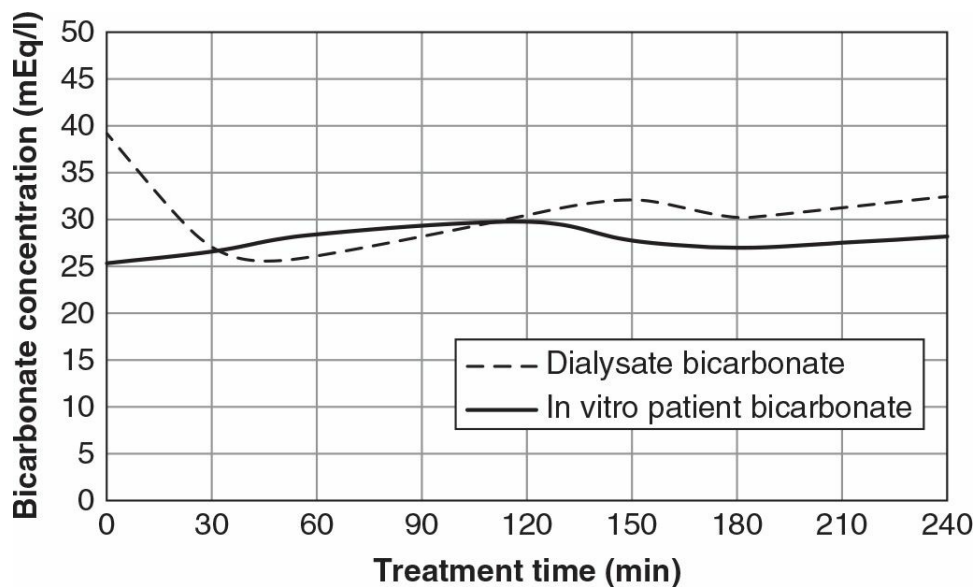

FIGURE 19.2 *In vitro* patient and dialysate bicarbonate profiles in sorbent dialysis with the 6-layer cartridge.

II. SORBENT-BASED DIALYSIS MACHINES

- A. **The REDY system.** In 1973, the first sorbent-based hemodialysis machine, the Recirculating Dialysate System (REDY), and sorbent cartridges were introduced to the market. By 1975, an estimated 10,000 hemodialysis treatments per month were utilizing the REDY system. The REDY system provided mobility not available with single-pass systems. The self-contained dialysis system was small enough to be transported on a standard hospital utility cart and was used primarily for acute and home hemodialysis. Manufacturing of the REDY system was discontinued in 1994.
- B. **The Allient system.** In 2006, the Allient Sorbent Hemodialysis System (Allient System), developed by Renal Solutions, Warrendale, PA, received FDA clearance. The Allient System combined sorbent technology with a unique, pressure-controlled blood movement system. As with previous sorbent-based devices, it was a completely self-contained, transportable machine. The Allient System was never fully commercialized, and Renal Solutions was purchased by Fresenius Medical Care, Waltham, MA, in late 2007.
- C. **The Fresenius 2008 Sorbent System.** The Fresenius 2008 Sorbent System received FDA clearance in August 2010. It was comprised of two separate components: a modified Fresenius 2008K hemodialysis machine and a SORB module. The SORB module was a sorbent dialysate regenerative system located on the side of the 2008 machine platform that replaced the single-pass dialysate delivery system. The Fresenius 2008 Sorbent System used the standard blood-tubing configurations of the 2008 series dialysis machine platform, and delivered the same range of blood flow rates. In the SORB module, as with the previously described sorbent dialysis systems, spent dialysate and ultrafiltrate exited the dialyzer. However, a portion of the spent dialysate (equal to the volume removed by ultrafiltration) was removed from the dialysate and sent to a drain jug. The sodium concentration of the remaining spent dialysate was automatically adjusted by addition of either a sodium chloride solution or water to maintain the prescribed sodium level. The sodium-adjusted spent dialysate was then returned to the sorbent cartridge for purification. The final regenerated dialysis solution was kept in a disposable reservoir bag, from which it was returned to the dialyzer as needed. An integrated ammonia sensor monitoring the cartridge effluent notified the operator of cartridge saturation. A guide provided the prescribing physician with information necessary to target a desirable end-dialysis sodium bicarbonate dialysate range and the desired sodium bicarbonate transfer to the patient.
- D. **The Fresenius PAK Sorbent Hemodialysis System.** The PAK system, currently under development by Fresenius Medical Care, is being designed as a portable, transportable, and simple-to-use sorbent system weighing less than 70 lb. The device will include two units: a pump and a reservoir. The pump will be located above the reservoir, and both units will lock together. When the system is turned off, releasing the lock will allow separation of the two units for transport. A single-use blood/dialysate cassette will be mounted in the pump unit. This disposable cassette will combine the blood-tubing set and dialysate circuit and will snap into place, simplifying setup. A dialyzer will be connected to the tubing cassette, providing an integrated and sterile unit. A disposable reservoir bag, capable of holding 11 L of dialysis solution, will rest in a heated pan in the reservoir unit and will complete the dialysate circuit. All dialysate and blood contact surfaces will be external to the system, thereby eliminating the necessity for any internal system cleaning or disinfection between

treatments. During treatment, spent dialysate including ultrafiltrate will exit the dialyzer (Fig. 19-3). Dilution water will automatically be added to the dialysate to maintain a controlled sodium level. The sodium-adjusted dialysate will be returned to the sorbent cartridge for purification. Dialysate flow rates of 300 to 400 mL/min will be available, and the blood flow rate will be adjustable from 100 to 500 mL/min.

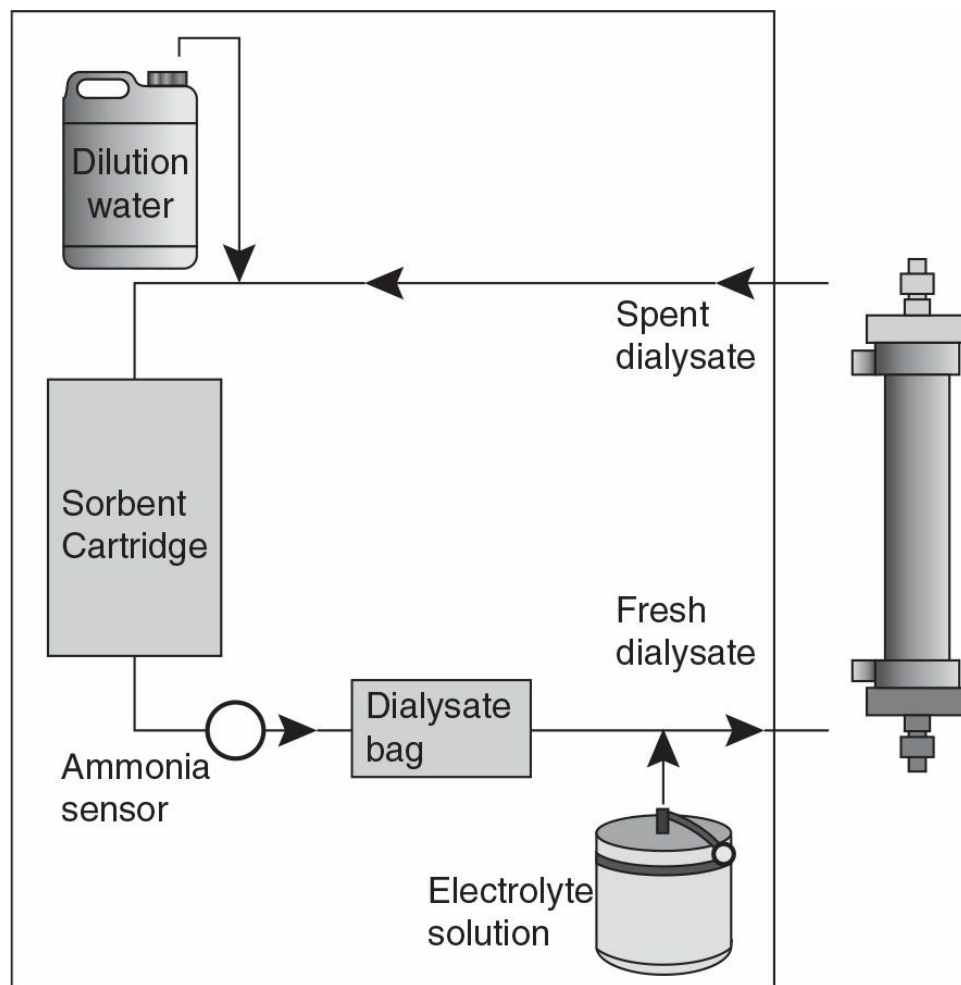

FIGURE 19.3 Schematic representation of dialysate flow path for the Fresenius portable sorbent system.

References and Suggested Readings

- Agar JWM. Review article: understanding sorbent dialysis systems. *Nephrology*. 2010;15:406–411.
- Ash SR. The allient dialysis system. *Semin Dial*. 2004;17:164–166.
- Hansen SK. Advances in sorbent dialysis. *Dial Transplant*. 2005;34:648–652.
- McGill RL, et al. Sorbent hemodialysis: clinical experience with new sorbent cartridges and hemodialyzers. *ASAIO J*. 2008;54:618–621.
- Organon Teknika Corp. *Sorbent Dialysis Primer*. 3rd ed. Durham, NC: Organon Teknika Corp.;1991.
- Roberts M. The regenerative dialysis (REDY) sorbent system. *Nephrology*. 1998;4:275–278.
- Tarrass F, et al. Water conservation: an emerging but vital issue in hemodialysis therapy. *Blood Purif*. 2010;30:181–185.
- Welch PG. Deployment dialysis in the U.S. Army: history and future challenges. *Military Medicine*. 165:737–741.

Hemodialysis, hemoperfusion, and peritoneal dialysis (PD), particularly the first two procedures, can be useful adjuncts in the management of drug overdose and poisoning. However, these treatments should be applied selectively, as part of the general approach to the poisoned patient, which include supportive therapy, decontamination, elimination enhancement, and antidotes (Kulig, 1992). A review of data from the 2012 report of the American Association of Poison Control Centers shows that MDAC (multiple-dose activated charcoal) and alkalization treatments far outnumber treatments by hemodialysis, and these in turn far outnumber treatments using hemoperfusion, with only 61 hemoperfusion treatments being reported versus 2,324 treatments using dialysis (Mowry, 2013).

I. DIALYSIS AND HEMOPERFUSION

A. **Indications.** Extracorporeal techniques should be considered when the conditions listed in Table 20.1 apply. Any procedure used in poisoning treatment should have a greater effect on drug elimination than that which occurs spontaneously. Early use of dialysis or hemoperfusion can be considered if the serum levels of a drug or poison are found to be increased to values known to be associated with death or serious tissue damage. Critical serum concentrations for several drugs are listed in Table 20.2. The information given in Tables 20.1 and 20.2 only represents a set of recommendations; the decision to institute dialysis or hemoperfusion must be made on an individual basis. In addition to providing extracorporeal drug elimination, dialysis can provide essential supportive care to poisoned patients with multiorgan or kidney injury. The EXTRIP (EXtracorporeal Treatment In Poisoning) work group is currently drafting guidelines for the use of blood purification in the context of overdose. Their publication should help to standardize management for these complex patients (Lavergne, 2012).

B. Choice of therapy

1. **Peritoneal dialysis** is not very effective in removing drugs from the blood, with maximal poison clearance rarely above 15 mL/min (about one-tenth of what usually can be reached with hemodialysis). Nevertheless, when hemodialysis is difficult to institute quickly, such as in small children, a prolonged session of PD can be a valuable adjunctive treatment for poisoning. Also, under certain conditions, such as in the hypothermic-poisoned patient, PD may be useful, as it may also be used to help in core

TABLE

20.1

Criteria for Consideration of Dialysis or Hemoperfusion in Poisoning

1. Progressive deterioration despite intensive supportive therapy
2. Severe intoxication with depression of midbrain function leading to hypoventilation, hypothermia, and hypotension
3. Development of complications of coma, such as pneumonia or septicemia, and underlying conditions predisposing to such complications (e.g., obstructive airways disease)
4. Impairment of normal drug excretory function in the presence of hepatic, cardiac, or renal insufficiency
5. Intoxication with agents with metabolic and/or delayed effects (e.g., methanol, ethylene glycol, and paraquat)
6. Intoxication with an extractable drug or poison, which can be removed at a rate exceeding endogenous elimination by liver or kidney

TABLE

20.2

Serum Concentrations of Common Poisons in Excess of Which Hemodialysis (HD) or Hemoperfusion (HP) Should Be Considered

Drug	Serum Concentration ^a		Method of Choice
	(mg/L)	(mcmol/L)	
Phenobarbital	100	430	HP, HD
Glutethimide	40	180	HP
Methaqualone	40	160	HP
Salicylates	800	4.4 mmol/L	HD
Theophylline	40	220	HP, HD
Paraquat	0.1	0.4	HP > HD
Methanol	500	16 mmol/L	HD
Meprobamate	100	460	HP

^aSuggested concentrations only: Clinical condition may warrant intervention at lower concentrations (e.g., in mixed intoxications).

2. **Hemodialysis** is the therapy of choice for water-soluble drugs, especially those of low molecular weight along with a low level of protein binding, as such compounds will diffuse rapidly across the dialyzer membrane. Examples are ethanol, ethylene glycol, lithium, methanol, and salicylates. Water-soluble drugs that have high molecular weights (e.g., amphotericin B [MW 9,241] and vancomycin [MW 1,500]) diffuse across dialyzer membranes more slowly and are less well removed; removal rate is accelerated by use of high-flux membranes and hemodiafiltration. Hemodialysis is not very useful in removing lipid-soluble drugs (e.g., amitriptyline) with large volumes of distribution or drugs with extensive protein binding.
3. **Hemoperfusion** is a process whereby blood is passed through a device containing adsorbent particles. Most commonly, the adsorbent particles are activated charcoal or

some sort of resin. Although hemoperfusion may be more effective than hemodialysis in clearing the blood of many protein-bound drugs (because the charcoal or resin in the cartridge will compete with plasma proteins for the drug, adsorb the drug, and thereby remove it from the circulation), modern high-flux dialyzers may also perform in a similar manner. Hemoperfusion will remove many lipid-soluble drugs from the blood much more efficiently than hemodialysis. In the United States, hemoperfusion cartridges are expensive and have been discontinued by some manufacturers, and with a short shelf life of 2 years, may not be available in certain urban cities (Shalkam, 2006). If a drug is equally well removed from the blood by hemoperfusion and hemodialysis, then hemodialysis is preferred: potential problems of cartridge saturation are avoided, and the incidence of hemoperfusion complications such as thrombocytopenia and leukopenia is reduced; plus, with hemodialysis, any coexisting acid–base or electrolyte disturbances can be treated.

4. **Continuous hemodiafiltration, hemoperfusion.** Prolonged continuous treatment is potentially useful in drugs with moderately large volumes of distribution (V_D) and slow intercompartmental transfer times, because posttherapy rebound of plasma drug levels is avoided. Clear advantages of continuous treatment over repeated conventional treatments for drug rebound remain to be demonstrated. Continuous hemoperfusion has been used successfully in theophylline and phenobarbital toxicity, and continuous hemodiafiltration has been used in ethylene glycol and lithium toxicity (Leblanc, 1996).
- C. **Toxicokinetics.** Poisons have various molecular characteristics that make them more or less amenable to extracorporeal removal. Dialyzability of a poison is possible only if it can be extracted from the plasma compartment, if a significant proportion of its total body stores can be eliminated, and if extracorporeal clearance contributes a significant amount to total clearance. Removal from the plasma compartment is best reflected by the dialyzer extraction ratio, which can be calculated as $(A-V)/A$, where A represents the inflow (prefilter or precolumn) concentration of the solute to be removed, and V represents the dialyzer outflow concentration. The amount of toxin that can be removed by extracorporeal treatment is greatly affected by the volume of its distribution in the body. The ratio of extracorporeal removal to endogenous removal depends on the endogenous clearance of a particular poison and the current condition of the body organs (liver and/or kidney) that normally participate in endogenous removal. The following factors will influence poison dialyzability (Lavergne, 2012):
1. **Molecular weight.** Extracorporeal modalities have different molecular weight cutoffs; techniques that use diffusion such as hemodialysis usually have an approximate cutoff of 5,000 Da, while convection- and adsorption-based techniques are capable of removing poisons that are in excess of 50,000 Da in size. Plasmapheresis can remove poisons that are up to 1,000,000 Da in size.
 2. **Protein binding.** Since the poison–protein complex cannot freely pass through dialyzers or hemofilters, only poisons that are largely unbound (or free) can be removed by these techniques. However, at higher concentration (such as in overdose), protein binding of a drug can become saturated; under such conditions, a higher proportion of the drug is unbound or “free,” which is then available for removal by extracorporeal treatment.

3. **Volume of distribution.** V_D is the theoretical volume into which a drug is distributed. Heparin, for example, a drug confined to the blood compartment, has a V_D of approximately 0.06 L/kg. Drugs distributed primarily in the extracellular water (e.g., salicylates) will have a V_D of approximately 0.2 L/kg. Some drugs will have V_D values exceeding the volume of total body water because they are extensively bound to, or stored in, tissue sites. With drugs that have a high V_D (e.g., digoxin, tricyclics), the amount of drug present in the blood represents only a small fraction of the total body load. Thus, even if a hemodialysis or hemoperfusion treatment extracts most of the drug present in the blood flowing through the extracorporeal circuit, the amount of drug removed during a single treatment session will represent only a small percentage of the total body drug burden. Subsequently, additional drug will enter the blood from tissue stores, sometimes causing a recurrence of the toxic manifestations. On the other hand, even transiently lowering the blood concentration of many drugs may mitigate certain important toxic effects of these agents. Hence, hemodialysis or hemoperfusion can sometimes effectively reduce drug toxicity even when the V_D is large.
4. **Endogenous clearance.** Extracorporeal removal usually is not indicated when endogenous clearance by metabolism and elimination is expected to exceed the rate of exogenous elimination. This explains why hemodialysis is not indicated for poisons like cocaine or toluene. Similarly, the presence of kidney impairment for renally eliminated poisons (e.g., lithium) will make extracorporeal removal more important.

D. Technical points

1. **Vascular access for hemodialysis or hemoperfusion in poisoning.** In patients without permanent vascular access in place, percutaneous cannulation of a large central vein using a dialysis catheter is required.
2. **Choice of hemodialyzer.** High-flux, high-efficiency dialyzers with high urea clearances should generally be used. The development of high-cutoff hemodialysis membranes (with increased pore size of 8 to 10 nm) may allow clearance of larger toxins and molecules as large as 50 to 60 kDa (e.g., Fab fragments).
3. **Choice of a hemoperfusion cartridge.** Some of the available cartridges are listed in Table 20.3. Typical sorbents are activated carbons (charcoals), ion exchange resins, or nonionic exchange macroporous resins. Sorbent particles have been rendered biocompatible by coating the surface with a polymer membrane. The cartridges contain various amounts of sorbent, the smaller ones being designed for pediatric use. A detailed comparative evaluation of in vivo performance of the various brands of cartridges has been published (Ghannoum, 2014).
4. **The hemoperfusion circuit.** The hemoperfusion circuit is similar to the blood side of a hemodialysis circuit and includes an air detector and a venous air trap. Standard hemodialysis blood pumps and machines (without use of dialysis solution) are often used to drive the blood through the tubing and cartridge.
5. **Priming the hemoperfusion circuit.** Setup and priming with saline or dextrose differ depending on the brand of cartridge used, and the manufacturer's literature should be consulted in all instances. The hemoperfusion cartridge must be primed in a vertical

position with the arterial (blood inlet) side facing downward.

6. **Heparinization during hemoperfusion.** Once the cartridge has been primed, a bolus dose of heparin (usually 2,000–3,000 units) is administered into the arterial line, the cartridge is kept inlet side down, and blood flow through the cartridge is begun. As a rule, because of some adsorption on the sorbent, more heparin may be required for a hemoperfusion treatment (e.g., approximately 6,000 units or 10,000 units for charcoal and resin, respectively, per session) than for hemodialysis. Heparin should be given in amounts sufficient to maintain the patient's activated clotting time (ACT) or partial thromboplastin time at about twice the normal value.

TABLE

20.3

Some Available Hemoperfusion Devices (May Vary by Country)

Manufacturer	Device	Sorbent Type	Amount of Sorbent	Polymer Coating
Asahi ^a	Hemosorba	Charcoal	170 g	Poly(2-hydroxyethyl methacrylate) (poly-HEMA)
Gambro	Adsorba 150/300c	Charcoal	150/300 g	Cellulose acetate
Braun ^a	Haemoresin	Resin XAD-4 Amberlite	350 g	None

Note: Smaller devices for use in children.

^aNot available in the US

7. **Duration of hemoperfusion.** A single 3-hour treatment will substantially lower the blood levels of most poisons for which hemoperfusion is effective. More prolonged use of a hemoperfusion cartridge is inefficient, because the charcoal tends to become saturated. Replacement of saturated devices with fresh ones is not usually required, and any rebound in blood drug concentrations consequent to tissue release can be treated with a second hemoperfusion session. On the other hand, a continuous hemoperfusion treatment may need to be prolonged for several days until clinical improvement or a nontoxic blood level is achieved. Hemoperfusion devices may need to be changed every 4 hours in the course of continuous treatment.

E. **Complications.** All extracorporeal techniques require vascular access through a central line, and this procedure itself is subject to complications.

1. **Hemodialysis**

- a. **Hypophosphatemia.** In contrast to end-stage renal disease (ESRD), patients being dialyzed for poisoning often do not have an elevated plasma phosphate value. Because phosphate is not present in standard dialysis solutions, intensive dialysis can severely lower the plasma phosphate level, resulting in respiratory insufficiency and other complications. Hypophosphatemia during dialysis can be avoided by supplementing the dialysis solution with phosphate as discussed in Chapter 10.
- b. **Alkalemia.** Standard hemodialysis solutions contain unphysiologically high

concentrations of bicarbonate and they also contain bicarbonate-generating base in the form of acetate or citrate, as they have been designed to correct metabolic acidosis. Performing dialysis for poisoning in a patient with metabolic or respiratory alkalosis can provoke or worsen alkalemia unless the dialysis solution bicarbonate concentration is appropriately reduced.

- c. **Disequilibrium syndrome in acutely uremic patients.** In patients with both severe uremia and poisoning, it may be dangerous to carry out a prolonged high-clearance dialysis session initially. During a dialysis treatment for a metformin-associated lactic acidosis in a markedly uremic patient, enrichment of dialysate with an appropriate amount of urea in an attempt to attenuate the manifestations of the disequilibrium syndrome has been successfully performed (Doorenbos, 2001).
2. **Hemoperfusion.** Mild transient thrombocytopenia and leukopenia can occur, but cell counts usually return to normal within 24 to 48 hours following a single hemoperfusion. Adsorption or activation of coagulation factors has also been observed rarely and may be clinically significant in patients with liver failure.
3. **Continuous therapy.** Fluid and electrolyte imbalances may be potential problems and require frequent monitoring. Prolonged anticoagulation may predispose to bleeding.

II. MANAGEMENT OF POISONING WITH SELECTED AGENTS

- A. **Acetaminophen (MW 151 Da).** Activated charcoal should be given to patients presenting within 4 hours of ingestion. Serum levels should be measured and plotted using the Rumack–Matthew nomogram to establish the risk of hepatotoxicity and need for *N*-acetylcysteine (NAC) therapy. Concomitant ingestion of moderate amounts of ethanol markedly increases the risk of liver damage. If serum acetaminophen levels are above 150 mg/L (1.0 mmol/L) at 4 hours, the likelihood of toxicity is high and NAC (PO or IV) should be given. NAC, by increasing reduced glutathione stores, prevents the accumulation of toxic acetaminophen by-products. Its efficacy in preventing liver failure declines if started more than 10 hours after ingestion, but NAC is still recommended even after 24 hours. Although acetaminophen is moderately water-soluble and is minimally protein-bound and thus removed by dialysis or hemoperfusion, NAC remains the treatment of choice.
- B. **Aspirin (acetylsalicylic acid, MW 180 Da).** In adults, severe aspirin poisoning is usually accompanied by metabolic acidosis with respiratory alkalosis, whereas in children, isolated metabolic acidosis is often encountered. The appearance of central nervous system (CNS) symptoms is a sign of severe poisoning. The Done nomogram (Done and Temple, 1971), relating serum levels and time of ingestion to outcome, gives some idea of the seriousness of salicylate poisoning in children, but is less used in adult poisoning. MDAC should be initiated and urine alkalization carried out if substantial urine output is achievable, particularly when symptoms are present and serum salicylate levels are >50 mg/dL (2.8 mmol/L). Aspirin has a V_D of only 0.15 L/kg. Despite the fact that the drug is about 50% protein-bound, aspirin is well removed by hemodialysis. Hemodialysis should be considered when the serum level exceeds 90 mg/dL (6.5 mmol/L) or there is evidence of marked acidemia, neurologic involvement (neurologic symptoms, hyperthermia, seizures) or noncardiogenic pulmonary edema.

C. **Barbiturates.** Toxic serum levels of phenobarbital (MW 232 Da) are over 3 mg/dL (130 μ mol/L), and coma begins to appear at levels of 6 mg/dL (260 μ mol/L). MDAC should be considered as first-line therapy, and alkalinization of the urine may help remove long-acting barbiturates such as phenobarbital. Phenobarbital is 50% protein-bound, but its V_D is only 0.5 L/kg; the drug is well removed by either hemodialysis or hemoperfusion. Hemodialysis should be contemplated when coma is prolonged, especially when complications of coma, such as pneumonia, threaten. Removal with hemodialysis using a synthetic membrane dialyzer equals that of hemoperfusion (Palmer, 2000).

D. **Digoxin (MW 781 Da).** The probabilities of digoxin-induced arrhythmias are 50% and 90% at serum levels of 2.5 and 3.3 ng/mL (3.2 and 4.2 nmol/L), respectively. Treatment includes correction of hypokalemia, hypomagnesemia, and alkalosis and administration of oral-activated charcoal.

The V_D of digoxin is large (8 L/kg in normal patients, 4.2 L/kg in dialysis patients), and the drug is 25% protein-bound. For these reasons, only 5% of the body load will be removed by a 4-hour hemodialysis treatment. Although hemoperfusion is more effective and has been shown to improve symptoms, it is not routinely recommended in the treatment of digoxin toxicity as the V_D of the drug is so large that total body clearance is limited. Plasmapheresis performed soon after Fab fragment administration promotes removal of the Fab–digoxin complexes (Zdunek, 2000), and high-cutoff membranes such as Theralite can be used for this purpose also (Fleig, 2011). Most authors recommend an additional Fab treatment if toxicity recurs. In dialysis patients, Fab therapy remains preferred over hemoperfusion or plasmapheresis. Although Fab has been used successfully in patients with coexisting renal failure, digoxin may be released from the Fab–digoxin complex, leading to a rebound in toxicity, perhaps requiring a second treatment (Ujhelyi, 1993).

E. **Toxic alcohols.** Ethylene glycol and methanol are the commonest causes of fatal toxic alcohol poisoning. Ethylene glycol is found in antifreeze solutions, deicing solutions, hydraulic brake fluid, foam stabilizers, and chemical solvents. Methanol is found in windshield washing fluids, paints, solvents, copier fluids, and illegally manufactured (wood) alcohol. Methanol and ethylene glycol are relatively nontoxic, but both are metabolized via the enzyme alcohol dehydrogenase (ALDH) to produce the toxic metabolites formic acid and glycolic acid, respectively. In ethylene glycol poisoning, glycolate is further metabolized to oxalate, which can cause acute kidney injury

Coingestion of ethanol may delay formation of toxic metabolites and its associated clinical features. Poisonings with toxic alcohols should be suspected in patients with unexplained metabolic acidosis accompanied by increases in anion and osmolal gaps. However, an elevated anion gap and an elevated osmolal gap are rarely concomitantly present early or very late after ingestion of toxic alcohols. If a toxic alcohol has not been metabolized, the osmolal gap but not the anion gap will be increased. On the other hand, if a toxic alcohol has undergone complete metabolism, the anion gap but not the osmolal gap will be elevated. Therefore, a normal osmolal or anion gap does not eliminate the possibility of significant toxic alcohol ingestion.

Alcohols are rapidly absorbed and have the same V_D as water. MDAC or

gastrointestinal decontamination has a limited role in the management of alcohol poisoning. There is a competitive inhibition for the ALDH enzyme between either ethanol or fomepizole (4-methylpyrazole) on the one hand and a toxic alcohol on the other. Fomepizole has a greater affinity for ALDH than ethanol. Either ethanol or fomepizole should be given as soon as possible after ingestion to delay the conversion to toxic metabolites and to allow time for the disposal of the parent drug and its toxic metabolites that might have been formed, through the urinary, metabolic, and dialytic routes. Currently, there are insufficient data to define the relative roles of fomepizole and ethanol in the treatment of toxic alcohol poisoning. Ethanol can cause CNS depression, phlebitis, hypoglycemia, and respiratory depression, and requires close monitoring of serum ethanol levels. Fomepizole has advantages over ethanol in terms of validated efficacy, predictable pharmacokinetics, ease of administration, and fewer adverse effects. Ethanol has advantages over fomepizole in terms of clinical experience and lower drug cost (cost advantage upward of 1:100). Fomepizole is probably safer in children and pregnant women. For milder cases with adequate renal function, ethanol infusions alone (without extracorporeal treatment) over several days in the intensive care unit can be difficult to manage. In such patients a long period of intensive care monitoring can be avoided when treating with fomepizole.

In mild intoxications in which there is little evidence of metabolic breakdown of toxic alcohols (i.e., without metabolic acidosis) and when endogenous routes of elimination are intact, in the course of treatment with ethanol or fomepizole, the patient should be expected to recover. On the other hand, when there is evidence of presence of breakdown products of these alcohols; e.g., with resultant metabolic acidosis, and in the presence of poor renal function, removal of the toxic alcohols and their deleterious metabolites by hemodialysis is mandatory, as neither ethanol nor fomepizole has the capacity to dispose of these substances from the body. Hemodialysis is highly effective in rapidly removing both toxic alcohols and their metabolites and in correcting metabolic abnormalities. Thus, the risks and costs of prolonged hospitalization and the cost of fomepizole must be weighed against those of hemodialysis. Since hemodialysis is so efficient in removing the toxic alcohols, the prolonged intensive care monitoring required for ethanol administration is less necessary if hemodialysis is added to the treatment regimen. On account of its lower cost, the use of ethanol may have an economic incentive in developing countries. Overall, prognosis correlates better with the severity of acidosis and toxic metabolite concentrations than with the parent alcohol concentration.

1. **Ethylene glycol (MW 62 Da).** The first phase of toxicity due to ethylene glycol begins <1 hour after ingestion and is characterized by CNS depression similar to ethanol intoxication. In severe poisoning, this phase can result in coma and seizures and can last 12 hours. The second phase is due to the toxic effects of the metabolite, glycolic acid, on the cardiopulmonary system with the development of cardiac and respiratory failure 12 hours after ingestion. A severe metabolic acidosis commonly occurs. After 24 to 48 hours, renal failure often supervenes as a result of oxalate precipitation in the kidney, delaying the excretion of the poison. This is characterized by flank pain, hypocalcemia, and acute tubular necrosis accompanied by oxalate crystals in the urine.

Early aggressive management of acidosis with sodium bicarbonate is essential. Indications for the administration of an antidote (ethanol or fomepizole) are shown in Table 20.4. Indications for hemodialysis are shown in Table 20.5. Traditionally, an ethylene glycol level above 50 mg/dL (8.1 mmol/L) is an indication for dialysis. In the absence of both renal dysfunction and metabolic acidosis, the use of fomepizole may obviate the need for dialysis, even in patients with serum ethylene glycol levels above 50 mg/dL. However, if patients with serum levels of ethylene glycol above 50 mg/dL are not treated with hemodialysis but only with ethanol or fomepizole, the acid–base status should be monitored very closely and hemodialysis initiated promptly if acidosis develops. The dosing schedule for ethanol or fomepizole and the dose adjustments for hemodialysis are shown in Tables 20.6 and 20.7. Hemodialysis should be performed until acidosis has resolved and the ethylene glycol levels are below 20 mg/dL (3.2 mmol/L). Redistribution of ethylene glycol may result in rebound elevation of ethylene glycol levels within 12 hours after cessation of dialysis, and repeat dialysis may be necessary. Thus, serum osmolality, electrolytes, and acid–base status should be monitored closely within 24 hours after dialysis. Pyridoxine (50 mg IM four times daily) and thiamine (100 mg IM four times daily) should be considered to increase the metabolism of glyoxylate. In addition, judicious intravenous fluids should be given to prevent calcium oxalate crystal deposition in the kidneys and acute renal failure. Hypocalcemia, the effects of which may be worsened by bicarbonate treatment, (increasing blood pH will lower the ionized calcium) should be corrected if this is symptomatic or severe. It is uncertain whether correction of hypocalcemia significantly increases calcium oxalate precipitation in tissues.

TABLE

20.4

Indications for Treatment of Ethylene Glycol or Methanol Poisoning with Ethanol or Fomepizole

1. Documented plasma ethylene glycol or methanol concentrations >20 mg/dL *or*
2. Documented recent (hours) history of ingestion of toxic amounts of ethylene glycol or methanol and osmolal gap >10 mmol/kg
or
3. History or strong clinical suspicion of ethylene glycol or methanol poisoning and at least two of the following criteria:
 - Arterial pH <7.3
 - Serum bicarbonate <20 mmol/L
 - Osmolal gap >10 mmol/kg^a
 - Urinary oxalate crystals (in the case of ethylene glycol) or visual signs or symptoms (in the case of methanol) present

^aLaboratory analysis by freezing point depression only.

al. American Academy of Clinical Toxicology practice guidelines on the treatment of methanol poisoning. *J Toxicol Clin Toxicol*. 2002;40:415.

TABLE

20.5

Indications for Hemodialysis in Patients with Severe Ethylene Glycol or Methanol Poisoning

1. Severe metabolic acidosis (pH <7.25–7.30)
2. Renal failure
3. Visual symptoms/signs
4. Deteriorating vital signs despite intensive supportive care
5. Ethylene glycol or methanol levels >50 mg/dL unless fomepizole is being administered and patient is asymptomatic with a normal pH^a

^aSuch patients should be monitored very closely, and hemodialysis should be initiated if acidosis develops. Withholding of dialysis in such patients may result in prolongation of hospitalization. Modified from Barceloux DG, et al. American Academy of Clinical Toxicology practice guidelines on the treatment of ethylene glycol poisoning. *J Toxicol Clin Toxicol*. 1999;37:537; Barceloux DG, et al. American Academy of Clinical Toxicology practice guidelines on the treatment of methanol poisoning. *J Toxicol Clin Toxicol*. 2002;40:415.

TABLE

20.6

Guidelines for Use of Ethanol in Toxic Alcohol Poisonings

1. Loading dose: 0.6 g/kg [intravenous 10% ethanol in D5W (7.6 mL/kg) or 43% oral solution or 86 proof undiluted liquor (34 g ethanol/dL) 1.8 mL/kg]
2. Maintenance dose:
 - In alcoholic patients 154 mg/kg per hour
 - In nonalcoholic patients 66 mg/kg per hour
 - Double dose during hemodialysis or enrich dialysate with 100 mg/dL ethanol^a
 - Double dose if given orally with charcoal
3. Monitor serum ethanol concentrations every 1–2 hours and adjust infusion rate to maintain serum ethanol level of 100–150 mg/dL. Thereafter, monitor ethanol levels every 2–4 hours
4. Continue until methanol or ethylene glycol concentrations are <20 mg/dL and patient is asymptomatic with normal arterial pH

^aRerom Wadgyar A, et al. Treatment of acute methanol intoxication with hemodialysis. *Am J Kidney Dis*. 1998;31:897.

TABLE

20.7

Guidelines for Use of Fomepizole in the Treatment of Ethylene Glycol and Methanol Poisoning

1. Loading dose: 15 mg/kg IV in 100 mL 0.9% saline over 30 minutes to 1 hour
 2. Maintenance dose: 10 mg/kg every 12 hours for four doses, then 15 mg/kg every 12 hours
 3. Dose adjustments during hemodialysis: 15 mg/kg every 4 hours or 1–1.5 mg/kg per hour infusion during dialysis
 4. Continue until methanol or ethylene glycol concentrations are <20 mg/dL and patient is asymptomatic with normal arterial pH
-

Modified from Barceloux DG, et al. American Academy of Clinical Toxicology practice guidelines on the treatment of ethylene glycol poisoning. *J Toxicol Clin Toxicol*. 1999;37:537; Barceloux DG, et al. American Academy of Clinical Toxicology practice guidelines on the treatment of methanol poisoning. *J Toxicol Clin Toxicol*. 2002;40:415.

2. **Methanol (MW 32 Da).** Methanol poisoning causes early temporary CNS depression followed by a latent period lasting 6 to 24 hours before the development of metabolic acidosis and visual symptoms. The latter, due to formic acid accumulation, include blurred vision, decreased visual acuity, photophobia, visual field defects, or even complete blindness. Early signs include optic disk hyperemia and decreased pupillary reflexes to light.

Initial management is similar to that for ethylene glycol toxicity, including the correction of acidosis with intravenous sodium bicarbonate to pH 7.35 to 7.4. Ethanol or fomepizole should be administered to prevent formation of formic acid according to indications (Table 20.4). Hemodialysis should be considered (Table 20.5) when there is significant metabolic acidosis (pH <7.25–7.3), abnormalities of vision, deteriorating vital signs, renal failure, or electrolyte abnormalities unresponsive to conventional therapy. Serum methanol concentration >50 mg/dL (15.6 mmol/L) is often used as an indication for hemodialysis. High serum methanol concentrations may require several days of treatment with ethanol or fomepizole. If a patient with high serum concentrations of methanol is not treated with hemodialysis, acid–base status should be monitored closely, and hemodialysis should be initiated as soon as acidosis develops. Hemodialysis should be continued until acidosis is corrected and serum methanol levels are <20 mg/dL (6.3 mmol/L). When methanol concentrations are very high, dialysis for 18 to 21 hours may be required. In some patients with normal renal function receiving ethanol or fomepizole, dialysis may not be necessary once serum methanol falls below 50 mg/dL and anion gap acidosis is corrected. Ophthalmologic abnormalities may persist transiently or permanently and should not be considered an indication to continue dialysis. Redistribution of methanol may result in elevation of methanol concentrations after dialysis ceases, and repeat dialysis may be necessary. Consequently, serum osmolality and acid–base status should be monitored frequently for the first 24 to 36 hours after hemodialysis ceases. If dialysis is initiated, doses of ethanol or fomepizole should be increased (however, in the case of ethanol therapy, if ethanol is also used to enrich the dialysate, the systemic doses need not be increased) (Tables 20.6 and 20.7). Formic acid is converted by 10-formyl tetrahydrofolate

synthetase to carbon dioxide and water. Folinic acid IV (1 mg/kg [up to 50 mg] in 5% dextrose over 30–60 minutes every 4 hours) should be given to enhance formic acid metabolism until methanol and formate have been cleared. If folinic acid is unavailable, folic acid can be used.

3. **Isopropanol (MW 60 Da).** Isopropanol (isopropyl alcohol) is found in rubbing alcohol, antifreeze, and frost remover. Isopropanol is a common cause of poisoning but is only occasionally fatal. Isopropanol is oxidized by ALDH to acetone. Unlike ethylene glycol and methanol, most of the clinical effects of isopropanol intoxication are due to the parent compound. Gastrointestinal and CNS symptoms, including confusion, ataxia, and coma, occur in 1 hour. Hypotension due to cardiac depression and vasodilatation can occur in severe intoxication. Hypoglycemia can occur. Acidosis is rare in the absence of severe hypotension. Therefore, a high serum osmolal gap without acidosis in association with an increased urinary or serum acetone level is highly suggestive of isopropanol poisoning. Supportive treatment is usually all that is necessary. Inhibition of ALDH is not warranted because acetone is less toxic than the parent compound. Hemodialysis might be considered if the isopropanol levels are >400 mg/dL (67 mmol/L) and significant CNS suppression, renal failure, or hypotension exists.
 4. **Other alcohols.** Poisonings with other alcohols used in a variety of industrial and household products have been reported with much less frequency. Metabolism of the parent compound may lead to the generation of toxic metabolites. Propylene glycol (MW 76 Da) is an excipient often used in pharmaceuticals such as lorazepam and nitroglycerine to enhance solubility. Toxicity is associated with lactic acidosis and an elevated osmolal gap. 2-Butoxyethanol (MW 118 Da) is found in a number of resins, varnishes, and glass- and leather-cleaning solutions. Diethylene glycol (MW 106 Da) produces metabolic acidosis, acute kidney injury, hypertension, and cardiac arrhythmias; fomepizole is recommended to prevent metabolism by ALDH. Toxicity has been associated with metabolic acidosis, hepatic injury, and respiratory distress. Hemodialysis is effective in removing these alcohols and may be indicated in severe intoxications.
- F. **Lithium carbonate (MW 7 Da).** Most intoxications result from chronic accumulation, renal failure, diuretic use and dehydration, and interactions with angiotensin-converting enzyme (ACE) inhibitors and nonsteroidal anti-inflammatory drugs (NSAIDs). Mild (serum Li 1.5–2.5 mmol/L) and moderate (serum Li 2.5–3.5 mmol/L) lithium toxicity are characterized by neuromuscular irritability, nausea, and diarrhea. Severe toxicity (serum Li >3.5 mmol/L) can result in seizures, stupor, and permanent neurologic deficit. Initially, diuretics should be stopped and prompt rehydration initiated. Sodium polystyrene sulfonate may also facilitate Li elimination (Ghannoum, 2010). As lithium is 0% protein-bound with a V_D of 0.8 L/kg, it is removed very well by dialysis. Hemodialysis should be considered when (a) serum Li >3.5 mmol/L, (b) serum Li >2.5 mmol/L in patients with appreciable symptoms or in patients with renal insufficiency, or (c) when serum Li is between 2.5 and 3.5 mmol/L in asymptomatic patients but when levels are expected to rise (e.g., following recent massive ingestion) or are not expected to fall below 0.8 mmol/L in the next 36 hours, as predicted from a log/linear concentration versus time plot. As serum lithium may rebound

following dialysis owing to a shift from the intracellular compartment, dialysis should be performed using a high-clearance dialyzer for 8 to 12 hours. Repeated dialysis sessions may be necessary until serum Li levels remain below 1.0 mmol/L for 6 to 8 hours after dialysis. Prolonged continuous hemodiafiltration may reduce the rebound of lithium levels posttreatment (Leblanc, 1996).

- G. **Mushroom poisoning.** Ingestion of certain poisonous mushrooms is associated initially with severe gastrointestinal symptoms followed by hepatic insufficiency and cardiovascular collapse. The toxins of these mushrooms (α -amanitin and phalloidin, MW for both \sim 900 Da) are removed by hemodialysis and hemoperfusion in vitro, but the efficacy of hemodialysis or hemoperfusion in patients poisoned by mushrooms has been difficult to interpret because of lack of controls; some survival benefit has been alleged. Activated charcoal adsorption of amanitin and administration of silibinin (a flavanoligand from extracts of milk thistle), which prevents amanitin uptake by liver cells, may be of use (Goldfrank, 2006). Early referral to a poison center and liver transplantation unit is recommended. Plasmapheresis is another experimental treatment option.
- H. **Paraquat (MW 257 Da).** Delayed toxicity with pulmonary fibrosis and renal and multiorgan failure can occur following ingestion of more than 10 mL of paraquat concentrate. Survival is dependent on the amount ingested and the plasma levels with respect to time of ingestion (Proudfoot, 1979). Plasma levels of above 3 mg/L (12 μ mol/L) regardless of when they are measured are usually fatal. Initial management includes gastric lavage with administration of activated charcoal or Fuller's earth with cathartic. Hemoperfusion is effective in drug removal and should be considered when the plasma paraquat level is 0.1 mg/L (0.4 μ mol/L) or above. Repeated or continuous hemoperfusion may be needed for several days to maintain plasma levels below 0.1 mg/L as paraquat has a large V_D and a slow intercompartmental transfer rate. Although the evidence that hemoperfusion improves survival is controversial, the procedure should be considered since occasional patients have recovered despite massive ingestion and pulmonary involvement. Survival after treatment with plasmapheresis has been described (Dearaley, 1978). Recent evidence favors the use of salicylates in treatment in order to interrupt NF κ B activity and provide oxygen scavenging (Dinis-Oliveira, 2009), and use of other antioxidants is investigational (Blanco-Ayala, 2014). Most agree that hemodialysis should be used in the first 24 hours after poisoning.
- I. **Phenothiazines and tricyclic antidepressants.** These agents are highly protein-bound and have extremely large volumes of distribution (in the range of 14–21 L/kg). Hence, the total amount of these drugs removed by either hemodialysis or hemoperfusion is small. Treatment of intoxication with these agents is largely supportive, including bicarbonate therapy for widened QRS complex.
- J. **Anticonvulsants**
1. **Phenytoin (MW 252 Da).** Nystagmus and ataxia occur at serum values $>$ 20 and 30 mg/mL (79 and 119 μ mol/L), respectively. Phenytoin is 90% protein-bound (70% in uremic patients) and has a V_D of 0.64 L/kg. Surprisingly, despite phenytoin's high protein binding, which is not saturable even in overdose, it is removed moderately well by hemodialysis or hemoperfusion.

2. **Sodium valproate (MW 166 Da).** Valproate sodium has a small V_D , is metabolized by the liver, and has significant protein binding. In overdose, protein binding becomes saturated, and free valproate can be subjected to extracorporeal removal. High-flux hemodialysis with or without hemoperfusion should be considered when there is coma, severe liver dysfunction, or other organ failure.
 3. **Carbamazepine (MW 236 Da).** Hemoperfusion can be used for severe intoxications. High-flux hemodialysis also has been reported to give good results (Koh, 2006).
- K. **Sedatives and hypnotics.** Older agents have greater toxicity and, fortunately, are less frequently used today. Since morbidity and mortality can be high, extracorporeal methods have been employed in overdose with these older drugs. Newer agents are associated with lower side effects, and supportive therapy is often sufficient to treat overdose.
- L. **Theophylline (MW 180 Da).** Toxic reactions occur when theophylline levels exceed 25 mg/L (140 mcmmol/L) [therapeutic levels being 10–20 mg/L (56–112 mcmmol/L)]. Chronic intoxication may have more pronounced symptoms at a given serum level. Seizures typically occur with levels >40 mg/L (224 mcmmol/L), but may occur at levels as low as 25 mg/L (139 mcmmol/L). Cardiovascular collapse is rare until levels are >50 mg/L (278 mcmmol/L). Theophylline has V_D of 0.5 L/kg, poor intrinsic metabolism, and 56% protein binding, and is well adsorbed by charcoal, enabling efficacious removal by MDAC and hemoperfusion. MDAC should be used in significant poisonings even with intravenous theophylline overdose, although protracted vomiting is often a limiting factor. Propranolol (1–3 mg IV) may be used to treat tachyarrhythmia, and hypokalemia should be corrected. Hemoperfusion or high-efficiency hemodialysis is indicated if vomiting prevents the use of MDAC, or it can be used in addition to MDAC in patients with seizures, hypotension, or arrhythmia. Hemoperfusion/hemodialysis should also be considered in patients with acute intoxication with levels above 100 mg/L (556 mcmmol/L), in chronic toxicity with levels above 60 mg/L (333 mcmmol/L), and in both the elderly and infants under 6 months of age above 40 mg/L (222 mcmmol/L). Combining hemodialysis with hemoperfusion may further enhance clearance and prevent saturation of the hemoperfusion cartridge. Continuous hemoperfusion has also been used with success in severely toxic and hypotensive patients. Treatment should be continued until the plasma level is 25 to 40 mg/L (140–224 mcmmol/L).
- M. **Dabigatran etexilate mesylate (Pradaxa)** is an oral direct thrombin inhibitor for prophylaxis of thromboembolism in patients with nonvalvular atrial fibrillation. Since its US approval in 2010, dabigatran-associated hemorrhages have been reported, and reversal of its activity has been challenging, given that vitamin K, fresh-frozen plasma, or cryoprecipitate used to reverse warfarin-associated coagulopathies are ineffective. Recent publications have confirmed that dialysis removes the anticoagulant; one in a patient with an intracranial bleed (Chang, 2013) and the other in a series of dialysis patients administered dabigatran at two dose levels and achieving between 49% and 59% of total dabigatran removal with 4 hours hemodialysis (Khadzhynov, 2013). The kinetics seem to follow first-order elimination during dialysis (Liesenfeld, 2013). Continuous venovenous hemodiafiltration may be useful in severe cases (Chiew, 2014).
- N. **“Bath Salts.”** The active compound is cathinone, a natural amphetamine analog from the

plant *Catha edulis* composed of a mixture of 3,4-methylenedioxypropylamphetamine (MPDV) (MW 275 Da) and mephedrone (MW 177 Da). The compound produces sympathetic overactivity, causing cardiac (tachycardia), neurologic (hyperthermia), and psychiatric (agitation) derangements after ingestion, similar to the effects of other stimulants (cocaine, amphetamine, and 3,4-methylenedioxy-*N*-methylamphetamine (MDMA)). These compounds are not detected by routine toxicology screens. Acute kidney injury can result from exposure to these compounds, likely related to rhabdomyolysis and renal arteriolar vasospasm (Adebamiro and Perazella, 2012; Regunath, 2012). Multiorgan failure and deaths have occurred, but owing to the lack of data about this drug, and since most users have coingestions, management similar to that for amphetamines and MDMA intoxications is applied, including supportive care with renal replacement therapy if indicated (Prosser and Nelson, 2012, Mas-Morey, 2013). Hemodialysis is unlikely to be useful in removing the components, assuming they behave similarly, with a short half-life, to amphetamines and MDMA.

- O. **Metformin (MW 129 Da).** Metformin is a biguanide used as an oral antihyperglycemic agent in the treatment of type II diabetes mellitus. It acts by increasing cellular insulin sensitivity. Especially in patients with chronic kidney disease, but also in acute overdose in patients with normal kidney function, lactic acidosis is a rare adverse effect. The condition, which if severe can be fatal, is termed **metformin-associated lactic acidosis (MALA)**. Metformin is absorbed from the gut relatively rapidly and is not metabolized. Ninety percent of the drug is eliminated by glomerular filtration and tubular secretion with a serum half-life between 1.5 and 5 hours. Surreptitious use of metformin may be uncovered in the investigation of lactic acidosis in a normoglycemic or hypoglycemic comatose patient. MALA is defined as a venous serum lactate level >5 mmol/L with serum bicarbonate <22 mmol/L. The mainstay of therapy is supportive, including bicarbonate administration, hemodialysis for correction of acidosis and removal of lactate and metformin. In the study of Peters, 2008, mortality was 30%, and especially in those in shock and with a high number of comorbidities, suggesting that hypoperfusion and not metformin was the cause of the acidosis. The dialyzer extraction ratios obtained for metformin (60%) suggest that it may be removable by extracorporeal treatments (Nguyen and Concepcion, 2011), although its relatively large V_D (3 L/kg) may limit the effectiveness of extracorporeal treatments. Nevertheless, because hemodialysis may rapidly correct the associated metabolic acidosis, it is recommended in severe metformin poisoning.
- P. **Thallium.** Thallium is a highly toxic metal originally used for the treatment of ringworm infestation, and then as a rodenticide, but because of toxicity it is now relegated to industrial use. It is an agent used in homicide, but exposure can occur from contamination of herbal products and drugs of abuse. The potentially fatal oral dose is as low as 6 mg/kg. Thallium mimics potassium, as these two elements are similar in ionic size. Thallium accumulates in nervous tissue, muscle and liver, hair, skin, and nails. Thallium inhibits critical metabolic enzymes such as pyruvate kinase and succinate dehydrogenase. The usual findings of thallium poisoning are alopecia and painful ascending peripheral neuropathy, abdominal pain, vomiting, diarrhea, constipation, autonomic instability, and cranial nerve

involvement with the most severe poisoning exhibiting altered mental status, coma, loss of airway-protection, respiratory paralysis, and cardiac arrest. (Hoffman, 2003). Urine is used (although blood testing is available) as a screening test with a normal thallium concentration of less than 5 mcg/L. Treatment consists of removal from exposure, supportive care, and enhanced elimination; MDAC and Prussian blue enhance elimination via the gastrointestinal tract. Hourly thallium removal by hemodialysis and charcoal hemoperfusion appears superior to removal by normal kidney function and comparable to stool elimination via Prussian blue. There is agreement that modern dialyzers would enhance thallium removal compared with older techniques; however, owing to its large V_D , once distribution of thallium throughout the body is complete, even modern techniques are not likely to remove a significant proportion of the total body burden. If dialysis can be instituted early after ingestion, removal of 1% to 3% of total body stores in a 6-hour treatment has been reported, and thallium might thus qualify as being slightly dialyzable. It is recommended that if thallium exposure is highly suspected on the basis of history or clinical features, dialysis be performed (Ghannoum, 2012).

Other drugs. Management of poisoning due to other agents is beyond the scope of this handbook. The reader is referred to Shannon, 2007, and to Tables 20.8 and 20.9.

TABLE

20.8

Drugs and Chemicals Removed with Hemodialysis

Antimicrobials/Anticancer

Cefaclor
Cefadroxil
Cefamandole
Cefazolin
Cefixime
Cefmenoxime
Cefmetazole
(Cefonicid)
(Cefoperazone)
Ceforamide
(Cefotaxime)
Cefotetan
Cefotiam
Cefoxitin
Cefpirome
Cefroxadine
Cefsulodin
Ceftazidime
(Ceftriaxone)
Cefuroxime

Cephacetrile
Cephalexin
Cephalothin
(Cephapirin)
Cephradine
Moxalactam
Amikacin
Dibekacin
Daptomycin
Fosfomycin
Gentamicin
Kanamycin
Neomycin
Netilmicin
Sisomicin
Streptomycin
Tobramycin
Bacitracin
Colistin
Amoxicillin
Ampicillin
Azlocillin
Carbenicillin
Clavulinic acid
(Cloxacillin)
(Dicloxacillin)
(Floxacillin)
Mecillinam
(Mezlocillin)
(Methicillin)
(Nafcillin)
Penicillin
Piperacillin
Temocillin
Ticarcillin
(Clindamycin)
(Erythromycin)
(Azithromycin)
(Clarithromycin)
Linezolid
Metronidazole
Nitrofurantoin
Ornidazole

Sulfisoxazole
Sulfonamides
Tetracycline
(Doxycycline)
(Minocycline)
Tinidazole
Trimethoprim
Aztreonam
Cilastatin
(Dapsone)
Doripenem
Imipenem
(Chloramphenicol)
(Amphotericin)
Ciprofloxacin
(Enoxacin)
Fluroxacin
(Norfloxacin)
Ofloxacin
Isoniazid
(Vancomycin)
Capreomycin
PAS
Pyrizinamide
(Rifampin)
(Cycloserine)
Ethambutol
5-Fluorocytosine
Acyclovir
(Amantadine)
Didanosine
Foscarnet
Ganciclovir
(Ribavirin)
Vidarabine
Zidovudine
(Pentamidine)
(Praziquantel)
(Fluconazole)
(Itraconazole)
(Ketoconazole)
(Miconazole)
(Chloroquine)

(Quinine)
(Azathioprine)
Bredinin
Busulphan
Cyclophosphamide
5-Fluorouracil
(Methotrexate)
Barbiturates
Amobarbital
Aprobarbital
Barbital
Butobarbital
Cyclobarbital
Pentobarbital
Phenobarbital
Quinalbital
(Secobarbital)

Nonbarbiturate Hypnotics, Sedatives, Tranquilizers, Anticonvulsants

Carbamazepine
Baclofen
Betaxolol
(Bretylum)
Clonidine
(Calcium channel blockers)
Captopril
(Diazoxide)
Carbromal
Chloral hydrate
(Chlordiazepoxide)
(Diazepam)
(Diphenylhydantoin)
(Diphenylhydramine)
Ethiamate
Ethchlorvynol
Ethosuximide
Gallamine
Glutethimide
(Heroin)
Meprobamate
(Methaqualone)
Methsuximide
Methyprylon

Paraldehyde
Primidone
Topiramate
Valproic acid

Cardiovascular Agents

Acebutolol
(Amiodarone)
Amrinone
Atenolol
(Digoxin)
Enalapril
Fosinopril
Lisinopril
Quinapril
Ramipril
(Encainide)
(Flecainide)
(Lidocaine)
Metoprolol
Methyldopa
Mexiletine
(Ouabain)
N-acetylprocainamide
Nadolol
(Pindolol)
Practolol
Procainamide
Propranolol
(Quinidine)
(Timolol)
Sotalol
Tocainide

Alcohols

Ethanol
Ethylene glycol
Isopropanol
Methanol

Analgesics, Antirheumatics

Acetaminophen
Acetophenetidin
Acetylsalicylic acid

Colchicine
Methylsalicylate
(D-Propoxyphene)
Salicylic acid

Antidepressants

(Amitriptyline)
Amphetamines
(Imipramine)
Isocarboxazid
MAO inhibitors
Moclobemide
(Pargyline)
(Phenelzine)
Tranlycypromine
(Tricyclics)

Solvents, Gases

Acetone
Camphor
Carbon monoxide
(Carbon tetrachloride)
(Eucalyptus oil)
Thiols
Toluene
Trichloroethylene

Plants, Animals, Herbicides, Insecticides

Alkyl phosphate
Amanitin
Averrhoa carambola/star fruit/oxalate
Demeton sulfoxide
Dimethoate
Diquat
Endosulfan
Glufosinate
(Roundup/glyphosate)
Methylmercury complex
(Organophosphates)
Paraquat
Snake bite
Sodium chlorate
Potassium chlorate
Trees (hemlock, yew)

Miscellaneous

Acipimox
Allopurinol
Aminophylline
Aniline
Borates
Boric acid
(Chlorpropamide)
Chromic acid
(Cimetidine)
Dinitro-o-cresol
Folic acid
Mannitol
Metformin (drug and lactate removal)
Methylprednisolone
4-Methylpyrazole
Sodium citrate
Theophylline
Thiocyanate
Ranitidine

Metals, Inorganics

(Aluminum)* High-flux HD with chelation may be superior to HP
Arsenic
Barium
Bromide
(Copper)*
(Iron)*
(Lead)*
Lithium
(Magnesium)
(Mercury)*
Potassium
(Potassium dichromate)*
Phosphate
Sodium
Strontium
Thallium
(Tin)
(Zinc)

() Implies poor removal.

*Removed with chelating agent.

Barbiturates

Amobarbital
Butobarbital
Hexobarbital
Pentobarbital
Phenobarbital
Quinalbital
Secobarbital
Thiopental
Vinalbital

Nonbarbiturate Hypnotics, Sedatives, and Tranquilizers

Carbamazepine
Carbromal
Chloral hydrate
Chlorpromazine
(Diazepam)
Diphenhydramine
Ethchlorvynol
Glutethimide
Meprobamate
Methaqualone
Methsuximide
Methyprylon
Phenytoin
Promazine
Promethazine
Valproic acid

Analgesics, Antirheumatic

Acetaminophen
Acetylsalicylic acid
Colchicine
D-propoxyphyene
Methylsalicylate
Phenylbutazone
Salicylic acid

Antimicrobials/Anticancer

(Adriamycin)
Ampicillin
Carmustine
Chloramphenicol
Chloroquine
Clindamycin
Dapsone
Doxorubicin
Gentamicin
Ifosfamide
Isoniazid
(Methotrexate)
Pentamidine
Thiabendazole
(5-Fluorouracil)
Vancomycin

Antidepressants

(Amitriptyline)
(Imipramine)
(Tricyclics)

Plant and Animal Toxins, Herbicides, Insecticides

Amanitin
Chlordane
Demeton sulfoxide
Dimethoate
Diquat
Endosulfan
Glufosinate
Methylparathion
Nitrosthigmine
(Organophosphates)
Phalloidin
Polychlorinated biphenyls
Paraquat
Parathion

Cardiovascular

Atenolol
Cibenzoline succinate
Clonidine
Digoxin
(Diltiazem)

(Disopyramide)
Flecainide
Metoprolol
N-acetylprocainamide
Procainamide
Quinidine

Miscellaneous

Aminophylline
Cimetidine
(Fluoroacetamide)
(Phencyclidine)
Phenols
(Podophyllin)
Theophylline

Solvents, Gases

Carbon tetrachloride
Ethylene oxide
Trichloroethane
Xylene

Metals

(Aluminum)*
(Iron)*

() Implies poor removal.

*Removed with chelating agent.

References and Suggested Readings

- Adebamiro A, Perazella MA. Recurrent acute kidney injury following bath salts intoxication. *Am J Kidney Dis*. 2012;59:273–275.
- Barceloux DG, et al. American Academy of Clinical Toxicology practice guidelines on the treatment of ethylene glycol poisoning. Ad Hoc Committee. *J Toxicol Clin Toxicol*. 1999;37:537.
- Barceloux DG, et al. American Academy of Clinical Toxicology practice guidelines on the treatment of methanol poisoning. *J Toxicol Clin Toxicol*. 2002;40:415.
- Blanco-Ayala T, Andérica-Romero AC, Pedraza-Chaverri J. New insights into antioxidant strategies against paraquat toxicity. *Free Radic Res*. 2014;48:623–640.
- Bronstein AC, et al. 2011 Annual report of the American Association of Poison Control Centers' National Poison Data System (NPDS): 29th Annual Report. *Clin Toxicol (Phila)*. 2012;50:911–1164.
- Chang DN, Dager WE, Chin AI. Removal of dabigatran by hemodialysis. *Am J Kidney Dis*. 2013;61:487–489.

- Chiew AL, Khamoudes D, Chan BS. Use of continuous veno-venous haemodiafiltration therapy in dabigatran overdose. *Clin Toxicol (Phila)*. 2014;52:283–287.
- Chow MT, et al. Hemodialysis-induced hypophosphatemia in a normophosphatemic patient dialyzed for ethylene glycol poisoning: treatment with phosphorus-enriched hemodialysis. *Artif Organs*. 1998;22:905.
- Dearaley DP, et al. Plasmapheresis for paraquat poisoning. *Lancet*. 1978;1:162.
- Dinis-Oliveira RJ, et al. An effective antidote for paraquat poisonings: the treatment with lysine acetylsalicylate. *Toxicology*. 2009 31;255:187–193.
- Doorenbos CJ, et al. Use of urea containing dialysate to avoid disequilibrium syndrome, enabling intensive dialysis treatment of a diabetic patient with renal failure and severe glucophage induced lactic acidosis. *Nephrol Dial Transplant*. 2001;16:1303.
- Done AK, Temple AR. Treatment of salicylate poisoning. *Modern Treat*. 1971;8:528.
- Fleig SV, et al. Digoxin intoxication in acute or chronic kidney failure: elimination of digoxin bound to Fab-fragments (Digifab) with high cut-off filter dialysis. [Abstract]. *J Am Soc Nephrol*. 2011;22:317A.
- Ghannoum M, et al. Successful treatment of lithium toxicity with sodium polystyrene sulfonate: a retrospective cohort study. *Clin Toxicol (Phila)*. 2010;48:34–41.
- Ghannoum M, et al; Extracorporeal Treatments in Poisoning Workgroup. Extracorporeal treatment for thallium poisoning: recommendations from the EXTRIP Workgroup. *Clin J Am Soc Nephrol*. 2012;7:1682–90.
- Ghannoum M, et al. Trends in toxic alcohol exposures in the United States from 2000 to 2013: a focus on the use of antidotes and extracorporeal treatments. *Semin Dial*. 2014;27:395–401.
- Ghannoum M, et al. Hemoperfusion for the treatment of poisoning: technology, determinants of poison clearance, and application in clinical practice. *Semin Dial*. 2014;27:350–361.
- Goldfrank LR. Mushrooms. In: Nelson LS, et al., eds. *Goldfrank's Toxicologic Emergencies*. New York, NY: McGraw Hill; 2011:1522.
- Hoffman RS. Thallium toxicity and the role of Prussian Blue in therapy. *Toxicol Rev*. 2003;22:29–40.
- Hussain SA, et al. Phosphate enriched hemodialysis during pregnancy: two case series. *Hemodial Int*. 2005;9:147.
- Jacobsen G, et al. Antidotes for methanol and ethylene glycol poisoning. *J Toxicol Clin Toxicol*. 1997;35:127.
- Khadzhynov D, et al. Effective elimination of dabigatran by haemodialysis: A phase I single-centre study in patients with end-stage renal disease. *Thromb Haemost*. 2013;109:596–605.
- Koh KH, et al. High-flux haemodialysis treatment as treatment for carbamazepine intoxication. *Med J Malaysia*. 2006;61:109.
- Ku Y, et al. Clinical pilot study on high-dose intra-arterial chemotherapy with direct hemoperfusion under hepatic venous isolation in patients with advanced hepatocellular carcinoma. *Surgery*. 1995;117:510.
- Kulig K. Initial management of ingestions of toxic substances. *N Engl J Med*. 1992;326:1677.
- Lavergne V, et al. The EXTRIP (EXtracorporeal TReatments In Poisoning) workgroup: guideline methodology. *Clin Toxicol (Phila)*. 2012;50:403–413.
- Leblanc M, et al. Lithium poisoning treated by high-performance arteriovenous and venovenous hemodiafiltration. *Am J Kidney Dis*. 1996;27:365.

- Liesenfeld KH, et al. Pharmacometric characterization of dabigatran hemodialysis. *Clin Pharmacokinet*. 2013;52:453–462.
- Martiny S, et al. Treatment of severe digoxin intoxication with digoxin-specific antibody fragments: a clinical review. *Crit Care Med*. 1987;16:629.
- Mas-Morey P, et al. Clinical toxicology and management of intoxications with synthetic cathinones (“Bath Salts”). *J Pharm Pract*. 2013;26:353–357.
- Mowry J, et al. 2012 Annual Report of the American Association of Poison Control Centers’ National Poison Data System (NPDS): 30th Annual Report. *Clin Toxicol*. 2013;51:949–1229.
- Nguyen HL, Concepcion L. Metformin intoxication requiring dialysis. *Hemodial Int*. 2011;15(suppl 1):S68–71.
- Palmer BF. Effectiveness of hemodialysis in the extracorporeal therapy of phenobarbital overdose. *Am J Kidney Dis*. 2000;36:640–643.
- Proudfoot AT, et al. Paraquat poisoning: significance of plasma paraquat concentrations. *Lancet*. 1979;2:330.
- Peters N, et al. Metformin-associated lactic acidosis in an intensive care unit. *Crit Care*. 2008;12:R149.
- Prosser JM, Nelson LS. The toxicology of bath salts: a review of synthetic cathinones. *J Med Toxicol*. 2012;8:33–42.
- Regunath H, et al. Bath salt intoxication causing acute kidney injury requiring hemodialysis. *Hemodial Int*. 2012;16:S47–9.
- Sam R, et al. Using disodium monohydrogen phosphate to prepare a phosphate-enriched hemodialysate. *Hemodial Int*. 2013;17:667–668.
- Samtleben W, et al. Plasma exchange and hemoperfusion. In: Jacobs C, et al., eds. *Replacement of renal function by dialysis*. Dordrecht: Kluwer Academic Publishers; 1996:1260.
- Shalkham AS, et al. The availability and use of charcoal hemoperfusion in the treatment of poisoned patients. *Am J Kidney Dis*. 2006;48:239–241.
- Shannon MW, Borron SW, Burns MJ, eds. *Haddad and Winchester’s Clinical Management of Poisoning and Drug Overdose*. 4th ed. Philadelphia, PA: Saunders Elsevier; 2007.
- Ujhelyi MR, et al. Disposition of digoxin immune Fab in patients with kidney failure. *Clin Pharmacol Ther*. 1993;54:388.
- Wadgymar A, et al. Treatment of acute methanol intoxication with hemodialysis. *Am J Kidney Dis*. 1998;31:897.
- Wanek MR, et al. Safe use of hemodialysis for dabigatran removal before cardiac surgery. *Ann Pharmacother*. 2012;46:e21.
- Yates C, Galvao T, Sowinski KM, et al. Extracorporeal Treatment for Tricyclic Antidepressant Poisoning: Recommendations from the EXTRIP Workgroup. *Semin Dial*. 2014;27:381–389.
- Yip L, et al. Concepts and controversies in salicylate toxicity. *Emerg Med Clin North Am*. 1994;12:351.
- Zdunek M, et al. Plasma exchange for the removal of digoxin-specific antibody fragments in renal failure: timing is important for maximizing clearance. *Am J Kidney Dis*. 2000;36:177.

PART III

PERITONEAL DIALYSIS

Peritoneal dialysis is the method of renal replacement therapy used by about 200,000 patients worldwide. Since the introduction of continuous ambulatory peritoneal dialysis (CAPD) almost four decades ago and more recently of compact “easy-to-use” hydraulic cyclers for automated peritoneal dialysis (APD), the popularity of peritoneal dialysis has increased greatly. This is because peritoneal dialysis is simple, convenient, and relatively low cost, and because it can be done in the home.

I. WHAT IS PERITONEAL DIALYSIS? In essence, peritoneal dialysis involves the transport of solutes and water across a “membrane” that separates two fluid-containing compartments: (a) the blood in the peritoneal capillaries, which in renal failure contains an excess of urea, creatinine, potassium, and other waste products, and (b) the dialysis solution in the peritoneal cavity, which typically contains sodium, chloride, and lactate or bicarbonate and which is rendered hyperosmolar by the inclusion of a high concentration of glucose. During the course of a peritoneal dialysis dwell, three transport processes occur simultaneously: diffusion, ultrafiltration, and absorption. The amount of dialysis achieved and the extent of fluid removal depend on the volume of dialysis solution infused (called the dwell volume), how often this dialysis solution is exchanged, and the concentration of crystalloid osmotic or colloid oncotic agent present.

II. FUNCTIONAL ANATOMY

A. Anatomy of the peritoneal cavity. The peritoneum is the serosal membrane that lines the peritoneal cavity (Fig. 21.1). It has a surface area that is similar to body surface area, and so typically ranges from 1 to 2 m² in an adult. The peritoneum is divided into two portions:

1. The visceral peritoneum, which lines the gut and other viscera
2. The parietal peritoneum, which lines the walls of the abdominal cavity

The visceral peritoneum accounts for about 80% of the total peritoneal surface area. It receives its blood supply from the superior mesenteric artery, and venous drainage is via the portal system. The parietal peritoneum, which may be more important in peritoneal dialysis, receives blood from the lumbar, intercostal, and epigastric arteries and drains into the inferior vena cava. Total peritoneal blood flow cannot be directly measured, but has been estimated to range from 50 to 100 mL/min. The main lymphatic drainage of the peritoneum and of the peritoneal cavity is via

stomata in the diaphragmatic peritoneum, which ultimately drain via large collecting ducts into the right lymphatic duct. Additional drainage occurs via lymphatics present in both the visceral and the parietal peritoneum.

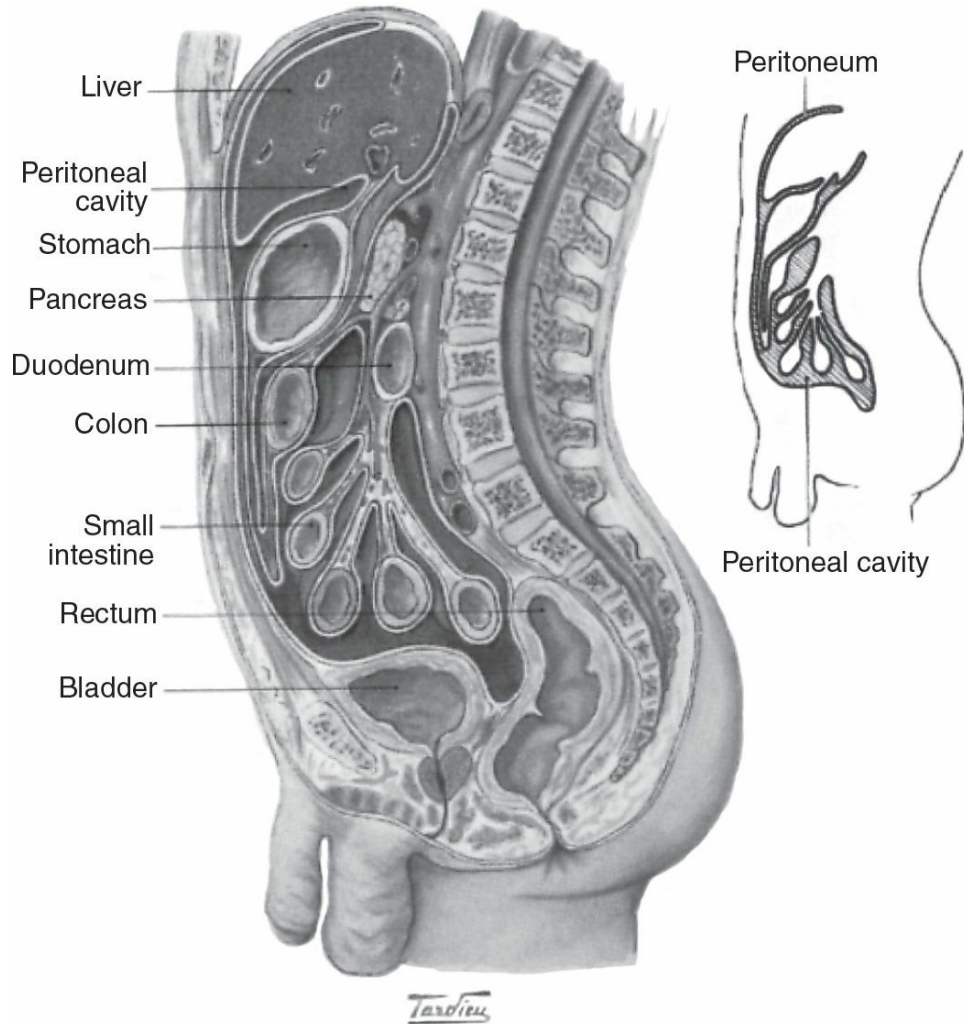

FIGURE 21.1 Simplified anatomy of the peritoneal cavity showing the visceral and parietal peritoneal membrane. (Adapted from Khanna R, et al., eds. *The Essentials of Peritoneal Dialysis*. Dordrecht: Kluwer; 1993.)

- B. Peritoneal membrane histology.** The peritoneal membrane is lined by a monolayer of mesothelial cells equipped with microvillae that produce a thin film of lubricating fluid. Underlying the mesothelium is the interstitium, which comprises a gel-like matrix containing collagenous and other fibers, the peritoneal capillaries, and some lymphatics.
- C. Models of peritoneal transport.** There are six regions of resistance to moving solute and water across the peritoneum from capillary blood to peritoneal fluid: (a) the stagnant capillary fluid film overlying the endothelium of the peritoneal capillaries, (b) the capillary endothelium itself, (c) the endothelial basement membrane, (d) the interstitium, (e) the mesothelium, and (f) the stagnant fluid film that overlies the mesothelium.

Of these, the two stagnant fluid films and the mesothelial cell are thought to offer only trivial resistance to transport. Two concepts of peritoneal transport are popular; they are complementary and not mutually exclusive, and they emphasize the importance of the peritoneal vasculature and the interstitium. They are the three-pore model and the

distributed model.

1. **The three-pore model.** This model, which has been well validated by clinical observations, holds that the peritoneal capillary is the critical barrier to peritoneal transport and that solute and water movement across the peritoneal capillary is dependent on the relative abundance of pores of three different sizes (Fig. 21.2).
 - a. **Large pores** with a radius of 20–40 nm, are thought to be large clefts in the endothelium. Macromolecules, such as protein are transported by convection through these pores.
 - b. **Small pores** with a radius of 4–6 nm, likely represent smaller clefts between endothelial cells. The density of these small pores affects transport of small solutes such as urea, creatinine, sodium, and potassium, in association with water.

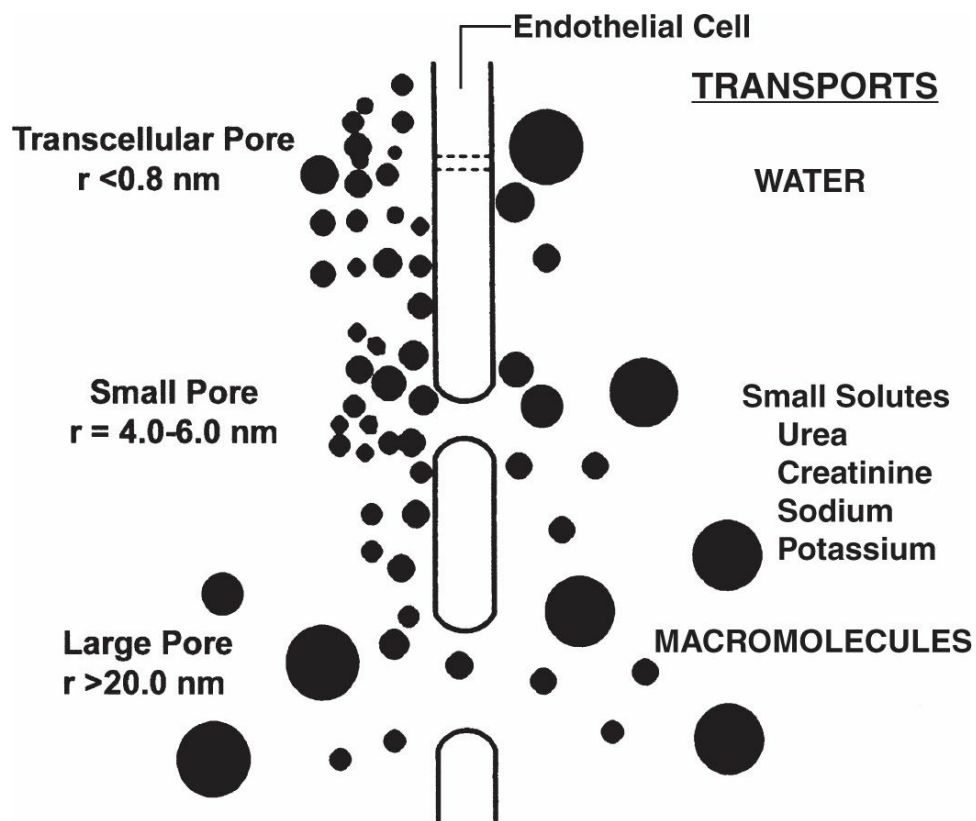

FIGURE 21.2 Diagrammatic representation of the three-pore model of peritoneal transport. (Adapted from Flessner MF. Peritoneal transport physiology: insights from basic research. *J Am Soc Nephrol.* 1991;2:122.)

- c. **Ultrapore**s with a radius of < 0.8 nm, are thought to be aquaporins in the endothelial cell membrane. The ultrapores are responsible for the transport of water only and account for “sieving” by the peritoneal membrane (see what follows).
2. **Distributed model and effective peritoneal surface area.** The distributed model emphasizes the importance of the distribution of capillaries in the peritoneal membrane and of the distance water and solutes have to travel from the capillaries across the interstitium to the mesothelium (Fig. 21.3). Transport is dependent on the surface area of the peritoneal capillaries rather than on the total peritoneal surface area. Furthermore, the distance of each capillary from the mesothelium determines its relative contribution. The cumulative contribution of all of the peritoneal capillaries determines the effective

surface area and the resistance properties of the membrane. From the distributed model, the concept of “effective peritoneal surface area” has arisen. This is the area of the peritoneal surface that is sufficiently close to the peritoneal capillaries to play a role in transport. Therefore, two patients with the same peritoneal surface area may have markedly different peritoneal vascularity and very different effective peritoneal surface areas. In a given patient, effective peritoneal surface area may vary in different circumstances, increasing, for example, in peritonitis when inflammation increases vascularity. The degree of vascularity of the peritoneum is more important than its surface area in determining the transport characteristics of an individual patient.

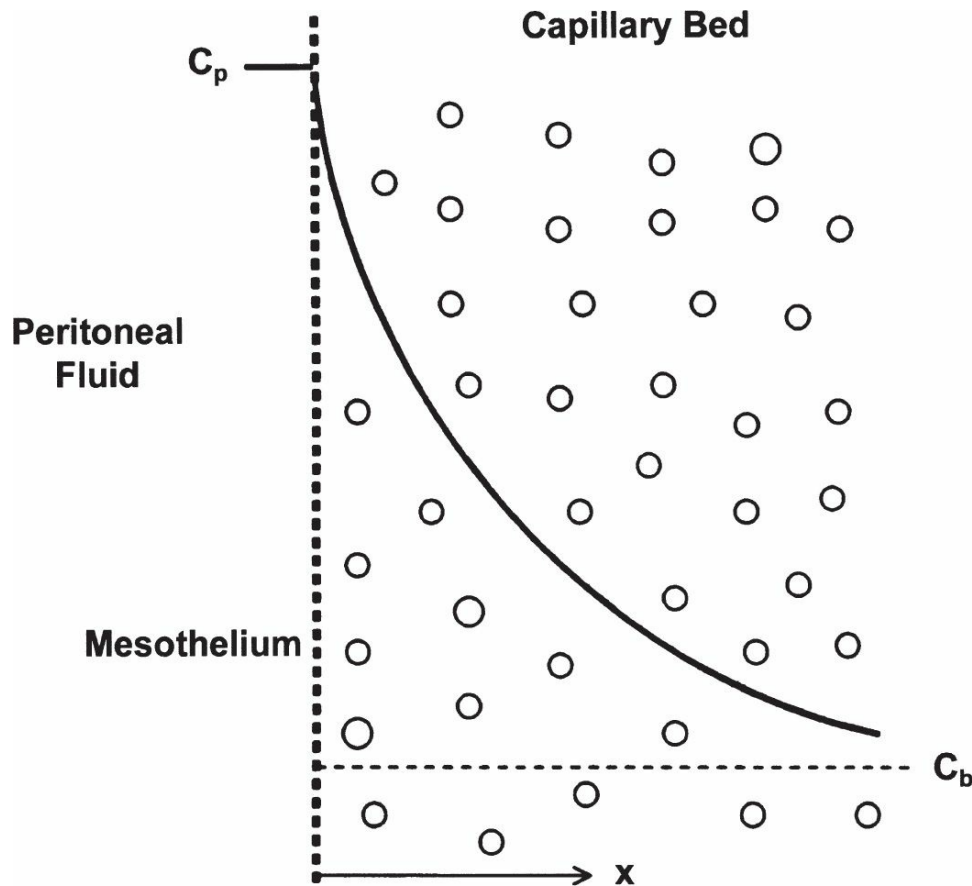

FIGURE 21.3 Distributed model concept showing distribution of peritoneal capillaries in the interstitium and their distances from the mesothelium, represented by the dotted, vertical line. C_p , the solid, curved line, represents the efficiency of transport from a given capillary to the peritoneal space, increasing for capillaries located closest to the mesothelial boundary. (Adapted from Flessner MF. Peritoneal transport physiology: insights from basic research. *J Am Soc Nephrol.* 1991;2:122.)

III. PHYSIOLOGY OF PERITONEAL TRANSPORT. Peritoneal transport comprises three processes that take place simultaneously: (a) diffusion, (b) ultrafiltration, and (c) fluid absorption.

A. Diffusion. Uremic solutes and potassium diffuse from peritoneal capillary blood into the peritoneal fluid, whereas glucose and lactate or bicarbonate present in the dialysate diffuse in the opposite direction. Peritoneal diffusion depends on the following factors:

- 1. The concentration gradient.** For a substance such as urea, this is maximal at the start of a peritoneal dialysis dwell, when the concentration in the dialysis solution is zero. With ongoing diffusion during the course of the dwell, this gradient gradually decreases. The

diminishing gradient can be counteracted partially by the performance of more frequent exchanges, as is typically done in APD, or by increasing dwell volumes, which allows the gradient to remain greater for a longer time.

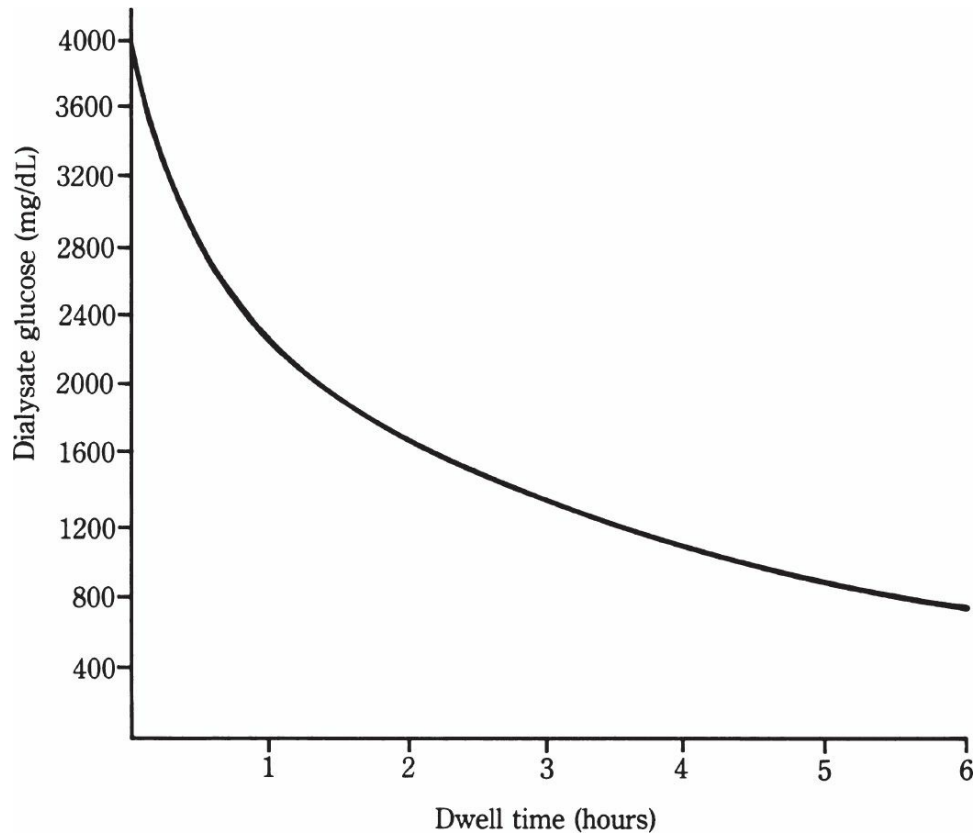

FIGURE 21.4 Dialysate glucose level after instillation of a 4.25% dextrose (3.86% glucose) exchange into the peritoneal cavity. The initial level is close to 3,860 mg/dL (214 mM).

2. **Effective peritoneal surface area.** This can be increased by using larger fill volumes, which recruit more peritoneal membrane, but this effect is limited in most individuals once volumes reach 2.5–3 L.
3. **Intrinsic peritoneal membrane resistance.** This parameter is not well characterized but may reflect differences in the number of pores per unit surface area of capillary available for peritoneal transport and the distance between these capillaries and the mesothelium.
4. **Molecular weight of the solute.** Substances with lower molecular weight, such as urea (MW 60), are more rapidly transported by diffusion than those with higher molecular weights, such as creatinine (MW 113) or uric acid (MW 168).
5. **Mass transfer area coefficient.** The combined effects of factors 2–4 are sometimes measured by an index called the mass transfer area coefficient (MTAC), which is analogous to the K_0A of a hemodialysis membrane. For a given solute, the MTAC is equivalent to the diffusive clearance of that solute per unit time in a theoretical situation in which dialysate flow is infinitely high so that the solute gradient is always maximal. Typical MTAC values for urea and creatinine are 17 and 10 mL/min, respectively. The MTAC is mainly a research tool and is not used much in clinical practice.
6. **Peritoneal blood flow.** Diffusion generally does not depend on peritoneal blood flow, which, at 50–100 mL/min, is already more than adequate relative to MTAC values for

even the smallest solutes. Instead, in contrast to the situation in hemodialysis, diffusion in peritoneal dialysis is dependent primarily on the dialysate flow rate. Vasoactive agents do influence peritoneal transport, but this is not related to their ability to increase peritoneal blood flow; rather, it is due to recruitment of larger numbers of peritoneal capillaries, increasing the effective peritoneal surface area. The same effect is seen in peritonitis, where inflammation increases peritoneal vascularity with a consequent increase in diffusion.

- B. **Ultrafiltration.** This occurs as a consequence of the osmotic gradient between the dialysis solution and the peritoneal capillary blood; it is due to the presence of high concentrations of glucose (or other osmotic agent) in the dialysis solution and depends on the following:
1. **Concentration gradient for the osmotic agent (e.g., glucose).** This typically is maximal at the start of a peritoneal dialysis dwell, and decreases with time due to dilution of dialysate glucose by ultrafiltrate from the plasma, and to diffusion of glucose from the dialysis solution into the blood (Fig. 21.4). The dialysate-to-plasma osmotic gradient will be smaller in the presence of marked hyperglycemia. The gradient can be maximized by using higher dextrose dialysis solutions or by doing more frequent exchanges, as is done with APD.
 2. **Effective peritoneal surface area** (as described earlier).
 3. **Hydraulic conductance of the peritoneal membrane.** This differs between patients and likely reflects the density of small pores and ultrapores in the peritoneal capillaries, as well as the distribution of capillaries in the interstitium.
 4. **Reflection coefficient for the osmotic agent (e.g., glucose).** This measures how effectively the osmotic agent diffuses out of the dialysis solution into the peritoneal capillaries. The reflection coefficient is between 0 and 1; the lower the value, the faster the osmotic gradient is lost and the less sustained ultrafiltration is. For glucose, the reflection coefficient is remarkably low (approximately 0.03), indicating how imperfect an osmotic agent glucose is. The polyglucose preparation, icodextrin, has a reflection coefficient close to 1.0.
 5. **Hydrostatic pressure gradient.** Normally, the peritoneal capillary pressure (around 20 mm Hg) is higher than the intraperitoneal pressure (around 7 mm Hg), which should favor fluid removal by ultrafiltration. This gradient will be greater in a volume-expanded patient and less in a volume-depleted patient. Rises in intraperitoneal pressure will decrease ultrafiltration, and this may be seen when larger dwell volumes are used or when the patient is seated or standing.
 6. **Oncotic pressure gradient.** Oncotic pressure acts to keep fluid in the blood, and so opposes ultrafiltration. In hypoalbuminemic patients, oncotic pressure is low and ultrafiltration may be greater than usual.
 7. **Sieving.** Sieving occurs when solute moves along with water across a semipermeable membrane by convection, but some of the solute is held back or “sieved.” Sieving therefore renders ultrafiltration a less effective form of solute removal, although water removal may occur unhindered. Sieving coefficients for various solutes differ and depend on molecular weight and charge. Sieving coefficients for the same solute can differ between patients, depending on patient-specific peritoneal membrane

characteristics (e.g., ultrapore density in capillary endothelial cells). About half of total ultrafiltration occurs through ultrapores, and this transports solute-free water. The remaining half of ultrafiltration occurs through small endothelial pores, which are clefts between endothelial cells, and here sieving is likely absent, and the solute concentration of this portion of the ultrafiltrate is similar to that in plasma (La Milia, 2005).

8. **Alternative osmotic agents (icodextrin).** Icodextrin is a large molecule and an oncotic agent with a high reflection coefficient. Ultrafiltration using icodextrin is sustained at a relatively constant level throughout even a long-duration dwell.
- C. **Fluid absorption.** Fluid absorption from the peritoneal space occurs via lymphatics at a relatively constant rate. There is little or no sieving. Fluid absorption via lymphatics reduces the efficiency of both solute and fluid removal by peritoneal dialysis. Only a small proportion of fluid absorption occurs directly into the subdiaphragmatic lymphatics. Fluid is also absorbed via the parietal peritoneum into the tissues of the abdominal wall, from where it is subsequently taken up by local lymphatics and perhaps by peritoneal capillaries. Typical rates of peritoneal fluid absorption are 1.0–2.0 mL/min. The factors that affect the rate of fluid absorption of a peritoneal dwell are as follows:
1. **Intraperitoneal hydrostatic pressure.** High pressures will increase the amount of fluid absorbed. High intraperitoneal hydrostatic pressure can result from increased intraperitoneal volume owing to effective ultrafiltration, or to use of a large infusion volume. Intraperitoneal pressure is higher when sitting than when standing, and it is lowest when supine (Fig. 21.5).

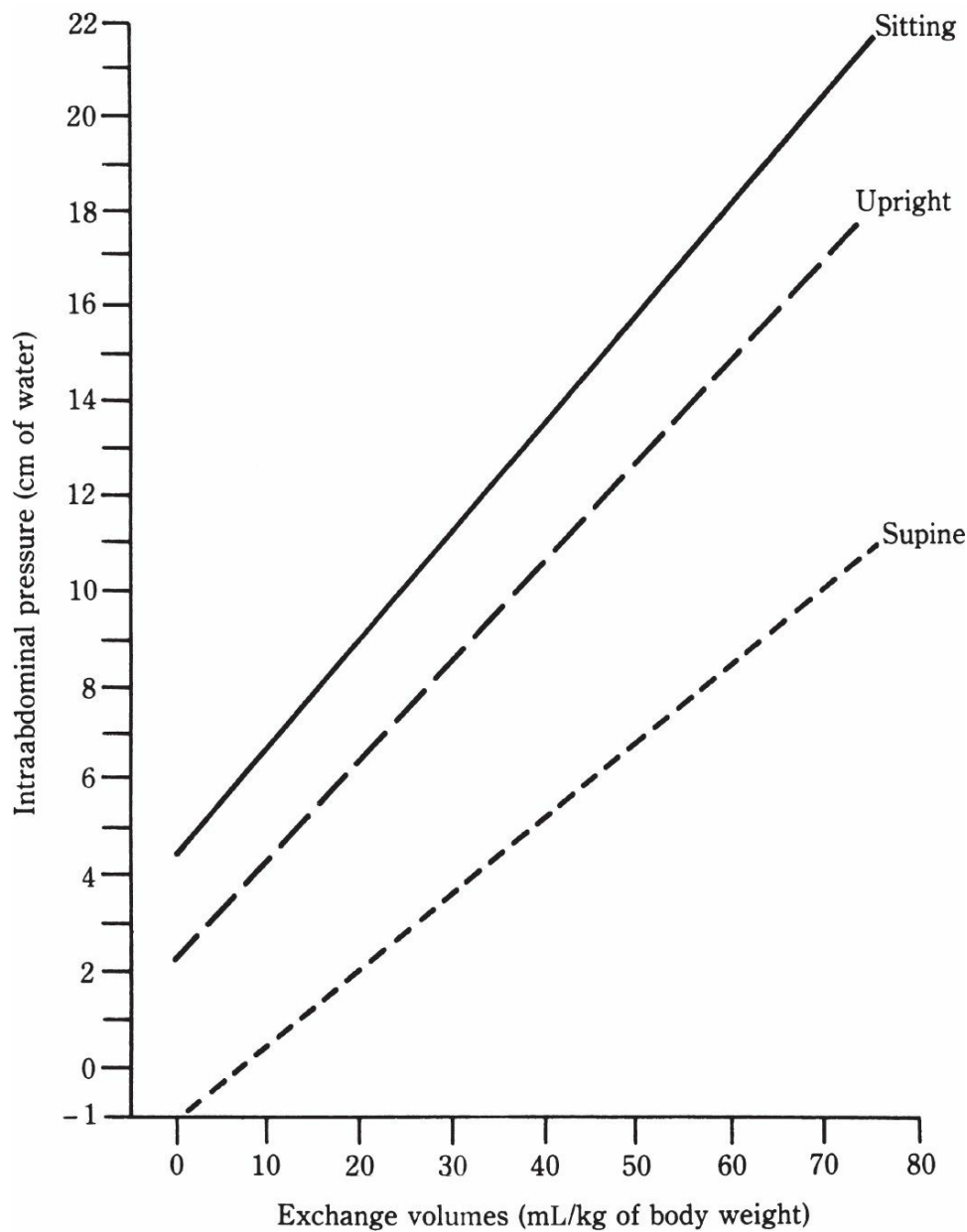

FIGURE 21.5 Intra-abdominal pressure after infusing various volumes of dialysis solution. (Modified from Diaz-Buxo JA. Continuous cycling peritoneal dialysis. In: Nolph KD, ed. *Peritoneal Dialysis*. Hingham, MA: Martinus Nijhoff; 1985.)

2. **Effectiveness of lymphatics.** The effectiveness of lymphatics in absorbing fluid from the peritoneal cavity can differ markedly from person to person for reasons that are not well understood.

IV. CLINICAL ASSESSMENT AND IMPLICATIONS OF PERITONEAL TRANSPORT

- A. **Peritoneal equilibration test (PET).** In clinical practice, indices such as the MTAC and hydraulic conductance of the peritoneal membrane are too complex for routine measurement. Peritoneal transport is assessed using equilibration ratios between dialysate and plasma for urea (D/P urea), creatinine (D/P Cr), and sodium (D/P Na) (Fig. 21.6). Equilibration ratios measure the combined effect of diffusion and ultrafiltration rather than either in isolation. However, they correlate well with MTAC values for the corresponding solutes. They are influenced by the molecular weight of the solute concerned as well as by the patient's peritoneal membrane permeability and effective surface area. Body size tends to

have little relation to equilibration ratios despite its supposed equivalence to peritoneal surface area, suggesting that actual and effective peritoneal surface areas correlate poorly.

Conventionally, equilibration ratios are measured using a standardized PET that involves instillation of a 2.5% 2-L dextrose dwell with dialysate samples taken at 0, 2, and 4 hours and a plasma sample at 2 hours. The PET is also used to measure net fluid removal (volume drained at 4 hours vs. volume instilled) and the ratio of dialysate glucose at 4 hours to dialysate glucose at time zero (D/D_0 G). Patients are classified principally on the basis of their 4-hour D/P Cr into one of four “transporter” categories: high, high-average, low-average, and low transporters (Fig. 21.7). Use of PET results to optimize a peritoneal dialysis prescription is described in Chapter 25.

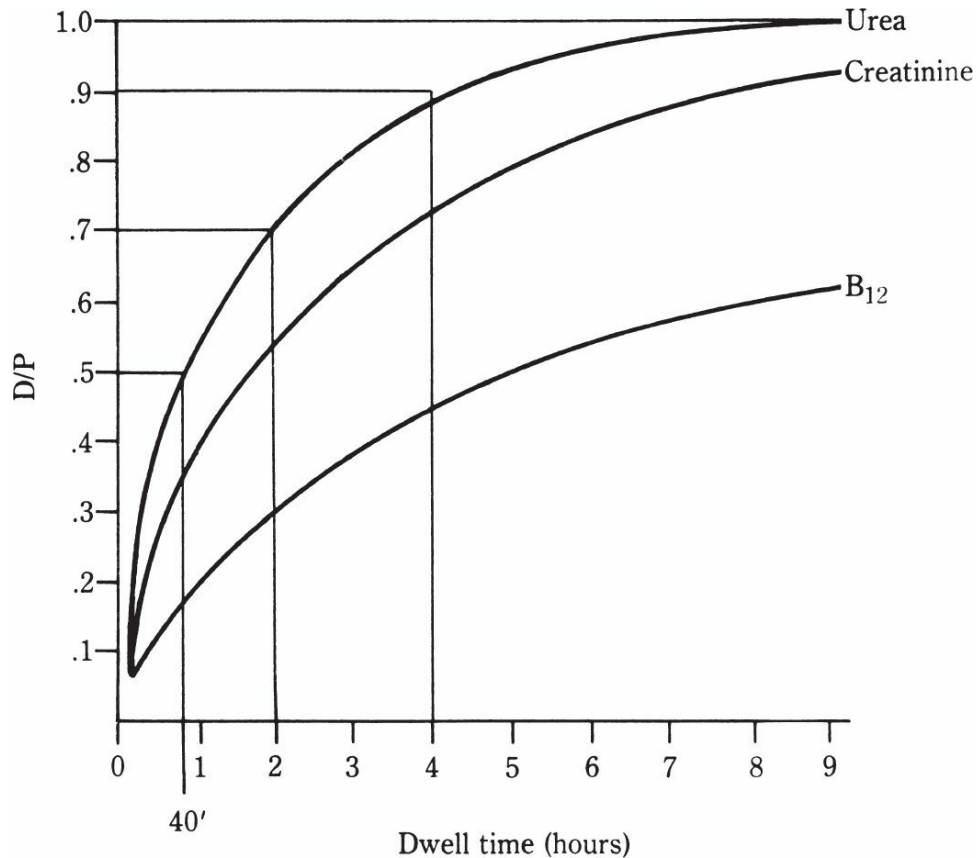

FIGURE 21.6 Rate of entry of urea, creatinine, and vitamin B₁₂ into peritoneal dialysis solution that has been left in the abdomen. Results are expressed as the ratio of the level in dialysate (D) to the level in plasma (P). Typical D/P ratios for urea at time points of 40 min, 2 hr, and 4 hr are indicated.

1. **High transporters** achieve the most rapid and complete equilibration for creatinine and urea, because they have a relatively large effective peritoneal surface area and/or high intrinsic membrane permeability. However, high transporters rapidly lose their osmotic gradient for ultrafiltration because the dialysate glucose diffuses into the blood through the highly permeable membrane. Thus, high transporters have the highest D/P Cr, D/P Ur, and D/P Na values but have low net ultrafiltration and D/D_0 G values. They also have higher dialysate protein losses and so tend to have lower serum albumin values.

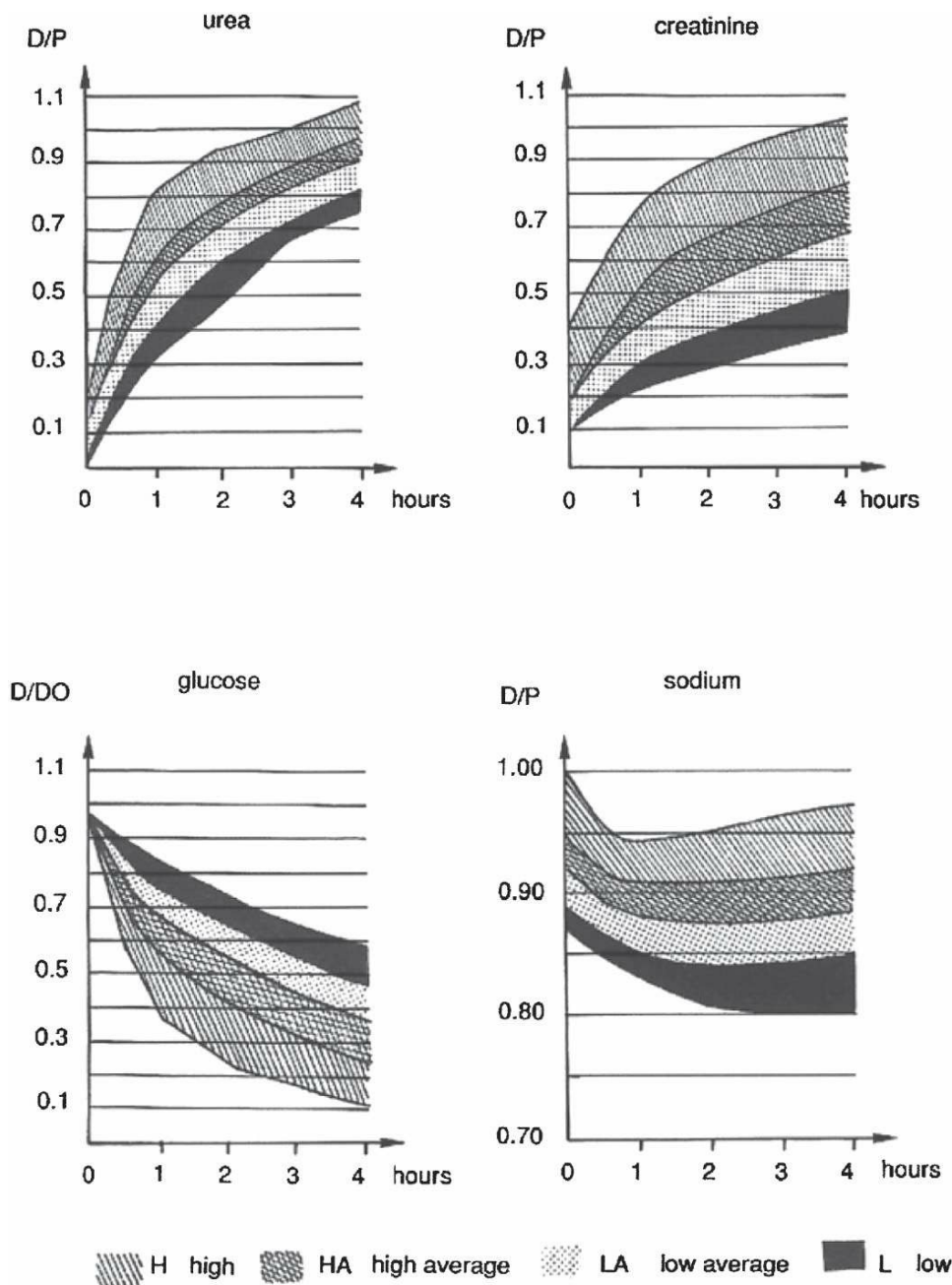

FIGURE 21.7 Standard peritoneal equilibration curves for urea, creatinine, and sodium, as well as glucose absorption showing ranges of values for high, high-average, low-average, and low transporters. (Modified from Twardowski et al. Peritoneal equilibration test. *Perit Dial Bull.* 1987;7:138.)

2. **Low transporters**, in contrast, have slower and less complete equilibration for urea and creatinine, reflecting low membrane permeability and/or small effective peritoneal surface area. They thus have low D/P_{Ur} , D/P_{Cr} , and D/P_{Na} and high $D/D_0 G$ with good net ultrafiltration. Dialysate protein losses are lower, and serum albumin values tend to be higher.
3. **High-average and low-average transporters** have intermediate values for these ratios and for ultrafiltration and protein losses.
4. **Clinical implications of transporter type.** High transporters tend to dialyze relatively well but to ultrafiltrate poorly, whereas low transporters ultrafiltrate well but dialyze poorly, although these issues are often masked while residual renal function is still substantial.

Theoretically, high transporters do best on peritoneal dialysis regimens that involve frequent short-duration dwells (e.g., APD) so that ultrafiltration is maximized. Conversely, low transporters should do best on regimens based on long-duration, high-volume dwells so that diffusion is maximized. In practice, in most units, patient lifestyle and other nonmedical issues influence the peritoneal prescription more than transport status, and low transporters can be well managed on APD, while high transporters can do CAPD provided the long nocturnal dwell is managed appropriately.

- B. **Net fluid removal.** Net fluid removal depends on the balance between peritoneal ultrafiltration and peritoneal fluid absorption. In a given patient, lymphatic flow rate and the transport qualities of the membrane are subject to change. In clinical practice, fluid removal in peritoneal dialysis can be enhanced by the following:
1. Maximizing the osmotic gradient
 - a. Higher tonicity dwells (e.g., 4.25% dextrose)
 - b. Shorter duration dwells (e.g., APD)
 - c. Higher dwell volumes
 2. An osmotic agent with a higher reflection coefficient (e.g., icodextrin)
 3. Increasing urine output (e.g., with diuretics)

As is shown in Figure 21.8, the net fluid removal with a 1.5% 2-L dextrose dwell is maximal in the first hour, and intraperitoneal volume is greatest after 90 minutes. After this time, the volume being ultrafiltered is less than that being resorbed, and by 6–10 hours, the intraperitoneal volume falls below 2 L, and the patient is achieving net fluid gain. If the more hypertonic 4.25% dextrose dialysis solution is used, initial fluid removal is greater and more sustained, and intraperitoneal volume is greatest after about 3 hours and will not fall below 2 L until after many hours.

The effect of larger dwell volumes on net fluid removal is complex. On the one hand, fluid removal increases because the osmotic gradient persists longer due to the greater quantity of glucose in the peritoneal cavity and because the effective surface area over which water is transported is likely increased. On the other hand, fluid removal may decrease because intraperitoneal pressure rises (Fig. 21.5), decreasing the hydrostatic gradient that favors ultrafiltration and promoting peritoneal fluid absorption into the tissues and lymphatics. The net effect of these forces varies from patient to patient and is difficult to predict.

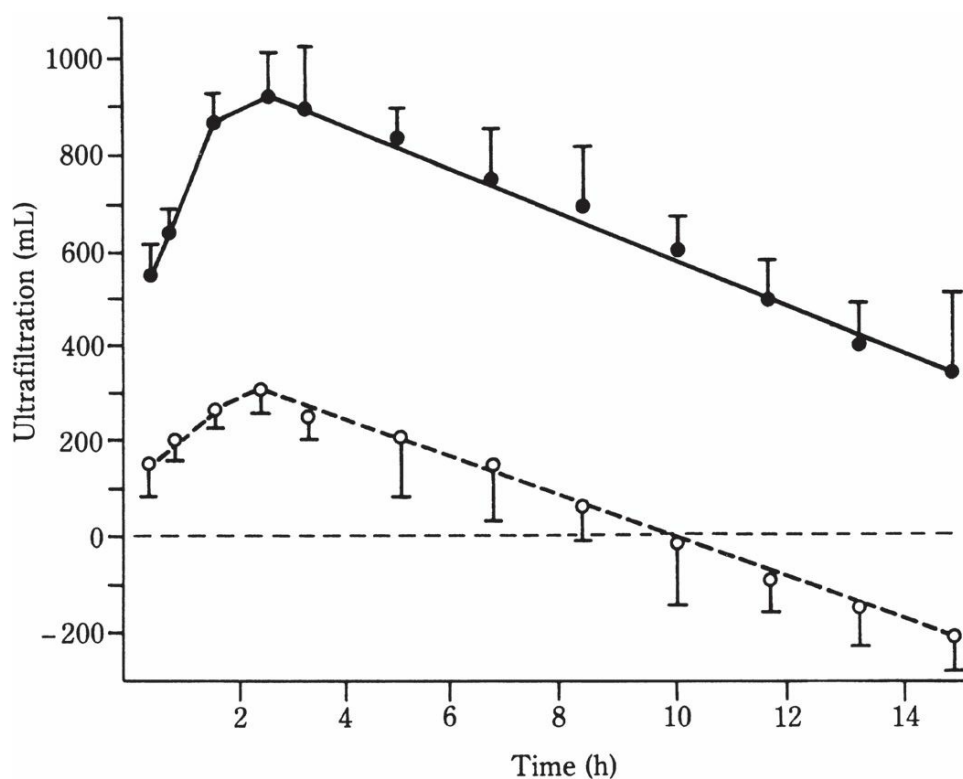

FIGURE 21.8 Ultrafiltration volume (volume drained minus volume instilled) as a function of time after infusion of dialysis solution containing 1.5% dextrose (1.35% glucose, *open circles*) or 4.25% dextrose (3.86% glucose, *closed circles*). (Modified from Diaz-Buxo JA. Intermittent, continuous ambulatory and continuous cycling peritoneal dialysis. In: Nissenson AR, et al., eds. *Clinical Dialysis*. Norwalk, CT: Appleton-Century-Crofts; 1984.)

- C. **Peritoneal clearance.** Clearance for a given solute is defined as the volume of plasma cleared of that solute per unit time. Clearance in peritoneal dialysis is the net result of the effects of solute removal by diffusion plus ultrafiltration minus solute gain via fluid absorption. Clearance is usually calculated as quantity of solute removed over a given period divided by the average plasma concentration of that solute during the removal period. Clearance is maximal at the start of the dwell, when both diffusion and ultrafiltration are greatest, but becomes less as both urea concentration and glucose osmotic gradients diminish as the dwell proceeds. However, because peritoneal clearance is measured per day or per week rather than per minute or per hour, average values of clearance are calculated by the usual measures of adequacy.

Peritoneal clearance can be increased by (a) maximizing time on peritoneal dialysis (i.e., no “dry time”), (b) maximizing concentration gradient (i.e., more frequent exchanges as in APD and larger dwell volumes), (c) maximizing effective peritoneal surface area (i.e., larger dwell volumes), and (d) maximizing peritoneal fluid removal (as described earlier).

The mechanism by which increasing dwell volumes augment clearance is sometimes confusing. Larger dwell volumes enhance urea and creatinine diffusion from blood to dialysate because the greater volume makes the solute concentration gradient stay higher for longer. Also, effective peritoneal surface area may increase because of recruitment of more membrane by the greater fluid volume, and consequently MTAC values may rise.

This effect tends to be modest or absent once volumes exceed 2.5 L in adults, presumably because all of the available membrane has been recruited. These two effects increase diffusive clearance even though D/P ratios tend to be a little lower when larger dwell volumes are used. Another aspect of larger dwell volumes that tends to decrease clearance is the effect to diminish ultrafiltration slightly, which lowers the amount of solute removed by convective transport. These last two factors conspire to limit the increase in clearance with higher dwell volumes. For example, a switch from 2.0- to 2.5-L dwells represents a 25% increase in infused volume but might, for example, be associated with a decrease in D/P ratios by 3% and of ultrafiltration by 5%, limiting the increase in clearance to about 20%.

Urea versus creatinine: Changes in the peritoneal dialysis prescription alter urea and creatinine clearances to different degrees because the latter is more time-dependent. Thus, a switch from CAPD to APD without a day dwell may lead to a much more marked decrease in creatinine than in urea clearance, whereas the introduction of a long day dwell in APD will cause a disproportionately greater enhancement in creatinine clearance. These effects are especially marked in low transporters, in whom creatinine clearance is particularly time-dependent, as reflected by the flat shape of the creatinine equilibration curve.

1. **Measurement of clearance.** Peritoneal clearance per day in peritoneal dialysis is easily measured and corresponds to the total daily dialysate drain volume multiplied by the solute concentration in that dialysate and divided by the simultaneously obtained plasma concentration of the same solute. Stated more simply, clearance equals the drain volume multiplied by the D/P ratio for the solute concerned.

In CAPD, the plasma urea level does not change significantly during the day because dialysis is continuous. Thus, the plasma sample can be taken at any convenient time during the day that dialysate is collected for analysis. In APD, there is significantly more intense dialysis at night than in the daytime; therefore, a constant plasma urea cannot be assumed, though variation is modest. Ideally, the plasma sample should be taken in the middle of the noncycling period (usually mid-afternoon) when the urea is about halfway between its lowest level (in the morning after cycling) and its highest level (at night before cycling).

Clearance is measured per day but expressed per week. It is conventional to normalize urea clearance to total-body water (V), which is typically estimated using the Watson or Morgenstern equations (see Chapter 25 and Appendix B). Creatinine clearance is normalized to 1.73 m² surface area, which is estimated using the formula of DuBois or Gehan and George (See Chapter 25 and Appendix B).

2. **Examples of peritoneal clearance calculations.** See Chapter 25.

D. **Sodium removal.** In peritoneal dialysis, it is helpful to consider sodium removal separately from water removal. As already mentioned, ultrafiltration in peritoneal dialysis involves sodium sieving so that water losses are proportionately greater than sodium losses. At the end of a 4-hour dwell using 132 mM sodium dialysis solution, the sodium level in the drained dialysate typically will have fallen to about 128 mM (Fig. 21.7). In the early part of a dwell, dialysate sodium falls to an even greater extent, because it is being diluted by

ultrafiltrate containing only about 65 mM sodium. This hyponatric effect of ultrafiltration is partly counteracted by diffusion of sodium from body tissues to dialysate. Thus, late in the dwell, when ultrafiltration has slowed, diffusion will have increased the dialysate sodium back up to about 128 mM. Overall, net sodium removal with a 4-hour, 1.5% dextrose, 2-L exchange is minimal, although with a 4-hour, 4.25% dextrose, 2-L dwell, sodium removal typically is in excess of 70 mmol. An alternative way of increasing sodium removal is to use dialysis solutions with a lower sodium concentration. With such low sodium solutions, diffusive sodium removal is increased, but greater concentrations of glucose are required to achieve the same osmotic effect. Such lower sodium dialysis solutions can be prepared but are not commercially available.

E. **Protein losses.** Obligatory dialysate protein losses are a feature of peritoneal dialysis and typically average 5–10 g daily. Half of the protein lost is albumin. These losses are probably the major cause of the slightly lower serum albumin levels typically seen in peritoneal dialysis patients compared with hemodialysis patients. Albumin losses are greatest, and serum albumin is lowest, in high transporters. The losses or clearances of large-molecular-weight proteins such as albumin are relatively constant during the course of a dwell. Low-molecular-weight proteins (such as lysozyme) are lost as well, and their clearance behaves more like that of creatinine, being highest during the initial part of a dwell, and then falling off markedly as the dwell proceeds.

Protein losses are believed to occur via a relatively small number of large pores that correspond to interendothelial clefts. Peritoneal absorption of fluid is a form of “bulk flow” and so involves protein as well as other solutes. It thus acts to decrease net peritoneal protein losses.

During peritonitis, protein losses increase markedly for a number of days, presumably due to an increase in effective peritoneal surface area due to increased peritoneal vascularity. This effect is, in part, mediated by prostaglandins. Protein losses on intermittent peritoneal dialysis regimens appear to be somewhat less per day than on continuous regimens, presumably because protein losses are decreased during the “dry” interdialytic periods.

There is a school of thought that protein losses during peritoneal dialysis are not completely a bad thing, but rather, that with the lost protein and albumin the body effectively excretes tightly protein-bound toxins that are difficult to remove by other means. The extent of this “benefit” of peritoneal dialysis remains to be clarified. Attempts to replicate loss of protein-bound uremic toxins by performing hemodialysis using very permeable, protein-losing membranes have not shown a clear-cut clinical benefit.

V. **RESIDUAL RENAL FUNCTION.** There is evidence that residual renal function persists longer and at a higher level in chronic peritoneal dialysis patients than in those on hemodialysis. Residual function contributes to salt and water removal and to clearance of both small- and medium-size molecular-weight solutes. Creatinine clearance is disproportionately high with residual renal function, as tubular secretion contributes to the overall clearance to a relatively large extent. The opposite is the case with urea clearance, where tubular resorption of urea acts to reduce urea excretion. There is evidence that the average of urea and creatinine clearance is a

reasonable estimate of true glomerular filtration rate in the failing kidney, and this estimate is used when calculating the renal contribution to total creatinine clearance in patients on peritoneal dialysis. Residual renal function has been shown to be predictive of patient outcome in peritoneal dialysis, perhaps because it is associated with better preserved renal endocrine and metabolic function and superior volume homeostasis, as well as greater small- and large-molecule clearance.

References and Suggested Readings

- Crossen TT, et al. Quantification of free water transport during the peritoneal equilibration test. *Perit Dial Int*. 2009;29:523–527.
- Devuyst O, Rippe B. Water transport across the peritoneal membrane. *Kidney Int*. 2014;85:750–758.
- Durand PY. Measurement of intraperitoneal pressure in peritoneal dialysis patients. *Perit Dial Int*. 2005;25:333–337.
- Flessner M. Water-only pores and peritoneal dialysis. *Kidney Int*. 2006;69:1494–1495.
- Flessner MF. The role of extracellular matrix in transperitoneal transport of water and solutes. *Perit Dial Int*. 2001;21(suppl 3):S24–S29.
- Heimbürger O. Peritoneal transport with icodextrin solution. *Contrib Nephrol*. 2006;150:97–103.
- Heimbürger O, et al. A quantitative description of solute and fluid transport during peritoneal dialysis. *Kidney Int*. 1992;41:1320–1332.
- Krediet RT, Struijk DG. Peritoneal dialysis membrane evaluation in clinical practice. *Contrib Nephrol*. 2012;178:232–237.
- La Milia V, et al. Mini-peritoneal equilibration test: a simple and fast method to assess free water and small solute transport across the peritoneal membrane. *Kidney Int*. 2005;68:840–846.
- La Milia V, et al. Functional assessment of the peritoneal membrane. *J Nephrol*. 2013;26(suppl 21):120–139.
- Ni J, et al. Aquaporin-1 plays an essential role in water permeability and ultrafiltration during peritoneal dialysis. *Kidney Int*. 2006;69:1518–1525.
- Rippe B, et al. Fluid and electrolyte transport across the peritoneal membrane during CAPD according to the three-pore model. *Perit Dial Int*. 2004;24:10–27.
- Stachowska-Pietka J, et al. Computer simulations of osmotic ultrafiltration and small solute transport in peritoneal dialysis: a spatially distributed approach. *Am J Physiol Heart Circ Physiol*. 2012;302:F1331–F1341.
- Twardowski ZJ, et al. Peritoneal equilibration test. *Perit Dial Bull*. 1987;7:138.
- Waniewski A, et al. Distributed modeling of osmotically driven fluid transport in peritoneal dialysis: theoretical and computational investigations. *Am J Physiol Renal Physiol*. 2009;296:1960–1968.

In this chapter, solutions and equipment for the various forms of chronic peritoneal dialysis (PD) are described. Apparatus for acute PD is reviewed in Chapter 24.

I. **CONTINUOUS AMBULATORY PERITONEAL DIALYSIS (CAPD)** . In CAPD, dialysis solution is constantly present in the abdomen. The solution is typically changed four times daily, with a range of three to five times, depending on individual patient requirements. Drainage of “spent” dialysate and inflow of fresh dialysis solution are performed manually, using gravity to move fluid into and out of the peritoneal cavity. Technically, PD solution flows into the peritoneal cavity, and dialysate drains out (i.e., the solution does not become dialysate until dialysis has occurred, although the term “dialysate” is commonly used for fresh as well as for used or “spent” solution). In this chapter, the term dialysate is used correctly to refer only to PD solution after it has been instilled into the peritoneal space.

A. **Dialysis solutions.** CAPD solutions are packaged in clear, flexible plastic bags, typically made from polyvinyl chloride. Some newer PD solutions are packaged with the different solution components in two-chamber (or three-chamber) bags, which are mixed before infusion into the peritoneal cavity.

1. **Dialysis solution volumes.** For adult patients, CAPD solutions are available in volumes of 1.5, 2.0, 2.25, 2.5, or 3.0 L, depending on the manufacturer. The commonly used bags are routinely overfilled by about 100 mL to allow for flushing, as will be described in a subsequent section. The standard volume prescribed has been 2.0 L, but 2.5 L is also widely used. Generally, larger volumes are prescribed in order to increase solute clearance, but they may not always be tolerated by patients because of symptoms due to the consequent increase in intraperitoneal hydrostatic pressure.
2. **Dialysis solution glucose, pH, and glucose degradation products (GDPs).** Dextrose (glucose) is the osmotic agent commonly used in CAPD solutions, and preparations containing 1.5%, 2.5%, and 4.25% dextrose (as glucose monohydrate, MW 198) are routinely available and are labeled as such in North America. The true anhydrous dextrose or glucose concentrations (MW 180) in these solutions are 1.36%, 2.27%, and 3.86%, respectively, and this is how they are typically labeled in Europe. The approximate osmolarities of these solutions are 345, 395, and 484 mOsm/L, respectively.

The heat sterilization of glucose leads to generation of glucose degradation

products (GDPs), which may have toxic effects both on the peritoneal membrane and systemically. Less GDPs are generated when glucose is heat sterilized at low pH, so in order to minimize GDP generation, the pH of standard lactate-based PD solutions is kept at about 5.5 during heat sterilization. Lowering pH further would decrease GDPs even more, but would also cause infusion pain in patients. A pH of 5.5 on infusion is normally well tolerated, and solution pH rises rapidly as bicarbonate diffuses into the peritoneal cavity from the plasma. However, some patients complain of pain during inflow. This pain can be relieved by neutralizing the dialysis solution pH with alkali prior to instillation.

The low pH of PD solution may have adverse effects on leukocytes, impairing their ability for phagocytosis and bacterial killing and may even be harmful to the peritoneal membrane. Therefore, another strategy to reduce GDP generation has been introduced. This is the use of two-compartment solution bags (Fig. 22.1). In one compartment, the glucose is heat sterilized at a very low pH (about 3.2), under which conditions the formation of GDPs is reduced even further. In the other compartment, the rest of the solution is maintained at an alkaline pH during sterilization. At the time of use, the two compartments are allowed to mix, bringing the pH of the resultant combined solution to normal. The end result, therefore, is a low GDP, normal pH PD solution.

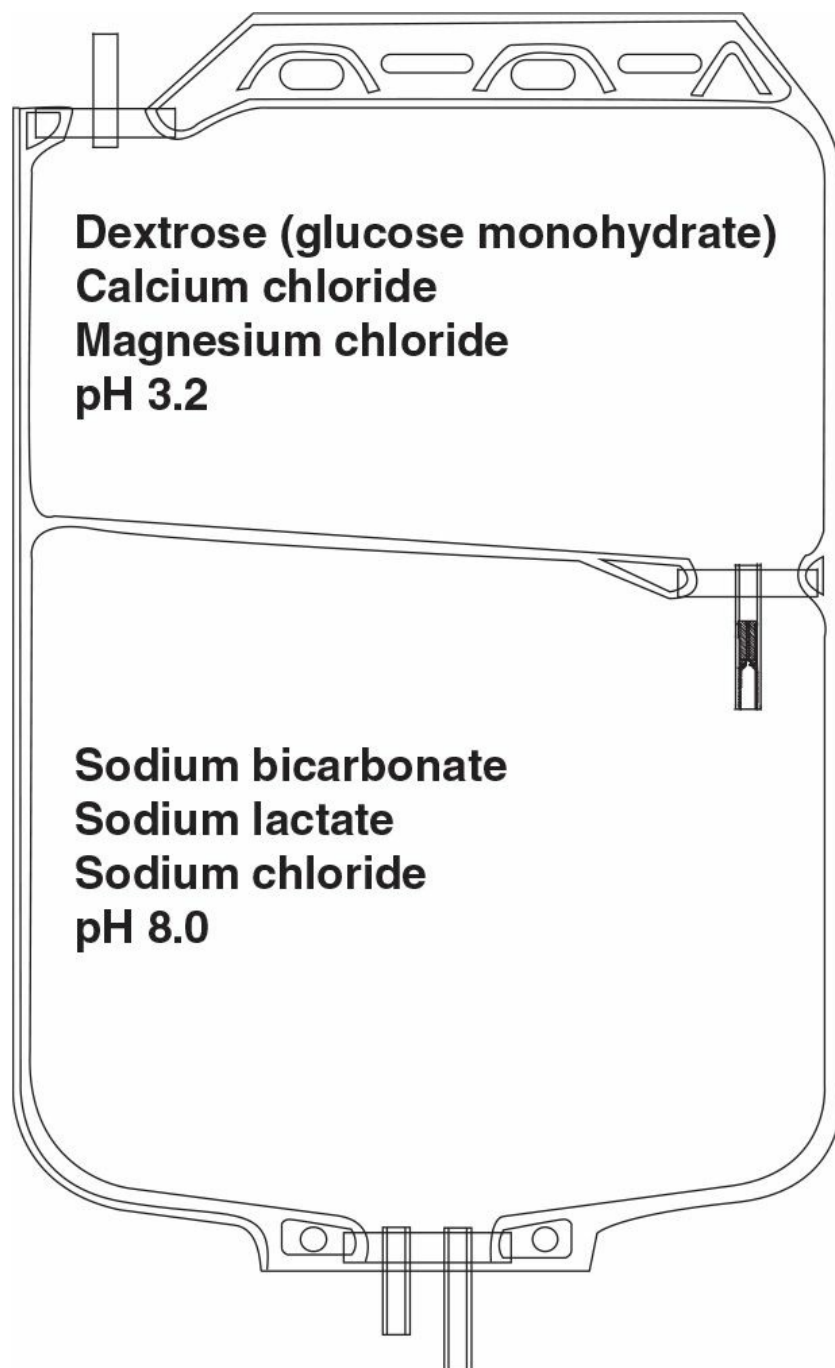

FIGURE 22.1 Two-compartment PD solution bag to allow delivery of a normal pH solution with low GDPs with or without bicarbonate buffer.

- Dialysis solution buffer and pH.** Most commonly marketed PD solutions contain lactate as the bicarbonate-generating base, usually in a 40-mM, or occasionally a 35-mM, concentration. The lactate diffuses across the peritoneal membrane into the bloodstream and is soon metabolized into bicarbonate. A more direct way to supply bicarbonate is to add it directly to the dialysis solution. However, solutions containing bicarbonate and no CO_2 have a high pH, at which calcium and magnesium precipitate. For this reason, it is not possible to store *bicarbonate-buffered* solution in a single-bag system. A variation of the two-compartment-bag system described earlier to limit generation of GDP can be used to enable inclusion of bicarbonate in PD solution. A solution containing calcium and magnesium, a small amount of acid, and other electrolytes is put into one of the compartments, and bicarbonate-containing solution is

kept in another compartment. At the time of use, the solutions in the two compartments are mixed together, and the small amount of acid in the calcium/magnesium solution reacts with bicarbonate to generate carbonic acid and CO_2 , which keeps the pH of the final solution in the physiologic range, at which calcium and magnesium remain in solution. The process is very similar to providing bicarbonate dialysis solution for hemodialysis from a two-component set of concentrates.

Thus, there are at least three commercially available two-bag systems for PD solutions. The Balance solution from Fresenius uses only lactate as the base. The two-bag system is used to limit the formation of GDP by sterilizing the glucose-containing component at low pH. Physioneal, from Baxter, contains both bicarbonate and lactate, and the two-bag system is used both to limit generation of GDP during sterilization and to allow bicarbonate to be used. Bicavera, from Fresenius, contains only bicarbonate and no lactate, and here again, the two-bag system allows use of bicarbonate and also greatly reduced generation of GDP (Table 22.1).

Because these two-bag system solutions are at physiologic or near-physiologic pH after mixing, and because they contain greatly reduced amounts of GDPs, they are theoretically more biocompatible than standard one-bag solutions where the pH is about 5.5. The hope was that these biocompatible solutions would lead to better long-term preservation of peritoneal transport function, including ultrafiltration. It was also hoped that they would enhance peritoneal host defenses and thereby decrease peritonitis rates, and that their use would result in lower serum GDP levels and ultimately better preservation of residual renal function, and that all this would translate into improved technique and patient survival on PD.

There is evidence that each of these dual-bag solutions is effective in dealing with infusion pain. However, this complication occurs only in fewer than 5% of patients using standard low pH PD solutions. With regard to other more important outcomes, results from randomized controlled trials have shown inconsistent results. The recent balANZ study showed a significantly lower peritonitis rate with the Balance solution, but this has not been confirmed in other trials, and a meta-analysis has been negative (Johnson, 2012; Cho, 2014). Some trials have shown better preservation of residual renal function but have also shown less effective ultrafiltration, leading to concern that the improved preservation of renal function with this new solution is simply a consequence of hypervolemia (Davies, 2013). Randomized studies have not been large enough to allow conclusions about long-term patient or technique survival. These biocompatible solutions are widely used in Europe and in parts of Asia but very little in North America and elsewhere, partly because of the lack of consistent high-level evidence supporting their use and partly because of their higher cost.

4. **Dialysis solution electrolyte concentrations.** The electrolyte concentrations of CAPD solutions vary little by manufacturer. The standard formulations from the three large international manufacturers are shown in Table 22.1. They contain no potassium, and sodium levels are mostly 132–134 mM. Higher sodium concentrations would lead to less diffusive removal of sodium during dwells. Lower sodium solutions have been proposed as a means of augmenting sodium removal, but would require more glucose to maintain a

given osmolarity.

With the widespread use of calcium carbonate or calcium acetate as phosphate binders, PD solutions containing 2.0–2.5 mEq/L (1.0–1.25 mM) rather than 3.5 mEq/L (1.75 mM) calcium are increasingly used with the goal of reducing the incidence of the hypercalcemia that is sometimes associated with oral calcium and vitamin D administration. This also protects against adynamic bone disease, which was previously common in PD patients. However, lower calcium PD solutions have been associated with higher plasma parathyroid hormone (PTH) levels. PD solutions typically contain magnesium levels of 1.0 or 0.5 mEq/L (0.5 or 0.25 mM), and this can occasionally result in magnesium depletion.

TABLE

22.1

Commonly Available Peritoneal Dialysis Solution Formulations

	Manufacturer	pH	Osmotic Agent	Na (mM)	Ca (mM)	Mg (mM)	Lactate (mM)	Bicarbonate (mM)	Pouches
Dianeal PD1	Baxter	5.5	Glucose	132	1.75	0.75	35	0	1
Dianeal PD4	Baxter	5.5	Glucose	132	1.25	0.25	40	0	1
Stay safe 2/4/3	FMC	5.5	Glucose	134	1.75	0.5	35	0	1
Stay safe 17/19/18	FMC	5.5	Glucose	134	1.25	0.5	35	0	1
Nutrineal	Baxter	6.5	Amino acids	132	1.25	0.25	40	0	1
Extraneal	Baxter	5.5	Icodextrin	132	1.75	0.25	40	0	1
Physioneal 35	Baxter	7.4	Glucose	132	1.75	0.25	10	25	2
Physioneal 40	Baxter	7.4	Glucose	132	1.25	0.25	15	25	2
Balance	FMC	7.4	Glucose	134	1.25	0.5	35	2.5	2
Bicavera	FMC	7.4	Glucose	134	1.75 1.25 1.75	0.5	0	34	2

These may differ slightly in name and in formulation from region to region.

All glucose-based solutions are available in three strengths (1.36, 2.27, and 3.86 mg/dL of glucose, equivalent to 1.5, 2.5, and 4.25 mg/dL of dextrose as glucose monohydrate.

To convert calcium from mmol/L (mM) to mg/dL multiply by 4.

To convert magnesium from mmol/L (mM) to mg/dL multiply by 2.43.

FMC, Fresenius Medical Care.

5. **Non-glucose solutions.** Glucose as an osmotic agent in PD has the advantage of being familiar, relatively safe, and inexpensive, and also is a source of calories. There is concern, however, that instillation of large amounts of glucose into the peritoneal cavity predisposes patients to hyperglycemia, dyslipidemia, obesity, and to long-term peritoneal membrane damage, both directly and via GDPs and the formation of advanced glycosylation end products. Glucose-based solutions are not very effective in high transporters, and inadequate ultrafiltration may result. Alternative osmotic agents are available.

a. **Icodextrin.** This is a polyglucose solution and is widely used. It is iso-osmolar and induces ultrafiltration by its oncotic effect (Mistry, 1994). Absorption of polyglucose is by the lymphatics and so is much slower compared with glucose. The oncotic effect and the associated ultrafiltration are therefore more sustained than with glucose. For this reason, the main indication to use icodextrin is for the long nocturnal dwell in CAPD and for the long day dwell in automated peritoneal

dialysis (APD), especially in patients with ultrafiltration failure. It is generally used for just one dwell daily as it is no more effective than glucose for short dwell times. Icodextrin use is associated with unphysiologic blood levels of maltose and maltotriose, but no associated toxicity has been identified. The increased maltose levels will cause interference with the glucose dehydrogenase pyroquinolinequinone assay (which reacts with both glucose and maltose) for blood glucose measurements. Therefore, blood glucose should be measured with other methods in patients using icodextrin. In addition, use of icodextrin is associated with mild translocational hyponatremia (owing to movement of sodium-poor fluid from cells to the extracellular fluid). Measured amylase levels can be factitiously low, as a result of interaction between metabolites of icodextrin and commonly used amylase assays.

Icodextrin has been shown in randomized controlled trials to improve ultrafiltration and volume status in PD patients, though not convincingly to reduce blood pressure (Davies, 2003). It has also been shown to improve glycemic control, decrease weight gain, and lessen glucose-induced lipid abnormalities (Cho, 2013; Li, 2013). There is some evidence of better long-term preservation of peritoneal membrane function (Davies, 2005). Disadvantages are its extra cost, occasional skin reactions, and rare sterile peritonitis episodes.

- b. **Amino acid-based solutions.** These are used for nutritional supplementation as they are largely absorbed by the end of a 4- to 6-hour dwell (Jones, 1998). Studies have shown them to be modestly effective in nutritionally compromised patients (Lo, 2003). They are reasonably effective osmotically (comparable to the 1.36% glucose solution) but can be used only once daily because in larger amounts they tend to cause acidosis, as well as a rise in the blood urea. These side effects can be addressed with oral alkali therapy and more dialysis, respectively.
 6. **Sterility and trace metals.** The preparation of PD solutions is carefully regulated to ensure that the final product is bacteriologically safe and has very low concentrations of trace metals.
 7. **Dialysis solution temperature.** PD solutions are usually warmed to body temperature prior to inflow. They can be instilled at room temperature, but uncomfortable lowering of the body temperature and shivering can result. The best warming method is to use a heating pad or special oven. Microwave ovens are frequently used, but this is not recommended by most manufacturers because “hot spots” may be produced during heating, in particular, in the transfer sets. When using a microwave oven, great care must be taken to avoid overheating of the dialysis solution as this can chemically alter the dextrose and may cause discomfort on instillation. Also, accidental boiling of the solution in a confined space may cause an explosion. Heating methods that involve immersing the PD solution container completely in water are also not recommended because contamination can result.
- B. **Transfer sets.** The PD solution bag is connected to the patient’s peritoneal catheter by a length of plastic tubing called a “transfer set” (also sometimes called a “giving set”). There are three major types of transfer sets, each requiring a different method of performing the

CAPD exchange. For the purpose of discussion, we will refer to them as the straight transfer set, the Y transfer set, and the double-bag system. Note that some transfer sets are connected to the peritoneal catheter via a short extension or adapter tubing (see what follows).

1. **Straight transfer set.** This system is now rarely used because it is associated with high rates of peritonitis. However, a brief description is helpful in understanding how more modern systems have evolved.
 - a. **Design.** The straight transfer set is a simple plastic tube. One end connects to the peritoneal catheter and the other end to the dialysis solution bag. All exchanges are performed by making and subsequently breaking the connection between the transfer set and the bag. This connection typically involves a spike or a Luer lock.
 - b. **Exchange procedure.** Dialysis is performed as follows:
 1. Dialysis solution is instilled by gravity.
 2. The empty bag and transfer set are rolled up and stored in a pouch carried on the patient's body.
 3. Dwell time is typically 4–8 hours.
 4. The bag is unrolled and placed on the floor. The dialysate is drained into the bag. The bag is then disconnected from the transfer set and discarded.
 5. A new bag is attached to the transfer set using a spike or Luer lock.
 6. Fresh dialysis solution is instilled.

Once every several months, the transfer set is changed. Extended-life transfer set tubing allows patients to dialyze for 6 months between transfer set changes.

2. **The Y set (Fig. 22.2)**
 - a. **Design.** This is a Y-shaped piece of tubing that is attached by its stem to the patient's catheter or extension tubing at the time of each solution exchange. During the exchange, the afferent and efferent limbs of the Y are attached to a bag of fresh PD solution and to a drain bag, respectively. In some cases, the drain bag is the empty solution bag that was used in the previous exchange. Most Y sets are not connected directly to the catheter but rather to a short (15–24 cm) adapter or extension tubing inserted between the catheter and the stem of the Y set. This adapter/extension tubing is sometimes confusingly called a transfer set, but in this chapter that term is reserved for the tubing that connects the solution bag and drain bag to the extension tubing and catheter. The adapter/extension tubing avoids the need for, and the risk of damage associated with, repeated clamping of the catheter.
 - b. **Exchange procedure**
 1. **pike/lock:** The fresh bag of PD solution is attached to the afferent limb of the Y set via a spike or Luer lock.
 2. **Connect:** The stem of the Y set is connected to the extension tubing.

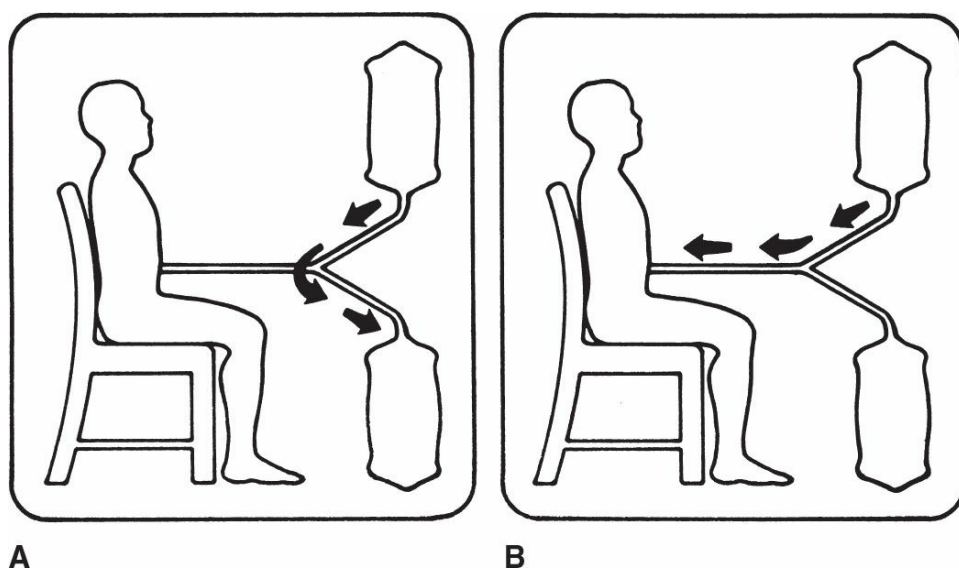

A

B

FIGURE 22.2 Y-set system using flush-before-fill. **A:** A small volume of fresh dialysis solution is drained directly into the drainage bag (either before or just after drainage of the abdomen). This act washes away any air or bacteria that may be present in the afferent limb of the Y. **B:** Fresh solution is introduced through the rinsed transfer set. With the pre-attached double-bag system, the purpose of the “flush-before-fill” step is solely to flush out any air in the tubing.

3. Drain: The stem and efferent limb of the Y are unclamped, and the spent dialysate is drained from the peritoneal cavity into the drain bag.
4. Flush: With the stem of the Y set clamped, approximately 100 mL of fresh solution is flushed from the new bag through the afferent limb of the Y into the efferent limb and so into the drain bag.
5. Fill: The efferent limb is clamped and the stem unclamped, and the peritoneal cavity is filled from the new bag of PD solution.
6. Disconnect: The Y set is then disconnected from the adapter/extension tubing.

The Y set was developed to free patients from the requirement to remain attached to the transfer set and empty bag between exchanges. Early studies revealed a more important benefit—a peritonitis rate significantly lower than that with the straight set. This is thought to be due to the flush-before-fill procedure used to prime the tubing. Bacteria that may be introduced during the connection procedure are washed out of the Y set into the empty drainage bag rather than into the patient, as happens with the straight set. Also, because the tubing and bags are disconnected from the patient between exchanges, less mechanical stress may be placed on the catheter exit site and tunnel. This may result in fewer episodes of minor trauma to the catheter exit site and tunnel, and therefore to fewer exit site and tunnel infections and associated peritonitis. Because of this lower peritonitis rate and the convenience of allowing the patient to disconnect between exchanges, Y-set systems increasingly displaced the straight system as the transfer set of choice from the mid-1980s onward.

3. Pre-attached double-bag Y-set systems

- a. **Design.** These systems are a variant of the Y set in which the solution bag comes preattached to the afferent limb of the Y, obviating the need for any spike or Luer

lock connection. The drain bag is similarly preattached to the efferent limb, and the only connection the patient needs to make is between the transfer set and the adapter/extension tubing. A flush-before-fill step is still performed, but the purpose is only to flush out residual air and not to prevent peritoneal cavity contamination, as this is no longer relevant in the absence of a need to make a transfer set-to-solution bag connection.

These are now by far most popular systems because of their ease of use and because of evidence that they are associated with even lower rates of peritonitis than the standard Y sets (Kiernan, 1995).

b. Exchange procedure

1. **Connect:** The patient connects the new transfer set to the adapter/extension tubing.
2. **Drain:** The stem and efferent limb are unclamped, and spent dialysate is drained from the peritoneal cavity into the drain bag.
3. **Flush:** The stem is clamped, and the afferent limb of the Y is opened by breaking a “frangible” in the tubing. Then 100 mL of PD solution is flushed through from the fill bag to the drain bag to remove residual air from the tubing.
4. **Fill:** The efferent limb is clamped, the stem is unclamped, and fresh PD solution is run into the peritoneal cavity.
5. **Disconnect:** All limbs are clamped, and the transfer set is disconnected from the extension tubing.

C. Various connectors for PD. Over the years, a number of connectors and associated devices have been developed and marketed in an attempt to reduce the possibility of bacterial contamination while making either the catheter-to-transfer set or the transfer set-to-solution bag connections.

1. Catheter-to-transfer set (or adapter/extension tubing-to-transfer set) connection

- a. **Catheter connector.** Early in the history of CAPD, simple, plastic, plug-in connectors were used at the catheter-to-transfer set junction. Cracking of the plastic connector and accidental disconnection were frequent events that often led to peritonitis. A special Luer lock connector made of titanium was developed to prevent such problems. Titanium was chosen for its light weight and resistance to electrolyte-containing solutions. Designed for easier handling and a tighter connection, the new product functioned very well. Catheter-to-transfer set connectors constructed from more durable plastics are also available.
- b. **Quick connect-disconnect systems.** With the advent of the disconnect Y sets and double bags, the need arose for an easy yet sterile connection at the catheter-to-transfer set joint (or adapter/extension tubing-to-transfer set joint). A number of connector designs for this purpose are now available. Typically, they include a “Luer Lock”-type mechanism with a recessed orifice and an iodine-impregnated cap to minimize the risk of contamination. A more elaborate device is the “Stay Safe” device from Fresenius Medical Care, which regulates the fill and drain cycles as well as making the connection to the adapter tubing.

2. **Transfer set-to-solution bag connection.** With the advent of double-bag systems, technologies to facilitate the connection between the transfer set and the PD solution bag are less relevant. However, some of them are still used, and brief mention will be made of them.
 - a. **Spike-and-port design.** The spike-and-port design is the oldest and simplest system used to connect the transfer set to the PD solution bag. It is operated by pushing a spike located at the end of the transfer set into a port on the solution bag.
 - b. **Easy-lock connectors.** Spiking the solution bag is difficult for many patients because it requires reasonably good vision, depth and sensory perception, and strength. Mistakes can result in contamination and subsequent peritonitis. The spike has thus been replaced in many transfer sets by a Luer lock- or screw-type system, resulting in easier insertion. A modified form contains a recessed fluid pathway to prevent accidental contamination, a reservoir that can be filled with an antiseptic solution (e.g., povidone-iodine), and a silicon O-ring to provide a tight seal.

II. **AUTOMATED PERITONEAL DIALYSIS.** APD, using a cycler, is now almost as widely used as CAPD across the world, and in some countries, including the United States, the majority of PD patients are treated this way. APD is traditionally divided into APD with a day dwell, also known as continuous cycling peritoneal dialysis (CCPD), and “day dry” APD, also known as nocturnal intermittent peritoneal dialysis (NIPD), although the combination of cycler therapy at night with multiple daytime exchanges is also commonly used (see what follows) (Fig. 22.3). In APD with a day dwell, the patient carries PD solution in the abdominal cavity throughout the day but performs no exchanges and is not attached to a transfer set. At bedtime, the patient hooks up to the cycler, which drains and refills the abdomen with solution, three or more times in the course of the night. In the morning, the patient, with the last dwell remaining in the abdomen, disconnects from the cycler and is free to go about daily activities. In day dry APD, the patient drains out fully at the end of the cycling period, and so the abdomen is “dry” all day. Because of the absence of a long-duration day dwell, clearances are generally lower on day dry APD, but its use may be indicated if there is good residual renal function or if there are mechanical contraindications to walking about with solution in the abdominal cavity (e.g., leaks, hernias, back pain).

A. **Cyclers.** These are machines that automatically cycle dialysis solution into and out of the abdominal cavity. Contemporary cyclers are not gravity dependent but instead use hydraulic pumps to deliver the solution from 3-, 5- or 6-L bags to a “fill bag” and from there into the abdomen. The solution in the fill bag is warmed before inflow. With the aid of pressure alarms, clamps, and timers, inflow, dwell, and outflow of solution is regulated and overfilling prevented.

Recent cycler models are small and light enough to pack in a large suitcase and carry on trips. Advanced design and computer technology make them simple to set up and operate. The patient typically sets only the start time, volume of solution to be used, dwell volume, and length of dialysis or stop time desired. The cycler calculates the timing of the exchanges, measures volume of ultrafiltrate, and optimizes drain and inflow time by measuring flow rates. The cycler changes from drain to fill when flow slows down rather

than waiting for a preset time. It also tests to determine whether flow has stopped because of obstruction. Some models incorporate “smart cards,” which can be used to program the cyclers prescription and to record the actual prescription delivered to the patient.

An extremely useful feature is the ability to draw dialysis solution from a separate solution container for the last instillation in the morning, called the “last bag option.” This last inflow, which will be in place throughout the day, may require a higher dextrose concentration than the other exchanges. More often, nowadays, the last bag option is used to deliver an alternative solution such as icodextrin or amino acids for the long day dwell.

Typically, patients spend 8–10 hours a night cycling. Dwell volumes range from 1.5 to 3.0 L, and the number of cycles usually varies from 3 to 10 per night. It is often possible to use a larger fill volume during APD compared with CAPD because of the lower intraperitoneal pressure in the recumbent position. A larger fill volume will increase clearance as well as ultrafiltration (owing to slower glucose absorption). The total amount of fluid used is typically between 8 and 18 L.

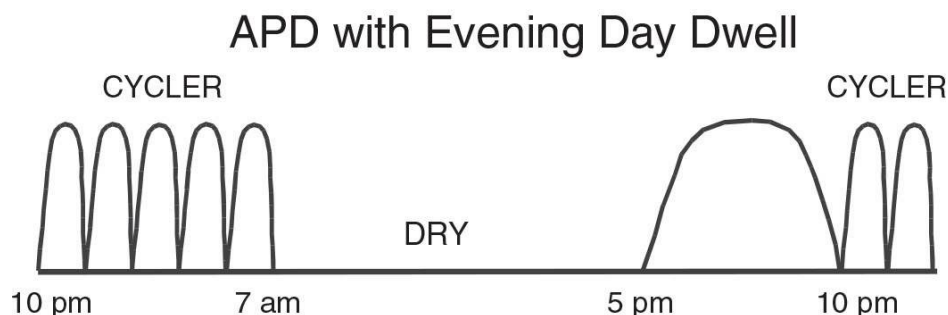
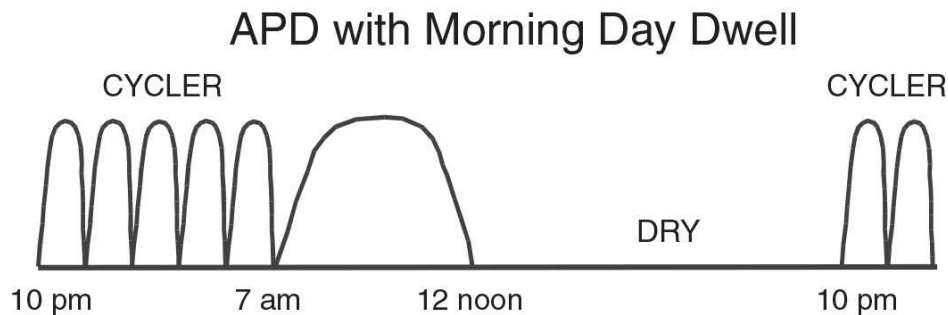
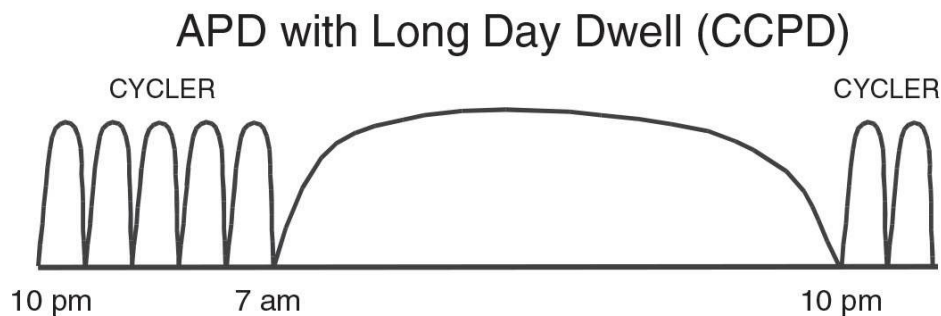
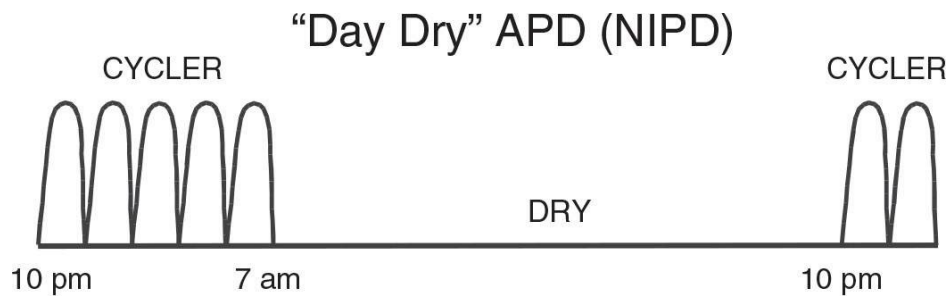

FIGURE 22.3 Visual representation of common CAPD, APD, and hybrid prescriptions.

- B. Dialysis solution.** Dialysis solution for APD is the same as that used for CAPD. Most cyclers are fed by a tube containing a multipronged manifold that can attach to as many as eight dialysis solution bags simultaneously to provide sufficient solution for the night. The total number of bags required, and thus the cost, can be reduced by using larger bags holding 3, 5, or 6 L of dialysis solution, although lifting these can be a problem for older and frailer patients. Because some cyclers can be fed from two or more bags simultaneously, with appropriate selection of the dextrose concentrations of the solutions being hung, a number of intermediate dextrose concentrations (e.g., between those commercially available) can easily be delivered. Low GDP solutions (both lactate-based and bicarbonate–lactate-based solutions) are available in large-volume bags suitable for APD, whereas pure bicarbonate solution is not. Amino acids are occasionally used during APD to provide nutritional support and to reduce glucose exposure. However, the fractional absorption of the amino acids in the bag is much lower because of the much shorter cycle duration during APD compared with CAPD. Icodextrin solution is not usually prescribed for delivery by cycler, except as a “last bag option.”
- C. APD connections**
1. **Transfer sets.** One set of plastic tubing serves to interconnect several solution containers to the cycler and to connect the cycler to the patient. Shorter, simpler, and less expensive solution delivery sets are constantly being developed.
 2. **Catheter–to–transfer set connection.** The catheter–to–transfer set connection must be made every night and broken every morning. Previously, many patients had a standard Luer lock connector at the end of the peritoneal catheter. The procedure for connecting the catheter connector to the transfer set was tedious because it required sterile procedure and a lengthy antiseptic scrub. This older connector has largely been replaced by new, quick connect–disconnect systems that require no manual disinfection and are therefore much easier to use. Most of these systems also may fit CAPD transfer sets, allowing APD patients to use the CAPD method whenever desired (e.g., when traveling).
 3. **Transfer set–to–solution bag connections.** The standard spike-and-port or, more often, Luer lock connections are used to connect the multipronged transfer set to the dialysis solution containers. It is ironic that this step, which has largely disappeared from CAPD with the dominance of double bags, has become commonplace again with the growth in use of APD. In order to minimize the risk of contamination, the newer cyclers allow for a flush option after this connection has been made. The same connection technologies used to assist CAPD patients with visual impairment, arthritis, or neuropathy can also assist APD patients in making the transfer set–to–container connections.
- D. Tidal peritoneal dialysis (TPD).** This variant of APD was designed to optimize solute clearance by leaving a significant volume of dialysis solution in the peritoneal cavity throughout the dialysis session. It was thought that this would allow diffusive clearance to continue throughout the cycling period. Initially, the peritoneal cavity is filled with a volume of solution selected to be as large as possible without causing discomfort. The volume used

depends on patient size and habitus, but is typically 2–3 L. When TPD was introduced, a 50 % tidal volume was common; for example, if 2 L is being used, the next fill volume (the tidal volume) is 1 L, the next drain volume is about 1 L, and so on. Clearances with TPD have been disappointing and, with usual solution volumes, are no better than those with similar amounts of solution delivered by conventional cycling. Clearance benefits may be seen with high-volume TPD where solution volumes are greater than 20 L, but these are not widely used because of high cost and inconvenience. Today, the commonest indications for TPD are to avoid low-drain alarms in patients with poor catheter function, or to avoid drain pain in patients who experience discomfort at the end of the drain phase. With this in mind, cyclers allow individualization of the tidal volume, and most commonly it is set to about 75%–85%. TPD cycles are quite short, usually totaling less than 60 minutes with dwell times for the replacement aliquot being only 10–40 minutes. The peritoneal cavity is drained completely at the end of the dialysis session but can also be drained every third or fourth cycle in order to avoid cumulative ultrafiltration leading to a progressively greater dwell volume. At the end of the cycler session, a day dwell can be left in or drained with the peritoneal cavity left day dry.

1. **Technical problems.** Classical high-volume TPD has a number of technical problems, making it difficult to recommend for routine use. Therefore, mainly low-volume TPD is currently used.
 - a. **Peritoneal catheter.** For classical high-volume TPD, the peritoneal catheter must have excellent inflow and drain characteristics as flow must be 180–200 mL/min during the drain phase. In contrast, low-volume TPD is often used to avoid alarms from low drain when the catheter function is poor.
 - b. **Cost.** In adults, the advantages of TPD in terms of clearance are seen only with 20–30 L of solution per treatment, and this is very expensive.
 - c. **Ultrafiltration computations.** The ultrafiltration volume must be calculated and added to the drain volume with each exchange; otherwise, the intra-abdominal volume will become progressively larger. TPD is best performed with newer cyclers that have been modified so that the outflow volume can be set to trigger a change to dialysate inflow mode. When the preset outflow volume is reached (e.g., 1.5 L), the machine switches immediately to inflow and infuses a fresh 1.5 L of dialysis solution. This system is quite different from that in most early cyclers, in which inflow/outflow cycles were regulated only by preset timers, not by volume.
 - d. **Overfill.** The risk of overfill of the peritoneal cavity with consequent symptoms of raised intra-abdominal pressure is greater with TPD than conventional APD, perhaps because TPD is often used when catheter function is suboptimal (Cizman, 2014). Some cyclers have safety settings in place to ensure full drainage of the day dwell before cycling is initiated, and to ensure ultrafiltrate does not progressively accumulate during cycling (Blake, 2014).

III. **APD WITH DAYTIME EXCHANGES.** Even APD with a day dwell does not provide adequate clearances for some patients once residual renal function is lost. Additional exchanges and day dwells may be required. These dwells improve clearance as the typical 14- to 16-hour, single

day dwell in APD does not provide significant additional clearance after the first 4–6 hours. These additional day exchanges also improve ultrafiltration as the single day dwell is often too long for effective net fluid removal. In fact, in many patients, especially higher transporters, a single dextrose day dwell can result in significant net fluid resorption. Additional day exchanges can be done manually using standard CAPD transfer sets, but this is relatively expensive in terms of solution and tubing costs, and may be inconvenient for patients.

An alternative strategy involves using the cycler tubing to deliver the additional exchange(s). The patient returns to the cycler in the afternoon or evening, reattaches to the transfer set, drains the dialysate that has been in the peritoneal cavity since that morning, and then refills from the large-volume solution bags (3–5 L) that will be used to provide solution for cycling that night. The patient then detaches from the transfer set but is able to reattach to the same tubing later to commence cycling that night. This is made possible by a modification of the transfer set that allows serial connections and disconnections to be performed or by simply using “caps” to protect the respective endings of the transfer set and adapter tubing while disconnected. This strategy, which has been described as using the cycler as a “docking station,” can be easily performed with any of the newer generation of cyclers, and is less costly because no additional transfer set is required and because the solution can be drawn from more economical, large-volume solution bags. It has the additional advantage that it can be set up for the patient in advance by a relative or a helper. However, for the working patient, the requirement to return to the cycler during the noncycling period may be a disadvantage, and in such cases, a manual CAPD-type exchange may be preferred.

In some patients, a second day dwell is not required for clearance reasons but a single long day dwell leads to net fluid resorption. In these cases, the cycler tubing can be used to drain the day dwell early without any subsequent fill (Fig. 22.3). A common alternative strategy in this setting is to use icodextrin solution, which maintains an adequate oncotic gradient even during 16-hour day dwells.

References and Selected Readings

- Blake PG. Drain pain, overflow, and how they are connected. *Perit Dial Int*. 2014;34: 342–344.
- Brown EA, et al. Survival of functionally anuric patients on automated peritoneal dialysis: the European APD Outcome Study. *J Am Soc Nephrol*. 2003;14:2948–2957.
- Cho Y, et al. Impact of icodextrin on clinical outcomes in peritoneal dialysis: a systematic review of randomized controlled trials. *Nephrol Dial Transplant*. 2013;28: 1899–1907.
- Cho Y, et al. Biocompatible dialysis fluids for peritoneal dialysis. *Cochrane Database Syst Rev*. 2014;3:CD007554.
- Cizman B, et al. The occurrence of increased intraperitoneal volume events in automated peritoneal dialysis in the US: role of programming, patient user actions and ultrafiltration. *Perit Dial Int*. 2014;34:434–442.
- Davies SJ. Longitudinal membrane function in functionally anuric patients treated with automated peritoneal dialysis: data from EAPOS on the effects of glucose and icodextrin prescription. *Kidney Int*. 2005;67:1609–1615.
- Davies SJ. What has balANZ taught us about balancing ultrafiltration with membrane preservation? *Nephrol Dial Transplant*. 2013;28:1971–1974.

- Davies SJ, et al. Icodextrin improves the fluid status of peritoneal dialysis patients: results of a double-blind randomized controlled trial. *J Am Soc Nephrol*. 2003;14:2338–2344.
- Feriani M, et al. Individualized bicarbonate concentrations in the peritoneal dialysis fluid to optimize acid-base status in CAPD patients. *Nephrol Dial Transplant*. 2004;19:195–202.
- Johnson DW, et al. Effects of biocompatible versus standard fluid on peritoneal dialysis outcomes. *J Am Soc Nephrol*. 2012;23:1097–1107.
- Jones M, et al. Treatment of malnutrition with 1.1% amino acid peritoneal dialysis solution: results of a multicenter outpatient study. *Am J Kidney Dis*. 1998;32:761–767.
- Kiernan L, et al. Comparison of continuous ambulatory peritoneal dialysis-related infections with different “Y-tubing” exchange systems. *J Am Soc Nephrol*. 1995;5:1835–1838.
- Li PK, et al. Randomized, controlled trial of glucose-sparing peritoneal dialysis in diabetic patients. *J Am Soc Nephrol*. 2013;24:1889–1900.
- Li PK, et al. Comparison of double-bag and Y-set disconnect systems in continuous ambulatory peritoneal dialysis: a randomized prospective multicenter study. *Am J Kidney Dis*. 1999;33:535–540.
- Lo WK, et al. A 3-year, prospective, randomized, controlled study on amino acid dialysate in patients on CAPD. *Am J Kidney Dis*. 2003;42:173–183.
- Mistry CD, et al. A randomized multicenter clinical trial comparing isosmolar icodextrin with hyperosmolar glucose solutions in CAPD. *Kidney Int*. 1994;46:496–503.
- Rippe B, et al. Long-term clinical effects of a peritoneal dialysis fluid with less glucose degradation products. *Kidney Int*. 2001;59:348–357.
- Rodriguez AM, et al. Automated peritoneal dialysis: a Spanish multicentre study. *Nephrol Dial Transplant*. 1998;13:2335–2340.
- Tranaeus A; for Bicarbonate/Lactate Study Group. A long-term study of a bicarbonate/lactate-based peritoneal dialysis solution—clinical benefits. *Perit Dial Int*. 2000;20:516–523.
- Williams JD, et al. The Euro-Balance Trial: the effect of a new biocompatible peritoneal dialysis fluid (balance) on the peritoneal membrane. *Kidney Int*. 2004;66:408–418.

The success of peritoneal dialysis as renal replacement therapy hinges upon the patient possessing a functional peritoneal access. In the present era, access is obtained using a catheter device that bridges the abdominal wall and serves as a controlled cutaneoperitoneal fistula. Similar in principle to creation of an arteriovenous access for hemodialysis, provision of a peritoneal access must consider a number of patient factors that can influence flow function, durability, and resistance to complications.

I. **ACUTE AND CHRONIC CATHETERS.** Based on design and use, catheters can be classified as acute or chronic.

A. **Acute catheters**

1. **Rigid noncuffed catheters.** Composed of relatively rigid plastic, these noncuffed tubes are provided in straight and slightly curved configurations with numerous side holes in the intraperitoneal segment. Insertion is performed by percutaneous puncture using an internal stylet. Because of the risk of infection, the generally accepted period of maximum use is 3 days. If a short course of peritoneal dialysis is anticipated or therapy must be initiated before a chronic catheter can be placed, the temporary rigid catheter remains an option. These devices are available in kits containing the catheter, connecting tubing, and a scalpel.
2. **Soft cuffed catheters.** Most of the chronic catheters described more fully in the following section can serve as acute peritoneal access devices and are generally available in self-contained sets, permitting bedside placement using a percutaneous needle-guidewire approach to insert a peel-away catheter introducer sheath. If it is anticipated that the need for peritoneal dialysis will be longer than a few days, a chronic catheter should be placed initially, whenever possible. While the trend for chronic catheters is to use two-cuff devices, one of the continuing demands for a single-cuff catheter is to provide acute access. Compared to the rigid catheter, the one-cuff soft tube can be left in place indefinitely, and it is easier to insert and remove than two-cuff chronic devices. If long-term dialysis is likely and the patient's clinical condition permits, consideration should be given to implanting a chronic catheter with at least two cuffs.

B. **Chronic catheters.** Presently, all chronic catheters are constructed of silicone rubber, a material well recognized for its biocompatibility and biodurability. A small percentage of

catheters were previously constructed from polyurethane rubber, but these have not been commercially available since 2010. Although the number of surviving polyurethane devices is rapidly diminishing, it is important to identify these catheters because of the tendency of polyurethane rubber to develop stress fractures or to soften and rupture from chronic exposure to polyethylene glycol or ethanol present in certain topical antibiotic ointments and creams commonly used for chronic catheter exit-site prophylaxis. Polyurethane catheters can be recognized by a permanently bonded catheter adapter and they typically show permanent dark discoloration of the tubing after several years.

Figure 23.1 depicts a chronic peritoneal catheter showing its relationship to abdominal wall structures. Chronic catheters are most commonly supplied with two Dacron (polyester) cuffs, but as many as three cuffs may be present in extended two-piece catheters. Having at least two cuffs provides for better immobilization of the catheter in the abdominal wall. The deep cuff is preferably implanted in the muscle to provide for firm tissue ingrowth and fixation of the catheter. The superficial cuff is positioned in the subcutaneous tissues 2–4 cm from the exit site. When properly positioned, the superficial cuff serves as an effective barrier to entry of cutaneous debris and bacteria into the subcutaneous track and acts to limit the piston-like motion of the catheter in and out through the exit site that can drive these contaminants into the track.

The intraperitoneal segment of the catheter tubing has either a coiled-tip or straight-tip configuration with an end hole and numerous side holes. No significant difference in functionality has been demonstrated between coiled- and straight-tip catheters; however, previous randomized comparative studies involved small subject numbers with equivocal results, and the validity of a recent meta-analysis favoring straight-tip catheters is debatable. The incidence of inflow discomfort is greater with straight-tip catheters due to the jet effect of the dialysate from the end hole of the catheter. Coiled-tip catheters provide for better dispersion of the dialysate during inflow.

All recently manufactured chronic catheters incorporate a white radiopaque stripe along the longitudinal axis of the tubing which enables radiographic visualization. The stripe can also serve as a guide during implantation of the catheter to prevent accidental twisting or kinking of the catheter tubing. The majority of adult catheters have a 2.6-mm internal bore. One catheter brand possesses a 3.5-mm bore and can be identified by its blue radiopaque stripe. While in vitro flow rates of the larger bore catheter are faster, this has not been so apparent in the in vivo state. The importance of recognizing the catheter bore size is to prevent inadvertent interchange of replacement catheter adapters that can result in a loose fit and accidental separation.

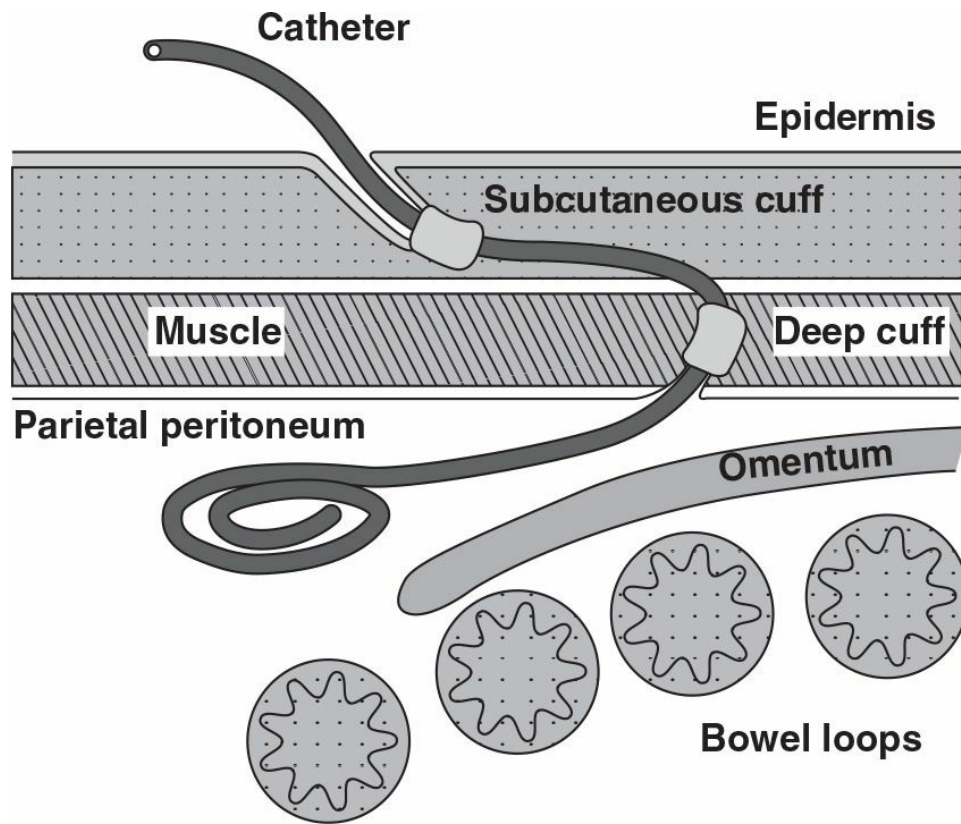

FIGURE 23.1 Schematic of a coiled-tip Tenckhoff peritoneal catheter showing its proper relationship to adjacent anatomical structures.

1. **Standard abdominal catheters.** The coiled- and straight-tip Tenckhoff catheters and their “swan neck” variants with a preformed arc bend in the intercuff segment are illustrated in Figure 23.2A,B. These four catheters comprise the mainstay of peritoneal access around the world. The primary difference among these catheters is that the coiled-tip configuration and preformed arc increase the cost of the device. Standard abdominal catheters can be inserted by any of the implantation methodologies.
2. **Extended two-piece catheters.** Originally designed as a presternal catheter, the extended catheter comprises a one-cuff abdominal catheter segment that attaches to a subcutaneous extension segment having one or two cuffs by using a titanium connector to permit remote location of the exit site to the upper chest (Fig. 23.2C). It has since been used to provide remote locations of exit sites to the upper abdomen or the back region. The abdominal catheter can be placed by any insertion method. The subcutaneous extension catheter is implanted using a vascular tunneling rod or a similar device supplied by the catheter manufacturer.
3. **Alternative catheter designs.** Modifications of the basic Tenckhoff catheter design have been made to address problems with tissue attachment, tip migration, and pericatheter leaks. The Oreopoulos–Zellerman (Toronto Western) variation of the straight-tip catheter includes the addition of two silicone disks to the end of the tubing in an attempt to hold bowel and omentum away from the side holes (Fig. 23.2D). The Di Paolo catheter is designed to discourage catheter tip migration by adding a tungsten weight to the end of the tubing to promote gravitational self-location to the pelvis (Fig. 23.2E). The Oreopoulos–Zellerman and Missouri catheters have a Dacron flange adjacent to a

silicone bead mounted below and contiguous with the deep cuff (Fig. 23.2F). The flange and bead are attached at a 45-degree angle on the Missouri version. Suturing the peritoneum between the flange and bead and stitching the flange to the posterior rectus sheath were designed to reduce the occurrence of pericatheter leaks. Mounting the flange and bead at a 45-degree angle was intended to keep the catheter tip oriented toward the pelvis. None of the alternative configurations have been shown to outperform the standard Tenckhoff catheter design, but do increase the cost and difficulty of device insertion.

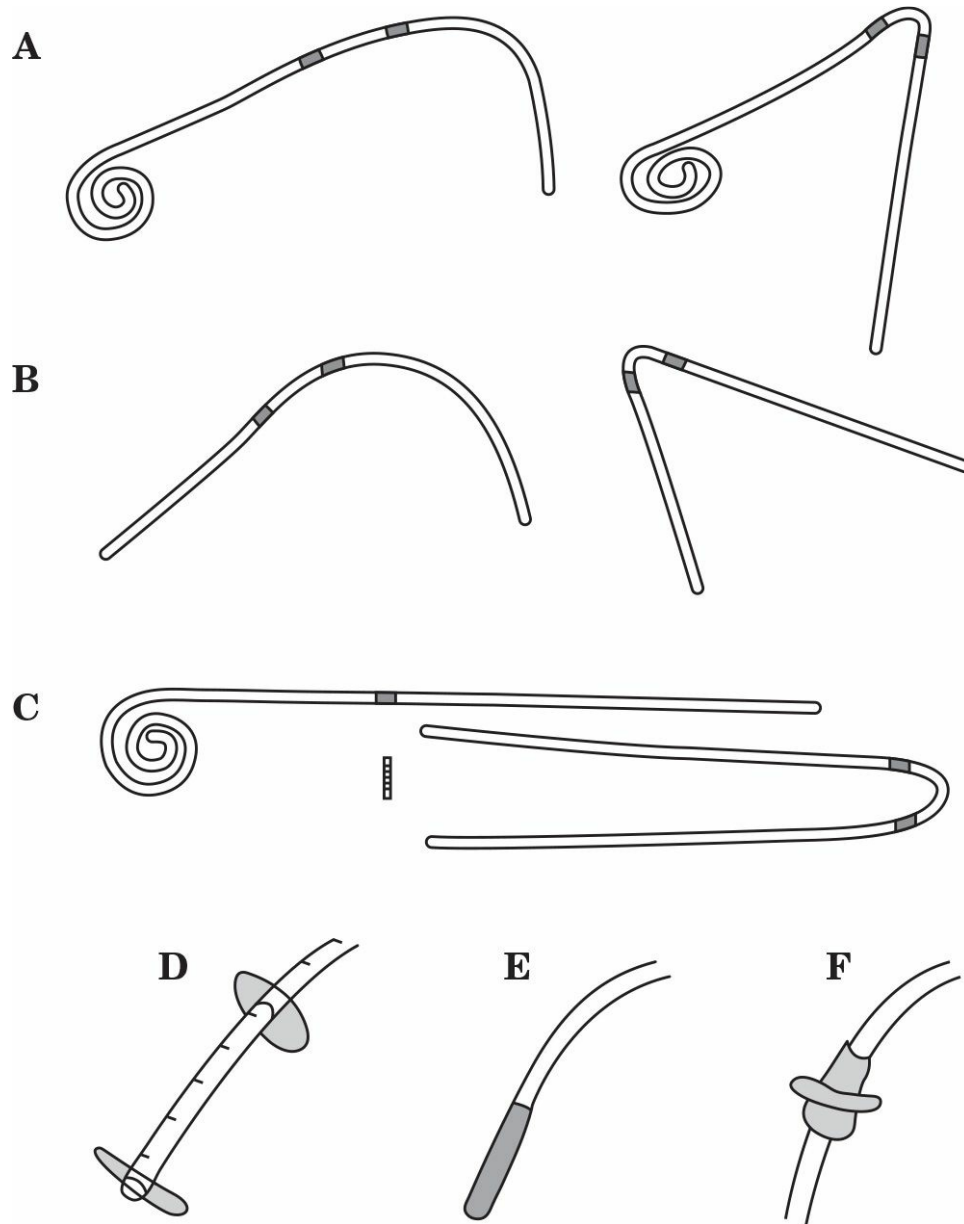

FIGURE 23.2 Shown are commonly used peritoneal catheters and alternative design features. **A:** Tenckhoff catheters with coiled-tip, two-cuff, and straight or swan neck intercuff segment. **B:** Tenckhoff catheters with straight-tip, two-cuff, and straight or swan neck intercuff segment. **C:** Extended catheter with coiled-tip, one-cuff abdominal catheter, two-cuff extension catheter with swan neck intercuff segment, and titanium connector. **D:** Straight-tip catheter with silicone disks. **E:** Straight-tip catheter with tungsten weight. **F:** Dacron flange and silicone bead below and adjoining the deep cuff.

II. CATHETER SELECTION

- A. **Patient factors influencing catheter selection.** Patients come in all sizes and shapes with a variety of medical conditions; therefore, it is somewhat naive to expect that one catheter type should fit all. Choice of catheter type should take into consideration the patient's belt line, obesity, skin creases and folds, presence of scars, chronic skin conditions, incontinence, physical limitations, bathing habits, and occupation. A basic inventory of several catheter types is required to provide customization of the peritoneal access to the specific needs of the patient and to afford maximum flexibility in exit-site location. Figure 23.3 illustrates how a basic catheter inventory might be applied. Patients who wear their belt lines above the umbilicus are often best served with a catheter with a swan neck bend that allows the exit site to emerge below the belt line. Patients who wear their belt lines below the umbilicus are usually best fitted with a catheter having a straight intercuff segment that is bent to produce a laterally directed exit site emerging above the belt line. Individuals who have large rotund abdomens, severe obesity, drooping skin folds, intestinal stomas, feeding tubes, urinary or fecal incontinence, yeast intertrigo, or desire to take deep tub baths are ideal candidates for extended catheters to produce upper abdominal or presternal exit sites.
- B. **Stencil-based preoperative mapping.** Some dialysis catheter manufacturers produce marking stencils for the most commonly used catheter designs. Properly constructed stencils contain critical catheter design information, including the distance between the deep cuff and the coil, suggested subcutaneous tunnel configurations, and recommended exit-site locations relative to the position of the superficial cuff. Additional features of a well-designed stencil plate permit its precise orientation on the trunk region according to fixed anatomical landmarks, such as the pubic symphysis (representing the anterior upper border of the true pelvis) and the anatomical midline of the torso. Stencils permit accurate and reproducible association of the catheter design elements to these anatomical landmarks to help determine the best catheter style and insertion site that will produce optimal pelvic position of the catheter coil and ideal exit-site location.

Figure 23.4 shows the use of the stencil for lower abdominal, upper abdominal, and chest catheter exit-site locations. The stencil should be initially used during a preoperative evaluation where the patient can be examined fully clothed and in supine, sitting, and/or standing positions. The stencil can also be used at the time of the catheter insertion procedure to mark and/or verify the markings made during the preoperative examination. During the preoperative mapping session in which the most appropriate catheter style is selected, only the exit-site cutouts need to be marked. At the time of the procedure, the entire pattern including incision marks, tunnel track, cuff and exit-site cutouts are marked.

During the preoperative examination, the stencil is used to mark the exit sites of the standard abdominal catheters while the patient is supine. The patient then assumes a sitting or standing position, and the marked exit sites are checked to see which is best visible to the patient and does not conflict with the belt line, skin creases, or apices of bulging skin folds. If none of the marked exit sites for the standard abdominal catheters are satisfactory, the stencil is then used to map out either upper abdominal or presternal exit-site locations. Be aware that some manufacturers produce impractical stencils that show only the cutout pattern of a swan neck bend but do not allow for proper alignment of the stencil plate on

the abdominal or chest wall.

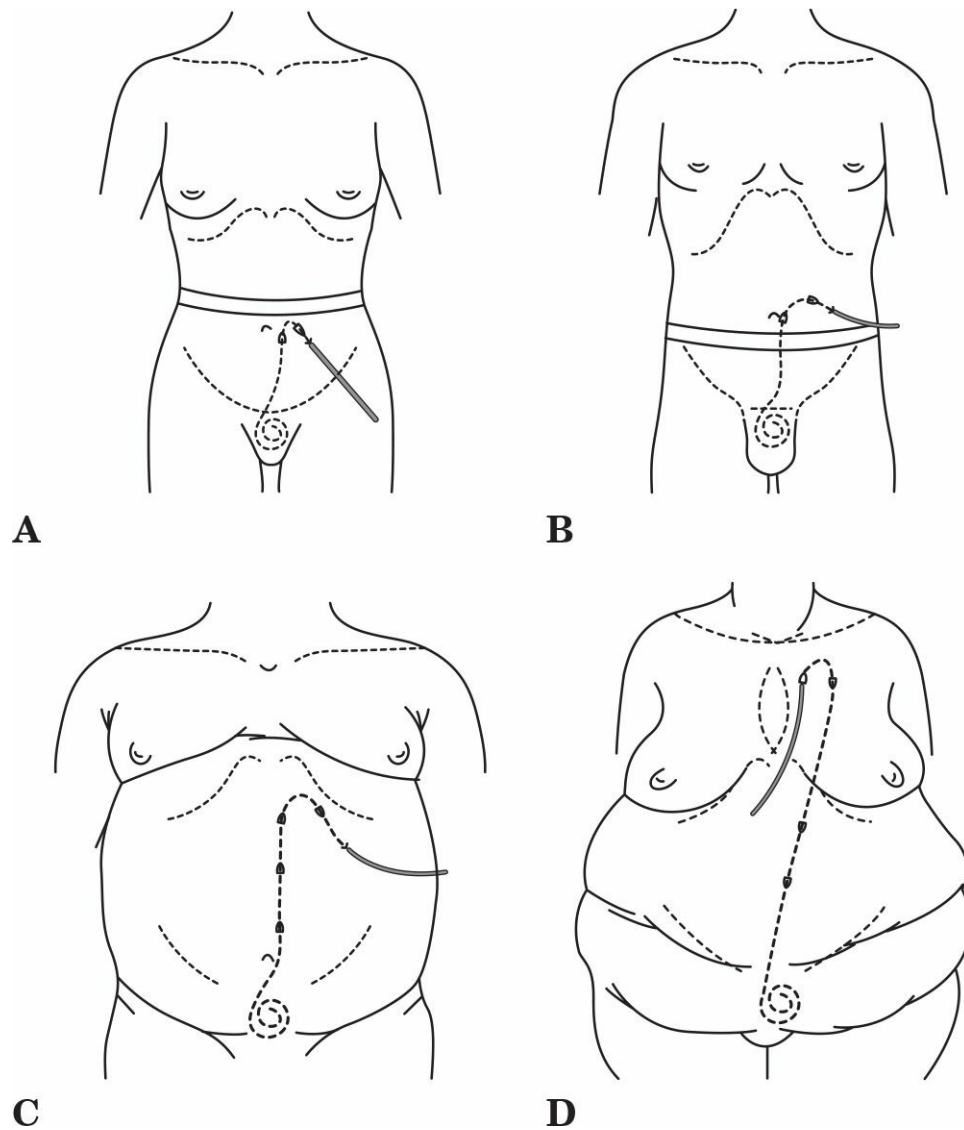

FIGURE 23.3 Practical applications of a basic catheter inventory. **A:** Swan neck catheter with downwardly directed exit site emerging below a high-lying belt line. **B:** Straight intercuff segment catheter with laterally directed exit site emerging above a low-lying belt line. **C:** Extended catheter with upper abdominal exit site for an obese rotund abdomen, lower abdominal skin folds, or incontinence. **D:** Extended catheter with upper chest exit site for severe obesity, multiple abdominal skin folds, intestinal stomas, or incontinence.

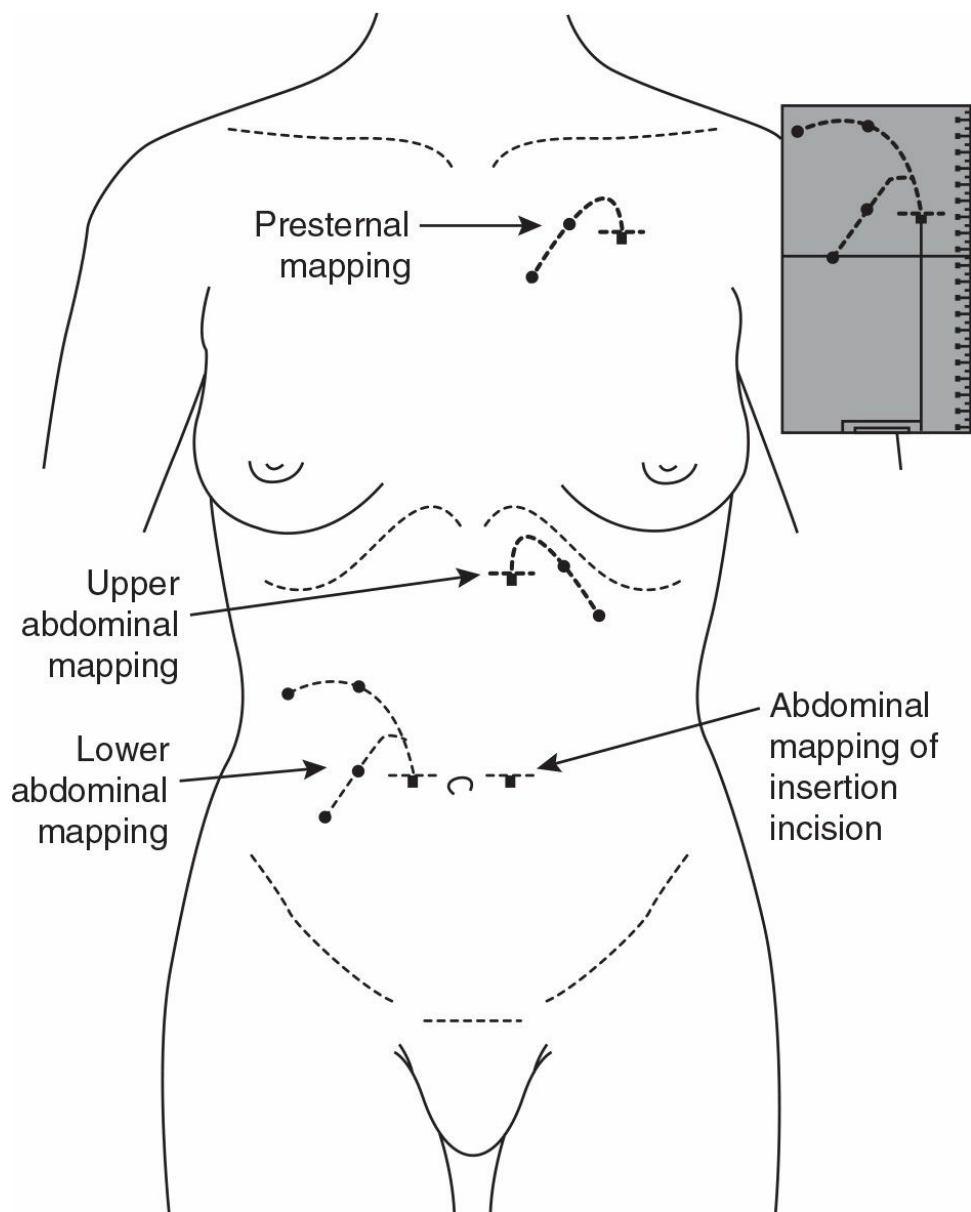

FIGURE 23.4 Stencil-based preoperative mapping for standard abdominal and extended catheters. This allows for selection of the most appropriate device type and insertion site that will produce the best pelvic position of the catheter tip and the optimal exit-site location, based on patient-specific anatomical features.

III. CATHETER PLACEMENT PROCEDURES

- A. **Best practices.** A best practice is a technique or methodology that, through experience and research, has proven to reliably lead to a desired result. Best practices for preoperative preparation and peritoneal catheter placement are listed in Tables 23.1 and 23.2. Adherence to a constellation of details is required to assure the best opportunity for creating a successful long-term peritoneal access. Omission of any one of these best practices can lead to loss of the peritoneal catheter. It is recognized that some implantation techniques do not incorporate all of the best practices, such as percutaneous needle-guidewire approaches performed through the midline or positioning the deep cuff above the level of the fascia. It is enough that the practitioner be aware of the deviations from recommended practice and be observant of the potential complications that may arise from such departures. In addition, some of the listed best practices will not be applicable to

acute noncuffed temporary catheters.

TABLE

23.1

Best Practices in Patient Preparation for PD Catheter Insertion

- Preoperative assessment to select the most appropriate catheter type and exit-site location
- Bowel prep the day before surgery: 2 L of polyethylene glycol solution, enema, or stimulant suppository
- Shower on the day of surgery with chlorhexidine soap wash of the abdomen/chest
- Removal of body hair in the preoperative holding area, preferably with electric clippers
- Empty the bladder before procedure; otherwise, Foley catheter should be inserted
- Single preoperative dose of prophylactic antibiotic to provide antistaphylococcal coverage

TABLE

23.2

Best Practices for PD Catheter Insertion

- Operative personnel are attired in cap, mask, and sterile gown and gloves
- Surgical site is prepped with chlorhexidine–gluconate scrub, povidone–iodine (gel or scrub), or other suitable antiseptic agent and sterile drapes applied around the surgical field
- Peritoneal catheter is rinsed and flushed with saline and air squeezed out of the Dacron cuffs by rolling the submerged cuffs between fingers
- Paramedian insertion of the catheter through the body of the rectus muscle
- Deep catheter cuff positioned within or below the rectus muscle
- Pelvic location of the catheter tip
- Catheter flow test performed to confirm acceptable function
- Skin exit site directed lateral or downward (not upward)
- Subcutaneous tunneling instrument should not exceed the diameter of the catheter
- Exit site should be smallest skin hole possible that allows passage of the catheter
- Position subcutaneous cuff 2–4 cm from the exit site
- No catheter anchoring sutures at the exit site
- Attach transfer (extension) set at time of procedure
- Exit site protected and catheter immobilized by nonocclusive dressing

B. **Acute noncuffed catheter insertion.** The semirigid acute catheter is inserted by percutaneous puncture using an internal stylet. A 1-cm midline or paramedian skin incision is made approximately 2.5 cm below the level of the umbilicus. A hemostat clamp is used to spread down to the fascia. The stylet is inserted into the catheter until the pointed tip is exposed. Depth of penetration is controlled by grasping the catheter–stylet assembly with the thumb and index finger. With the patient tensing the abdominal musculature, the catheter–stylet assembly is advanced through the musculofascial layer with a twisting motion under

constant controlled pressure until a “pop” or sudden drop in resistance is sensed, indicating entry into the peritoneal cavity. The patient is allowed to relax the abdominal muscles. Holding the catheter in place, the stylet is immediately withdrawn several centimeters to “hide” the pointed end. Gently, the catheter is advanced toward the pelvis without moving the stylet until satisfactory depth has been achieved. The stylet is removed, and the administration set is attached to the catheter. A suture or catheter holder is used to secure the temporary catheter. Alternatively, the abdomen may be prefilled with 1–2 L of dialysis solution before inserting the catheter–stylet. A Veress needle (a Veress needle is a spring-loaded needle used to create pneumoperitoneum for laparoscopic surgery) or a 16G–18G intravenous cannula is inserted into the peritoneal cavity through the incision described earlier to perform the prefill.

C. **Chronic catheter placement.** Methods for insertion of chronic peritoneal catheters include placement by percutaneous guidewire technique (performed blindly or with image guidance), the YTEC laparoscopic-assisted approach, open surgical dissection, and laparoscopic implantation. Optionally, the implantation technique may include extending the catheter to a remote exit-site location and/or embedding the external limb of the catheter tubing under the skin with delayed externalization when initiation of dialysis is needed. An overview of each of the implantation approaches will be presented.

1. **Percutaneous needle–guidewire technique.** Placement of catheters by blind percutaneous puncture is performed using a modification of the Seldinger technique. The convenience of this approach is that it can be performed at the bedside under local anesthesia using prepackaged self-contained kits that include the dialysis catheter. The abdomen is prefilled with 1.5–2 L dialysis solution instilled with an 18G introducer needle inserted through a 1.5- to 2-cm infraumbilical or paramedian incision. Alternatively, a Veress needle may be used to perform the prefill. A guidewire is passed through the needle into the peritoneal cavity and directed toward the retrovesical space. The needle is withdrawn. A dilator with overlying peel-away sheath is advanced through the fascia over the guidewire. The guidewire and dilator are removed. Stiffened over a stylet, the dialysis catheter is directed through the sheath toward the pelvis. As the deep catheter cuff advances, the sheath is peeled away. The deep cuff is advanced to the level of the fascia.

The addition of fluoroscopy to the procedure permits confirmation of needle entry into the peritoneal cavity by observing the flow of injected contrast solution around loops of bowel. The retrovesical space is identified by contrast pooling in the appropriate location. The guidewire and catheter are advanced to this site. Ultrasonography can be used in a similar fashion. The remainder of the procedure is as described for blind placement. Although the radiopaque tubing stripe permits fluoroscopic imaging of the final catheter configuration, the proximity of adhesions or omentum cannot be assessed. Percutaneous guidewire placement techniques usually leave the deep catheter cuff external to the fascia. After testing flow function, the catheter is then tunneled subcutaneously to the selected exit site.

2. **YTEC procedure.** The YTEC procedure is a proprietary laparoscopic-assisted technique of peritoneal catheter placement. A 2.5-mm trocar with an overlying plastic sleeve is

inserted percutaneously into the peritoneal cavity through a paramedian incision. The obturator of the trocar is removed, permitting insertion of a 2.2-mm laparoscope to confirm peritoneal entry. The scope is withdrawn and 0.6–1.5 L of room air is pumped into the abdomen with a syringe or hand bulb. The scope is reinserted and the overlying cannula and plastic sleeve are visually directed into an identified clear area within the peritoneal cavity. The scope and cannula are withdrawn, leaving the expandable plastic sleeve to serve as a conduit for blind insertion of the catheter over a stylet into the identified clear area. The plastic sleeve is withdrawn and the deep cuff is pushed into the rectus sheath. After testing flow function, the catheter is tunneled subcutaneously to the selected exit site.

3. **Open surgical dissection.** A paramedian incision is made through the skin, subcutaneous tissues, and anterior rectus sheath. The underlying muscle fibers are split to expose the posterior rectus sheath. A small hole is made through the posterior sheath and peritoneum to enter the peritoneal cavity. A purse-string suture is placed around the opening. The catheter, usually straightened over an internal stylet, is advanced through the peritoneal incision toward the pelvis. Despite being an open procedure, the catheter is advanced mostly by feel, therefore, blindly, into the peritoneal cavity. The stylet is partially withdrawn as the catheter is advanced until the deep cuff abuts the posterior fascia. After satisfactory placement has been achieved, the stylet is completely withdrawn and the purse-string suture is tied. Encouraging the catheter tip to remain oriented toward the pelvis is achieved by oblique passage of the catheter through the rectus sheath in a craniocaudal direction. The catheter tubing is exited through the anterior rectus sheath at least 2.5 cm cranial to the level of the purse-string suture and deep cuff location. Attention to detail in placement of the purse-string suture and repair of the anterior fascia is imperative to prevent pericatheter leak and hernia. The catheter is tunneled subcutaneously to the selected exit site following a satisfactory test of flow function.
4. **Laparoscopic.** Laparoscopy provides a minimally invasive approach with complete visualization of the peritoneal cavity during the catheter implantation procedure. The advantage of laparoscopic catheter placement over other approaches is the ability to proactively employ adjunctive procedures that significantly improve catheter outcomes. Laparoscopically guided rectus sheath tunneling places the catheter in a long musculofascial tunnel oriented toward the pelvis and eliminates catheter tip migration. Observed redundant omentum that lies in juxtaposition to the catheter tip can be displaced from the pelvis into the upper abdomen and fixed to the abdominal wall (omentopexy). Compartmentalizing adhesions that may affect completeness of dialysate drainage can be divided. Intraperitoneal structures that siphon up to the catheter tip during the intraoperative irrigation test can be laparoscopically resected, including epiploic appendices of the sigmoid colon and uterine tubes. Previously unsuspected abdominal wall hernias can be identified and repaired at the time of the catheter implantation procedure.

Through a lateral abdominal wall puncture site remote from the point of intended catheter placement, the abdomen is insufflated with gas through a Veress needle to

create an intraperitoneal working space. A laparoscopic port and laparoscope are inserted. Under laparoscopic guidance, the catheter is introduced at a second puncture site and placed in a musculofascial tunnel oriented toward the peritoneum, usually through the use of a port device that creates the rectus sheath tunnel. Some variations of the technique use a third laparoscopic port site to introduce laparoscopic forceps to assist in the catheter tunneling process. The catheter tip is directed into the true pelvis under visual control. The deep cuff of the catheter is positioned in the rectus muscle just below the anterior fascial sheath. A purse-string fascial suture is placed around the catheter at the level of the anterior sheath to minimize the risk of pericatheter leak. The laparoscope is left in place until a test irrigation of the catheter demonstrates successful flow function. After any indicated adjunctive procedures are completed, the catheter is tunneled subcutaneously to the selected exit site.

5. Special access procedures

- a. **Extended catheters.** The abdominal segment of two-piece extended catheters can be implanted by any of the aforementioned insertion techniques. A secondary incision is made in the vicinity of the planned upper abdominal, presternal, or back exit site. A marking stencil is invaluable in devising the location of the secondary incision and exit site. The measured distance between the abdominal insertion incision and the secondary incision is used to calculate how much tubing length will be trimmed from one or both of the catheter segments in order to correctly span the distance. The trimmed catheters are joined with a titanium connector, and the linked catheter segments are tunneled on the surface of the fascia from the abdominal insertion site to the remote secondary incision with a tunneling rod. The extension catheter is then passed from the secondary incision through the exit site using a stylet to complete the procedure.
- b. **Catheter embedding procedure.** Catheter embedding has been characterized as the “AV fistula of peritoneal dialysis.” The catheter is implanted in advance of intended use and allowed to “mature” in the subcutaneous bed until the start of dialysis (Fig. 23.5). The catheter is allowed to heal in the sterile environment of the subcutaneous space without the potential contamination from the presence of an exit wound. Firm tissue ingrowth into the cuffs and absence of biofilm formation have been speculated to reduce catheter infection-related peritonitis. Another important attribute of catheter embedding is greater patient acceptance for earlier commitment to peritoneal dialysis by catheter placement ahead of time. The patient is not burdened with catheter maintenance until dialysis is needed. The need for insertion of vascular catheters and temporary hemodialysis can be averted in patients previously implanted with an embedded catheter. When needed, the catheter is simply exteriorized and the patient begins dialysis with full volumes, avoiding the need for a break-in period. The embedding technique permits more efficient surgical scheduling of catheter implantation as a nonurgent procedure and helps to reduce stress on operating room access. Disadvantages of the catheter embedding strategy include the need for two procedures (implantation and exteriorization) as opposed to one and the possibility of futile placement in the

event of a change in the patient's condition.

Catheter embedding can be incorporated into any of the implantation approaches using any catheter device. The catheter is temporarily externalized through the future skin exit site prior to embedment. The exit-site scar serves as a landmark to know where to come back to for externalization. After acceptable flow function of the catheter is confirmed, the tubing is flushed with heparin, plugged, and buried in the subcutaneous tissue. To minimize the risk of hematoma or seroma and to facilitate subsequent externalization, the catheter should be embedded in a linear or curvilinear subcutaneous track using a tunneling stylet as opposed to curling the tubing into a subcutaneous pocket. Embedding should not be performed if anticipated need for dialysis is <4 weeks. Externalization of embedded catheters is an office procedure. Catheters have been embedded for months to years, with an 85%–93% immediate function rate upon externalization. Overall, 94%–99% are successfully used for dialysis after radiologic or laparoscopic revision of nonfunctioning catheters.

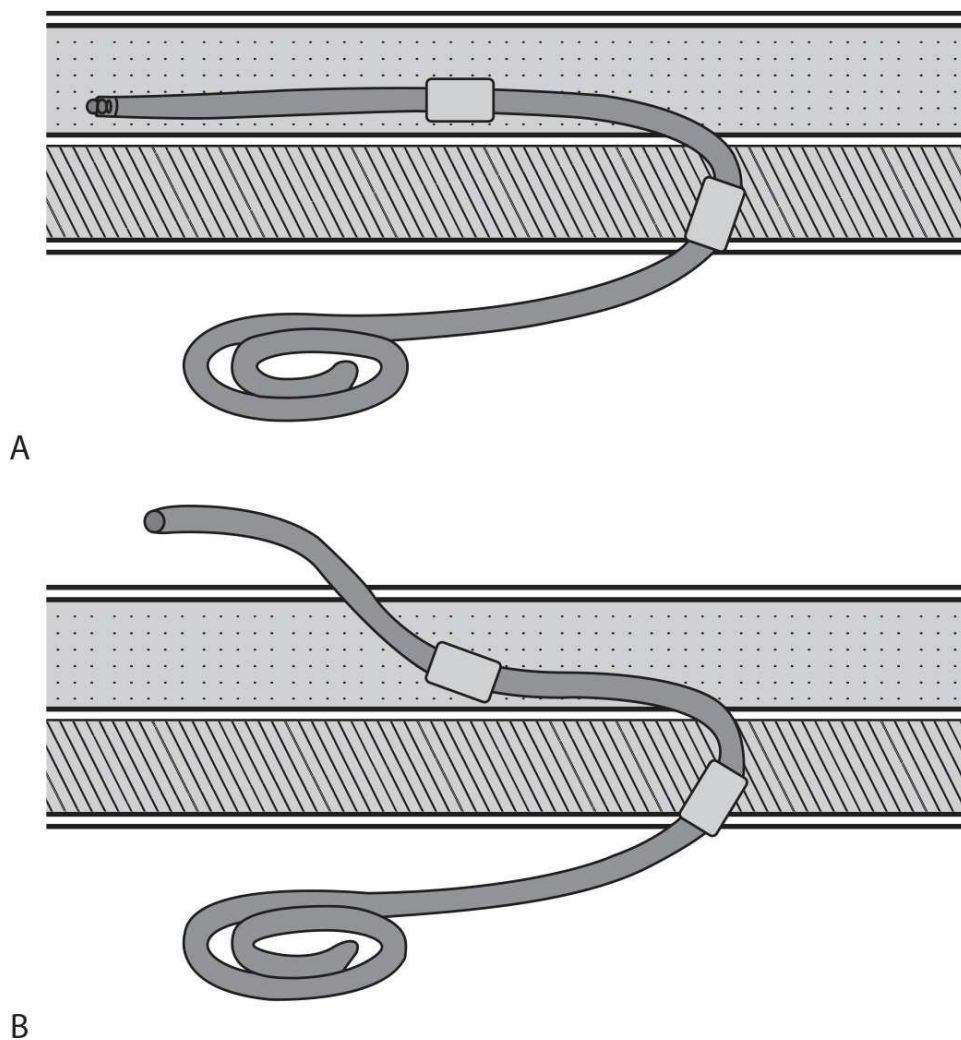

FIGURE 23.5 Illustrated is the embedded catheter strategy. **A:** External limb of the catheter tubing is embedded under the skin at the time of catheter placement. **B:** External limb of the catheter is externalized when the time to initiate dialysis has arrived.

IV. CATHETER BREAK-IN PROCEDURES

- A. **Acute catheters.** There is no specific strategy to break-in acute catheters. As they are to be used acutely, there often are few options. Some have suggested an incremental approach to increasing the peritoneal volume.
- B. **Chronic catheters.** There is no particular evidence-based approach for initiating patients onto peritoneal dialysis. The following are some considerations:
 1. **Catheter irrigation.** Performance of postoperative irrigation (flushing) when immediate use of the catheter is not anticipated is covered in Section VII.A.
 2. **Chronic nonurgent start.** When possible, exchanges should be delayed for 2 or more weeks after catheter insertion to allow for healing and prevent leakage. Either chronic ambulatory peritoneal dialysis or automated peritoneal dialysis can be initiated at that time. The size of the dwell volume can be increased over the course of the training period. For patients treated with automated peritoneal dialysis, leaving the patient with no last fill for a number of weeks may help reduce the risk of leaks. While the catheter is healing, it is suggested that the patient limit his or her physical activities for 4–6 weeks, especially activities that could increase intra-abdominal pressure.
 3. **Chronic urgent start.** A growing body of literature suggests that starting patients immediately (<2 weeks after catheter insertion) on peritoneal dialysis is feasible. In some studies, the leak rate does not appear to be significantly higher than nonurgent starts. Furthermore, an urgent start on peritoneal dialysis provides an alternative to those patients who would otherwise initiate therapy on hemodialysis with a central venous catheter. Surgically implanted catheters can be used immediately postinsertion, provided that a tight seal is created at the peritoneum to prevent leaks. Percutaneously inserted catheters can also be used immediately; however, because of the increased risk of leak, the feasibility of this strategy should be assessed according to the historical experience of the center.

No standard dialysis prescription exists for patients starting peritoneal dialysis urgently; however, most have described an incremental approach. Such an approach might consist of initiating exchanges with approximately 1 L volumes and increasing the amount by 250–500 mL per week. Commencing therapy with the patient in the supine position will minimize the risks of dialysate leaks from increased intra-abdominal pressure. It has been demonstrated that when surgically placed catheters are appropriately secured, full-volume exchanges can be started immediately. As with chronic catheters, patients should be advised to reduce physical activity for about 4–6 weeks after insertion to allow for proper healing.

V. ACUTE COMPLICATIONS OF CATHETERS

- A. **Preperitoneal placement.** During insertion of acute noncuffed catheters, if the stylet of the catheter fails to enter the peritoneal cavity, the semirigid catheter may be inadvertently advanced into the preperitoneal space. Similarly, unintended preperitoneal position of the introducer needle or Veress needle can occur during chronic catheter placement using percutaneous needle–guidewire approaches. Dialysis solution inflow will be slow and often painful. Outflow will be minimal, and the effluent may become blood-tinged. If this

occurs, drain as much fluid as possible, then remove the catheter and insert at another site.

- B. **Blood-tinged dialysis effluent.** In addition to preperitoneal catheter placement, blood-tinged outflow can result from injury of a blood vessel in the abdominal wall or mesentery. The return will usually clear with continued dialysis.
- C. **Serious complications.** Grossly bloody effluent, fall in hematocrit, or signs of shock signify large blood vessel injury. Urgent laparotomy is usually required. Unexplained polyuria and glycosuria suggest accidental puncture of the urinary bladder. If the needle has entered the bowel, instillation of dialysate will be accompanied by pain and/or an urgent need to defecate. In case of suspected bowel entry with a small-bore acute catheter or needle, it is sometimes possible to merely remove the catheter or needle and observe the patient carefully while treating with intravenous antibiotics. Catheter insertion should be delayed a few days until it is certain that there are no complications as a result of penetrating the bowel. Unrecognized bowel entry may be heralded by feces or gas in the effluent or watery diarrhea having high glucose content. Surgical intervention is often required, and appropriate consultation should be obtained. If surgical exploration is planned, it is helpful to leave the catheter in place so that the site of perforation can be more easily identified.

VI. COMPLICATIONS OF CHRONIC PERITONEAL CATHETERS. Mechanical and infectious complications are the two most common reasons for interruption of dialysis therapy and loss of the peritoneal catheter. Early and appropriate interventions can allow successful resumption of dialysis, avoid removal of the catheter, or, in the event of catheter loss, minimize the time before return to peritoneal dialysis.

- A. **Mechanical complications.** Mechanical complications of the catheter include pericatheter leaks, infusion and drain pain, outflow failure, and catheter tip migration.
 - 1. **Pericatheter leak.** This complication is usually related to catheter implantation technique, timing of initiation of dialysis, and strength of abdominal wall tissues. When dialysis is initiated, subcutaneous leakage may occur at the catheter insertion site and usually manifests itself as fluid appearing through the incision or at the exit site. Questionable leaks can be verified by a positive glucose dipstick indicating high glucose concentration of the seeping fluid. Delaying initiation of dialysis for 10–14 days following catheter placement minimizes the risk for developing a leak. Temporarily discontinuing dialysis for 1–3 weeks usually results in spontaneous cessation of an early leak. Dramatic early leaks may indicate purse-string suture failure or technical error in wound repair and demands immediate exploration. Leakage through the exit site or insertion incision leaves the patient prone to tunnel infection and peritonitis. Prophylactic antibiotic therapy should be employed. Persistent leaks warrant catheter replacement.

Late pericatheter leaks are caused by pericannular hernia or occult tunnel infections, with separation of the cuffs from the surrounding tissues. The occurrence of pericannular hernia is largely influenced by the location and degree of fixation of the deep cuff. At the parietal peritoneal surface, the mesothelium reflects along the surface of the catheter to reach the deep cuff. If the deep cuff was placed outside of the muscle wall or the cuff shifts outward because of weak midline fascial attachments, then the

peritoneal lining actually extends above the fascial layer, creating the potential for a pseudohernia and pericatheter leak. If the abdominal wall is weak, the track may dilate and develop a true hernia. Most late leaks and pericatheter hernias are best managed by catheter replacement.

2. **Infusion pain.** Pain during dialysate infusion is usually observed in new patients initiating dialysis and is often transient in nature, spontaneously disappearing over several weeks. Persistent infusion pain is commonly associated with the acidity (pH 5.2–5.5) of conventional lactate-buffered dialysis solutions. Use of bicarbonate/lactate-buffered dialysis solutions (pH 7.0–7.4) can eliminate this pain. If buffered solutions are not available, manual addition of bicarbonate to each dialysis bag (4–5 mmol/L) is required to treat acid-related infusion pain. Alternatively, a 1% or 2% lidocaine solution added to the dialysate (5 mL/L) may be tried to assuage infusion discomfort.

Other causes of dialysate-related pain include hypertonic glucose solutions, aged dialysis solution, overdistention of the abdomen, or extremes in dialysate temperature. Compared to coiled dialysis catheters, straight-tip catheters appear to be associated with a higher incidence of mechanical inflow pain caused by the jet effect of the dialysate from the end hole of the tubing. Catheter malposition with the tip against the abdominal wall or tube restriction by attached tissues can produce both inflow and outflow pain. Slower infusion rates and incomplete drainage may diminish these symptoms; however, transluminal catheter manipulation or laparoscopic exploration should be considered for flow pain that is persistent or accompanied with hydraulic dysfunction with or without associated catheter malposition.

3. **Drain pain.** Pain during outflow is common, especially toward the end of the drain, and is especially frequent in the early days after initiation of dialysis. As the intraperitoneal structures siphon up to the catheter tip during the drain, it causes the catheter to bump up against the exquisitely sensitive parietal peritoneum. The pain is frequently experienced in the genital or anorectal region. Drain pain is more frequently a problem with automated peritoneal dialysis due to hydraulic suction on the peritoneal lining. Catheters implanted too low on the abdominal wall can wedge tubing into the deep pelvis, resulting in drain pain from early closure of pelvic viscera around the catheter tip. Similarly, constipation with crowding of the bowel around the catheter in the pelvis can cause or contribute to the severity of the symptoms. The drain pain sometimes resolves with time or with treatment of associated constipation. If persistent, it can be managed by avoiding complete drainage of the peritoneal effluent. In cycler patients, this can be achieved by performing some degree of tidal peritoneal dialysis. In resistant cases of drain pain, repositioning of the catheter may be attempted, but even this does not always resolve the problem.
4. **Outflow failure.** Catheter flow dysfunction is usually manifested as outflow failure; therefore, the volume of drained dialysate is substantially less than the inflow volume, and there is no evidence of pericatheter leakage. Outflow failure usually occurs soon after catheter placement, but it may also commence during or after an episode of peritonitis, or at any time during the life of the catheter. Evaluation and treatment for the common causes of flow dysfunction are as follows:

- a. **Constipation and urinary retention.** The most common cause of outflow dysfunction is constipation. Distended rectosigmoid colon may block the catheter side holes or displace the catheter tip into a position of poor drainage function. Extrinsic bladder compression on the catheter due to urinary retention occurs less frequently. Abdominal radiography is helpful to look for a fecal-filled colon and catheter displacement. Constipation is treated with oral administration of an emollient, such as 70% sorbitol solution, 30 mL every 2 hours until the desired effect is achieved. Polyethylene glycol solution, 2 L, ingested over a period of 4–6 hours is usually effective in persistent cases. Stimulant laxatives such as bisacodyl and saline enemas are reserved for refractory cases since chemical and mechanical irritation of the colonic mucosa have been associated with transmural migration of bacteria and development of peritonitis.
- b. **Tubing kink.** Mechanical kinking of the catheter tubing is usually accompanied by two-way obstruction. A flat-plate radiograph of the abdomen is often helpful in identifying a kink in the catheter tubing. Catheter revision or replacement will be required.
- c. **Fibrin strands and plugs.** Heparin should be added to the dialysate whenever fibrin strands or plugs are visible in the effluent. Heparin is more useful prophylactically than therapeutically, preventing the formation of fibrin clots and extension of existing clots. Once outflow obstruction has occurred, irrigation of the catheter with heparin is usually unsuccessful in recovering function.

If flow function is not restored with heparin, then thrombolytic therapy with tissue plasminogen activator (tPA) may be attempted. Failure to dislodge intraluminal debris by brisk irrigation of the catheter with saline is followed by instillation of tPA using the protocol described in Table 23.3. If catheter obstruction is due to a fibrin clot, recovery of flow function with tPA has been reported at nearly 100%. Because of cost considerations, the dose of tPA (used in a dilution of 1 mg/mL) has been based on the calculated volume of the catheter assembly; however, no adverse consequences have been documented for catheter overflow or repeated administration.

- d. **Catheter manipulation for outflow failure.** If treatment of constipation and fibrinolytic therapy are not successful in restoring drainage function, and if urinary retention and tubing kinks have been excluded, the catheter is presumed to be obstructed by omentum or other adherent intraperitoneal structures. Interventions to resolve catheter obstruction are now most commonly performed using radiologic and laparoscopic techniques.
 1. **Radiologic intervention.** Fluoroscopic guidewire manipulation has been used to redirect displaced and obstructed catheters. Stiff guidewire manipulation of catheters with a swan neck bend can be difficult. Forceful straightening of the subcutaneous tunnel can produce tunnel track trauma and infection. Transluminal manipulation is not practical for extended catheters because of the long tubing length.

A preprocedure dose of prophylactic antibiotics to provide antistaphylococcal coverage is advisable. Particular attention must be given to antiseptic preparation of the catheter tubing in addition to creating a sterile surgical field for the procedure. The transfer set is disconnected and discarded. After catheter manipulation is performed, restoration of flow function is checked by syringe irrigation. Frequently, multiple, separate manipulation procedures are required, with long-term flow function restored in only 45%–73% of cases. Failure rates for fluoroscopic manipulation as high as 90% were observed when patients had an antecedent history of abdominopelvic surgery or peritonitis, suggesting that adhesions play a major factor in technical failures.

TABLE

23.3

Tissue Plasminogen Activator Protocol for Thrombolysis of Obstructed Peritoneal Dialysis Catheters

Total Volume of Catheter and Transfer Set Assembly

Adult Catheter Size		Catheter Volume (mL) ^a	Total Volume with Baxter Transfer Set (mL) ^b	Total Volume with Fresenius Extension Set (mL) ^b
Internal Diameter (cm)	Length (cm)			
0.26 ^c	42	2.2	4.2	4.7
0.26 ^c	57	3.0	5.0	5.5
0.26 ^c	62	3.3	5.3	5.8
0.35 ^d	62	6.0	8.0	8.5

Protocol:

1. Aspirate contents of catheter to remove any povidone-iodine from transfer set
2. Slowly but steadily instill 110% calculated volume of tPA (1 mg/mL) into catheter
3. Allow tPA to remain in catheter for 60 minutes
4. Aspirate tPA from catheter
5. With 60-mL syringe, briskly irrigate the catheter with saline to determine patency and to dislodge any fibrin clots
6. Repeat process if catheter remains obstructed

^aVolume = $\pi r^2 h$; $\pi = 3.14$, r = radius of catheter bore, h = height (length) of tube.

^bBaxter 6-in transfer set = 2 mL; Fresenius 12-in extension set = 2.5 mL.

^cInternal diameter of conventional Tenckhoff catheters.

^dInternal diameter of Flex-Neck catheter.

2. **Laparoscopic intervention.** Laparoscopy has become an invaluable method of evaluating and resolving catheter flow obstruction. Because laparoscopy can reliably identify the source of flow dysfunction and provide a means for definitive treatment, it is often considered as the next step in the management sequence after other causes for obstruction have been excluded. The dialysis catheter frequently can be used to perform the initial gas insufflation of the abdomen since most catheter obstructions represent outflow problems. Alternatively, a Veress needle is used for insufflation, or the initial laparoscopic port is placed by direct cutdown on the peritoneum. Laparoscopic exploration is performed to identify the source of obstruction.

Additional laparoscopic ports for introduction of operating instruments may be required depending on the findings.

Omental attachment to the catheter coil with displacement of the tubing out of the pelvis is a common cause of outflow dysfunction. Omental entrapment is relieved by using laparoscopic grasping forceps to strip the omentum from the catheter. The catheter tip is temporarily exteriorized through one of the port sites to facilitate removal of residual intraluminal tissue debris. The omentum is laparoscopically sutured to the upper abdominal region (omentopexy) to keep it away from the catheter. Redundant epiploic appendices of the sigmoid colon and uterine fimbria may siphon up to the catheter coil and produce obstruction. Laparoscopic resection of the involved epiploic appendices and uterine tube prevents recurrent obstruction.

Obstruction of the catheter by adhesive scar tissues can be treated by laparoscopically dividing the adhesions or simply pulling the catheter free of the adhesions if they are not too extensive. Adhesiolysis for poor drainage function, especially after peritonitis, is associated with a 30% failure rate secondary to re-forming of adhesions.

Catheter tip migration to a position of poor drainage function is frequently caused by shape-memory resiliency forces of a straight catheter bent into a configuration that imposes excessive stress on the tubing. Simply repositioning the catheter will be followed by recurrence of the migration in a high percentage of cases. Laparoscopic suturing of the catheter tip to a pelvic structure has an unacceptable rate of failure due to erosion of the suture. A more reliable approach is to laparoscopically place a suture sling in the suprapubic region through the abdominal wall and around the catheter. A sling will maintain the catheter toward the pelvis and not hinder catheter removal if required at a later date.

5. **Cuff extrusion through the exit site.** Erosion of the superficial cuff through the exit site can result from positioning the cuff too close (<2 cm) to the exit wound during catheter placement. In addition, excessive bending of the catheter with a straight intercuff segment to produce a downward exit direction can induce mechanical stresses on the tubing. In combination with close proximity of the cuff to the exit site, the shape-memory forces of a catheter bent into this configuration can lead to tube straightening over time with migration of the superficial cuff toward and through the exit site. Another cause for superficial cuff erosion that can eventually result in extrusion of the entire catheter is outer displacement of the tubing due to poor location and fixation of the deep cuff. Lastly, exit-site infection extending to the superficial cuff may cause it to separate from the surrounding tissues and extrude through the exit site.

An extruded cuff becomes a reservoir of bacteria within the vicinity of the exit wound. Exacerbated by daily wetting of the cuff during routine exit-site care, the presence of this infected sponge interferes with maintaining acceptable exit-site hygiene. Using a scalpel blade applied parallel to the cuff surface, the cuff can be shaved in repetitive slices until all of the cuff material is removed. The blade should be

changed often to assure ease in performing the shave without applying undue pressure on the tubing. Extra care should be taken when shaving the cuff from 3.5-mm internal bore catheters (identified by the blue radiopaque stripe), as this thin-walled tubing can be easily damaged. Alternatively, catheters with extruded cuffs can be managed by replacing the cuffed tubing segment by a splicing procedure, as described in the following section.

B. Catheter infection and management. Details of antibiotic treatment for catheter infections are discussed in Chapter 27. The eventual outcome of a chronic exit-site infection with superficial cuff involvement is a tunnel abscess or progression of the tunnel infection to the peritoneal cavity, producing concurrent peritonitis. Early recognition of chronic exit-site and tunnel infection is essential to provide the best opportunity for catheter salvage. Interventions for catheter infection are reviewed in what follows:

1. Exit-site and tunnel infection. Exit-site infection presents as redness, swelling, and tenderness at the exit site. With tunnel involvement, the signs of infection extend along the subcutaneous course of the catheter. In most cases, exit-site and tunnel infections are accompanied by purulent discharge from the exit site. In chronic smoldering cases, the exit-site skin is loose around the catheter, granulation tissue is present at the skin exit sinus, and purulent material can be expressed through the exit orifice with pressure over the subcutaneous cuff or stroking the skin over the tunnel toward the exit site while gently tugging on the catheter. As long as the infection has not extended to the deep cuff, it is possible to resolve the problem without losing the catheter or interrupting therapy. Ultrasonography of the catheter tunnel is a useful preoperative tool to evaluate for deep cuff involvement, particularly in obese patients where physical signs are often unreliable. Patients found to have infection involving the deep cuff on ultrasonography should undergo catheter removal. Moreover, patients with concurrent peritonitis are not candidates for catheter salvage procedures, as peritonitis suggests that transmural spread of the infection has already occurred.

a. Unroofing–cuff shaving. Unroofing the skin and subcutaneous tissue overlying the infected catheter tunnel permits drainage of pus, debridement of granulation tissue, and shaving of the superficial cuff. The catheter, including the shaved tubing segment, is directed out of the medial aspect of the incision and stabilized in this position by securing it to the adjacent skin with sterile adhesive strips. The wound is left open with performance of wet-to-dry dressing changes (once or twice daily) with saline-soaked gauze, and allowed to heal by secondary intention.

Depending on the magnitude of the infection, the procedure can be performed in the treatment room or operating room under local or general anesthesia. The primary advantage of the unroofing–cuff shaving procedure is that dialysis is not interrupted.

b. Catheter splicing. An alternative surgical treatment approach for chronic exit-site infection that has not extended beyond the superficial cuff is replacement of the infected external tubing segment by catheter splicing. This may be the preferred salvage procedure for a badly chosen exit-site location that was placed in an infection-prone area, such as within a skin crease, on the apex of a flabby skin

fold, or under the belt line. In this circumstance, performing only an unroofing–cuff shaving procedure may still result in an exit-site location that is predisposed to infection. The spliced catheter segment can be routed to a more stable exit-site location including the upper abdomen or chest region. Since the procedure requires more extensive dissection and tunneling, it is best performed in the operating room under local or general anesthesia.

After skin preparation, the infected exit-site is isolated from the primary surgical field during draping and managed in the final step to prevent contamination of the new catheter and wound. An incision is made through the previous insertion site scar to expose the uninvolved intercuff segment of the catheter at the level of the fascia. The catheter is divided in the intercuff segment to preserve a 2.5-cm stump on the deep cuff side. A single- or double-cuff catheter with or without a preformed swan neck bend may be selected for the splicing segment. After trimming the new catheter to appropriate length, the segment is joined to the stump of the deep cuff end of the original catheter with a titanium connector. The external segment of the spliced catheter is tunneled to a suitable exit location remote from the infected exit site. The wound is closed and dressings are applied. In the final step, the external part of the old catheter is removed and the wound is debrided and packed open with saline wet-to-dry dressings. Antibiotics are continued for 2–4 weeks until the infected wound is healed. Peritoneal dialysis can be resumed immediately after the procedure.

2. **Catheter infection–related peritonitis.** Progression of an exit-site and tunnel infection to the deep cuff can lead to concurrent peritonitis. Rarely, peritonitis can lead to chronic deep cuff infection and proceed in a retrograde fashion to manifest initially as a tunnel infection. Ultrasonography can be helpful in evaluating deep cuff involvement. Catheter infection–related peritonitis is best managed by catheter removal. Antibiotic treatment for peritonitis is discussed in Chapter 27. Reinsertion of the dialysis catheter can be performed 4–6 weeks following completion of antibiotic therapy for peritonitis.

VII. CARE OF THE CHRONIC PERITONEAL CATHETER. Postoperative management of primarily externalized catheters will vary depending on whether they are used immediately or if a 2-week delay is to be prescribed to allow for wound healing and firm tissue ingrowth of the cuffs.

- A. **Catheter irrigation.** Catheters that are not used immediately should undergo irrigation with 1 L of solution (saline or dialysate) within 72 hours following insertion to wash out blood and fibrinous debris. If the effluent is particularly bloody, irrigation is repeated until signs of clearing are evident. To assure patency, it is a good idea to repeat the irrigation weekly until such time that dialysis is instituted. Heparin added to the irrigant (1,000 units/L) is helpful in preventing fibrin plugging of the catheter during the early postoperative period.
- B. **Postoperative catheter immobilization and dressings.** Since no catheter anchoring stitches are used, it is important to immobilize the catheter on the abdominal wall with medical adhesive and sterile adhesive strips. A nonocclusive barrier dressing of sufficient size to protect the exit-site and surgical wounds and to further immobilize the catheter should be applied at the time of the placement procedure. In addition, the transfer set should be secured to the

abdominal wall to prevent tugging on the catheter at the exit site. As long as the dressings are clean and intact and the exit site appears stable, dressings are changed on a weekly basis until such time that the patient is instructed in the protocol for chronic exit-site care. If, at any time, the exit site appears unstable, the frequency of exit-site care is modified according to the findings.

- C. **Long-term catheter and exit-site care.** Patients should limit themselves to nonstrenuous activities for 4–6 weeks following catheter placement to permit good wound healing. If exit-site healing is uneventful, most patients are able to resume showering in 3–4 weeks. This usually coincides with implementation of the chronic exit-site care routine. Most exit-site care protocols involve daily cleansing with nonirritating, nontoxic, antiseptic agents and application of a prophylactic antibiotic ointment or cream such as mupirocin or gentamicin. Sterile dressings over the exit site are encouraged. Tub bathing and swimming with immersion of the exit site are discouraged. Centers that permit swimming usually restrict the activity to properly chlorinated private pools or ocean water. It is recommended that an ostomy appliance or similar device cover the exit site and catheter during swimming and to perform routine exit-site care after the activity. Patients should be reminded that the catheter is a “lifeline” and advised to consider the consequences of risking exposure of their peritoneal access to potential contamination during swimming.
- D. **Embedded catheter care.** Patients who undergo catheter embedment may resume showering after 48 hours. Avoidance of strenuous activities is required for 4–6 weeks following catheter placement to permit good wound healing.

Externalization of embedded catheters is a clinic procedure performed using sterile technique in a suitable treatment room under local anesthesia. If appropriate embedding technique was performed, the catheter tubing should be easily palpable at the incision scar created during the procedure while the catheter was temporarily externalized at the future exit site. In equivocal cases, ultrasound examination can be employed to identify the catheter tubing at the correct distance from the superficial cuff. Care is exercised in anesthetizing the skin and making the incision to avoid damage to the catheter. Hemostat dissection is used to identify and deliver the catheter from the embedment track. The plugged end of the tubing is amputated, the catheter adapter is inserted, the transfer set is attached, and flow is tested. The catheter may require brisk irrigation with a 60-mL syringe and saline to dislodge fibrin clots. Unsatisfactory flow should be managed as described under Section VI.A. Exit-site care following externalization of embedded catheters is the same as that described for primarily externalized catheters.

VIII. CATHETER REMOVAL AND SECONDARY EMBEDDING

- A. **Removal of acute noncuffed catheters.** Because of the concerns for peritonitis, acute noncuffed catheters should be removed within 3 days. After the abdomen is drained and retaining sutures are removed, the catheter is gently withdrawn. It is recommended that the peritoneum be allowed to rest for a couple of days before inserting a new catheter. Insertion sites for replacement catheters should alternate between medial and lateral locations, allowing a distance of at least 2–3 cm from the previous site.
- B. **Removal of chronic catheters.** Since firm tissue ingrowth of the Dacron cuffs will have occurred

by 2–3 weeks, chronic catheters in place for a longer period will usually require removal by surgical dissection in the operating room or suitable procedure room, especially if the deep cuff was positioned in the muscle layer. Fascial defects will require suture repair to prevent an abdominal wall hernia.

- C. **Secondary embedding of chronic catheters.** On occasion, catheter removal is performed because patients regain sufficient renal function to discontinue dialysis, but recovery is not expected to be permanent. An alternative to removing the catheter is secondary embedding. The inconvenience and cost of catheter maintenance can be eliminated for the interim by secondary embedding while still preserving a readily available peritoneal access that can be immediately employed. This approach avoids complications of new catheter placement such as flow dysfunction and pericatheter leak, and also avoids the necessity of possible future central venous catheter placement for urgent hemodialysis.

The procedure performed is similar to catheter splicing except that the spliced external segment is embedded. After skin preparation, the existing exit site and catheter are isolated from the primary surgical field during draping and managed in the final step to prevent contamination of the spliced catheter and wounds. An incision is made through the previous insertion site scar to expose the intercuff segment of the catheter. The catheter is divided in the intercuff segment to preserve at least a 2.5-cm stump on the deep cuff side. A single- or double-cuff catheter with or without a preformed swan neck bend may be selected for the splicing segment. After trimming the new catheter to appropriate length, the segment is joined to the stump of the deep cuff end of the former catheter with a titanium connector. The external segment of the spliced catheter is temporarily externalized at the new exit site and then tunneled into a subcutaneous bed, as described in the section on embedded catheters. After the wounds are closed and protected, the remaining external segment of the former catheter is removed and the old exit-site wound is excised and closed.

Suggested Readings

- Attaluri V, et al. Advanced laparoscopic techniques significantly improve function of peritoneal dialysis catheters. *J Am Coll Surg*. 2010;211:699–704.
- Brown PA, et al. Complications and catheter survival with prolonged embedding of peritoneal dialysis catheters. *Nephrol Dial Transplant*. 2008;23:2299–2303.
- Brunier G, et al. A change to radiological peritoneal dialysis catheter insertion: three-month outcomes. *Perit Dial Int*. 2010;30:528–533.
- Crabtree JH. Rescue and salvage procedures for mechanical and infectious complications of peritoneal dialysis. *Int J Artif Organs*. 2006;29:67–84.
- Crabtree JH, Burchette RJ. Effective use of laparoscopy for long-term peritoneal dialysis access. *Am J Surg*. 2009;198:135–141.
- Crabtree JH, Burchette RJ. Comparative analysis of two-piece extended peritoneal dialysis catheters with remote exit-site locations and conventional abdominal catheters. *Perit Dial Int*. 2010;30:46–55.
- Crabtree JH, Burchette RJ. Peritoneal dialysis catheter embedment: surgical considerations, expectations, and complications. *Am J Surg*. 2013;206:464–471.

- Flanigan M, Gokal R. Peritoneal catheters and exit-site practices toward optimum peritoneal access: a review of current developments. *Perit Dial Int*. 2005;25:132–139.
- Gadallah MF, et al. Peritoneoscopic versus surgical placement of peritoneal dialysis catheters: a prospective randomized study on outcome. *Am J Kidney Dis*. 1999;33:118–122.
- Ghaffari A. Urgent-start peritoneal dialysis: a quality improvement report. *Am J Kidney Dis*. 2012;59:400–408.
- Gokal R, et al. Peritoneal catheters and exit-site practices toward optimum peritoneal access: 1998 update. *Perit Dial Int*. 1998;18:11–33.
- Hagen SM, et al. A systematic review and meta-analysis of the influence of peritoneal dialysis catheter type on complication rate and catheter survival. *Kidney Int*. 2014;85:920–932.
- McCormick BB, et al. Use of the embedded peritoneal dialysis catheter: experience and results from a North American center. *Kidney Int*. 2006;70:538–543.
- Miller M, et al. Fluoroscopic manipulation of peritoneal dialysis catheters: outcomes and factors associated with successful manipulation. *Clin J Am Soc Nephrol*. 2012;7:795–800.
- Penner T, Crabtree JH. Peritoneal dialysis catheters with back exit sites. *Perit Dial Int*. 2013;33:93–96.
- Simons ME, et al. Fluoroscopically-guided manipulation of malfunctioning peritoneal dialysis catheters. *Perit Dial Int*. 1999;19:544–549.
- Twardowski ZJ, et al. Six-year experience with swan neck presternal peritoneal dialysis catheter. *Perit Dial Int*. 1998;18:598–602.
- Vaux EC, et al. Percutaneous fluoroscopically guided placement of peritoneal dialysis catheters—a 10-year experience. *Semin Dial*. 2008;21:459–465.
- Xie J, et al. Coiled versus straight peritoneal dialysis catheters: a randomized controlled trial and meta-analysis. *Am J Kidney Dis*. 2011;58:946–955.

Web References

- PD catheter placement using ultrasound and fluoroscopic guidance. <http://www.homebybaxter.com/how/home-therapies-institute/webinars-on-demand/pd-catheter-placement-ultrasound.html>
- Percutaneous insertion of peritoneal dialysis catheters with radiological guidance (buried & not buried). <http://ukidney.com/nephrology-videos/item/170-video-percutaneous-insertion-of-pd-catheter>
- Peritoneal dialysis access—catheters and placement. <http://www.homebybaxter.com/how/home-therapies-institute/webinars-on-demand/peritoneal-dialysis-access-catheters.html>
- Peritoneal dialysis catheter insertion at the bedside. <http://ukidney.com/nephrology-videos/item/1214-peritoneal-dialysis-catheter-insertion-at-the-bedside>

Peritoneal dialysis (PD) was the first successfully used modality of renal replacement therapy in acute kidney injury (AKI) patients. However, its use progressively declined after 1970 due to the greater convenience of acute hemodialysis, and it is now predominantly practiced in developing countries because of its lower cost and minimal infrastructure requirements. Recently, however, interest in using PD to manage selected AKI patients has been increasing (Ghaffari, 2013b), and a meta-analysis suggests outcomes equivalent to those with HD (Chionh, 2010).

I. INDICATIONS

A. **Advantages.** PD offers several advantages over hemodialysis in AKI. It is technically simple, with minimal infrastructure requirements and often lower cost. It may be the better option for the patient with difficult vascular access. Solute and water removal is gradual, with less potential for the development of disequilibrium syndrome, cardiovascular stress, and abrupt reductions in blood pressure. These potential benefits may, in turn, reduce the risk of renal and cardiac ischemia, fluid and electrolyte imbalance, and intracranial fluid shifts. No extracorporeal circulation is required, thus reducing the potential proinflammatory changes that can occur with the exposure of blood to synthetic tubing and membranes. Taken together, these factors could potentially be beneficial in permitting more rapid recovery of renal function.

Besides the classical indications (volume overload, electrolyte disorders, uremic symptoms, or acid–base disturbances), acute PD can also be used to maintain volume control in patients with congestive heart failure (CHF) functional class IV, to control hyper- or hypothermia, and to treat necrotizing pancreatitis with peritoneal lavage. Acute PD is increasingly being used in cases of advanced chronic kidney disease (CKD) presenting urgently with uremia or fluid overload, a scenario described as “urgent start PD.”

In the setting of natural disasters such as earthquakes, when several victims will develop AKI and when damage to infrastructure make access to power, clean water, and facilities for water treatment challenging, PD can be an important and life-saving renal replacement modality. Table 24.1 outlines the advantages and disadvantages of PD to treat patients with AKI.

B. **Limitations.** PD is relatively contraindicated in patients with recent abdominal

surgery, large abdominal hernias, adynamic ileus, intra-abdominal adhesions, peritoneal fibrosis, or peritonitis. Since volume and solute removal are slow and at times unpredictable, PD is not as safe and efficient as extracorporeal blood purification techniques for the treatment of certain emergencies, such as acute pulmonary edema, life-threatening hyperkalemia, and drug overdoses. The ability of PD to achieve adequate doses in hypercatabolic AKI has been a subject of controversy. Some authors have expressed concern over PD adequacy in these situations (Phu, 2002). However, there are also reports of positive outcomes associated with PD in hypercatabolic AKI patients, especially when intensive PD regimens were used (Chitalia, 2002; Ponce, 2012b).

PD increases intra-abdominal pressure, which may lead to impaired diaphragm mobilization, decreasing pulmonary compliance and ventilation, and this may cause or worsen respiratory failure. However, patients on PD generally maintain their vital capacity and respiratory volume, and PD is seldom the cause of ventilation impairment in patients without pulmonary disease. Another possible limitation of PD in AKI is that associated protein losses may aggravate malnutrition. Protein supplementation, either enteral or parenteral (1.5 g/kg per day) has been recommended for AKI patients on PD.

TABLE

24.1

Advantages and Disadvantages of Peritoneal Dialysis in Acute Kidney Injury

Advantages

- Simple to initiate
- Can be initiated anywhere
- No need for highly skilled personnel
- No need for vascular access
- No need for expensive equipment
- No exposure of blood to plastic
- No need for anticoagulation
- Minimum blood loss
- Possible less negative impact on recovery of renal function
- May be of special benefit in selected patients (children, or patients with heart failure, hemodynamic instability, bleeding diathesis)
- Is a form of continuous renal replacement therapy

Disadvantages

- Needs an intact peritoneal cavity with adequate peritoneal clearance capacity
- Adequacy may be of concern in hypercatabolic patients
- May not be adequate for patients with severe acute pulmonary edema or life-threatening hyperkalemia
- Ultrafiltration and clearance cannot be exactly predicted
- Infection (peritonitis) can occur
- The standard buffer used is lactate
- Concern about protein losses
- Can aggravate hyperglycemia
- Can impair respiratory mechanics

The high glucose concentrations in peritoneal dialysate may cause hyperglycemia, even in nondiabetic patients. This is easily correctable through intravenous, subcutaneous, or intraperitoneal administration of insulin. Peritonitis is a potential problem. Older studies reported a high frequency of peritonitis. However, with better catheter implantation techniques, improved connectology, and automated methods, the incidence has been reduced and the risk is similar to the incidence of infections with extracorporeal blood

II. TECHNICAL ASPECTS

A. **Peritoneal access.** Safe and efficient access to the peritoneal cavity is a crucial factor for PD success. For many years, bedside insertion of a rigid catheter using a trocar was the standard technique to access the peritoneal cavity for acute PD. This technique is still used routinely in many parts of the world, but its use has declined with the introduction of simple procedures for insertion of a flexible, cuffed Tenckhoff catheter, which provides the optimal access for PD. Depending on availability, a single- or double-cuff Tenckhoff catheter—either straight or swan neck—can be used in AKI. The advantages of a Tenckhoff catheter over the rigid catheter include having a lower incidence of leakage, larger-diameter lumen, and side holes resulting in better dialysate flow rates, and less obstruction as well as a decreased incidence of peritonitis. Furthermore, the rigid catheters need to be removed after 3–5 days, while the flexible, cuffed catheters can be left in indefinitely. Thus, if the patient does not recover renal function, the catheter may be used for chronic dialysis. Of course, it may be necessary to use alternative catheters with a rigid stylet, or even improvised options such as nasogastric tubes or surgical drains, in resource-poor environments where flexible, cuffed catheters are not available or are too costly.

Tenckhoff catheters can be inserted under local anaesthesia at the bedside, in a designated treatment room, or in a surgical theater. In a patient with previous abdominal surgery, laparoscopic or open technique is preferred, and this will usually require an operating room and a surgeon. In patients without previous surgery, no method of insertion is proven to be superior to any other. Rather, the method of implantation should be based on local availability of skills, equipment, and consumables. The bedside insertion utilizes a modified Seldinger approach with a guidewire and “peel-away” sheath and is a method practised by many nephrologists. The catheter is inserted as a blind procedure and therefore this method should be avoided, if possible, in those patients who have a midline surgical scar or history to suggest intra-abdominal adhesions. For details of catheter insertion methods see chapter 23.

B. **PD solutions.** Commercially prepared PD solutions are optimal because they have the advantage of minimizing the risks of errors in mixing fluids and of contamination, and of incorporating standardized and generally accepted connectology. Where these are not available because of logistical problems or costs, locally mixed fluids can be used, but sterile production and mixing of solutions as well as use of sterile connection devices are imperative. Such locally made PD fluids can be produced from physiological intravenous fluids by adding glucose and bicarbonate.

The composition of standard PD solutions is shown in Table 22.1. Other commercial intravenous solutions that can relatively easily be converted into dialysis fluids include Ringer’s lactate, Hartmann’s solutions, half normal saline, and Plasmalyte B. Standard PD solutions generally use lactate as a buffer; this is converted to bicarbonate mainly through liver and muscle pyruvate dehydrogenase enzymes. In critically ill AKI patients (such as those with shock, poor tissue perfusion states, liver failure, etc.), there may be impaired conversion of lactate to bicarbonate, which can aggravate metabolic acidosis. In such

patients, bicarbonate-containing PD solutions may be preferable. However, one small study randomized 20 AKI patients to treatment with either lactate- or bicarbonate-based PD and showed that while bicarbonate PD solution allowed better correction of metabolic acidosis and was associated with better hemodynamic stability, there were no differences in patient outcomes when compared to standard lactate solution (Thongboonkerd, 2001).

- C. **PD modalities.** The process of dialysate instillation and removal can be automated with a PD cycler. The advantage of this system is that it can be set up by a trained staff member to reduce the risk of complications. It reduces nursing time as all cycles are automatic, and there is some suggestion that peritonitis is less likely. Automated cyclers have been used extensively to perform PD in AKI, particularly when high-volume peritoneal dialysis (HVPD) is used. However, in a resource-poor setting, cyclers may be unavailable or too expensive.

The choice of the type of PD to be utilized should be based on the experience of the medical and nursing team, available resources, the safety and efficacy of the technique, and the needs of the individual patient. An illustration of various techniques applicable to AKI is provided in Figure 24.1 and Table 24.2.

1. **Intermittent PD (IPD).** This is the PD technique that historically has been most frequently used in AKI and it is still the most common, being routinely practiced in many parts of the world. Patients are treated for 48–72 hours, or occasionally longer, with rapid installation and drainage of fluid and a dwell time of 30–60 minutes. A trocar-style PD catheter is traditionally used and removed after the dialysis treatment is completed, but Tenckhoff catheters are a better option and are increasingly available. Since the dialysis is interrupted when the catheter is removed, the weekly small-solute clearance is limited and might be inadequate in hypercatabolic, critically ill AKI patients. There are no recent large studies addressing this issue. Modeling suggests that IPD can deliver appropriate amounts of dialysis in a fairly broad range of clinical circumstances, depending on the degree of residual renal function (Guest, 2012).

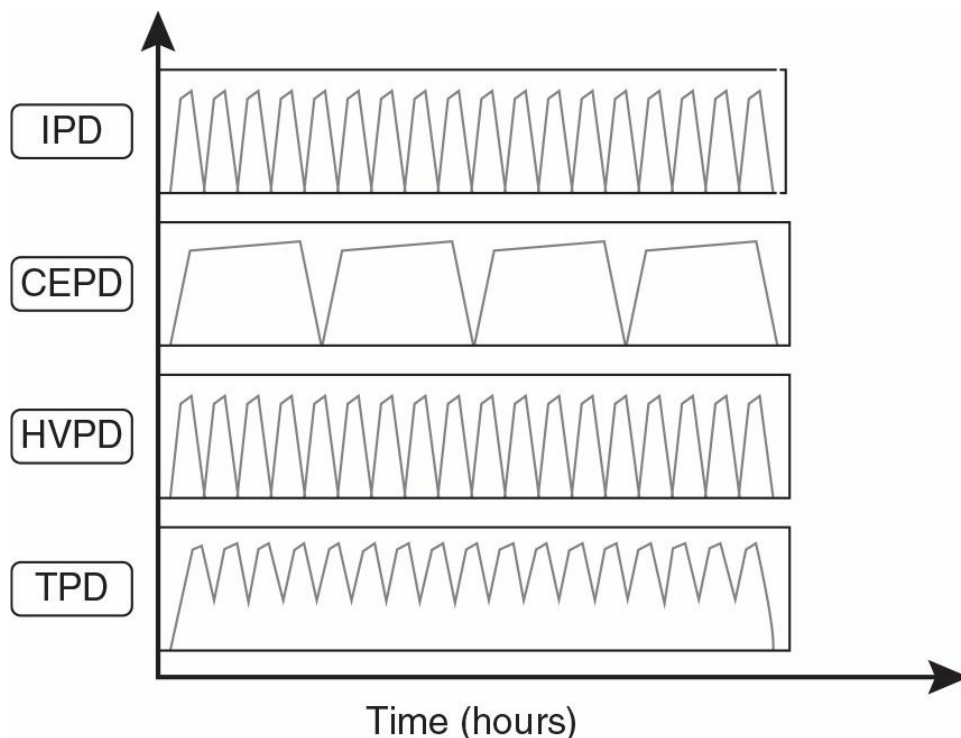

FIGURE 24.1 Illustration of the techniques of PD used for AKI patients. IPD, Intermittent PD; CEPD continuous equilibrated PD; HVPD, high volume PD; TDP, tidal PD.

TABLE

24.2

Different Types of Peritoneal Dialysis and Selected Features

PD Types	Urea Clearance (mL/min)	Dwell Time (min)	Volume/ Cycle	Total Volume (L)	Session Duration (hr)	Sessions per Week	Weekly <i>Kt/V</i>
IPD	12–20	30–60	2 L	30–48	24	2–5	—
CEPD	10–15	180–300	2 L	8–16	24	7	1.8–2.1
TIDAL	10–15	10–30	2 L fill	12–30	18–24	7/ duration	Variable cycle volume
HVPD	15–20	35–60	2 L	36–44	24	7	3.5–3.8

2. **Continuous equilibrated PD (CEPD).** This type of PD is similar to CAPD. A dwell time from 2 to 6 hours is typical, and the CEPD can be performed manually or with a cycler. Several reports of limited number of patients successfully treated by this method can be found from the 1980s onward. The clearance of small molecules and fluid removal with this methodology depend on the frequency and volume of exchanges and need to be determined based on the clinical status of the patient.
3. **Tidal PD (TPD).** TPD is performed with a dedicated cycler. In TPD, an initial large infusion of PD solution is followed by drainage of a portion of the dwell volume, typically 50%–75% of the initial volume, which is then replaced with fresh solution, restoring the initial intraperitoneal volume at each cycle. TPD may result in higher small-MW-solute clearances than CEPD, though not all studies have found this. TPD also may reduce the frequency of pain on drainage of dialysate from the abdomen.
4. **High-volume PD (HVPD).** HVPD is a continuous modality designed to achieve high small-MW-solute clearances. It requires an automated cycler and a Tenckhoff catheter. Each day the total PD solution delivered ranges from 36 to 44 L with a 30- to 50-minute dwell time. The efficacy of HVPD has been tested in several prospective studies involving seriously ill AKI patients in Brazil. With HVPD, a weekly *Kt/V* of 3.8 ± 0.6 could be delivered, and the mortality rate was around similar to that in AKI patients treated with intermittent or extended daily hemodialysis (Gabriel, 2008).

III. **PRESCRIBING AND DOSING OF ACUTE PD.** The most appropriate prescription and dose for PD in the management of patients with AKI is poorly defined because there are only a limited number of trials available to compare treatment modalities, the studies that have been done have methodological flaws, and the dose of dialysis used has varied widely (Chionh, 2010).

Where resources permit and where a cuffed catheter can be placed, using HVPD targeting a *Kt/V* urea of 0.5 daily (3.5 weekly) is associated with outcomes comparable to that of daily HD; targeting higher doses does not appear to improve outcome (Gabriel, 2008). A review of the literature suggests that such a high dose may not be necessary for many patients with AKI and that targeting a daily *Kt/V* of 0.3 (2.1 weekly) with a modified CEPD approach may be adequate

for many patients (Cionh, 2010; Ivarsen, 2013). This may be particularly helpful in developing countries where resources are limited, costs are critical, and AKI is more often caused by infections, volume contraction, obstetrical problem, and so on, rather than complex postsurgical complications with multiorgan failure.

During the initial 24 hours of therapy, the cycler dwell time needs to be dictated by the clinical circumstances of the patient. Short cycle times (every 1–2 hours) with dwell volumes of 1.5 or 2 L may be necessary to correct hyperkalemia, fluid overload, or metabolic acidosis. Thereafter, the cycle time can be increased but generally not beyond 4–6 hours. Ultrafiltration is regulated by adjusting the dextrose concentration of the solution and by shortening the cycler dwell time.

A. **How to prescribe acute PD.** As the dialysis requirements of a patient may change from day to day, it is prudent to write PD orders for only 24 hours at a time, reassessing and altering the prescription as indicated. A standardized form for acute PD prescriptions is helpful in assuring that the specifications of the procedure are complete and clear for the nursing staff responsible for its delivery (Table 24.3).

1. **Exchange volume.** Choice of exchange volume is dictated primarily by the size of the peritoneal cavity. An average-sized adult can usually tolerate 2-L exchanges, but in smaller patients, those with pulmonary disease, and those with abdominal wall or inguinal hernias, the volume should be reduced. Although initiating acute PD with a 2-L exchange volume is standard, some nephrologists prefer to start with smaller volumes (1–1.5 L) for the first few exchanges to minimize the risk of leaks. Otherwise, one should not reduce the exchange volume without good reason as this leads to lower clearances. In large or very catabolic patients, an exchange volume of 2.5–3 L may be helpful to augment the efficiency of dialysis.

TABLE

24.3

Acute Peritoneal Dialysis Sample Orders

A. Nursing orders

1. Dialysis to run _____ hours
2. Exchange volume: _____ L
3. Warm dialysis fluid to 37°C
4. Exchange time: Inflow 10 minutes
Dwell _____ minutes
Outflow 20 minutes or as long as fluid drains freely
DO NOT LEAVE FLUID IN ABDOMEN
5. Strict intake and output to be kept on fluid intake–output record
6. Dialysate balance to be recorded on peritoneal dialysis record
7. Dialysis fluid running balance to be maintained at: _____ L
8. Dialysate solution: _____ %
9. Additives to dialysate:
Medication dose frequency

_____/2 L q exchange **or** × _____ exchanges
_____/2 L q exchange **or** × _____ exchanges

10. Heparin: 1,000 units/2 L q exchange: yes/no
11. Turn and position patient p.r.n. for optimum outflow
12. Vital signs q _____ hours
13. Catheter care and dressing change every day
14. Withdraw 15 mL dialysis fluid from catheter port every morning during dialysis and send for cell count with differential, and culture and sensitivity: yes/no

B. Blood draw orders:

1. BUN, creatinine, HCO₃, Na, K, Cl, and glucose 8 a.m. and 6 p.m. each day during dialysis

C. Notify physician immediately for:

1. Poor dialysate flow
2. Severe abdominal pain or distention
3. Bright red blood or cloudy dialysate drain
4. Dialysate leak or purulent drainage around catheter exit site
5. Blood pressure of < _____ mm Hg systolic
6. Respiration rate of > _____/minute, or severe shortness of breath
7. Temperature of > _____ °C
8. Two consecutive positive exchanges
9. Single positive exchange balance (dialysate-IN – dialysate-OUT) of ≥1,000 mL
10. If negative balance exceeds _____ L over _____ hours

BUN, blood urea nitrogen.

2. **Exchange time.** This is the combined time required for inflow, dwell, and drain. If the aim is to maximize small-solute clearance, the exchange time should be relatively short at about 1–2 hours, but in CEPD, longer times are routine.
 - a. **Inflow time.** Inflow is by gravity or hydraulically pumped with a cycler and usually requires about 5–10 minutes (200–300 mL/min). Inflow time is dictated by the volume to be infused and, with manual systems, the height of the dialysis solution above the patient's abdomen. It may be prolonged due to kinking of the tubing or increased inflow resistance by intra-abdominal tissues in close proximity to the catheter tip. On initiation of acute PD, some patients may experience pain or cramping with inflow of PD solution. This may result from the hypertonic and acidic nature of the PD fluid and often improve with time but, when severe, may be relieved by slowing the dialysate inflow rate for several exchanges. Otherwise, inflow time should be kept to a minimum to maximize dialysis efficiency. Cold PD solution can result in discomfort and hypothermia, and so the solution should be warmed to 37°C before infusion.
 - b. **Dwell time.** The dwell period is the time during which the total exchange volume is present in the peritoneal cavity (i.e., the time from the end of inflow to the beginning of outflow). When initiating PD in acutely ill and catabolic patients, the

usual dwell time is 30 minutes to achieve an exchange time of 60 minutes. With a 2-L exchange volume, as much as 48 L of fluid can be exchanged daily. Given a peritoneal membrane with average transport characteristics, the urea concentration in the drained dialysate will be approximately 50%–60% of that in the plasma (D/P ratio of 0.5–0.6 at 1 hour). Thus, with an aggressive dialysis exchange rate of 2 L/hr, the plasma urea clearance could approximate 24–29 L per day ($0.5\text{--}0.6 \times 48$ L per day) or 168–202 L per week. If the patient is not very catabolic, a longer dwell time (e.g., 1.5–6 hours) can often be used. With a 4-hour exchange time (dwell time 3.5 hours), the dialysate urea concentration is, on average, 90% of that in the plasma (D/P ratio of 0.9 at 4 hours). This leads to a plasma urea clearance of at least 11 L per day (0.9×12 L per day), or 77 L per week. Assuming an ultrafiltration rate of 1 L per day, this would add 6.3 L of clearance per week, making a total clearance of 83 L per week. In terms of weekly Kt/V urea (see what follows), the weekly clearance of 83 L is the $(K \times t)$ term. For a 70-kg male patient with a V of 42 L, weekly $(K \times t)/V$ would be 83/42 or about 2.0.

- c. **Outflow time.** Outflow of spent dialysate is by gravity and usually requires 20–30 minutes. Outflow time depends on the total volume to be drained, the resistance to outflow, and, with manual methods, the difference in height between the patient's abdomen and the drainage bag. In many patients, particularly those with large abdomens, the first exchange may not drain completely (often only 1–1.5 L is retrieved) due to initial filling of poorly draining areas of the abdomen. As long as marked abdominal distension is not present, a second exchange of 2 L can be cautiously instilled. Subsequent drainage usually proceeds normally.

3. **Choosing the dialysis solution dextrose concentration**

- a. **Standard 1.5% dextrose (glucose monohydrate).** This concentration of dextrose (approximately 1,360 mg glucose/dL [75 mmol/L]) will, in general, exert an osmotic force sufficient to remove 50–150 mL fluid/hr (although this may vary from patient to patient) when using a 2-L exchange volume and a 60-minute exchange time. This ultrafiltration rate could translate into fluid removal of 1.2–3.6 L per day.
- b. **Higher concentrations of dextrose.** Greater fluid removal can be achieved with higher dextrose concentrations. A 4.25% dextrose solution can result in an ultrafiltration rate of 300–400 mL/hr. Acutely, this degree of fluid removal can be required for the treatment of congestive heart failure or marked volume overload. However, continued use of the 4.25% solution could theoretically result in the removal of 7.2–9.6 L per day and cause marked hypernatremia. In practice, this degree of fluid removal is rarely required. Available dextrose solutions (i.e., 1.5%, 2.5%, or 4.25% exchanges) can be adjusted to provide the level of ultrafiltration desired. Once the patient is euvolemic, one can resume using 1.5% solution for all exchanges.

4. **Dialysis solution additives.** When injecting any additive into PD solution bags, sterile technique must be followed in order to prevent bacterial contamination of the dialysis solution and peritonitis.

- a. **Potassium.** Standard PD solutions contain no potassium (K). In general, after the initial exchanges, serum K concentrations are within the normal range, unless the patient is very catabolic. In fact, losses of K can be high in acute PD. Such removal may cause serious K depletion and cardiovascular instability. This can be prevented or corrected by adding K to the dialysis solution. When serum K is lower than 4 mM, K 4.0–5 mM can be added to the PD solutions to minimize the risk of hypokalemia.
 - b. **Heparin.** Sluggish dialysate flow from catheter obstruction by fibrin or blood clots may occur in acute PD, often as a result of the slight bleeding that may accompany catheter insertion or irritation of the peritoneum by the catheter. Heparin (500–1,000 units/L) added to the dialysis solution can be helpful in preventing or treating this problem. Because heparin is absorbed minimally through the peritoneum, there is no increased risk of bleeding.
 - c. **Insulin.** Because glucose is absorbed from the dialysis solution, supplemental insulin administration may be required for the diabetic patient undergoing acute PD. Insulin can be given subcutaneously or intravenously, or regular insulin may be added to the PD solution before infusion. The blood glucose level must be monitored closely, and the dose of insulin tailored to the needs of the patient.
 - d. **Antibiotics.** Intraperitoneal administration of antibiotics is an efficient route for treating peritonitis. In general, antibiotics should not be given intraperitoneally to treat systemic infections.
- B. How to measure dose in acute PD.** It is important to ensure that acute PD is delivering an adequate amount of dialysis for the AKI patient. Adequacy is generally assessed by measuring the Kt/V urea nitrogen delivered by the PD. This is done by measuring the urea concentration in representative samples of dialysate and plasma in order to calculate a D/P ratio for urea. This is multiplied by the total daily dialysate drain volume and divided by the estimated volume of distribution of urea using anthropometric equations for total body water such as the Watson equation (see Chapter 25). However, patients with AKI often are fluid loaded, and urea distribution volume often will be considerably higher than predicted by such equations.

MEASUREMENT OF DELIVERED Kt/V

$$\begin{aligned}
 Kt/V &= \text{clearance of urea} \times \frac{\text{time}}{\text{volume of distribution of urea}} \\
 &= \frac{\text{mean dialysate urea nitrogen (mg/dL)}}{\text{mean serum urea nitrogen (mg/dL)}} \\
 &\quad \times \frac{\text{drained 24 hr volume in mL}}{\text{estimated volume of distribution of urea (mL)}}
 \end{aligned}$$

This is multiplied by 7 to yield the weekly Kt/V urea

IV. **COMPLICATIONS.** A number of problems may arise during the course of acute PD. These include mechanical, infectious, technical, and metabolic problems.

- A. **Mechanical complications.** Incomplete drainage may lead to “overflow,” which is progressive intraperitoneal accumulation of dialysate, with attendant discomfort, distention, and even respiratory compromise. Catheter-related problems resulting in poor drainage are the main cause of this, although intra-abdominal adhesions or bowel distention can contribute. One should observe the drainage cycle and make sure that the patient is emptying completely during the allowed drainage period. Mechanical problems occur in up to 10% of patients undergoing acute PD.
- B. **Peritonitis.** Peritonitis rates have ranged from 4% to 41% during acute PD treatment in different studies. This occurs most often after 48 hours and is more common with open than with closed-drainage systems. Although infections from gram-positive organisms dominate, there is a high incidence of gram-negative or fungal-related peritonitis in acute PD. This may be a reflection of the severity of illness in patients requiring acute PD as well as predisposing factors, such as the prolonged use of multiple antibiotics.
- C. **Hyperglycemia.** The amount of glucose absorbed during PD varies significantly between patients due to differences in peritoneal membrane permeability and the concentrations of dextrose used. Fast transporters absorb glucose more quickly. Among patients undergoing CAPD with four exchanges per day, 60%–80% of the glucose instilled is absorbed. With more rapid exchanges, such as are used with automated PD, glucose absorption is reduced as the number of cycles is higher and dwell times are shorter. In a study of 31 AKI patients treated with HVPD, absorption of glucose was about 35% of that instilled during treatment (Goes, 2013). In order to avoid or reduce hyperglycemia in patients treated with PD, glucose absorption from dialysate should be taken into consideration when calculating total energy intake for PD patients. Additionally, when hyperglycemia is detected, frequent blood glucose monitoring (approximately every 6 hours) should be performed, and the intravenous (IV), subcutaneous, and/or intraperitoneal (IP) administration of insulin should be considered. In studies of patients undergoing HVPD, glucose levels were well maintained (between 130 and 170 mg/dL; 7.2 and 9.4 mmol/L) using both IV and IP insulin.
- D. **Hypernatremia.** Due to the low sieving coefficient for sodium, which is related to water passage via aquaporin channels, the ultrafiltrate generated in PD has a sodium concentration of approximately 70 mmol/L. Increased losses of water associated with frequent hypertonic exchanges can therefore lead to hypernatremia. Intravenous replacement of losses with hypotonic fluids or replacing half of the losses with 5% dextrose water prevents the development of hypernatremia.
- E. **Hypoalbuminemia.** With the frequent exchanges utilized in acute PD, protein loss via the dialysate can be as high as 10–20 g per day and up to twice this amount if peritonitis develops. Oral or parenteral hyperalimentation should be considered in patients for whom malnutrition is deemed a problem. In general, protein losses through dialysis should not limit the use of PD in AKI patients.

V. **INFRASTRUCTURE REQUIRED FOR “URGENT START” PD.** A successful urgent start PD program requires a number of components (Ghaffari, 2013a). First, there needs to be prompt access to

Tenckhoff catheter placement by a surgeon or nephrologist or radiologist. Second, there needs to be a willingness of nephrologists in the center to alter their previous practice and consider the urgent start PD option in CKD patients who present acutely with uremia or fluid overload. Third, there needs to be an ability to carry out some form of low-volume acute PD, typically delivered by aycler with the patient in the supine position, in a ward setting for at least a few days to control acute uremia and fluid overload. Fourth, there needs to be a willingness and ability to train the patient in the PD unit on short notice once the initial clinical stabilization on PD has occurred. Otherwise, an unacceptably long inpatient admission waiting for a training spot would result. These requirements mean that an urgent PD program will only work with flexibility and cooperation between hospital ward and PD unit staff and physicians, with overall leadership from an enthusiastic nephrologist.

References and Suggested Readings

- Arramreddy R, et al. Urgent start peritoneal dialysis: a chance for a new beginning. *Am J Kidney Dis*. 2014;63:390–395.
- Asif A. Peritoneal dialysis access: related procedures by nephrologists. *Semin Dial*. 2004;17:398–406.
- Bai ZG, et al. Bicarbonate versus lactate solutions for acute peritoneal dialysis. *Cochrane Database Syst Rev*. 2010;8:CD007034.
- Burdmann EA, Chakravarthi R. Peritoneal dialysis in acute kidney injury: lessons learned and applied. *Semin Dial*. 2011;24:149–156.
- Chionh CY, et al. Acute peritoneal dialysis: what is the ‘adequate’ dose for acute kidney injury? *Nephrol Dial Transplant*. 2010;25:3155–3160.
- Chionh CY, et al. Use of peritoneal dialysis in AKI: a systematic review. *Clin J Am Soc Nephrol*. 2013;8:1649–1660.
- Chitalia VC, et al. Is peritoneal dialysis adequate for hypercatabolic acute renal failure in developing countries? *Kidney Int*. 2002;61:747–757.
- Gabriel DP, et al. High volume peritoneal dialysis for acute renal failure. *Perit Dial Int*. 2007;27:277–282.
- Gabriel DP, et al. High volume peritoneal dialysis vs daily hemodialysis: a randomized, controlled trial in patients with acute kidney injury. *Kidney Int*. 2008;73:87–93.
- George J, et al. Comparing continuous venovenous hemodiafiltration and peritoneal dialysis in critically ill patients with acute kidney injury: a pilot study. *Perit Dial Int*. 2012;31:422–429.
- Ghaffari A, Kumar V, Guest S. Infrastructure requirements for an urgent-start peritoneal dialysis program. *Perit Dial Int*. 2013a;33:611–617.
- Ghaffari A, et al. PD first: peritoneal dialysis as the default transition to dialysis therapy. *Semin Dial*. 2013b;26:706–713.
- Goes CR, et al. Metabolic implications of peritoneal dialysis in patients with acute kidney injury. *Perit Dial Int*. 2013;33:635–645.
- Guest S, et al. Intermittent peritoneal dialysis: urea kinetic modeling and implications of residual kidney function. *Perit Dial Int*. 2012;32:142–148.
- ISPD Guidelines: peritoneal dialysis for acute kidney injury. *Perit Dial Int*. 2014;34: 494-517.
- Ivarsen P, Povlsen JV. Can peritoneal dialysis be applied for unplanned initiation of chronic

dialysis? *Nephrol Dial Transplant*. 2014, in press.

Phu NH, et al. Hemofiltration and peritoneal dialysis in infection-associated acute renal failure in Vietnam. *N Engl J Med*. 2002;347:895–902.

Ponce D, Balbi AL. Peritoneal dialysis for acute kidney injury: a viable alternative. *Perit Dial Int*. 2011a;31:387–389.

Ponce D, et al. Different prescribed doses of high-volume peritoneal dialysis and outcome of patients with acute kidney injury. *Adv Perit Dial*. 2011b;27:118–124.

Ponce D, Balbi AL, Amerling R. Advances in peritoneal dialysis in acute kidney injury. *Blood Purif*. 2012a;34:107–116.

Ponce D, et al. High volume peritoneal dialysis in acute kidney injury: indications and limitations. *Clin J Am Soc Nephrol*. 2012b;7:887–894.

Ponce D, et al. A randomized clinical trial of high volume peritoneal dialysis versus extended daily hemodialysis for acute kidney injury patients. *Int Urol Nephrol*. 2013;45:869–879.

Thongboonkerd V, Lumlertgul D, Supajatura V. Better correction of metabolic acidosis, blood pressure control, and phagocytosis with bicarbonate compared to lactate solution in acute peritoneal dialysis. *Artif Organs*. 2001;25:99–108.

The prescription of chronic peritoneal dialysis involves a number of elements. Initially, there is the choice of peritoneal dialysis modality between continuous ambulatory peritoneal dialysis (CAPD) and cycler or automated peritoneal dialysis (APD) and their variants. Then there is the selection of a specific prescription based on clearance, ultrafiltration, and nutritional/metabolic requirements. The term “adequacy” is often used in this context and usually refers specifically to the quantity of clearance delivered but can also be used in a broader sense to reflect the quality of the dialysis prescription as a whole. Please review Chapter 21 (Physiology) and 22 (Equipment) at this time, as many concepts discussed in those chapters will not be repeated here.

I. CHOICE OF A PERITONEAL DIALYSIS (PD) TREATMENT MODALITY (Table 25.1, Fig. 25.1)

A. Modalities of peritoneal dialysis therapy

1. **CAPD.** The simplicity of CAPD, the ease of doing it at home, its relatively low cost, and the associated freedom from dialysis machinery have combined to make it historically the most popular chronic peritoneal dialysis modality. It provides continuous therapy and a steady physiologic state. Control of body fluid volume can usually be achieved, and normalization of blood pressure is possible in most patients.

The principal disadvantage of CAPD for many patients is the requirement for multiple procedural sessions (usually four per day), each taking up 30–40 minutes of patient time. While these can be done away from home, the requirement for sterility and access to supplies usually means that the patient returns home, and so this may constrain daily activities somewhat. Frequency of procedures may also be an issue where relatives or other caregivers are carrying out the exchanges for the patient. Other factors are limitations on dwell volumes due to increased intraperitoneal pressure and a limited range of solute clearance. Episodes of peritonitis occurring as often as once every 12 months were a significant disadvantage in the past; however, with improved transfer sets and connecting devices, such occurrences have been markedly reduced and successful programs report rates of one peritonitis episode every 3 years or fewer.

	CAPD	APD with Day Dwell	APD without Day Dwell
PD solution used (L/wk)	56–72	70–120	84–120
Dialysis time (hr/wk)	168	168	70
Time on machine (hr/wk)	0	63–70	63–70
Number of procedures/wk	28	14	14
<i>Kt/V</i> urea/wk	1.5–2.4	1.5–2.6	1.2–2.0
CrCl (L/wk)	40–70	40–70	25–50

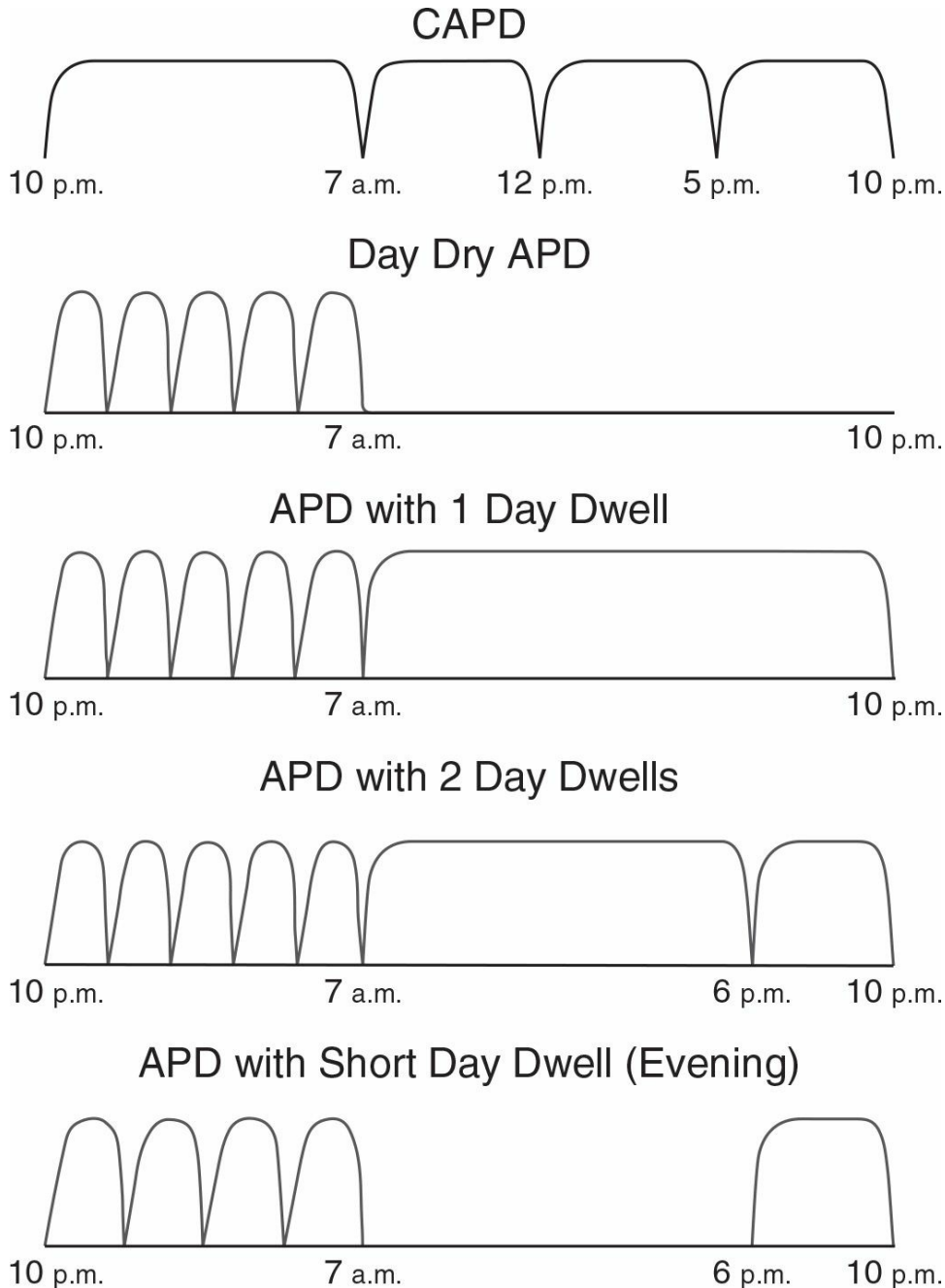

FIGURE 25.1 Diagrammatic representation of various CAPD and APD prescriptions.

2. **APD.** This has become very popular over the past 10–15 years and, in many wealthier countries, is being used in the majority of peritoneal dialysis patients. The main advantage of APD, compared with CAPD, is the lesser number of on–off procedures required each day—typically two versus four for CAPD—and none during the daytime. All connections and preparation of equipment usually take place in the privacy of the

home so that psychological adjustment is facilitated and patient fatigue and “burnout” may be reduced. APD is an attractive treatment option for active individuals who would be inconvenienced by the interruptions in daily routine that are required with CAPD. APD is also the therapy of choice for most patients who require assistance in carrying out their dialysis (e.g., children, the dependent elderly, and nursing home residents).

The main disadvantages of APD relative to CAPD are the need for a cycler, the greater cost, and the slightly greater complexity.

APD has classically been divided into APD with a day dwell, often called continuous cycling peritoneal dialysis (CCPD), and day dry APD (Fig. 25.1), often called nocturnal intermittent peritoneal dialysis (NIPD). These modalities have already been described in Chapters 21 and 22.

An alternative form of APD is tidal peritoneal dialysis (TPD). This modality uses an initial fill volume followed by partial drainage at periodic intervals (Fernando, 2006). The principal purpose of TPD was to enhance clearance of small solutes by avoiding the normal loss of dialysis time associated with inflow and drainage. In terms of clearance, the advantage of TPD over standard APD is not seen unless very large quantities of dialysis solution are used. The main use of TPD nowadays is to minimize drain pain during nighttime cycling. The main disadvantage of high-volume TPD is increased cost and complexity, and it is not widely used.

- B. CAPD or APD: Which modality to choose?** This decision should take into consideration both patient preferences and the need to provide a medically optimal peritoneal dialysis prescription. Patient preferences may be based on lifestyle, employment, place of residence, ability to perform the various modalities of PD, comfort with cycler technology, and the degree of family and social support. In the past, peritoneal transport status and its influence on clearance and fluid removal were thought to be critical in choosing between CAPD and the different types of APD, but there is now an increasing sense that these aspects were overstated and that lifestyle factors should be given more emphasis.

APD was previously thought to be better than CAPD for managing volume status. However, the phenomenon of sodium sieving (see Chapter 26) is more apparent with the short-cycled dwell times of APD, and this, along with the risk of net fluid resorption with long day dwells, has led to concerns about adequacy of sodium removal with APD. One recent study suggests less salt removal and a higher prevalence of systolic hypertension with APD than with CAPD, but this was not a randomized trial, and there is no consensus that these findings are generalizable (Rodriguez-Carmona, 2004). Salt and water removal require close attention on both CAPD and APD, but there is insufficient evidence to justify it being a factor in initial modality selection.

Risk of peritonitis is another medical factor that may arise when deciding between CAPD and the variants of APD. One randomized trial done over two decades ago showed less peritonitis on APD, but both modalities have changed since then, and there is now no consensus that one or the other is more likely to predispose to peritonitis.

A third consideration is cost. CAPD generally is cheaper than APD. Dialysis programs have to deal with financial constraints, and in some settings, patients may have to

bear some or all of the costs.

II. CHOICE OF A PRESCRIPTION

A. Clearance targets

1. **Weekly Kt/V urea.** Clearance targets in PD are set in terms of weekly urea clearance (Kt) normalized to the patient's estimated urea distribution volume (V). Current guidelines aim for a Kt/V urea target of at least 1.7. Previously, this target had been set higher, at 2.0 or even greater for noncontinuous forms of PD, but the guidelines were lowered based on further trial evidence, and in particular, the randomized ADEMEX study (Paniagua, 2002), which found no difference in outcomes between patients assigned to receive a higher versus a lower dose of PD. In the ADEMEX trial, the average weekly Kt/V was 2.1 in the patients assigned to more dialysis, compared to 1.6 in the lower-dose group. Current guidelines do not set different targets for continuous and noncontinuous forms of PD (e.g., day dry APD), nor do they set different targets based on peritoneal transport status. A similar trial from Hong Kong (Lo, 2003) also failed to find a benefit of higher doses of PD.
2. **Weekly creatinine clearance (CrCl) per 1.73 m².** Previous guidelines also set a weekly CrCl target in addition to the Kt/V urea target. The creatinine target was normalized to 1.73 m² body surface area and was in the range of 60/1.73 m² L per week. The idea of setting a separate creatinine target was to model a uremic toxin that had slightly higher molecular weight than urea (113 vs. 60 Da) and that was not so rapidly removed by diffusion. Most current guidelines no longer recommend a minimum level of weekly CrCl as such targets have not been shown to be of any additional value over Kt/V targets. However, they do reflect clearance of slightly larger molecules than urea, and so European, but not US, guidelines suggest an additional CrCl target of 45/1.73 m² L per week (Dombros, 2005).
3. **Should residual kidney function be counted in the adequacy target?** Greater residual renal clearance has repeatedly been shown to be associated with superior patient survival; in fact, it has been difficult to show a similar survival effect for peritoneal clearance, at least within the range of prescriptions in typical clinical use (Churchill, 1995). Some have suggested that the weekly Kt/V urea target of 1.7 should be met by peritoneal clearance alone and that residual renal clearance should be treated as a precious bonus. KDOQI, Canadian, and European guidelines, however, all recommend that peritoneal and renal Kt/V can be added to achieve the target.
4. **Same Kt/V target for CAPD and APD.** The previous idea that target clearances for APD should be higher than those for CAPD because APD is somewhat more intermittent is now thought to be unjustified and to introduce unnecessary complexity.

- B. **Measurement of clearance** (Table 25.2). Clearance in peritoneal dialysis can be measured in terms of Kt/V urea and additionally as CrCl/1.73 m². Both clearances comprise a peritoneal and a residual kidney component. Residual kidney function lasts longer in PD than in hemodialysis and accounts for a greater proportion of total clearance.

***Kt/V*:**

Kt = Total ***Kt*** = peritoneal ***Kt*** + renal ***Kt***

Peritoneal ***Kt*** = 24-hr dialysate urea nitrogen content/serum urea nitrogen

Renal ***Kt*** = 24-hr urine urea nitrogen content/serum urea nitrogen

***V* (by Watson formula):**

$V = 2.447 - 0.09516 A + 0.1704 H + 0.3362 W$ (in males)

$V = -2.097 + 0.1069 H + 0.2466 W$ (in females)

where A = age (y); H = height (cm), and W = weight (kg)^a

CrCl:

CrCl = total **CrCl** corrected for 1.73 m² BSA

Total **CrCl** = peritoneal **CrCl** + renal **CrCl**

Peritoneal **CrCl** = 24-hr dialysate creatinine content/serum creatinine

Renal **CrCl**^b = 0.5 (24-hr urine creatinine content/serum creatinine + 24-hr urine urea nitrogen content/serum urea nitrogen)

BSA (DuBois formula):

$BSA (m^2) = 0.007184 \times W^{0.425} \times H^{0.725}$

where BSA = body surface area (m²), W = weight (kg)^a and H = height (cm)

^aAnthropometric (median standard or ideal body weight as per Appendix B) instead of actual body weight may be used for calculation of *V* or BSA.

^bFor PD adequacy purposes, renal “CrCl” is the average of the urinary creatinine and urea creatinine clearances.

1. **Measurement of weekly *Kt/V* urea.** Peritoneal *Kt/V* is calculated by performance of a 24-hour collection of dialysate effluent and measurement of its urea content. This is then divided by the average plasma urea level for the same 24-hour period to give a clearance term, *Kt* (Table 25.3). The timing of the plasma urea sample is not critical in CAPD because it is relatively constant at all times. In APD, blood urea is not quite so constant throughout the day; ideally, therefore, it is best to take a measurement in the middle of the noncycling daytime period, which is typically between 1:00 p.m. and 5:00 p.m. and is thought to represent approximately the average blood urea levels for the day.

Residual renal *Kt* urea is calculated in the same way using a 24-hour collection of urine. The two (peritoneal and renal) *Kt* terms are then combined to give total *Kt* per day, and this value is normalized to *V*, which represents total body water. It is recommended that *V* be estimated using one of the standard formulas for total body water, such as those of Watson or of Hume–Weyers. These are based on patient age, sex, height, and weight (Table 25.2). This then gives a daily value for *Kt/V* urea, which then needs to be multiplied by 7 to give a weekly value. In the calculation of *V*, normalization of *Kt* to the patient’s ideal or standard *V* (calculated using the ideal or

standard body weight as described in Appendix B) rather than actual V (calculated from actual body weight) is recommended. This makes it easier to achieve targets in obese patients and is appropriate, in that most do not believe that clearance requirements should rise in proportion to body fat. Conversely, wasted malnourished patients will require more dialysis to achieve targets if clearance is corrected to their standard or ideal body weight. These weights are calculated from anthropometric values, as described in Appendix B, and then the standard or ideal body weight value should be used in the Watson equation to calculate the value for an adjusted V .

TABLE

25.3

Examples of Clearance Calculations in CAPD and APD

1. A 50-year-old man weighing 66 kg has no residual renal function. He is on CAPD with four 2.5-L exchanges daily, and his net UF is 1.5 L. His V by the Watson formula is 36 L, and his BSA by the DuBois formula is 1.66 m². Serum urea nitrogen is 70 mg/dL (25 mmol/L), and serum creatinine is 10 mg/dL (884 μmol/L). The urea nitrogen and creatinine (after correction for glucose) levels in the 24-hr dialysate collection are 63 mg/dL (22.5 mmol/L) and 6.5 mg/dL (575 μmol/L), respectively. Calculate his Kt/V and CrCl.

$$Kt \text{ urea/d} = 24\text{-hr drain volume} \times D/P \text{ urea} = 11.5 \text{ L} \times 63/70 = 10.35 \text{ L/d. Daily } Kt/V = 10.35 \text{ L}/36 \text{ L} = 0.288$$

$$\text{Weekly } Kt/V = 0.288 \times 7 = 2.02$$

$$\text{Creatinine clearance per day} = 24\text{-hr drain volume} \times D/P \text{ creatinine} = 11.5 \text{ L} \times 6.5/10 = 7.48 \text{ L/d. Corrected for } 1.73 \text{ m}^2 \text{ BSA} = 7.48 \times 1.73/1.66 = 7.80 \text{ L/d. Weekly CrCl}/1.73 \text{ m}^2 = 7.8 \times 7 = 55 \text{ L/wk.}$$

2. A 48-year-old woman on APD weighs 63 kg and does five 2.4-L cycles nightly plus a 6-hr 2-L day dwell. Her V by Watson is 32 L, and her BSA by DuBois is 1.60 m². Her 24-hr dialysate drain volume is 15 L, indicating 1 L net UF. Her pooled dialysate collection has a urea nitrogen level of 48 mg/dL (17.1 mmol/L) and a creatinine level (after correction for glucose) of 4.5 mg/dL (398 μmol/L). Her mid-afternoon serum urea nitrogen is 65 mg/dL (23.2 mmol/L), and serum creatinine is 9 mg/dL (796 μmol/L). Her urinary urea and creatinine clearance are 2 and 4 mL/min, respectively.

Calculate her total weekly Kt/V and creatinine clearance.

$$\text{Peritoneal } Kt = \text{daily drain volume} \times D/P \text{ urea} = 15 \text{ L} \times 48/65 = 11.1 \text{ L. Peritoneal } Kt/V = 11.1 \text{ L}/32 \text{ L} = 0.35/\text{d} = 2.45/\text{wk.}$$

$$\text{Renal urea clearance} = \text{renal } Kt \text{ urea} = 2 \text{ mL/min} = 20 \text{ L/wk. Renal } Kt/V = 20/32 = 0.63/\text{wk.}$$

$$\text{Total } Kt/V = \text{peritoneal plus renal } Kt/V = 2.45 + 0.63 = 3.08/\text{wk}$$

$$\text{Peritoneal creatinine clearance} = \text{daily drain volume} \times D/P \text{ creatinine} = 15 \text{ L} \times 4.5/9 = 7.5 \text{ L.}$$

$$\text{Corrected for } 1.73 \text{ m}^2 \text{ BSA} = 7.5 \times 1.73/1.60 = 8.1 \text{ L/d} = 57 \text{ L/wk.}$$

$$\text{Renal creatinine clearance (for this purpose)} = \text{mean of renal urea and renal creatinine clearance} =$$

mean of 2 and 4 mL/min = 3 mL/min = 30 L/wk. Corrected for 1.73 m² BSA = $30 \times 1.73/1.60 = 32.4$ L/wk.

Total creatinine clearance/1.73 m² = 57 + 32.4 = 89.4 L/wk.

D/P, dialysate/plasma; UF, ultrafiltration.

2. **Measurement of weekly CrCl/1.73 m².** The measurement of CrCl is similar to that of Kt/V (Tables 25.2 and 25.3). Again, the peritoneal component is calculated by measuring the creatinine content of a 24-hour collection of dialysate effluent, and this is then divided by the serum creatinine. The way that renal CrCl is added to the peritoneal component differs from the procedure for Kt/V urea. Residual renal CrCl is known to markedly overestimate true glomerular filtration rate in most patients; therefore, it is conventional to add the average of the urinary urea and creatinine clearances to the peritoneal clearance to give the total CrCl. The total daily “creatinine clearance” is then normalized to 1.73 m² body surface area (BSA), with BSA estimated using the formula of DuBois or Gehan and George (see Appendix B). This daily clearance value is then multiplied by 7 to give a weekly CrCl/1.73 m². Normalization to standard or ideal body weight can be done in the same way as for Kt/V urea, where the weight from Appendix B is used to calculate an adjusted BSA value.
 - a. **Analytical problem in measuring creatinine in glucose-containing dialysate.** The high glucose levels found in dialysate artifactually elevate the measurement of creatinine in some biochemical assays, and each laboratory should make a correction for this based on its own experience. This may be done by spiking unused bags of dialysis solution containing various dextrose concentrations with a known amount of creatinine and then performing the assay, enabling derivation of the appropriate correction factor.
 3. **Frequency of measurements.** It is recommended by KDOQI that in peritoneal dialysis patients Kt/V urea should be measured within 1 month of initiating peritoneal dialysis and every 4 months subsequently, as well as after every significant change in the peritoneal dialysis prescription or in the patient’s clinical status. Urinary clearance should be measured every 2 months if an incremental approach to peritoneal dialysis is being used. Some will find these requirements unduly onerous, and a compromise in more stable patients who have been achieving their targets would be to measure clearances every 6 months.
- C. **Determinants of clearance** (Table 25.4). The total weekly Kt/V urea achieved on standard peritoneal dialysis prescriptions typically ranges from as little as 1.2 to as much as 3.0 a week. Similarly, CrCl/1.73 m² can range from as little as 30 L per week to as much as 150 L per week. The major source of this variation is residual kidney function.- 1. **Residual kidney function.** This can easily account for as much as 50% of total clearance at the initiation of peritoneal dialysis. There is some evidence from randomized controlled trials that residual renal function can be preserved in patients on CAPD by treatment with angiotensin-converting enzyme inhibitors or angiotensin receptor

blockers (Li, 2003b). It is always wise to minimize exposure to potentially nephrotoxic agents, including aminoglycosides, radiocontrast dyes, and nonsteroidal anti-inflammatory drugs. Episodes of volume depletion should be avoided. It has been suggested that preservation of residual function is better on CAPD than on APD, but this is not a consistent finding.

1. Nonprescription factors:

Residual renal function

Body size

Peritoneal transport characteristics

2. Prescription factors:**a. CAPD:**

Dwell volume

Frequency of exchanges

Tonicity of dialysis solution

b. APD:

Number of day dwells

Volume of day dwells

Tonicity of day dwells

Time on cycler

Cycle frequency

Cycler dwell volumes

Tonicity of cycler solution

-
- 2. Peritoneal transport status.** This is an important determinant of clearances, especially in APD, where the short-duration cycles limit solute equilibration between plasma and dialysate to a greater degree than is the case for the longer-duration dwells in CAPD (Blake, 1996). Peritoneal transport is measured by the peritoneal equilibration test (PET), as discussed in Chapter 21. In general, low transporters achieve greater clearances with high-volume, long-duration dwells, whereas high transporters do well with short-duration dwells. However, these differences are less pronounced for urea as compared to creatinine because the lower molecular weight of urea leads to relatively rapid diffusion, even in low transporters. Transport status is now recognized as a determinant of patient and technique survival on CAPD, with low transporters doing best despite clearances that tend to be lower than those that their high-transport counterparts achieve. It is likely that this is partly due to the importance of ultrafiltration and its interaction with cardiovascular morbidity.
 - 3. Body size.** Given that clearance indices are normalized to BSA or total body water, this

is an important determinant. When standard or ideal body weight, rather than actual body weight, is used to calculate an adjusted V and an adjusted BSA, the impact of current weight will be lessened. While large body size makes it harder to achieve higher clearance targets, there is controversy about whether larger patients have worse outcomes.

D. Prescription strategies to achieve clearance targets in chronic peritoneal dialysis

1. **CAPD.** The typical initial CAPD prescription continues to be 4×2 L daily. Some centers will start with 4×2.5 L in larger patients, especially if residual renal function is low. Some use 3×2 L if patients are small or residual renal function is substantial. In Hong Kong, where mean body weight is less than in Western countries, good results have been reported using 3×2 L initially in almost all patients. When icodextrin is available, some centers use it routinely for the nocturnal dwell, but it is more expensive, and others use it only in high transporters or in patients in whom fluid resorption at night becomes a clinical problem.

If a clearance measurement is unexpectedly low, it should be repeated as there is significant variation and potential for error. If clearance targets are not being achieved, a prescription change needs to be considered. The choice of strategy should take into account the increment in clearance required, the patient's transport status, volume and nutritional/metabolic considerations, and, perhaps most importantly, the likely effect on lifestyle for the patient and his or her caregivers, as a disruptive prescription may lead to noncompliance or burnout and consequent technique failure. To increase peritoneal Kt/V in CAPD patients, there are three options (Table 25.4): increase the dwell volumes, increase the frequency of daily exchanges, and/or increase dialysis solution tonicity, thereby augmenting ultrafiltration.

- a. **Increasing the dwell volumes.** This increases clearance because the total volume of solution delivered daily rises and the larger dwell volume leads to only a small decrease in urea and creatinine equilibration. In larger patients, for example, a switch from 4×2 L to 4×2.5 L CAPD involves a 25% increase in instilled volume and will typically raise peritoneal Kt/V by 18% to 20%. However, in smaller patients, and especially when 3-L dwell volumes are used, there may be greater falloff in equilibration and the percentage of increase in clearance is reduced. To achieve clearance targets in larger (>75 kg) anuric patients, typically at least 2.5-L dwell volumes are required (Virga, 2014). Some programs prefer to initiate such patients on larger dwell volumes to begin with, whereas others use 2-L volumes until residual renal function fades and then make the switch. The main disadvantage of increasing dwell volumes is that some patients may complain of back pain, abdominal distention, and even shortness of breath. This can be minimized if the increased volumes are introduced at the time of initiation of peritoneal dialysis, before the patient becomes accustomed to smaller volumes. Studies show only a small increase in the risk of hernias and leaks with the associated rise in intraperitoneal pressure. This rise in pressure may also impair ultrafiltration somewhat, but this effect is partly offset by the longer persistence of the glucose osmotic gradient when higher volumes are used.

- b. **Increasing the frequency of daily exchanges.** Most CAPD patients do four exchanges daily. Increasing the number of exchanges from four to five per day generally does not have a major effect on urea equilibration, which remains at approximately 85% to 90% in patients with average transport characteristics. This will not be the case if patients do not ensure that the five daily exchanges are well spaced, with at least a 4-hour dwell time for each. There will be a noticeable drop in creatinine concentration in the drained effluent because the equilibration curve for creatinine is typically still rising 4 hours after the dwell commences. Thus, increasing the frequency of exchanges is less effective than increasing dwell volumes, especially where CrCl is concerned.

An additional disadvantage of increasing the frequency of exchanges to five daily is that it may interfere with a patient's lifestyle and lead to noncompliance or burnout. Also, use of five exchanges per day is 25% more costly than four per day, whereas 2.5-L bags of dialysis solution are not usually much more expensive than the 2.0-L size.

- c. **Increasing the tonicity of the dialysis solutions.** This strategy increases both ultrafiltration and clearance. It is used in some centers, but there are increasing concerns that it may lead to a higher incidence of hyperglycemia, hyperlipidemia, obesity, and long-term peritoneal membrane damage.
2. **APD.** The initial APD prescription is quite variable across centers. A typical starting volume is 10 or 12 L daily but some use 15 L, especially in larger patients. Typical cycler time is 8–10 hours, and dwell volumes on the cycler in the daytime are usually 2 L or, in larger patients, 2.5 L.

Some start with a day dry prescription if the patient has good residual renal function and/or is small. Others use a day dwell from the start but may shorten the duration of the dwell to avoid fluid resorption, especially in higher transporters, and then either leave the patient “dry” for part of the day or add a second dwell. If icodextrin is available, some centers will use it routinely for the day dwell while others will prescribe it only in high transporters or in patients who have fluid resorption problems and/or in those in whom there are metabolic concerns about excess glucose absorption, for example, diabetic or obese patients.

Peritoneal clearance in APD can be increased using a number of different strategies (Table 25.4) (Durand, 2003). In order of usefulness, these are as follows:

- a. **Introduction of a day dwell.** In day dry patients, the best way to increase clearance is to add a day dwell. This raises both Kt/V and CrCl, but the effect on CrCl is greater because creatinine equilibration is more dependent on longer dwell times. Typically, adding a day dwell to a day dry APD patient will increase daily peritoneal Kt/V and CrCl by 25% to 50%, and so this is very cost-effective (Blake, 1996). Further increases in clearance can be achieved by adding a second or even a third day dwell, although this is less likely to be required with present more modest Kt/V urea clearance targets. These added exchanges can be done using the docking-station approach or, if it suits the patient better, using manual CAPD tubing in the conventional way. Day dwell volumes can be titrated to

maximize clearance while minimizing mechanical symptoms. This strategy does have the disadvantages of requiring the patient to do more procedures and to have fluid in the peritoneal cavity for at least part of the day.

- b. **Increasing frequency of cycles.** In general, doing more frequent cycles with APD increases clearances because it maximizes the concentration gradient between blood and dialysate (Perez, 2000; Demetriou, 2006). However, when the number of cycles exceeds 6–9 per 9-hour treatment, a large proportion of the dialysis session is spent draining and filling, and further increment in clearance becomes minimal. The benefit of more frequent cycles tends to be higher in high transporters and is higher for urea than for creatinine. It may also be influenced by catheter function. Maintaining a small amount of dialysate in the peritoneum constantly (i.e., using tidal PD) can be used to help support clearance during rapid cycling.
 - c. **Increase dwell volumes on cycles.** This increases clearance in APD, just as in CAPD. Because patients are supine during cycling, they can usually tolerate larger dwell volumes more easily. Greater clearances will be achieved if the same total amount of dialysis solution is delivered in a smaller number of aliquots (i.e., 4×2.5 L per session is better than 5×2 L per session) though the increase is modest.
 - d. **Time on cycles.** In general, the longer the time the patient spends on APD, the better the clearance because individual dwell times are longer, allowing more complete equilibration between dialysate and blood.
 - e. **Increasing dialysis solution tonicity.** As in CAPD, clearance can be augmented in APD by increasing daytime or nighttime ultrafiltration, but concerns about glucose-related complications limit the usefulness of this approach.
- E. **Incremental versus maximal prescription.** There are two distinct approaches to prescription of peritoneal dialysis when clearance targets are being considered. The incremental approach, which is particularly suitable when dialysis is being initiated early, suggests that peritoneal dialysis should be used to make up the difference between residual renal clearances and targeted clearances (Viglino, 2008). Thus, patients may initially require only two or three CAPD exchanges daily or a low-volume, day dry APD prescription or even a day-per-week-off dialysis. The alternative is the so-called maximal approach in which patients are at the outset given a sufficient prescription to meet their targets with peritoneal dialysis alone. This approach considers residual renal function as a temporary bonus that inevitably deteriorates with time.

The advantages of the incremental approach are that it is initially less costly and less onerous for the patient, and it may decrease total glucose exposure and risk of peritonitis, insofar as fewer procedures are required. A disadvantage is that it requires regular monitoring of residual function to ensure that the total clearance achieved does not fall below target levels.

- F. **Empirical versus modeled approach.** Another decision when prescribing peritoneal dialysis is whether to use commercially available software programs for modeling appropriate prescriptions or whether to proceed in an empirical manner. The modeled approach involves collecting patient anthropometric data, measuring peritoneal transport with a PET, and quantifying residual renal function. It also typically involves collection of 24-hour

dialysate effluent to make particular calculations about peritoneal fluid removal and absorption. The computer program uses the data to predict, with reasonable accuracy, the clearances that will be achieved with various potential prescriptions. The program can also suggest appropriate prescriptions to achieve the desired clearances. With this approach, the actual clearances still have to be measured as there is sometimes a discrepancy between the modeled and actual clearances achieved.

The alternative approach is empirical, in which the physician uses the knowledge of the patient's size, residual renal function, and peritoneal transport status to choose a reasonable prescription. This is then tested, clearances are assessed, and the prescription is adjusted if necessary. The modeled approach has the advantage that it may involve less trial and error and so results in earlier identification of an appropriate prescription for the patient, with consequent decreases in cost as well as inconvenience to the patient. The empirical method has a theoretical advantage that it focuses the physician's attention on the patient rather than on purely numerical data. In practice, a combination of both approaches is frequently used, with the modeled approach being of particular use in complex cases and in patients on APD.

- G. **Prescription pitfalls in peritoneal dialysis.** There are a number of common pitfalls that physicians face in attempting to achieve adequate clearances and fluid removal on peritoneal dialysis.
1. **Loss of residual renal function.** A common problem is that residual renal function is not monitored closely enough and drops to a very low level without the physician being aware. Thus, the patient is left on an inadequate prescription for a significant period of time. This is best avoided by measuring residual clearance every 2–3 months or by adopting a maximal prescription approach that gives sufficient peritoneal clearance independent of residual function.
 2. **Noncompliance.** A chronic peritoneal dialysis patient may sometimes appear uremic or have unexpectedly high levels of urea and potassium in blood despite measured clearances that exceed recommended targets. A strong possibility here is noncompliance. On the day that collections are performed, the patient is fully compliant with the prescription and appears to have excellent clearances. On other days, however, the patient is omitting exchanges or shortening time on the cyclor. There is no single test that identifies this particular problem, and a high index of suspicion is required. Serial measurements of 24-hour dialysate plus urinary creatinine excretion may help identify the problem. Patients in whom the total creatinine excretion has increased in comparison with a baseline value should be suspected of noncompliance. The rationale here is that on the day of the collection, creatinine that has accumulated on previous noncompliant days is being dialyzed out, giving an artificially high value. The alternative explanation for an increase in total creatinine excretion is a gain in lean body mass, but this does not often occur in chronic dialysis patients. There are a number of patterns of noncompliance in peritoneal dialysis patients that should be borne in mind (Bernardini, 2000). These include:
 - a. Skipping CAPD exchanges
 - b. Inadequate spacing of CAPD exchanges
 - c. Reducing the dwell volume of CAPD exchanges by flushing fresh dialysis solution

directly into the drain bag

- d. Skipping cycler treatments
 - e. Shortening of cycler time in APD
 - f. Skipping or shortening day dwells in APD
3. **High serum creatinine despite good clearances.** This is a common scenario. The patient has a Kt/V urea above 1.7 per week, but the serum creatinine is over 12–16 mg/dL (about 1,000–1,500 $\mu\text{mol/L}$). There are a number of possibilities here. One is noncompliance with the prescription. If this is the case, blood urea and potassium may also be high. A second possibility is that this is an example of discordance between Kt/V , which is high, and CrCl , which is low. This is most often seen once residual renal function fades away in low-transport patients or in those on APD with no day dwell. This can be confirmed by measuring the CrCl . The third possibility, also common, is that the serum creatinine is markedly elevated, not because of particularly low clearance, but rather because of high creatinine generation, indicating a higher percentage of lean body mass. This can be demonstrated by measuring CrCl and showing it to be at or above 45–50 L per week per 1.73 m^2 and by showing that percentage of lean body mass is high relative to what might be predicted. Such patients are not necessarily overtly muscular and indeed may be somewhat thin. Identification of this situation is helpful because patients with high creatinine generation or percentage of lean body mass have a good prognosis on PD, and it would be a mistake for the elevated serum creatinine to trigger a diagnosis of inadequate clearance and a switch to hemodialysis.
4. **Day dry APD in anuric patients.** Some patients, even when their residual function is lost, can achieve a Kt/V urea above 1.7 per week with prescriptions that leave them “dry” for all or most of the day. Such patients are typically smaller in body size and are high or high-average transporters. This creates a concern because while Kt/V is above target, middle-molecule clearance in the absence of residual function is dependent on dialysis time and so, while not routinely measured, will be low. There is no recommended target for middle-molecule clearance in either peritoneal or hemodialysis and no high-level clinical evidence that middle-molecule clearance is important. However, there has always been a viewpoint that it may matter and that middle-molecule clearance may be better in CAPD or APD with day dwells because they are continuous modalities compared to day dry APD. There is no definite answer to this question, but it should at least be kept in mind when prescribing “day dry” APD in anuric patients.
5. **Inappropriate switch from CAPD to APD.** It is sometimes presumed that APD is a panacea for inadequate dialysis on CAPD, but the problem can actually become worse on APD if prescriptions are inappropriate. This is especially true in low transporters, who are unlikely to achieve higher clearances on APD than on CAPD, unless two day dwells are prescribed. Also, a patient who has the same Kt/V urea after a switch from CAPD to APD will have a lower CrCl .
6. **Inadequate attention to fluid removal.** Fluid removal is frequently neglected in prescriptions for peritoneal dialysis. Prescriptions that yield good clearances may not give sufficient ultrafiltration to control volume status and keep the patient free from hypertension. This

is particularly true in high and high-average transporters, especially if long dwells which result in net fluid resorption are used. The use of icodextrin for the long dwell in both CAPD and APD and the prescription of short day dwells in APD are two strategies that may be useful.

III. **GLUCOSE-SPARING STRATEGIES.** In the past decade, there has been increasing concern about the harmful consequences of exposure to the hypertonic glucose in peritoneal dialysis solutions (Holmes, 2006). There is strong evidence that cumulative glucose exposure leads to deterioration in membrane function with a decline in ultrafiltration. There is also awareness that systemic absorption of glucose may aggravate or induce hyperglycemia, hyperinsulinemia, obesity, and hyperlipidemia. Glucose-sparing strategies can be divided into the following categories:

- A. **General strategies.** These are approaches to lessen the need for high amounts of ultrafiltration and so for hypertonic glucose. They include (1) salt and water restriction; (2) prescription of high-dose loop diuretics to maintain higher urine volumes; (3) any intervention that preserves residual renal function (angiotensin-converting enzyme inhibitors or angiotensin receptor blockers, avoidance of nephrotoxic medications, contrast exposure, and volume depletion); and (4) revising target weight upward to avoid inappropriate use of hypertonic glucose when body weight gain occurs due to increase in body fat mass.
- B. **Non-glucose dialysis solution strategies.** These involve the substitution of dialysis solutions containing icodextrin or amino acids for those containing glucose (Paniagua, 2009; Li, 2013).

While avoidance of hypertonic glucose is central to glucose-sparing strategies, a balance needs to be kept between minimizing excess glucose exposure and avoiding hypervolemia.

IV. **NUTRITIONAL ISSUES IN PERITONEAL DIALYSIS.** Nutritional status in peritoneal dialysis patients has been repeatedly shown to predict patient survival and other outcomes. It is recommended that indicators of nutrition be routinely monitored to identify high-risk patients and target them for appropriate interventions.

A. **Nutritional indices**

- 1. **Normalized protein nitrogen appearance (nPNA).** This is easily measured using the same 24-hour collections of dialysate and urine as are used to calculate Kt/V . The rationale is that, in steady state, nitrogen excretion is proportional to protein intake. A variety of formulas have been derived to estimate nPNA from nitrogen and protein excretion. One reliable formula is that developed by Bergström (1998) (see Table 25.5 for formula and sample calculation). Previously, PNA estimates were normalized to actual body weight, but this can lead to misleadingly high nPNA values in wasted malnourished patients and to inappropriately low values in obese patients (Harty, 1994). Normalization to desirable or ideal weight based on anthropometric tables is now preferred. Recommended target nPNA for peritoneal dialysis patients is 1.2 g/kg per day, but this may be unnecessarily high for many patients who often can achieve nitrogen balance at lower intakes. A falling nPNA or a level less than 0.8 g/kg per day

should be a cause for concern, especially if accompanied by other evidence of poor nutrition.

TABLE

25.5

Calculation of Normalized Protein Nitrogen Appearance with Example

Bergström formulas:

$$1. \text{ PNA (g/d)} = 20.1 + 7.5 \text{ UNA (g/d)}$$

or

$$2. \text{ PNA (g/d)} = 15.1 + 6.95 \text{ UNA (g/d)} + \text{dialysate protein losses (g/d)}$$

$$\text{UNA (g/d)} = \text{urinary urea losses (g/d)} + \text{dialysate urea losses (g/d)}$$

Use formula (1) if dialysate protein losses are unknown and formula (2) if they are known.

Normalization of PNA to body weight gives nPNA. Actual body weight, if used, can give a misleadingly high value in malnourished patients and a misleadingly low one in obese patients.

Normalization to standard body weight based on anthropometric tables is preferable.

Example:

A 60-kg man on CAPD 4×2.5 L daily has 24-hr dialysate effluent volume of 12 L which contains 58.3 mg/dL urea nitrogen so that total content = $12 \times 58.3 \times 10 = 7,000$ mg = 7 g of urea nitrogen.

The 24-hr urine has a 500-mL volume and contains 560 mg/dL = 2,800 mg = 2.8 g of urea nitrogen.

Total UNA = $7 + 2.8 = 9.8$ g/d.

Dialysate protein losses are measured at 8 g/d.

Thus;

$$\text{PNA} = 15.1 + 6.95 (9.8) + 8 = 91.2 \text{ g/d.}$$

$$\text{nPNA based on actual weight} = 91.2/60 = 1.52 \text{ g/kg/d.}$$

Patient has lost weight, however, and anthropometric tables suggest that his standard weight is 72 kg.

$$\text{nPNA based on this weight} = 91.2/72 = 1.27 \text{ g/kg/d}$$

UNA, urea nitrogen appearance; PNA, protein nitrogen appearance.

2. **Caloric intake.** This is sometimes neglected in dialysis patients because it cannot be as easily measured as protein intake. In peritoneal dialysis, caloric intake is a combination of dietary intake plus calories in the glucose absorbed from the dialysis solution.

The suggested target is 35 kcal/kg per day; typically, 10% to 30% of this will come from dialysis solution glucose, with the exact amount absorbed depending on solution tonicity, dwell time, and volume of solution used, as well as on the patient's PET characteristics, which influence the percentage of instilled glucose absorbed. Measurement of energy intake requires dietary assessment plus quantification of the glucose absorbed. The latter can be calculated directly by subtracting the amount of glucose in the effluent from the amount present in the source dialysis solution.

3. **Serum albumin.** This is one of the strongest predictors of patient survival on peritoneal dialysis. Serum albumin in this population is much more than a nutritional marker, as it

is influenced by peritoneal transport status, which influences dialysate albumin losses, and by the presence of systemic illness or inflammation, as judged by the serum levels of acute-phase reactants such as C-reactive protein (Yeun, 1997). Compared with the above factors, dietary protein intake has only a minor effect on serum albumin.

4. **Subjective global assessment (SGA).** This simple clinical tool is easily done at the bedside, promotes history taking and physical examination, and has been shown to predict patient outcome. The subjective global assessment is described in detail in Chapter 31.
 5. **Creatinine excretion.** The total creatinine content measured in the same 24-hour urine and dialysate collections done to calculate clearance can be used to estimate lean body mass (Keshaviah, 1995). These estimates of creatinine excretion are predictive of patient outcome, and a low or falling value identifies a patient who is at risk.
- B. Treatment of malnutrition.** This is reviewed in detail in Chapter 31.
1. **Amino acid-containing dialysis solution.** Intraperitoneal amino acids have long been studied and are available in many countries, though not in the United States. They are typically administered as one 2-L dwell given during the daytime either on CAPD or on APD, using the “last bag option.” About 85% of the amino acid content of the bag will be absorbed if it is left in place for 6 hours. Food should be ingested at the time of the dwell to maximize utilization of the absorbed amino acids. This strategy does improve nitrogen balance but there is little evidence of a dramatic effect on important clinical outcomes. The best randomized study to date suggests that intraperitoneal amino acids are associated with better long-term maintenance of nutritional indices, particularly in women, but no study has been large enough to detect any beneficial effect on quality or quantity of life (Li, 2003a).

References and Suggested Readings

- Bergström J, et al. Calculation of the protein equivalent of total nitrogen appearance from urea appearance: which formulas should be used? *Perit Dial Int.* 1998;18: 467–473.
- Bernardini J, et al. Pattern of noncompliance with dialysis exchanges in peritoneal dialysis patients. *Am J Kidney Dis.* 2000;35:1104–1110.
- Blake PG, et al. Recommended clinical practices for maximizing peritoneal clearances. *Perit Dial Int.* 1996;16:448–456.
- Blake PG, et al; CSN Workgroup on Peritoneal Dialysis Adequacy. Clinical practice guidelines and recommendations on peritoneal dialysis adequacy 2011. *Perit Dial Int.* 2011;31:218–239.
- Churchill DN, et al. Adequacy of dialysis and nutrition in continuous peritoneal dialysis [The CANUSA study]. *J Am Soc Nephrol.* 1995;7:198–207.
- De Fijter CW, et al. Clinical efficacy and morbidity associated with CCPD rather than CAPD. *Ann Intern Med.* 1994;120:264–271.
- Demetriou D, et al. Adequacy of automated peritoneal dialysis with and without manual daytime exchange. *Kidney Int.* 2006;70:1649–1655.
- Diaz-Buxo JA. Enhancement of peritoneal dialysis: the “PD Plus” concept. *Am J Kidney Dis.* 1996;27:92–98.
- Dombros N, et al. European Best Practice Guidelines for Peritoneal Dialysis. 7. Adequacy of

- peritoneal dialysis. *Nephrol Dial Transplant*. 2005;20(suppl 9):24–27.
- Durand PY. APD schedules and clinical results. *Contrib Nephrol*. 2003;140:272–277.
- Fernando SK, et al. Tidal PD: its role in the current practice of peritoneal dialysis. *Kidney Int Suppl*. 2006;103:S91–S95.
- Guest S. Intermittent peritoneal dialysis: urea kinetic modeling and implications of residual kidney function. *Perit Dial Int*. 2012;32:142–148.
- Harty JC, et al. The normalized protein catabolic rate is a flawed marker of nutrition in CAPD patients. *Kidney Int*. 1994;45:103–109.
- Holmes C, et al. Glucose sparing in peritoneal dialysis: implications and metrics. *Kidney Int Suppl*. 2006;103:S104–S109.
- Johansen KL, et al. Anabolic effects of nandrolone decanoate in patients receiving dialysis: a randomized controlled trial. *JAMA*. 1999;281:1275–1281.
- Keshaviah PR, et al. The peak concentration hypothesis: a urea kinetic approach to comparing the adequacy of continuous ambulatory peritoneal dialysis and hemodialysis. *Perit Dial Int*. 1989;9:257–260.
- Keshaviah PR, et al. Lean body mass estimation by creatinine kinetics. *J Am Soc Nephrol*. 1995;4:1475–1485.
- Li FK, et al. A 3 year prospective randomized controlled study on amino acid dialysate in patients on CAPD. *Am J Kidney Dis*. 2003a;42:173–183.
- Li PK, et al. Effects of an ACEI on residual renal function in patients receiving CAPD: a randomized controlled trial. *Ann Intern Med*. 2003b;139:105–112.
- Li PK, et al. Randomized controlled trial of glucose sparing peritoneal dialysis in diabetic patients. *J Am Soc Nephrol*. 2013;24:1889–1900.
- Lo WK, et al. Effect of Kt/V on survival and clinical outcome in CAPD patients in a randomized prospective study. *Kidney Int*. 2003;64:649–656.
- Paniagua R, et al. Effect of increased peritoneal clearance on mortality rates in peritoneal dialysis: ADEMEX, a prospective randomized controlled trial. *J Am Soc Nephrol*. 2002;13:1307–1320.
- Paniagua R, et al. Icodextrin improves fluid and metabolic management in high and high-average transport patients. *Perit Dial Int*. 2009;29:42–32.
- Paniagua R, et al. Ultrafiltration and dialysis adequacy with various daily schedules of dialysis fluids. *Perit Dial Int*. 2012;32:545–551.
- Perez RA, et al. What is the optimal frequency of cycling in APD? *Perit Dial Int*. 2000;20:548–556.
- Sarkar S, et al. Tolerance of large exchange volumes by peritoneal dialysis patients. *Am J Kidney Dis*. 1999;33:1136–1141.
- Rodriguez-Carmona A, et al. Compared time profiles of ultrafiltration, sodium removal and renal function in incident CAPD and APD patients. *Am J Kidney Dis*. 2004;44:132–145.
- Viglino G, et al. Incremental peritoneal dialysis: effects on the choice of dialysis modality, residual renal function and adequacy. *Kidney Int Suppl*. 2008;108:S52–S55.
- Virga G, et al. A load volume suitable for reaching dialysis adequacy targets in anuric patients on 4-exchange CAPD. *J Nephrol*. 2014;27:209–215.
- Woodrow G, et al. Comparison of icodextrin and glucose solutions for daytime dwell in APD. *Nephrol Dial Transplant*. 1999;14:1530–1535.
- Yeun JY, et al. Acute phase proteins and peritoneal dialysate albumin loss are the main determinants

of serum albumin in peritoneal dialysis patients. *Am J Kidney Dis.* 1997;30:923–927.

Fluid overload in peritoneal dialysis (PD) patients can manifest as generalized edema, pulmonary edema, and hypertension. It contributes to left ventricular hypertrophy and is a major contributor to cardiovascular disease, the leading cause of death in all dialysis patients. It is also associated with hypoalbuminemia, malnutrition, inflammation, and atherosclerosis (Demirci, 2011); and it is a significant cause of technique failure, especially in long-term PD patients (Woodrow, 2011).

I. ASSESSMENT OF FLUID STATUS. This is based primarily on clinical examination, which gives at best a crude estimation. The target body weight or “dry weight” for PD is that weight which gives a well-tolerated normotensive, edema-free state, and, just as in hemodialysis, it is determined by trial and error. Since PD patients tend to be seen less frequently than those on hemodialysis, there is a risk that this process will be more protracted and less well done. It requires frequent clinical reassessment of patients.

Alternative methods of assessing volume status include bioimpedance, serum levels of brain natriuretic peptide (BNP), and ultrasound of the inferior cava or of the lungs. Bioimpedance analysis can be done with relatively simple devices and involves attachment of electrodes and application of low-voltage currents. This allows extracellular and intracellular fluid volumes to be estimated. It is being used clinically in some centers but without high-grade evidence to justify it (John, 2010). Serum BNP levels are in clinical use and are predictive of patient outcomes, but do not reliably distinguish fluid overload from cardiac injury (Granja, 2007; Wang, 2007).

II. MECHANISMS OF FLUID OVERLOAD. Fluid overload in a PD patient may reflect any combination of inappropriate prescription, noncompliance, loss of residual renal function, mechanical problems, and peritoneal membrane dysfunction. Awareness that any one factor alone may not explain an individual PD patient’s volume overload is important and one should avoid thoughtlessly attributing all fluid overload to membrane-related ultrafiltration failure (UFF).

III. DIAGNOSIS OF PERITONEAL MEMBRANE DYSFUNCTION AND ULTRAFILTRATION FAILURE. UFF is defined as fluid overload in association with an ultrafiltration volume <400 mL in a modified peritoneal equilibration test (PET) (Ho-dac-Pannakeet, 1997). The modified PET uses a 4.25% dialysate dwell instead of the usual 2.5% bag used in the standard PET (described in Chapter 21). UFF should not be diagnosed if the ultrafiltration volume exceeds 400 mL or if there is no clinical evidence of significant volume overload. *UFF should not be diagnosed until catheter malfunction and leaks have been excluded.* An ultrafiltration volume >400 mL in the modified

PET implies normal peritoneal membrane function, and if fluid overload is present, closer attention needs to be paid to nonmembrane causes as listed in Table 26.1.

If UFF is diagnosed, the next step is to review the solute transport characteristics of the patient using the results of the modified 4.25% PET (or the standard PET as the results are very similar).

- A. **High transporter with UFF (type I).** In this situation, the dialysate dextrose concentration falls quickly after infusion because of rapid absorption, resulting in loss of the concentration gradient that drives fluid removal. This is the most common cause and is often called type I UFF. It typically develops after 3 or more years on PD. It is believed to reflect an increase in the effective peritoneal surface area consequent to the increased membrane vascularity that occurs with time on PD. This occurs to a greater extent in some patients than in others. The contribution of interstitial fibrosis and resultant thickening of the membrane is increasingly recognized (Davies, 2005). Causes of type I UFF include cumulative exposure of the membrane to high glucose loads (Davies, 2001) and perhaps to other bioincompatible features of PD solutions, including low pH, lactate, and toxic glucose degradation products. Other causes may be related to cumulative episodes of peritonitis or to systemic inflammation seen in uremia generally. Type I UFF may also occur transiently in some patients with acute peritonitis who have a temporary increase in transport status during and after the episode owing to acute inflammation of the membrane.

TABLE

26.1

Causes of Fluid Overload in PD Patients

Inappropriate bag selection
Inappropriate prescription for membrane transport status
 Long, dextrose-containing daytime or nocturnal dwells
 Failure to optimize APD regimen for transport status
 Failure to use icodextrin-containing solutions
Noncompliance with PD prescription
Noncompliance with salt and water restriction
Loss of residual renal function
Abdominal leak
Catheter malfunction
Poor blood glucose control
Peritoneal membrane dysfunction

- B. **Low transporter with UFF (type II).** This group of patients has reduced small solute clearance and reduced fluid removal. This is also called type II UFF and is much less common. It reflects decreased membrane surface area and is most often due to adhesions and scarring after a severe peritonitis or other intra-abdominal complication. It is difficult to maintain these patients on PD unless they have significant residual renal function.

C. **UFF with transport in the normal range (usually high-average and low-average transporters).** Careful consideration once again should be made to exclude mechanical causes for poor fluid removal in this group.

1. Increased lymphatic absorption of peritoneal fluid is the cause in some patients and this is called **type III UFF**. Lymphatic absorption can be quantified by measuring the disappearance rate of dextran 70 from the peritoneal cavity, but this is rarely done in clinical practice, and the diagnosis tends to be one of exclusion.
2. **Aquaporin deficiency.** A similar pattern can be seen with the interesting but rarer condition of aquaporin deficiency. This can be diagnosed by measuring the change in dialysate sodium concentration after 30–60 minutes of a 2-L dialysis dwell with 4.25% dextrose compared with a 2-L dwell using 1.5% dextrose. Why does the dialysate sodium fall during the early part of a dwell? When dialysate glucose levels are high, osmotically driven UF occurs primarily via aquaporin channels, which transport water but not sodium. The result is an early lowering in the dialysate sodium concentration by 5–10 mmol/L with a 4.25% glucose dwell. This leads to a sodium gradient between blood and dialysate, and sodium diffusion brings the dialysate sodium level up again as the dwell proceeds (Fig. 21.7). If aquaporin-mediated water transport is impaired, the initial fall in dialysate sodium will not occur with 4.25% dwells and there will be a <5 mmol/L difference between the dialysate sodium levels at 30–60 minutes with the 4.25% dwell compared with the 1.5% dwell (Smit, 2004; Ni, 2006).

IV. **PREVENTION AND MANAGEMENT OF FLUID OVERLOAD.** Often, multiple causes of volume overload coexist in an individual PD patient. For example, there may be some UFF but also excess dietary salt intake or poor glucose control. Optimal management may therefore require multiple therapeutic and preventive strategies.

A. **General measures**

1. **Sodium restriction.** It is important that patients receive education on sodium and fluid restriction, especially when residual renal function declines. An intake of <100 mmol (2.3 g) of sodium per day is recommended for those with difficult hypertension or volume control problems (Ates, 2001).
2. **Patient education on when to use higher-strength glucose solutions.** Patients are usually taught to choose or titrate PD solution dextrose concentrations in order to achieve target body weight. Underuse of hypertonic solutions may contribute to fluid overload. However, regular selection of high-concentration dextrose solutions should not be the preferred method of fluid volume control over sodium restriction. Overuse of the high-concentration dextrose solutions may adversely affect peritoneal membrane function, increasing glucose absorption, worsening blood sugar and lipid control, and promoting obesity.
3. **Frequent clinical assessment.** Patients need to be assessed regularly and have their target weight reviewed. In PD patients, there is an early tendency to weight gain, likely due to glucose absorption, and so target weight may need to be adjusted to avoid excess use of hypertonic glucose in an attempt to reach an unrealistic weight. Later in the course of PD, as urine volume declines there is an increased rate of fluid overload,

and the clinician needs to be aware of this and intervene accordingly. No single test is reliable to detect this, and clinical examination plus trial and error remains the best approach.

4. **Good blood sugar control.** This will help maintain the glucose concentration gradient across the peritoneal membrane required for fluid removal.
5. **Preserving residual renal function.** This is important for both clearance and fluid removal. There is clinical trial evidence in PD patients that angiotensin-converting enzyme inhibitors and angiotensin receptor blockers preserve residual renal function, in terms of both clearance and urine volume. Use of high-dose loop diuretics in patients with residual renal function, with or without metolazone, will also increase urine volume and sodium and fluid removal. Avoidance of nephrotoxins and intravascular depletion both serve to protect residual renal function. Biocompatible PD solutions based on multipouched bag technology have low glucose degradation product content, and some randomized trials suggest that these are associated with better preservation of residual renal function (Johnson, 2012); however, there is a concern that this is, at least partly, mediated by less ultrafiltration with these solutions (Blake, 2012).
6. **Abdominal leaks.** See Chapter 28.
7. **Catheter malfunction.** See Chapter 23.
8. **Preservation of peritoneal membrane function.** Reduction in episodes of peritonitis and avoidance of excessive exposure to high-dextrose-concentration PD fluid will help to preserve long-term peritoneal membrane function. Randomized trials looking at “biocompatible” PD solutions with low glucose degradation product levels have not shown evidence that these solutions preserve membrane function better than when conventional PD solutions are used.

B. Management of UFF

1. **High transport status (UFF type I).** Short dwell times are required to maintain the dialysate dextrose concentration gradient and so automated peritoneal dialysis (APD), programmed for short 1–1.5 hour dwells, may be best. Long-duration dextrose-containing dwells in continuous ambulatory peritoneal dialysis (CAPD) and APD must be avoided. In APD, short dextrose day dwells can be used. However, icodextrin is a more attractive approach for long dwells in both CAPD and APD.
 - a. **Icodextrin.** This is a carbohydrate polymer used instead of dextrose, to produce a concentration gradient for ultrafiltration. It is not absorbed across the membrane, although it does slowly get taken up in the lymphatics. Accordingly, a concentration gradient is maintained throughout a long dwell, allowing ongoing ultrafiltration. Icodextrin is ideal for the 14–16-hour day dwell in APD and for the long nocturnal dwell in CAPD. Use of icodextrin has been shown to improve volume status (Davies, 2003) and to prolong technique survival substantially in patients with UFF and high transport status (Takatori, 2011). Its use has also been shown to reduce the extracellular fluid-to-intracellular fluid ratio as measured by bioimpedance (Woodrow, 2004).
 - b. **Resting the peritoneum.** There have been documented cases of improved peritoneal membrane function in type I UFF following a temporary cessation of

PD. The mechanism for this is unclear but may involve resolution of increased vascularity with time off PD.

2. **UFF with low transport status.** These patients are unlikely to do much better on APD or with icodextrin. Generally, transfer to hemodialysis is required.
3. **UFF with average transport status.** There is no specific method to either reduce lymphatic absorption or to correct impaired aquaporin function. Generally, this type of UFF is managed by salt and water restriction, diuretics, and general measures to increase total ultrafiltration to compensate for the volume reabsorbed. This approach may include shortening dwell times and using icodextrin for long dwells. Icodextrin may be particularly useful in aquaporin deficiency as the ultrafiltration it induces occurs almost exclusively via nonaquaporin channels (La Milia, 2006).

V. **GLUCOSE-SPARING STRATEGIES.** At the level of the peritoneal membrane, there has been evidence from laboratory studies that hypertonic glucose exposure leads to neovascularization of the membrane and a pattern analogous to UFF with high transport status. Clinical studies have now shown that long-term PD patients exposed to more hypertonic glucose are more likely to develop high transport characteristics than those who receive less glucose (Davies, 2001). Systemically, glucose loading may also be harmful as detailed in Chapter 29. This has led to a greater emphasis on strategies to minimize glucose exposure. Essentially, this involves the use of less hypertonic glucose (Johnson, 2012; Li, 2013). At first, such an approach might be expected to lead to less ultrafiltration and to a greater risk of fluid overload. It is possible, however, to find a balance between glucose sparing and volume control. Effective glucose-sparing strategies include salt and water restriction, the use of loop diuretics to maintain volume, and the use of renin angiotensin system inhibitors to preserve residual renal function. Icodextrin allows the reduction of daily glucose exposure, and there are studies suggesting more stable long-term membrane function with this solution (Davies, 2005). Intraperitoneal amino acids can also be substituted for one daily dextrose dwell.

VI. HYPERTENSION AND HYPOTENSION IN PD

A. **Hypertension.** PD was initially advocated as providing better blood pressure control than hemodialysis because of its continuous nature. This was certainly demonstrated in early reports on PD populations. More recently, it has been demonstrated that antihypertensive medication requirements increase with duration on PD, especially when residual renal function is lost (Ortega, 2011).

1. **Sodium removal and hypertension using APD.** Sodium removal is a little less in APD because the short duration of the cycled dwells means that dialysate is drained while sodium levels are still low due to sodium sieving and before sodium diffusion has had a chance to correct this (Rodriguez-Carmona, 2004). Concerns have been raised, but studies to date have not consistently shown a difference in blood pressure control between patients on CAPD and APD (Boudville, 2007).
2. **Management.** This should focus initially on volume control. Antihypertensives, other than cardioprotective agents, should only be introduced if this approach has been unsuccessful. Preference should be given to agents that have a beneficial effect on urine

volume or residual renal function, such as loop diuretics, angiotensin-converting enzyme inhibitors, and angiotensin receptor blockers. The choice of agent in many patients may be driven by coexisting medical conditions such as ischemic heart disease.

- B. **Hypotension.** Hypotension is not uncommon in PD populations, with one cohort study (Malliaras, 2002) detecting it in 13% of patients. The cause of hypotension is sometimes unclear, but approximately 20% of cases are secondary to heart failure. An additional 40% may be due to hypovolemia, and it is important to recognize this as hypotension in these patients typically responds to volume repletion and residual renal function may improve as well. Patients with hypotension due to cardiac causes and cases in which no cause can be identified have a poor prognosis, with a high early mortality rate. Agents such as midodrine and fludrocortisone have been used but with no proven long-term benefit. New onset hypotension may, of course, represent developing sepsis or acute cardiac injury.

References and Suggested Readings

- Ates K, et al. Effect of fluid and sodium removal on mortality in peritoneal dialysis patients. *Kidney Int.* 2001;60:767–776.
- Blake PG. Balance about balANZ. *Perit Dial Int.* 2012;32:493–496.
- Boudville NC, et al. Blood pressure, volume, and sodium control in an automated peritoneal dialysis population. *Perit Dial Int.* 2007;27:537–543.
- Davies SJ, et al. Peritoneal glucose exposure and changes in membrane solute transport with time on peritoneal dialysis. *J Am Soc Nephrol.* 2001;12:1046–1051.
- Davies SJ, et al. Icodextrin improves the fluid status of peritoneal dialysis patients: results of a double-blind randomized controlled trial. *J Am Soc Nephrol.* 2003;14:2338–2344.
- Davies SJ, et al. Longitudinal membrane function in functionally anuric patients treated with APD: data from EAPOS on the effects of glucose and icodextrin prescription. *Kidney Int.* 2005;67:1609–1615.
- Demirci MS, et al. Relation between malnutrition inflammation atherosclerosis and volume status: the usefulness of bioimpedance in peritoneal dialysis patients. *Nephrol Dial Transplant.* 2011;26:1708–1716.
- Granja CA, et al. Brain natriuretic peptide and impedance cardiography to assess volume status in peritoneal dialysis patients. *Adv Perit Dial.* 2007;23:155–160.
- Ho-dac-Pannakeet MM, et al. Analysis of ultrafiltration failure in peritoneal dialysis patients by means of standard peritoneal permeability analysis. *Perit Dial Int.* 1997;17:144–150.
- John B, et al. Plasma volume, albumin and fluid status in peritoneal dialysis patients. *Clin J Am Soc Nephrol.* 2010;5:1463–1470.
- Johnson DW, et al. Effects of biocompatible versus standard fluid on peritoneal dialysis outcomes. *J Am Soc Nephrol.* 2012;23:1097–1107.
- La Milia V. Sodium kinetics in peritoneal dialysis: from theory to clinical practice. *G Ital Nefrol.* 2006;23:37–48.
- Lee JA, et al. Association between serum n-terminal pro-brain natriuretic peptide concentration and left ventricular dysfunction and extracellular water in continuous ambulatory peritoneal dialysis patients. *Perit Dial Int.* 2006;26:360–365.

- Li PK, et al. Effects of an angiotensin-converting enzyme inhibitor on residual renal function in patients receiving peritoneal dialysis: a randomized, controlled study. *Ann Int Med.* 2003;139:105–112.
- Li PK, et al. Randomized controlled trial of glucose-sparing peritoneal dialysis in diabetic patients. *J Am Soc Nephrol.* 2013;24:1889–1900.
- Malliaras M, et al. Hypotension in patients on chronic peritoneal dialysis: etiology, management, and outcome. *Adv Perit Dial.* 2002;18:49–54.
- Mujais S, et al. Evaluation and management of ultrafiltration problems in peritoneal dialysis. International Society for Peritoneal Dialysis Ad Hoc Committee on Ultrafiltration Management in Peritoneal Dialysis. *Perit Dial Int.* 2000;20(suppl 4):S5–S21.
- Ni J, et al. Aquaporin-1 plays an essential role in water permeability and ultrafiltration during peritoneal dialysis. *Kidney Int.* 2006;69:1518–1525.
- Ortega LM, Materson BJ. Hypertension in peritoneal dialysis patients: epidemiology, pathogenesis and treatment. *J Am Soc Hypertens.* 2011;5:128–136.
- Paunuccio V, et al. Chest ultrasound and hidden lung congestion in peritoneal dialysis patients. *Nephrol Dial Transplant.* 2012;27:3601–3605.
- Rodriguez-Carmona A, et al. Compared time profiles of ultrafiltration, sodium removal and renal function in CAPD and APD patients. *Am J Kidney Dis.* 2004;44:132–145.
- Sharma AP, Blake PG. Should fluid removal be used as an index of adequacy in PD? *Perit Dial Int.* 2003;23:107–108.
- Smit W, et al. Quantification of free water transport in peritoneal dialysis. *Kidney Int.* 2004;66:849–854.
- Takatori Y, et al. Icodextrin increases technique survival rate in peritoneal dialysis patients with diabetic nephropathy by improving body fluid management: a randomized controlled trial. *Clin J Am Soc Nephrol.* 2011;6:1337–1344.
- Wang AY, et al. N-terminal pro-brain natriuretic peptide: an independent risk predictor of cardiovascular congestion, mortality, and adverse cardiovascular outcomes in chronic peritoneal dialysis patients. *J Am Soc Nephrol.* 2007;18:321–330.
- Woodrow G. Volume status in peritoneal dialysis patients. *Perit Dial Int.* 2011;31 (suppl 2):S77–S82.
- Woodrow G, et al. Abnormalities of body composition in peritoneal dialysis patients. *Perit Dial Int.* 2004;24:169–175.

I. PERITONITIS

A. **Incidence.** Peritonitis remains the Achilles' heel of peritoneal dialysis (PD). Peritonitis is a "contributing factor" to 16% of deaths on PD. Furthermore, it is the most common cause of treatment failure, accounting for nearly 30% of the cases. The overall incidence of peritonitis in continuous ambulatory peritoneal dialysis (CAPD) patients during the 1980s and early 1990s averaged 1.1–1.3 episodes per patient-year in the United States. With improved patient training, PD delivery systems, and prophylactic measures, the rate of peritonitis has fallen worldwide. Many centers now report a peritonitis rate of 0.2 to 0.6 episodes per patient-year at risk, or 1 episode per 20–60 patient-months of PD (Piraino, 2011). The introduction of Y-set and double-bag disconnect systems has substantially reduced the incidence of peritonitis, particularly episodes caused by gram-positive organisms (Monteon, 1998; Li, 2002). The same flush-before-fill methodology used in CAPD Y sets can also be used effectively in automated peritoneal dialysis (APD). Peritonitis rates with APD and CAPD are not generally different. Patients on APD going "dry" during the day (i.e., no daytime dwell) may have a decreased risk of infection compared with those with a day dwell. The current International Society for Peritoneal Dialysis recommendations on PD-related infections (Piraino, 2011) state that every program should monitor infection rates, ideally once a month, but, at a minimum, on a yearly basis.

B. Pathogenesis

1. Pathways of infection

- a. **Intraluminal.** Peritonitis occurs most often because of errors in technique in making or breaking a transfer set-to-bag or catheter-to-transfer set connection. This allows bacteria to gain access to the peritoneal cavity via the catheter lumen. Typically, the organisms involved are coagulase-negative staphylococci or diphtheroids.
- b. **Periluminal.** Bacteria present on the skin surface can enter the peritoneal cavity via the peritoneal catheter tract. Typically, the organisms involved are *Staphylococcus aureus* or *Pseudomonas aeruginosa*.
- c. **Bowel source.** Bacteria of intestinal origin can enter the peritoneal cavity by migrating across the bowel wall. This is the usual mechanism of peritonitis

episodes associated with diarrheal states and/or instrumentation of the colon, and may also be seen with strangulated hernia. Typical organisms involved are *Escherichia coli* and *Klebsiella* sp.

- d. **Hematogenous.** Less commonly, peritonitis is due to bacteria that have seeded the peritoneum from a distant site by way of the bloodstream. Typical organisms here are streptococci and staphylococci.
- e. **Transvaginal.** This is uncommon, but ascending infection may occur from the vagina via the uterine tubes into the peritoneum. Some *Candida* peritonitis may occur by this route.

2. **Role of host defenses.** The peritoneal leukocytes are critical in combating bacteria that have entered the peritoneal space by any of the routes already mentioned. A number of factors are now known to alter their efficacy in phagocytizing and killing invading bacteria.

- a. **Dialysis solution pH and osmolality.** Standard PD solutions have a pH around 5 and an osmolality ranging from 1.3 to 1.8 times that of normal plasma, depending on the glucose concentration used. These unphysiologic conditions may inhibit the ability of peritoneal leukocytes to phagocytize and kill bacteria. High osmolality, low pH, and the presence of the lactate anion combine to cause inhibition of superoxide. There is now some evidence that newer normal pH, “biocompatible” solutions may reduce the peritonitis rate, but this has not been a consistent finding among published studies (Cho, 2014).
- b. **Peritoneal dialysis solution calcium levels.** The antimicrobial actions of peritoneal macrophages are enhanced by both calcium and cholecalciferol. Use of active vitamin D has been reported to reduce the rate of peritonitis (Kerschbaum, 2013). Use of a 1.25-mM (2.5-mEq/L) calcium concentration in PD solution has gained popularity as it may improve adynamic bone disease and reduce vascular calcification. An increased risk of *Staphylococcus epidermidis* peritonitis has been reported with the use of low-calcium dialysis solutions (Piraino, 1992), but no subsequent confirmatory reports have been published.

C. **Etiology.** Using appropriate culture techniques, an organism can be isolated from the peritoneal fluid in over 90% of cases in which symptoms and signs of peritonitis and an elevated peritoneal fluid neutrophil count are present. The responsible pathogen is usually a bacterium, but fungal peritonitis occurs occasionally (Table 27.1).

TABLE

27.1

Frequency of Organisms Isolated in Patients with Peritonitis

Organisms Identified	Percentage(%)
Gram-positive organisms	40–50
<i>S. aureus</i>	11–12
Coagulase-negative staphylococcal species	12–30
Gram-negative organisms	20–30
<i>Pseudomonas</i> sp.	12–15

Fungi	2–4
Mycobacterium	~1
Polymicrobial growth	~10
Culture-negative	~15

D. **Diagnosis.** At least two of the following three findings should be present: (a) symptoms and signs of peritoneal inflammation, (b) cloudy peritoneal fluid with an elevated peritoneal fluid cell count ($>100/\text{mL}$) due predominantly ($>50\%$) to neutrophils, and (c) demonstration of bacteria in the peritoneal effluent by Gram stain or culture.

1. **Symptoms and signs.** The most common symptom is abdominal pain, but this is sometimes very mild. Others are nausea, vomiting, and diarrhea (Table 27.2). Sometimes, especially in the elderly, the only symptoms are a relatively sudden loss of residual renal function and postural hypotension. On the other hand, abdominal pain can be present in dialysis patients owing to nonperitonitis-related abdominal causes; in those starting dialysis after a failed transplant in whom steroid treatment has been stopped, abdominal pain due to adrenal insufficiency should be considered.

2. Peritoneal fluid

a. **Cloudiness of the fluid.** The peritoneal fluid generally becomes cloudy when the cell count exceeds $50\text{--}100/\text{mL}$ ($50\text{--}100 \times 10^6/\text{L}$). In most patients, sudden onset of cloudy fluid with appropriate abdominal symptoms is sufficient evidence of peritonitis to warrant initiation of antimicrobial therapy. However, cloudy peritoneal fluid may be due to other factors (e.g., fibrin, blood, or, rarely, malignancy or chyle) rather than to an increase in the white blood cell (WBC) count. Occasionally, fluid drained after a prolonged dwell period (such as after the daytime dwell in APD patients) appears cloudy in the absence of peritonitis. Conversely, a relatively translucent peritoneal fluid does not completely exclude peritonitis. Cloudy fluid has been reported with the use of calcium channel blockers, presumably because they increase triglyceride concentration in the peritoneal fluid (Ram, 2012).

TABLE

27.2

Symptoms and Signs of Peritonitis

Percentage(%)

Symptoms

Abdominal pain	95
Nausea and vomiting	30
Feverish sensation	30
Chills	20
Constipation or diarrhea	15

Signs

Cloudy peritoneal fluid	99
Abdominal tenderness	80
Rebound tenderness	10–50 ^a
Increased temperature	33
Blood leukocytosis	25

^a Highly variable, depending on the severity of infection and the amount of time elapsed between onset and medical evaluation.

- b. **Importance of performing a differential count of peritoneal fluid cells.** Peritonitis is usually associated with an increase in the absolute number and percentage of neutrophils in the peritoneal fluid. On some occasions, a high peritoneal fluid cell count causing cloudy fluid will be present owing to an increase in the number of peritoneal fluid monocytes or eosinophils (see what follows). Most such cases are not associated with peritonitis and do not require antimicrobial treatment. For this reason, one should perform a differential cell count on the peritoneal fluid sample. Prior to counting, the fluid is spun in a special centrifuge (e.g., Cytospin, Shandon, Inc., Pittsburgh, PA) and the sediment colored with Wright stain.
- c. **Obtaining the specimen**
 1. **CAPD patients.** After disconnecting the drain bag full of peritoneal effluent, the bag is inverted several times to mix its contents. A sample (7 mL) is aspirated from the port of the drain bag and transferred to a tube containing ethylenediamine tetraacetic acid (EDTA).
 2. **APD patients.** A representative cell count can be obtained easily from the daytime dwell by first draining the abdomen and taking the sample from the drainage bag. In those who are “day dry,” there may be some residual fluid present in the abdomen at the time the patient is seen. In these cases, the peritoneal fluid sample can be obtained directly via the peritoneal catheter. After careful cleaning of the catheter with povidone–iodine, a syringe is attached using meticulous sterile technique, and 2–3 mL of fluid in the catheter lumen is withdrawn and discarded. The peritoneal fluid sample (7 mL) is then withdrawn from the catheter using a second syringe. The sample is injected into a tube containing EDTA. If insufficient fluid is obtained in this manner, one can infuse 1 L or more of dialysis solution and drain the abdomen, obtaining a sample from the effluent. Although the absolute peritoneal fluid cell count will be lower in this diluted specimen, the differential count will be similar to that in a sample obtained directly via the catheter.
 3. **Storage time.** Morphologic identification of the various cell types can become quite difficult in effluent samples stored for more than 3–5 hours prior to injection into the EDTA-containing sample tube.
- d. **Peritoneal fluid cell counts in peritonitis.** The absolute peritoneal fluid cell count in CAPD patients is usually <50 and often <10 cells/mcL. In “day dry” APD patients, the normal cell count may be much higher, especially in specimens taken directly

via the catheter when the peritoneal fluid volume is small. Normally, the peritoneal white cells are mainly mononuclear (monocytes, macrophages, and occasional lymphocytes), and the percentage of neutrophils does not exceed 15%. A value $>50\%$ suggests peritonitis, while a value $>35\%$ should raise suspicion. The percentage of neutrophils is raised in fungal and even tuberculous peritonitis as well as in the more common bacterial peritonitis.

The percentage of neutrophils in the peritoneal fluid is occasionally elevated in the absence of peritonitis—in patients with infectious diarrhea or active colitis (or appendicitis or diverticulitis), in those with pelvic inflammatory disease, and in women who are menstruating or ovulating or who have recently had a pelvic examination.

- e. **Peritoneal fluid monocytosis.** If there is persistent peritoneal fluid monocytosis or lymphocytosis, tuberculous peritonitis should be considered. Peritoneal fluid monocytosis may also occur in conjunction with peritoneal fluid eosinophilia.
- f. **Peritoneal fluid eosinophilia.** The peritoneal fluid eosinophil count may become elevated in PD patients, causing cloudy fluid and leading to a suspicion of peritonitis (Humayun, 1981). Usually, the peritoneal fluid monocyte count is also elevated. Peritoneal fluid eosinophilia occurs most often soon after peritoneal catheter insertion. It may be seen in the sterile peritonitis that can occasionally occur in those patients who have initiated treatment with icodextrin PD solution. The irritant effect of peritoneal air (e.g., introduced at time of laparotomy) and possibly of plasticizers leached into the peritoneum from PD solution containers and tubings is another suspected cause. In such cases, the eosinophilia most often resolves spontaneously within 2–6 weeks. Peritoneal fluid eosinophilia can also occur uncommonly during the treatment phase of peritonitis. There have been several case reports of its occurrence in association with fungal and parasitic infections of the peritoneum.
- g. **Culture of peritoneal fluid.** The incidence of positive peritoneal fluid cultures in patients suspected of having peritonitis depends on culture technique. Culture-negative peritonitis should not be $>20\%$ of episodes.
 1. **Storage.** Peritoneal fluid should be cultured promptly; however, infected fluid kept at room temperature or refrigerated for a period often grows pathogenic organisms on subsequent culture. If immediate delivery to the laboratory is not possible, the inoculated culture bottles should ideally be incubated at 37°C .
 2. **Sample volume.** The volume of peritoneal fluid sent for culture should be at least 50 mL as larger volumes increase the likelihood of a positive culture.
 3. **Sample preparation.** The aliquot is centrifuged (e.g., at 3,000 g for 15 minutes) to concentrate the organisms. The supernatant is decanted off, and the pellet resuspended in 3–5 mL of sterile saline and inoculated into standard blood culture media (aerobic and anaerobic). Rapid culture techniques (e.g., Septi-check, BACTEC) may be utilized.
 4. **Yield of positive cultures.** Seventy to ninety percent of dialysate samples taken from patients with clinical peritonitis yield positive cultures for a specific

organism within 24–48 hours. More time may be needed for more fastidious organisms.

5. **Improving culture yield.** This may be done by hypotonic lysis. The centrifuged sediment is resuspended in 100 mL of sterile water to induce lysis of its cellular elements. This may lead to release of bacteria from neutrophils and increase the chance of a positive culture, even in patients who have already received antibiotics.
6. **Incidence of false-positive results.** With very sensitive culture techniques, about 7% of cultures may be positive in patients without clinical peritonitis. The significance of this is unclear.
- h. **Gram stain.** Gram stain of the peritoneal fluid sediment is useful but positive in less than half of cases of culture-proven peritonitis. Gram stain is also useful for making the diagnosis of fungal peritonitis. Staining with fluorescent acridine orange dye has been reported to increase the visibility of bacterial organisms.
- i. **Necessity of performing blood cultures.** Routine blood cultures are not necessary unless a patient appears septic or an acute surgical abdominal condition is suspected.

E. Treatment

1. Initial management

- a. **Choice of antimicrobial therapy.** Empiric antibiotics must cover both gram-positive and gram-negative organisms. Vancomycin or a first-generation cephalosporin such as cefazolin or cephalothin is used in combination with an antibiotic such as ceftazidime or an aminoglycoside. In general, a center-specific selection of empiric therapy, dependent on the local history of sensitivities of organisms causing peritonitis, is recommended.
 1. **Gram-positive.** First-generation cephalosporins (e.g., cefazolin) are often preferred to vancomycin because of the emergence of vancomycin-resistant organisms. Intraperitoneal (IP) cefazolin can be conveniently administered in a single daily dose of 15 mg/kg, although a 25% increase in dose is recommended in patients with substantial residual renal function (Manley, 1999). Alternatives to vancomycin include nafcillin and clindamycin. Vancomycin can be used as first-line treatment or reserved for patients harboring β -lactam-resistant organisms, especially methicillin-resistant *S. aureus* (MRSA), or with penicillin/cephalosporin allergy. Ciprofloxacin alone is not recommended for gram-positive infections.
 2. **Gram-negative or indeterminate.** Gram stain is usually not diagnostic, and so gram-negative organisms need to be covered by a third-generation cephalosporin or aminoglycoside. In theory, aminoglycosides should be avoided if possible in patients with residual renal function because of their nephrotoxicity (Shemin, 1999), although short courses of aminoglycosides probably do not harm residual renal function (Lui, 2005). Aminoglycosides may be used in patients without residual renal function, although one still must be wary of otovestibular toxicity. Table 27.3 lists sample prescriptions based on the use of cefazolin in combination with ceftazidime.

b. **Delivery methods and schedules for antimicrobial drugs**

1. **IP versus oral (PO) or intravenous (IV) antimicrobial therapy.** IP administration of antibiotics is preferred to IV or PO dosing for treating peritonitis. IV antibiotics, however, should be used when there is clinical evidence of systemic sepsis.
2. **The loading dose.** A loading dose of antimicrobials is usually given IP when CAPD is the treatment modality (Table 27.4). If a patient appears toxic, an IV loading dose should be used. For aminoglycosides, the IV loading dose is usually gentamicin or tobramycin 1.5 mg/kg or amikacin 5 mg/kg. If a patient is in substantial pain and cannot tolerate the usual exchange volume, the IP loading dose can be administered in a smaller volume of dialysis solution (e.g., 1 L). For APD patients, the loading dose can be given IV, but it can also be instilled via a peritoneal dwell that is then left in place for at least 4–6 hours.

TABLE

27.3

Sample Prescriptions for Initial Treatment of Peritonitis with Unknown Organism Type

CAPD (continuous dosing method)

1. Drain abdomen and obtain cell count and culture from drainage bag. Change the transfer set.
2. Loading dose: Infuse 2-L dialysis solution containing 1,000 mg ceftazidime, 1,000 mg cefazolin, and 1,000 units heparin.
3. Allow to dwell 3–4 hr. In patients who appear septic, administer loading doses IV rather than IP.
4. Continue regular CAPD schedule, using normal exchange volume if tolerated. Add 125 mg/L ceftazidime, 125 mg/L cefazolin, and 500–1,000 units/L heparin to each dialysis solution bag.

CAPD (intermittent dosing method)

1. Drain abdomen and obtain cell count and culture from drainage bag. Change the transfer set.
2. Loading dose: same as the continuous dosing method.
3. Continue regular CAPD schedule, using normal exchange volume if tolerated. Administer ceftazidime 1,000 mg and cefazolin 1,000 mg into each nocturnal exchange. If fibrin or blood in dialysate, add heparin to every exchange.

APD: see text.

3. **Maintenance antimicrobial dose.** After the loading dose has been given, a CAPD or APD schedule is continued, with maintenance doses of antimicrobials added to each exchange (Table 27.4). Some centers switch APD patients to CAPD, but this is not routine. Maintenance antibiotics in CAPD patients can be administered as an intermittent dose once daily. For patients on an APD schedule, antibiotics can be administered conveniently in the daytime dwell. For patients on a day dry APD schedule, temporary conversion to a CAPD regimen may be considered because of ease of antibiotic administration, or,

alternatively, a low-volume daytime dwell (e.g., 1 L) could be temporarily added. Because of increased cyler clearance of antibiotics, doses need to be higher in patients who remain on APD during the treatment of peritonitis (Manley and Bailie, 2002). (Examples are given in Table 27.5.)

4. **Antimicrobial dosing guidelines.** Suggested loading and maintenance doses for a number of antimicrobial drugs are listed in Table 27.4. For maintenance doses added to the dialysis solution, continuous and intermittent dosing of antibiotics are equally efficacious. For continuous dosing, the same dose of antibiotic is added to each dialysis solution bag. Alternatively, a larger dose is added to one bag only, every 12 or 24 hours (or, in the case of vancomycin, every 4–5 days). A randomized trial in children showed that intermittent vancomycin was as effective as continuous vancomycin (Schaefer, 1999). Single daily dosing of aminoglycosides has several advantages, including ease of administration, increased efficacy, and potentially less toxicity. Increased bacterial killing rates associated with prolonged postantibiotic effect are obtained using once-daily dosing. However, trough concentrations of antibiotic (i.e., 24 hours after a dose) will be low, and the exact duration of the postantibiotic effect is unknown, which has led to some concern about the advisability of this type of regimen, especially in patients with residual renal function (Low, 1996).

There has been interest in once-daily cephalosporin dosing. Cefazolin at 1–2 g IP daily has been tried (Lai, 1997; Troidle, 1997). However, IP cephalosporin levels may fall below the minimum inhibitory concentration (MIC) of most organisms. As there is no postantibiotic effect with cephalosporins, in contrast to aminoglycosides, there is some concern that once-daily dosing may lead to more treatment failures than intermittent dosing (Fielding, 2002). In general, continuous dosing of cephalosporins is preferred, but intermittent dosing is also widely used.

TABLE
27.4 Loading and Maintenance Doses of Antimicrobials for Peritonitis (CAPD)^a

	Intermittent (per exchange, once daily)	Continuous (mg/L, all exchanges)
Aminoglycosides		
Amikacin	2 mg/kg	LD 25, MD 12
Gentamicin, netilmicin, or tobramycin	0.6 mg/kg	LD 8, MD 4
Cephalosporins		
Cefazolin, cephalothin, or cephradine	15 mg/kg	LD 500, MD 125
Cefepime	1,000 mg	LD 500, MD 125
Ceftazidime	1,000–1,500 mg	LD 500, MD 125
Penicillins		
Ampicillin, oxacillin, or nafcillin	ND	MD 125

Amoxicillin	ND	LD 250–500, MD 50
Penicillin G	ND	LD 50,000 units, MD 25,000 units
Quinolones		
Ciprofloxacin	ND	LD 50, MD 25
Others		
Vancomycin	15–30 mg/kg every 5–7 d	LD 1,000, MD 25
Daptomycin	ND	LD 100, MD 20
Linezolid	Oral 200–300 mg q. d.	
Antifungals		
Fluconazole	200 mg IP every 24–48 hr	
Amphotericin	NA	1.5
Combinations		
Ampicillin–Sulbactam	2 g every 12 hr	LD 1,000, MD 100
Trimethoprim–Sulfamethoxazole	160 mg/800 mg oral twice daily	
Imipenem–Cilastin	1 g b. i. d.	LD 250, MD 50

b. i. d., two times per day; LD, loading dose in mg; MD, maintenance dose in mg; NA, not applicable; ND, no data.

^a Dosing of drugs with renal clearance in patients with residual renal function (defined as >100 mL per day urine output): dose should be empirically increased by 25%.

Adapted from Li et al. Peritoneal dialysis related infections recommendations: 2010 update. *Perit Dial Int.* 2010;30:393–423.

TABLE
27.5 Intermittent Dosing of Antibiotics in Automated Peritoneal Dialysis (APD)

Drug	IP dose
Vancomycin	Loading dose 30 mg/kg IP in long dwell, repeat dosing 15 mg/kg IP in long dwell every 3–5 d (aim to keep serum trough levels above 15 mcg/mL)
Cefazolin	20 mg/kg IP every day, in long day dwell
Tobramycin	Loading dose 1.5 mg/kg IP in long dwell, then 0.5 mg/kg IP each day in long dwell
Fluconazole	200 mg IP in one exchange per d every 24–48 hr
Cefepime	1 g IP in one exchange per d

Adapted from Li et al. Peritoneal dialysis related infections recommendations: 2010 update (2010).

- Stability of antibiotics in dialysate.** Vancomycin, aminoglycosides, and cephalosporins can be mixed in the same dialysis solution bag; however, aminoglycosides are incompatible with penicillins. Vancomycin (25 mg/L) is stable for 28 days in dialysis solution stored at room temperature, although high ambient temperatures will reduce the duration of stability. Gentamicin (8

mg/L) is stable for 14 days, but the duration of stability is reduced by the admixture of heparin. Cefazolin (500 mg/L) is stable for at least 8 days at room temperature or for 14 days if refrigerated; addition of heparin does not impair stability. Ceftazidime is less stable; concentrations of 125 mg/L are stable for 4 days at room temperature or 7 days if refrigerated, and concentrations of 200 mg/L are stable for 10 days if refrigerated.

- c. **Heparin.** Peritonitis is often associated with formation of fibrinous clots in the peritoneal fluid, and the risk of catheter obstruction is high. Most centers add heparin (500–1,000 units/L) to the dialysis solution until peritonitis resolves and fibrinous clots are no longer visible in the effluent.
- d. **Nystatin.** Since the majority of fungal peritonitis episodes are preceded by courses of antibiotics, fungal prophylaxis during antibiotic therapy may prevent some cases of *Candida* peritonitis in programs that have high rates of fungal peritonitis. A number of studies have examined the use of oral nystatin prophylaxis, given during antibiotic therapy, to prevent fungal peritonitis, and the results are mixed. We believe nystatin prophylaxis should be considered in programs with high baseline rates of fungal peritonitis.
- e. **Alterations in schedule for CAPD and APD.** CAPD patients can generally continue their normal schedule of exchanges, unless ultrafiltration becomes inadequate. Some centers prefer to treat moderate-to-severe peritonitis in both CAPD and APD patients for the initial 24–48 hours with a series of 3–4 hour exchanges containing antibiotics administered via a cycler. In APD patients with mild-to-moderate peritonitis, the usual APD schedule can be continued unchanged with antibiotics administered either continuously (added to all exchanges) or intermittently (added only to the daytime dwell). Some convert the patient to CAPD but this may be a problem for patients, especially if they are being treated at home. Doses of antimicrobials for those who remain on APD are provided in Table 27.5. The decision to hospitalize a patient depends on a variety of factors, including patient reliability, severity of peritonitis, and the treatment schedule chosen. In most centers, the majority of cases are now managed as outpatients.
- f. **Consideration of secondary peritonitis.** In a small but significant proportion of patients with peritonitis, a serious, underlying intra-abdominal disease process (e.g., perforated peptic ulcer, pancreatitis, appendicitis, or diverticulitis) may be present. The presence of peritoneal fluid in the abdomen may mask the local tenderness commonly associated with some of these conditions. If there is any suspicion of an underlying intra-abdominal disease process, a chest radiograph should be obtained. The presence of free IP air on upright chest radiograph is an unusual finding in CAPD patients, provided recent laparotomy or transfer set change has not been performed, and may suggest the presence of a perforated viscus. However, free IP air may occur more commonly in patients being treated with cyclers.
- g. **Amylase and lipase.** In a dialysis patient suspected of having pancreatitis, the finding of a serum total amylase value in excess of three times the upper limit of normal

suggests that pancreatitis is present. Very severe pancreatitis can be present in dialysis patients with only slight, and therefore nondiagnostic, elevations in the serum total amylase level. The peritoneal fluid amylase concentration, easily obtainable in patients receiving PD, is not a sensitive indicator of pancreatitis because the peritoneal fluid amylase levels can be only slightly elevated in the presence of severe pancreatitis. Nevertheless, an effluent amylase level >100 units/dL is suggestive of pancreatitis or some other intra-abdominal catastrophe.

Serum lipase activity is elevated (as high as twice the upper limit of normal) in about 50% of dialysis patients. In PD patients using icodextrin-based PD solutions, measurement of lipase is superior to amylase for diagnosis of acute pancreatitis.

- h. **Consequence of changes in peritoneal permeability.** During peritonitis, the permeability of the peritoneum to water, glucose, and proteins is increased. Rapid glucose absorption from the dialysis solution reduces the amount of ultrafiltration and can result in fluid overload. Higher dialysis solution glucose levels and shorter dwell times may be needed to maintain adequate ultrafiltration. Because glucose absorption is more rapid during peritonitis, hyperglycemia may result and can be severe in diabetic patients unless glucose values are monitored and insulin doses titrated. Protein losses during peritonitis are temporarily increased.
 - i. **Constipation.** Constipation is a common complaint during peritonitis episodes, and constipation may itself be a risk factor for developing peritonitis, in addition to its impact on poor drainage of instilled dialysate. If constipation is present, calcium-containing phosphate binders, which can cause or worsen constipation, should be temporarily discontinued.
2. **Initial management of peritoneal contamination without peritonitis.** After bacterial contamination of the peritoneal cavity, the incubation period for most organisms is about 12–48 hours. If a break in sterile technique has occurred, it is advisable to institute antimicrobial therapy promptly in order to prevent peritonitis. The transfer set should be changed, and the peritoneal cavity flushed with dialysis solution containing an antistaphylococcal antibiotic. A short (1- to 2-day) course of oral antimicrobial therapy (e.g., ciprofloxacin) may also be given. However, there is no documentation that these procedures are effective in preventing peritonitis.
 3. **Change in management of peritonitis based on patient course and initial culture results.** With effective treatment, the patient should begin to improve clinically within 12–48 hours, and the total cell count and percentage of neutrophils in the peritoneal fluid should begin to decrease. Often visual inspection of the effluent will suffice, but if there is no improvement within 48 hours, repeat cell count and culture are necessary. Isolation of causative bacteria and determination of their antimicrobial sensitivity can generally be obtained within 2–3 days. Longer growth periods may be needed for certain fastidious organisms (e.g., gentamicin- and methicillin-resistant *S. aureus*). A single organism is isolated in 70%–90% of cases (Table 27.1).
 - a. **Gram-positive organism cultured.** If *S. aureus*, *S. epidermidis*, or a *Streptococcus* sp. is identified, then continued therapy with a single antimicrobial

agent is recommended. If an aminoglycoside was given initially, it can now be stopped. Many *S. epidermidis*-like organisms reported to be resistant to first-generation cephalosporins are sensitive to the levels achieved in the peritoneal cavity. Thus, if the patient is clinically responding to treatment, there is usually no need to change the antibiotic regimen. If an *Enterococcus* sp. is cultured, ampicillin or vancomycin plus an aminoglycoside is generally employed, unless sensitivity testing indicates vancomycin resistance, in which case linezolid or quinupristin/dalfopristin is needed.

1. **Duration of therapy.** For coagulase-negative *Staphylococcus* and *Enterococcus* peritonitis, if patient improvement is prompt, antimicrobial therapy should be continued for a total of 14 days. *S. aureus* peritonitis requires antimicrobials for 3 weeks, and rifampin could be considered an adjunct for the prevention of relapse or repeat *S. aureus* peritonitis. Rifampin induces cytochrome P450 (CYP3A4), which should be kept in mind when the patient is taking other medications metabolized by this pathway. *S. aureus* peritonitis with concurrent exit-site or tunnel infection is unlikely to respond to antibiotic therapy without catheter removal.
 2. **Nasal carriage and *S. aureus* infection.** Patients who develop *S. aureus* peritonitis are usually nasal carriers of this organism. Eradication of nasal carriage may help prevent further peritoneal infections by this bacterium. This can be accomplished with intranasal mupirocin (bid for 5 days every 4 weeks) or oral rifampin (300 mg bid for 5 days every 3 months). Resistance to mupirocin and rifampin is increasingly common. Eradication of the carrier state should be documented by repeating appropriate cultures after antibacterial treatment.
- b. **Gram-negative organism cultured.** Recovery of a gram-negative organism, even in a patient who is improving clinically, has several important implications: (a) gram-negative infections (especially *Pseudomonas* sp.) are hard to eradicate, and the risk of relapsing peritonitis is high, (b) gram-negative peritonitis may be a sign of unsuspected intra-abdominal pathology, and (c) prolonged treatment with aminoglycosides carries the risk of otovestibular toxicity.

If a single, non-*Pseudomonas* sp. is recovered, the peritonitis can usually be treated by continuation of the initial IP third-generation cephalosporin or aminoglycoside alone, or by another single appropriate antibiotic, although some centers prefer to use two agents. If a *Pseudomonas* sp. is recovered, two antibiotics are mandatory. Usually, the IP aminoglycoside should be continued with the addition of a third-generation cephalosporin administered IP or a semisynthetic penicillin with anti-*Pseudomonas* activity (e.g., piperacillin) administered IV. Semisynthetic penicillins can inactivate aminoglycosides in vitro, and IP coadministration should be avoided. Other alternatives are ciprofloxacin (or another quinolone), aztreonam, imipenem, and trimethoprim-sulfamethoxazole. *Pseudomonas* peritonitis requires catheter removal in up to two-thirds of cases (Bunke, 1995). Fluoroquinolones (such as ciprofloxacin and ofloxacin) have the advantage that effective dialysate levels can usually be achieved after PO dosing;

their concurrent administration with phosphate-binding antacids should be avoided to ensure adequate absorption from the gastrointestinal tract.

1. **Duration of therapy.** In uncomplicated cases, duration of therapy for gram-negative peritonitis is at least 2 and preferably 3 weeks. If the peritoneal catheter is removed, appropriate antibiotics should be continued (either PO or IV) for another 2 weeks, especially with *Pseudomonas*.
 2. **IP aminoglycoside toxicity.** To treat gram-negative peritonitis, a prolonged course (2 weeks) of aminoglycosides may be required. In the usual dosing strategy (after the loading dose), 4–6 mg/L of gentamicin, tobramycin, or netilmicin is added to the PD solution. This results in constant serum drug levels, which may cause otovestibular toxicity. Adding a higher dose to a single bag only every 24 hours (e.g., 20 mg/L of gentamicin or tobramycin) avoids constant serum levels above 2 mg/L and may reduce the toxicity of IP aminoglycosides.
 3. **Alternative agents.** Many gram-negative organisms are sensitive to aztreonam, newer cephalosporins, quinolones, imipenem, or the semisynthetic penicillins. Use of these alternative agents should be considered both initially and when prolonged therapy of gram-negative peritonitis is required.
 4. **Infection with *Stenotrophomonas* (formerly *Xanthomonas*) sp.** The major risk factor for infection with *Stenotrophomonas maltophilia* is the previous use of broad-spectrum antibiotics. These are usually very resistant organisms. Medical therapy requires two antibiotics, usually including cotrimoxazole, and must be extended to a minimum of 3–4 weeks, and catheter removal is usually required (Szeto, 1997).
- c. **Polymicrobial peritonitis.** In general, peritonitis due to multiple gram-positive organisms will respond to antibiotic therapy. About 60% of these infections resolve without catheter removal (Szeto, 2002b).

In contrast, if multiple enteric organisms are grown, particularly in association with anaerobic bacteria, the presence of an intra-abdominal abscess or a perforated abdominal viscus must be considered. Perforated diverticulum, tubo-ovarian abscess, cholecystitis, appendicitis, perforated ulcer, and pancreatitis must all be included in the differential diagnosis. The risk of mortality is increased (Kern, 2002). Initial management can be accomplished by triple-antibiotic therapy aimed at gram-positive, gram-negative, and anaerobic organisms. Use of an IP aminoglycoside, IP vancomycin, and PO or IV metronidazole is usual. A surgical evaluation should be obtained, and management must be individualized.

- d. **Culture-negative peritonitis.** If the culture results are negative at 24 hours, then the most likely explanation is that a bacterial infection was present but that the responsible organisms failed to grow in the culture sample. Sometimes, growth appears only after 5–7 days, and cultures should be incubated for this length of time. Management depends on whether the patient is improving clinically. Although the current ISPD recommendation is to continue both of the initial antibiotics for a full 14 days (Li, 2010), many authorities recommend discontinuing the gram-negative coverage (i.e., ceftazidime or aminoglycoside) after 3 days if the patient is

improving. Patients with culture-negative peritonitis who do not improve should be recultured using special culture techniques to look for unusual organisms such as yeast, mycobacteria, and fungi. If a dialysis program has a rate of culture-negative peritonitis >20%, the culture methods should be reviewed.

Infection with *Mycobacterium tuberculosis* or with nontuberculous mycobacteria sometimes presents as culture-negative peritonitis. When mycobacterial peritonitis is suspected, special attention must be paid to culture techniques. Diagnostic sensitivity can be improved by culturing the sediment after centrifugation of a large volume of effluent (50–100 mL) using a solid medium (such as Lowenstein–Jensen agar) and a fluid medium (Septi-check, BACTEC, etc.). Catheter removal is often required but is not mandatory provided prompt therapy is given. This consists of a multiple-drug regimen (usually isoniazid, rifampin, ofloxacin, and pyrazinamide). Streptomycin and ethambutol are generally not recommended in dialysis patients.

- e. **Fungal peritonitis.** Fungal peritonitis is a serious complication and should be strongly suspected after recent antibiotic treatment for bacterial peritonitis. Other predisposing factors to fungal peritonitis include diabetes mellitus, immunosuppression (e.g., immunosuppressive therapy, HIV infection), and malnutrition, especially a low serum albumin level. *Candida* is the most prevalent species cultured, but many types of fungi can be responsible. The ISPD recommendation is prompt removal of the catheter as soon as fungi are identified by gram stain or culture (Li, 2010), together with treatment for at least 10 days with antifungal agents. The patient is then maintained on hemodialysis. In some patients, a new catheter can be inserted 4–6 weeks later, provided that at least 1 week has elapsed since all clinical evidence of peritonitis has subsided.

In an attempt to limit adhesion formation, in addition to catheter removal, prolonged oral administration of antifungal drugs, such as flucytosine, miconazole, fluconazole, ketoconazole, itraconazole, or voriconazole, has been employed. Voriconazole or posaconazole is an alternative to amphotericin B when filamentous fungi have been cultured, but neither of them can be used alone for *Candida* peritonitis (even with catheter removal). The recommended dosages of these agents are the same as for patients with normal renal function, with the exception of flucytosine, for which the dosage must be reduced (see Chapter 35). The unavailability of oral flucytosine in many countries and the high price of many new antifungal agents may affect local practice.

4. **Refractory peritonitis and indications for catheter removal.** Refractory peritonitis is defined as failure of peritonitis to clear after 5 days of appropriate antibiotics. Catheter removal is indicated in order to reduce patient morbidity and preserve the peritoneal membrane. Ultrasound, computed tomography, or gallium scan is indicated if an intra-abdominal abscess is suspected, since in such cases surgical exploration and drainage may be needed at the time of or after catheter removal. In general, it is preferable to remove the PD catheter in patients who do not respond to antimicrobials rather than subject the patient to a long period of exposure to antibiotics, with increased risk of superinfection

and morbidity, and of damage to the peritoneal membrane. After catheter removal, the safe time interval before a new catheter can be inserted is controversial and probably depends on the severity of the peritonitis and whether fungal peritonitis or tunnel infection was present. A conservative approach is to wait 4–6 weeks. Resumption of PD is possible in approximately one-half of patients, but may necessitate a change in dialysis prescription to achieve adequate dialysis and ultrafiltration (Szeto, 2002a).

5. **Relapsing, recurrent, and repeat peritonitis.** Relapsing peritonitis is defined as peritonitis with the same organism within 4 weeks of stopping antimicrobial therapy; *S. epidermidis* or a gram-negative organism is usually involved, but relapsing culture-negative peritonitis is also common. In the case of relapsing gram-negative peritonitis, catheter removal, with or without surgical exploration, should be strongly considered, especially in cases of *Pseudomonas* infection. If it is decided to treat the patient medically, either the aminoglycoside dose should be administered intermittently or an alternative agent should be employed. With less serious infections, it may be possible to insert a new catheter, simultaneous with the removal of the old one, obviating the need for hemodialysis. The new catheter should be inserted well away from the old exit site. This approach has been particularly useful in the management of relapsing peritonitis due to coagulase-negative staphylococci.

Recent studies suggest that relapsing and recurrent peritonitis episodes are caused by a different spectrum of bacteria, and probably represent two distinct clinical entities (Szeto, 2009). Notably, recurrent peritonitis episodes had a worse prognosis than relapsing ones. Although repeat peritonitis episodes generally have a satisfactory response to antibiotic, they have a substantial risk of developing further relapsing or repeat peritonitis (Szeto, 2011b) with treatments of relapsing, recurrent, or repeat peritonitis.

- a. **Fibrinolytic enzymes.** Streptokinase and urokinase have been used by some investigators in the treatment of refractory or relapsing peritonitis. These agents are used in an attempt to release bacteria entrapped in fibrin within the peritoneum or along the catheter, thus making it possible to eradicate the infection. Controlled studies have not proved this approach to be effective compared with catheter removal and replacement (Williams, 1989).
6. **Peritonitis with catheter obstruction.** Catheter obstruction often accompanies peritonitis. Management is discussed in Chapter 23.
7. **Prophylactic antibiotic use.** Prophylactic antibiotic use does not prevent peritonitis; this is probably true even for patients with exit-site infections. However, short-term prophylactic systemic antibiotics may be beneficial in the following settings: (a) before catheter placement (vancomycin or cefazolin); (b) to prevent bacteremia during invasive procedures, such as dental procedures (amoxicillin 2 g) or colonoscopy, colonoscopic polypectomy, hysteroscopy, or cholecystectomy (ampicillin plus an aminoglycoside); and (c) after an accidental contamination.
8. **Prevention.** The use of prophylactic antibiotic has been discussed above. Spiking of dialysis bags is a high-risk procedure for contamination of the system; the “flush before fill” reduces the risk of contamination. Double-cuffed catheters may provide an added

barrier to peritoneal movement of *S. aureus* into the peritoneum, and they are clearly superior to single-cuffed catheters in decreasing the risk of peritonitis. No particular catheter has been definitively shown to be better than the standard silicon double-cuff catheter for the prevention of peritonitis.

A number of perioperative measures may help to reduce the incidence of peritonitis (Crabtree, 2005). Skin exit site should be directed downward or laterally. Subcutaneous tunnel incision should not exceed the diameter of the dialysis catheter. The subcutaneous cuff should be positioned 2 to 3 cm from the exit site. Exit site should be the smallest hole possible that provides catheter exit. There should be no sutures anchoring the catheter at the exit site.

Hypokalemia is associated with an increased risk of enteric peritonitis, and therefore if present, should be treated. There is an association between both severe constipation and enteritis and peritonitis owing to enteric organisms. It is logical to treat any bacterial enteritis if present. A recent observational study suggests that lactulose treatment may reduce the risk of peritonitis (Afsar, 2010).

Training methods have a substantial influence on the risk of PD infections, and training should follow standard guidelines (Bernardini, 2006); each PD program should consult the standard ISPD guidelines to prepare the trainer and develop a specific curriculum. Each program must also decide when and how often to routinely retrain patients; there is no published study in this area. Retraining should be considered following peritonitis or catheter infection, as well as following change in dexterity, vision, or mental acuity. After each peritonitis episode, it is prudent to perform a root cause analysis to determine etiology so that interventions can be planned to prevent future episodes.

II. EXIT-SITE AND TUNNEL INFECTION. Approximately one-fifth of peritonitis episodes are temporally associated with exit-site and tunnel infections (Piraino, 2005). Purulent drainage from the exit site generally indicates the presence of infection, while erythema alone may or may not represent infection.

A. Incidence. The incidence of exit-site infections is approximately 1 episode every 24–48 patient-months. Patients with previous infections tend to have a higher frequency of occurrence.

B. Etiology and pathogenesis. Exit-site infections are predominantly due to *S. aureus* and *P. aeruginosa*. *S. epidermidis* is the causative organism in <20% of patients. Approximately 45% of patients are nasal carriers of *S. aureus*, and nasal carriage is associated with exit-site infection and peritonitis (Luzar, 1990a, 1990b). Eradication of the carrier state is helpful in effective management.

C. Therapy. Treatment is dependent on whether there is erythema alone, or erythema along with purulent drainage. For erythema alone, topical treatment with hypertonic saline, hydrogen peroxide, or mupirocin 2% ointment is usually sufficient. Mupirocin ointment should not be used with polyurethane catheters (e.g., many catheters made by Vas-Cath or the Cruz catheter from Corpak) because the polyethylene glycol in mupirocin ointment will degrade the polyurethane and destroy the catheter. Ciprofloxacin otologic solution can be used with

polyurethane catheters, but efficacy in treating exit-site infection is unknown (Montenegro, 2000).

Treatment is more problematic when there is exit-site infection with purulent drainage; such infection may extend into the subcutaneous tunnel and be evident only on ultrasound examination of the catheter tract (Vychytil, 1999). Therapy should be based on the results of gram stain and culture. The gram stain of exit-site drainage and microbiologic culture findings can guide initial therapy. If gram-positive organisms are found, a cephalosporin or an antistaphylococcal penicillin PO is first-line treatment. If no improvement occurs after 1 week despite appropriate treatment based on culture and sensitivity, rifampin 600 mg per day PO may be added. If the infection has not resolved in 2 weeks, a surgical approach (deroofting, outer-cuff shaving, or catheter removal) may be required. If tunnel infection is present, early cuff excision in combination with antibiotic administration results in a substantial rate of catheter salvage (Suh, 1997), although catheter removal is sometimes required, especially when there is coexisting peritonitis.

If gram-negative organisms are present, treatment should be based on sensitivity results. Oral quinolones are useful, though care must be taken to avoid ingestion of multivalent cations (calcium, iron, zinc, antacids) within 2 hours of drug ingestion. With more serious pseudomonal infections, IP ceftazidime or aminoglycoside may be necessary. Regardless, antibiotic therapy must be continued until the exit site appears entirely normal. Two weeks is the minimum length of treatment time, and treatment for 3 weeks is probably necessary for exit-site infections caused by *P. aeruginosa*. Catheter removal should be considered at an early time point for exit-site infections caused by *P. aeruginosa* or if there is tunnel infection; replacement with a new catheter at a different site as a single procedure is often feasible. Table 27.6 lists appropriate oral antimicrobial doses for the treatment of exit-site infections.

- D. **Prevention.** Antibiotic protocols against *S. aureus* nasal carriage are effective in reducing the risk of *S. aureus* catheter infections. Protocols used include rifampin (600 mg PO for 5 days), mupirocin (2% ointment twice daily for 5 days every 4 weeks), and trimethoprim-sulfamethoxazole (one single-strength tablet three times weekly). In a randomized controlled trial, rifampin 600 mg PO for 5 days given every 3 months was effective in decreasing catheter infections (Zimmerman, 1991). In a multicenter randomized trial (Mupirocin Study Group, 1996), use of nasal mupirocin in the regimen stated above in *S. aureus* nasal carriers resulted in a significant decline in exit-site infections from this organism; however, the overall incidence of exit-site infections was not decreased because of an increase in gram-negative infections, and rates of tunnel infection and peritonitis were not affected.

TABLE

27.6

Oral Antimicrobial Doses for Exit-Site and Tunnel Infections

Amoxicillin	250–500 mg b.i.d.
Cephalexin	500 mg b.i.d.

Ciprofloxacin	250–500 mg b.i.d.
Clarithromycin	250–500 mg b.i.d.
Dicloxacillin	250–500 mg b.i.d.
Fluconazole	200 mg once daily
Flucloxacillin	500 mg b.i.d.
Flucytosine	2-g load, then 1 g PO, q.day
Isoniazid	300 mg once daily
Linezolid	600 mg b.i.d.
Metronidazole	400 mg b.i.d. for <50 kg 400–500 t.i.d. for >50 kg
Ofloxacin	400 mg first day, then 200 mg once daily
Pyrazinamide	35 mg/kg per day (given as b.i.d. or once daily)
Rifampin	450 mg once daily for <50 kg 600 mg once daily for >50 kg
Trimethoprim/sulfamethoxazole	80/400 mg once daily

b.i.d., two times per day; PO, orally; t.i.d., three times per day.

Reproduced from Piraino B, et al. Peritoneal dialysis-related infections recommendations: 2005 update. *Perit Dial Int.* 2005;25:107–131.

Prevention of catheter infections (and thus peritonitis) is the primary goal of exit-site care. There are sufficient data to support the use of exit-site antibiotic cream (either mupirocin or gentamicin) in all patients. In two clinical trials, mupirocin ointment applied daily to the exit site decreased the rate of both exit-site infections and peritonitis in comparison with a historical control group (Bernardini, 1996; Thodis, 1998). In another study (Bernardini, 2005), gentamicin cream was as effective as mupirocin in preventing *S. aureus* infections and reduced *P. aeruginosa* and other gram-negative catheter infections. Peritonitis, particularly that caused by gram-negative organisms, was reduced by 35%. Because of its efficacy against both gram-positive and gram-negative infections, daily gentamicin cream at the exit site has been advocated as the prophylaxis of choice for PD patients. However, the risk of aminoglycoside resistance after prolonged usage has not been assessed.

Whether the incidence of exit-site infections is lower with double-cuff catheters is somewhat controversial (Nessim, 2010; Segal, 2013). The method of catheter placement may be important. Leaving the catheter embedded subcutaneously for several weeks after placement (see Chapter 23) and then exteriorizing it prior to use may reduce the rate of exit-site infection. Use of chlorhexidine versus povidone–iodine solution is associated with a

significant decrease in exit-site infections in children (Jones, 1995). Polyhexanide solution also appears to be better than povidone–iodine (Núñez-Moral, 2014).

References and Suggested Readings

- Afsar B, et al. Regular lactulose use is associated with lower peritonitis rates: an observational study. *Perit Dial Int*. 2010;30:243–246.
- Ballinger AE, et al. Treatment for peritoneal dialysis-associated peritonitis. *Cochrane Database Syst Rev*. 2014;26:CD005284.
- Bernardini J, Price V, Figueiredo A; International Society for Peritoneal Dialysis (ISPD) Nursing Liaison Committee. Peritoneal dialysis patient training, 2006. *Perit Dial Int*. 2006;26:625–632.
- Bernardini J, et al. A randomized trial of *Staphylococcus aureus* prophylaxis in peritoneal dialysis patients: mupirocin calcium ointment 2% applied to the exit site versus cyclic oral rifampin. *Am J Kidney Dis*. 1996;27:695–700.
- Bernardini J, et al. Randomized, double-blind trial of antibiotic exit site cream for prevention of exit site infection in peritoneal dialysis patients. *J Am Soc Nephrol*. 2005;16:539–545.
- Bunke M, et al. *Pseudomonas* peritonitis in peritoneal dialysis patients: the Network 9 Peritonitis Study. *Am J Kidney Dis*. 1995;25:769–774.
- Cho Y, Johnson DW. Peritoneal dialysis-related peritonitis: towards improving evidence, practices, and outcomes. *Am J Kidney Dis*. 2014;64:278–289.
- Cho Y, et al. Biocompatible dialysis fluids for peritoneal dialysis. *Cochrane Database Syst Rev*. 2014;27:CD007554.
- Choi P, et al. Peritoneal dialysis catheter removal for acute peritonitis: a retrospective analysis of factors associated with catheter removal and prolonged postoperative hospitalization. *Am J Kidney Dis*. 2004;43:103–111.
- Crabtree JH, et al. A laparoscopic method for optimal peritoneal dialysis access. *Am Surg*. 2005;71:135–143.
- Daugirdas JT, et al. Induction of peritoneal fluid eosinophilia and/or monocytosis by intraperitoneal air injection. *Am J Nephrol*. 1987;7:116–120.
- Elamin S, et al. Low sensitivity of the exit site scoring system in detecting exit site infections in peritoneal dialysis patients. *Clin Nephrol*. 2014;81:100–104.
- Fielding RE, et al. Treatment and outcome of peritonitis in automated peritoneal dialysis, using a once-daily cefazolin-based regimen. *Perit Dial Int*. 2002;22:345–349.
- Gadallah M, et al. Role of preoperative antibiotic prophylaxis in preventing postoperative peritonitis in newly placed peritoneal dialysis catheters. *Am J Kidney Dis*. 2000;36:1014–1019.
- Humayun HM, et al. Peritoneal fluid eosinophilia in patients undergoing maintenance peritoneal dialysis. *Arch Intern Med*. 1981;141:1172–1173.
- Jones LL, et al. The impact of exit-site care and catheter design on the incidence of catheter-related infections. *Adv Perit Dial*. 1995;11:302–305.
- Kern EO, et al. Abdominal catastrophe revisited: the risk and outcome of enteric peritoneal contamination. *Perit Dial Int*. 2002;22:323–324.
- Kerschbaum J, et al. Treatment with oral active vitamin D is associated with decreased risk of peritonitis and improved survival in patients on peritoneal dialysis. *PLoS One*. 2013;8:e67836.
- Lai MN, et al. Intraperitoneal once-daily dosing of cefazolin and gentamicin for treating CAPD

peritonitis. *Perit Dial Int.* 1997;17:87–89.

Li PK, et al. Use of intraperitoneal cefepime as monotherapy in treatment of CAPD peritonitis. *Perit Dial Int.* 2000;20:232–234.

Li PK, et al. Comparison of clinical outcome and ease of handling in two double-bag systems in continuous ambulatory peritoneal dialysis—a prospective randomized controlled multi-center study. *Am J Kidney Dis.* 2002;40:373–380.

Li PK, et al. Peritoneal dialysis-related infections recommendations: 2010 update. *Perit Dial Int.* 2010;30:393–423.

Li PK, et al. Infectious complications in dialysis—epidemiology and outcomes. *Nat Rev Nephrol.* 2012;8:77–88.

Low CL, et al. Pharmacokinetics on once-daily IP gentamicin in CAPD patients. *Perit Dial Int.* 1996;16:379–384.

Lui SL, et al. Cefazolin plus netilmicin versus cefazolin plus ceftazidime for treating CAPD peritonitis: effect on residual renal function. *Kidney Int.* 2005;68:2375–2380.

Luzar MA, et al. Exit-site care and exit-site infection in continuous ambulatory peritoneal dialysis (CAPD): results of a randomized multicenter trial. *Perit Dial Int.* 1990a;10:25–29.

Luzar MA, et al. *Staphylococcus aureus* nasal carriage and infection in patients on continuous ambulatory peritoneal dialysis. *N Engl J Med.* 1990b;322:505–509.

Manley HJ, et al. Pharmacokinetics of intermittent intraperitoneal cefazolin in continuous ambulatory peritoneal dialysis patients. *Perit Dial Int.* 1999;19:67–70.

Manley HJ, Bailie GR. Treatment of peritonitis in APD: pharmacokinetic principles. *Semin Dial.* 2002;15:418–21.

Montenegro J, et al. Exit-site care with ciprofloxacin otologic solution prevents polyurethane catheter infection in peritoneal dialysis patients. *Perit Dial Int.* 2000;20:209–214.

Monteon F, et al. Prevention of peritonitis with disconnect systems in CAPD: a randomized controlled trial. The Mexican Nephrology Collaborative Study Group. *Kidney Int.* 1998;54:2123–2138.

Mupirocin Study Group. Nasal mupirocin prevents *Staphylococcus aureus* exit-site infection during peritoneal dialysis. *J Am Soc Nephrol.* 1996;7:2403–2408.

Nessim SJ, Bargman JM, Jassal SV. Relationship between double-cuff versus single-cuff peritoneal dialysis catheters and risk of peritonitis. *Nephrol Dial Transplant.* 2010;25:2310–2314.

Núñez-Moral M, et al. Exit-site infection of peritoneal catheter is reduced by the use of polyhexanide: results of a prospective randomized trial. *Perit Dial Int.* 2014;34: 271–277.

Piraino B, et al. A five-year study of the microbiologic results of exit site infections and peritonitis in continuous ambulatory peritoneal dialysis. *Am J Kidney Dis.* 1987;4:281–286.

Piraino B, et al. Increased risk of *Staphylococcus epidermidis* peritonitis in patients on dialysate containing 1.25 mmol/L calcium. *Am J Kidney Dis.* 1992;19:371–374.

Piraino B, et al. Peritoneal dialysis-related infections recommendations: 2005 update. *Perit Dial Int.* 2005;25:107–131.

Piraino B, et al. ISPD position statement on reducing the risks of peritoneal dialysis-related infections. *Perit Dial Int.* 2011;31:614–630.

Ram R, et al. Cloudy peritoneal fluid attributable to non-dihydropyridine calcium channel blocker. *Perit Dial Int.* 2012;32:110–111.

- Schaefer F, et al. Intermittent versus continuous intraperitoneal glycopeptide/ceftazidime treatment in children with peritoneal dialysis-associated peritonitis. The Mid-European Pediatric Peritoneal Dialysis Study Group (MEPPS). *J Am Soc Nephrol*. 1999;10:136–45.
- Segal JH, Messana JM. Prevention of peritonitis in peritoneal dialysis. *Semin Dial*. 2013;26:494–502.
- Shemin D, et al. Effect of aminoglycoside use on residual renal function in peritoneal dialysis patients. *Am J Kidney Dis*. 1999;34:14–20.
- Suh H, et al. Persistent exit-site/tunnel infection and subcutaneous cuff removal in PD patients. *Adv Perit Dial*. 1997;13:233–236.
- Szeto CC, et al. *Xanthomonas maltophilia* peritonitis in uremic patients receiving continuous ambulatory peritoneal dialysis. *Am J Kidney Dis*. 1997;29:91–96.
- Szeto CC, et al. Feasibility of resuming peritoneal dialysis after severe peritonitis and Tenckhoff catheter removal. *J Am Soc Nephrol*. 2002a;13:1040–1045.
- Szeto CC, et al. Conservative management of polymicrobial peritonitis complicating peritoneal dialysis—a series of 140 consecutive cases. *Am J Med*. 2002b;113: 728–733.
- Szeto CC, et al. Recurrent and relapsing peritonitis: causative organisms and response to treatment. *Am J Kidney Dis*. 2009;54:702–710.
- Szeto CC, et al. Persistent symptomatic intra-abdominal collection after catheter removal for PD-related peritonitis. *Perit Dial Int*. 2011a;31:34–38.
- Szeto CC, et al. Repeat peritonitis in peritoneal dialysis: retrospective review of 181 consecutive cases. *Clin J Am Soc Nephrol*. 2011b;6:827–833.
- Thodis E, et al. Decrease in *Staphylococcus aureus* exit-site infections and peritonitis in CAPD patients by local application of mupirocin ointment at the catheter exit site. *Perit Dial Int*. 1998;18:261–270.
- Troidle L, et al. Two gram intraperitoneal cefazolin for the treatment of peritonitis. *Perit Dial Int*. 1997;17(suppl 1):S40.
- Vychytil A, et al. Ultrasonography of the catheter tunnel in peritoneal dialysis patients: what are the indications? *Am J Kidney Dis*. 1999;33:722–727.
- Williams AJ, et al. Tenckhoff catheter replacement or intraperitoneal urokinase: a randomized trial in the management of recurrent continuous ambulatory peritoneal dialysis (CAPD) peritonitis. *Perit Dial Int*. 1989;9:65–67.
- Yu AW, et al. Neutrophilic intracellular acidosis induced by conventional lactate-containing peritoneal dialysis solutions. *Int J Artif Organs*. 1992;15:661–665.
- Zimmerman SW, et al. Randomized controlled trial of prophylactic rifampin for wwperitoneal dialysis-related infections. *Am J Kidney Dis*. 1991;18:225–231.

The instillation of dialysis fluid into the peritoneal cavity is accompanied by an increase in intra-abdominal pressure (IAP). The two principal determinants of its magnitude are dialysate volume and the position of the patient during the dwell. The supine position is associated with the lowest IAP for a given dialysate volume; sitting is associated with the highest. Furthermore, actions such as coughing, bending, or straining at stool transiently increase IAP. The increased IAP can lead to a variety of mechanical complications in peritoneal dialysis (PD) patients.

I. HERNIA FORMATION

A. **Incidence and etiologic factors.** The incidence and prevalence of hernias are difficult to assess. Hernias can be asymptomatic and may be missed on cursory examination. It has been suggested that as many as 10%–20% of patients may develop a hernia at some time on peritoneal dialysis.

Potential risk factors are listed in Table 28.1 and include large dialysate volumes and activities that involve isometric straining or the Valsalva maneuver. Furthermore, deconditioning of the musculature of the abdominal wall increases wall tension and predisposes to hernia formation.

TABLE

28.1

Potential Risk Factors for Hernia Formation

- Large dialysate volumes
- Sitting position
- Isometric exercise
- Valsalva maneuver (e.g., coughing, straining at stool)
- Recent abdominal surgery
- Pericatheter leak or hematoma
- Obesity
- Deconditioning
- Multiparity
- Congenital anatomical defects

Ventral
Epigastric
Pericatheter
Umbilical
Inguinal (direct and indirect)
Femoral
Foramen of Morgagni
Cystocele
Spigelian
Richter's
Enterocoele

- B. **Types of hernia.** Many different types of hernia have been described in the peritoneal dialysis patient. These are listed in Table 28.2.

Indirect inguinal hernias are the result of bowel and/or dialysate tracking through the processus vaginalis, which in some individuals has remained patent rather than undergoing normal obliteration. It is much more common in males. In boys, it is very likely that if one processus vaginalis is patent (causing inguinal hernia), then the other side is patent also, and repair (see below) should be done bilaterally.

- C. **Diagnosis.** As mentioned above, hernias can be clinically occult. To better detect them, it is often useful to have the patient stand and “bear down” as this increases IAP and makes a hernia more obvious. Pericatheter hernias need to be differentiated from masses caused by a hematoma, seroma, or abscess. Ultrasonography can distinguish the solid-appearing hernia from the fluid collections characterizing these other conditions. The scrotal fullness of an indirect inguinal hernia has in its differential diagnosis hydrocele (fluid/dialysate entering the scrotum through a patent processus vaginalis) and intrinsic scrotal or testicular pathology.

Delineation of a hernia can be aided by dye-assisted computed tomography (CT). First, 100 mL of Omnipaque 300 is added to a 2-L bag of dialysate and then instilled into the peritoneal cavity. **It is important that the patient then be as active and ambulatory as possible for the next 2 hours to facilitate the entry of dye into the hernia sacs.** CT scanning is then performed. In the case of inguinal hernias, it is important that the genitalia be scanned. The CT scan can indicate whether scrotal edema is the result of fluid tracking along a patent processus vaginalis or along the anterior abdominal wall (see below). This procedure can also help delineate anterior abdominal wall hernia from isolated leaks. In other types of hernia, such as umbilical hernia, CT scanning is not necessary because the diagnosis is usually obvious.

Magnetic resonance imaging may be useful in the diagnosis of abdominal wall and genital leaks, and it may be helpful in patients with allergy to conventional radiologic dye.

The dialysate itself looks bright white on the MRI images.

- D. **Treatment.** Small hernias, especially umbilical hernias, pose the greatest risk of incarceration or strangulation of bowel. These should be repaired surgically. The patient should be warned that if a hernia stops being reducible, and especially if it becomes tender, medical consultation should be sought immediately. **Any patient presenting with peritonitis should be examined for the presence of small strangulated hernias, as these can lead to transmural leakage of bacteria and peritonitis.** Large hernias can also be repaired surgically, as can cystocele and enterocele. Uterine prolapse (not really a hernia) can sometimes be managed with a pessary, but ultimately hysterectomy may be necessary.

After surgical repair of a hernia, IAP must be kept as low as possible to facilitate healing. If the patient has significant residual renal function (e.g., 10 mL/min or more), it may be possible to stop dialysis altogether for a week and then recommence with small volumes (e.g., 1 L). The patient must be watched for the development of uremic symptoms or hyperkalemia. If automated peritoneal dialysis (APD) is available, the patient can dialyze supine and hence with lower IAP. If there is little or no renal function, low-volume peritoneal dialysis should be started postoperatively. An alternative is to hemodialyze the patient until wound healing is more complete (2–3 weeks).

Options for the patient with recurrent hernias include a reduction in strenuous physical activity, more frequent dialysis exchanges with lower volumes, or transfer to hemodialysis.

If the patient is too ill or refuses surgery, mechanical support of the hernia can be effected with a corset or truss. The patient should be warned about symptoms of incarceration and strangulation.

II. **ABDOMINAL WALL AND PERICATHETER LEAK.** The precise incidence of these complications is also unknown, but they are less common than hernias. Risk factors are similar to those outlined in Table 28.1. Poor surgical technique may play a role in the development of pericatheter leak.

- A. **Diagnosis.** Abdominal wall leak may be difficult to diagnose clinically. It may be mistaken for ultrafiltration failure when dialysate returns are less than the instilled volume (see Chapter 21). Weight gain is common as the dialysate accumulates in the tissues of the abdominal wall. The diagnosis should be considered when there are decreased effluent volumes, weight gain, protuberant abdomen, and absence of generalized edema. The patient should stand during the examination as this may reveal asymmetry of the abdomen. The abdominal wall itself may have a “boggy” look, with deep impressions made by waist bands, dialysate tubing, etc.

Pericatheter leak is usually diagnosed by wetness (dialysate) on the exit site dressing. A urine dipstick placed on the wet part will test strongly positive for glucose. Diagnosis can be proven using contrast CT scanning as described under “Hernia formation” (Section I.C).

- B. **Treatment.** Pericatheter leak usually occurs as a postoperative complication of catheter implantation. The patient should be drained and peritoneal dialysis stopped for at least 24–48 hours. The longer the patient can be left off peritoneal dialysis, the greater the chance that the leak will seal itself. If necessary, the patient should receive hemodialysis, and peritoneal dialysis can be recommenced several days later. In most cases, the leak seals spontaneously. If it persists, the catheter should be removed and reinserted at another site,

and special care should be taken in catheter implantation. Antibiotic prophylaxis is not usually necessary for pericatheter leak unless there are obvious signs of infection.

In contrast to pericatheter leaks, abdominal wall leaks can occur early or late. APD in the supine position usually allows the dialysate accumulation to resolve. If the leak is the result of disruption of abdominal wall integrity, the patient should be converted to a day dry APD regimen or to hemodialysis. Sometimes, the abdominal wall defect heals after a transient course of day dry APD and continuous ambulatory peritoneal dialysis (CAPD) can then be resumed. Sometimes surgical repair is feasible.

Vaginal leaks can also occur. Other leaks can be due to dissection of dialysate through fascial defects and require patients to convert to day dry APD or hemodialysis.

III. GENITAL EDEMA

- A. **Pathogenesis.** Dialysate can reach the genitalia by two routes: One is by traveling down a patent processus vaginalis to the *tunica vaginalis*, resulting in hydrocele. In this first route, the dialysate can also dissect through the walls of the *tunica vaginalis*, causing edema of the scrotal (or, less commonly, labial) wall itself. The second route is through a defect in the abdominal wall, often associated with the catheter tract. In this instance, the dialysate tracks inferiorly along the abdominal wall. This leads to edema of the foreskin and scrotum, or mons pubis.
- B. **Diagnosis.** This complication is often painful and distressing to the patient who will be quick to bring it to medical attention. CT peritoneography should be performed to distinguish which route has led to the genital swelling (i.e., anterior abdominal wall or processus vaginalis). Alternatively, 3–5 mCi of technetium-labeled albumin colloid can be injected into the dialysate and infused into the patient, and the route of leakage traced by scintigraphy.
- C. **Treatment.** Peritoneal dialysis should be temporarily stopped. Bed rest and scrotal elevation are helpful. Depending on the need, temporary APD with low volumes and with the patient supine can often be used without causing reaccumulation of genital edema. If necessary, hemodialysis can be used temporarily.

A leak via a patent processus vaginalis can be repaired surgically. If the leak is through the anterior abdominal wall, replacement of the catheter may be required. APD in the supine position with low volume or no day dwell allows lower IAP and decreases the chances of recurrent leakage.

IV. RESPIRATORY COMPLICATIONS

- A. **Hydrothorax.** Under the influence of raised IAP, dialysate can travel from the peritoneal to the pleural cavity, leading to a pleural effusion composed of dialysis effluent. This complication is termed hydrothorax.
 1. **Incidence and etiologic factors.** The incidence of hydrothorax is unknown because the pleural effusion may be small and asymptomatic. It is less common than hernia.

There are defects in the hemidiaphragm that allow passage of dialysate. These defects may be congenital, in which case hydrothorax can occur with the first dialysis exchange, or acquired, in which case hydrothorax can be a late complication.

Hydrothorax occurs almost exclusively on the right side, probably because the left hemidiaphragm is mostly covered by the heart and pericardium.

2. **Diagnosis.** Symptoms of hydrothorax range from asymptomatic pleural effusion to severe shortness of breath. Acute shortness of breath at the beginning of PD therapy should suggest this diagnosis. Thoracentesis can be done for diagnosis and/or to relieve symptoms. The most diagnostic feature of the pleural fluid is a very high glucose level, although this is often not found. It is otherwise typically transudative, with variable numbers of leukocytes.

Radionuclide scanning with technetium may be helpful. Technetium-labeled albumin colloid (5 mCi) is added to a dialysate bag, which is then infused into the patient. Posterior views are taken at 0, 10, 20, and 30 minutes and an anterior view at 30 minutes. It is important that the patient be ambulatory while the instilled tracer is dwelling to increase IAP and flux into the pleural cavity. Late (2–3 hours) views may be necessary if the movement of the tracer into the pleural cavity is not detected by gamma camera in earlier shots. CT scanning with intraperitoneal dye can also be used.

3. **Treatment.** If there are respiratory symptoms, peritoneal dialysis should be stopped immediately. Thoracentesis may be necessary; in which case, the diagnosis can be made by measuring glucose in the pleural fluid.

Definitive treatment entails repair of defects in the hemidiaphragm or obliteration of the pleural space (pleurodesis). Rarely, the dialysate itself acts as an irritant in the pleural cavity and causes pleurodesis, so that peritoneal dialysis can be resumed 1–2 weeks later. APD with low IAP (small volumes, supine position) can sometimes be carried out without recurrence. The movement of fluid into the pleural space is pressure-driven, so leaving the patient in the supine position is helpful. Surgical options for treatment of hydrothorax are listed in Table 28.3.

TABLE

28.3

Surgical Options for Treatment of Hydrothorax

Pleurodesis

Talc

Oxytetracycline

Autologous blood

Aprotonin–fibrin glue

Repair of hemidiaphragm

Oversewing defects

Reinforcement with patches

- B. **Altered mechanics of breathing.** Pulmonary function is unchanged with peritoneal dialysis, except for a mildly decreased functional residual capacity. Arterial oxygenation has been observed to decrease slightly and transiently with start of CAPD.

Peritoneal dialysis does not worsen respiratory symptoms in patients with obstructive

pulmonary disease. The tonic stretch placed on the diaphragm by the raised IAP may actually facilitate the mechanics of breathing in these patients.

V. BACK PAIN

- A. **Pathogenesis.** The presence of dialysate in the peritoneal cavity both raises IAP and swings the body's center of gravity forward, producing lordotic stress on the lumbar vertebrae and paraspinal muscles. In predisposed individuals, the altered spinal mechanics can lead to exacerbation of sciatica or posterior facet symptoms. Lax anterior abdominal musculature will exacerbate this effect.
- B. **Treatment.** Bed rest and analgesia are important when symptoms are acute. Some patients benefit by the performance of more frequent exchanges with smaller dialysate volumes. If possible, APD with a small or no day dwell is advisable for these patients because dialyzing supine removes the lordotic stress on the lumbar spine. Ideally, the patient should undertake abdomen and back strengthening exercises, but this is not always feasible.

VI. **OVERFILL.** Overfill is defined as a clinical event in which symptoms of raised IAP occur acutely in association with a very high dwell volume to fill volume ratio. It is most likely to be significant if the ratio exceeds 2.0, for example, a 4-L end-dwell volume in a patient whose fill volume is 2 L. Symptoms typically include acute abdominal discomfort or shortness of breath. Most episodes result from situations where dialysis solution volume is infused without adequate drainage of the previous dwell volume. This may be accidental, but more often it is associated with poor catheter outflow function. A large volume of ultrafiltrate may also contribute. Significant overfill is more common in children, in patients on APD, especially when tidal prescriptions are being used and in those in whom minimum drain alarms are turned off. Newer cyclers make it more difficult to initiate cycling without a complete drain of the day dwell and also have precautions in place to drain cumulative ultrafiltrate. Asymptomatic overfill episodes are probably quite common. Rarely, deaths have been associated with severe overfill.

VII. ENCAPSULATING PERITONEAL SCLEROSIS

- A. **Incidence and etiologic factors.** Encapsulating Peritoneal Sclerosis (EPS) is a rare but devastating complication of long-term PD that has been reported to occur in 1%–3% of patients. There is an early inflammatory phase associated with vague abdominal discomfort, a change to a rapid transport status, bloody effluent, and signs of inflammation, including erythropoietin-resistant anemia and elevated C-reactive protein. The inflammatory phase can progress, either with or without a “second hit” such as peritonitis, to a sclerosing phase where a fibrotic cocoon slowly encapsulates the small bowel. In this second phase, the patient typically shows weight loss and recurrent bowel obstruction.

The strongest risk factor for EPS is the duration of PD therapy. Although the overall incidence is low, it becomes significant after 5 years and even more so after 10 years. Young age at onset of PD is also an independent risk factor. Patients who have transitioned to hemodialysis or renal transplant are still vulnerable.

There is no reliable association of EPS with the type or number of episodes of PD peritonitis, or with the type or strength of PD solutions used. Patients with underlying

autoimmune/inflammatory disease such as lupus or vasculitis may be predisposed.

- B. **Diagnosis and treatment.** The inflammatory phase of EPS should be considered when a long-term PD patient presents with new bloody effluent, inflow or outflow pain, or generalized abdominal discomfort. The sclerosing phase is suggested by recurrent bowel obstruction. As mentioned, the patient may no longer be on PD. Inflammatory markers may be elevated.

Imaging is helpful in the sclerosing phase, where cocooning of the bowel is seen, in conjunction with thickening, tethering, enhancement, and calcification of the peritoneal membrane. **Thickening of the peritoneal membrane is seen in any long-term PD patient and, by itself, is not diagnostic of EPS.** Regular CT surveillance of long-term patients has not been shown to be helpful.

The inflammatory phase of EPS is best treated with modest doses of corticosteroid. Infective causes should be ruled out before contemplating this therapy. The duration of treatment is unclear and could be titrated to the symptoms. Some studies have suggested the addition of tamoxifen or mTor inhibitors for their antifibrotic effects. As in any sclerosing condition, there is a better therapeutic window during the inflammatory phase than when there is already extensive scar formation.

It is not clear whether the patient should be transitioned to hemodialysis. On the one hand, it reduces continuing exposure to the process that led to the EPS. On the other hand, leaving the abdomen dry stops the “washout” of inflammatory mediators that PD affords.

In the patient with an established abdominal cocoon and recurrent bowel obstruction, surgery may be necessary. It is very important to consult a surgeon who is familiar with the operative approach to this kind of patient, as the risk of bowel tear, fecal peritonitis, and operative mortality are all high.

References and Suggested Readings

- Balda S, et al. Impact of hernias on peritoneal dialysis technique survival and residual renal function. *Perit Dial Int.* 2013;33:629–634.
- Chow KM, et al. Management options for hydrothorax complicating peritoneal dialysis. *Semin Dial.* 2003;16:389–394.
- Cizman B, et al. The occurrence of increased intraperitoneal volume events in automated peritoneal dialysis in the U.S.: role of programming, patient/user actions and ultrafiltration. *Perit Dial Int.* 2014;34:434–442.
- Davis ID, et al. Relationship between drain volume /fill volume ratio and clinical outcomes associated with overfill complaints in peritoneal dialysis episodes. *Perit Dial Int.* 2011;31:148–155.
- Dimitriadis CA, Bargman JM. Gynecologic issues in peritoneal dialysis. *Adv Perit Dial.* 2011;27:101–105.
- Goldstein M, et al. Continuous ambulatory peritoneal dialysis: a guide to imaging appearances and complications. *Insights Imaging.* 2013;4:85–92.
- Goodlad C, et al. Screening for encapsulating peritoneal sclerosis in patients on peritoneal dialysis: role of CT scanning. *Nephrol Dial Transplant.* 2011;26: 1374–1379.

- Lew SQ. Hydrothorax: pleural effusion associated with peritoneal dialysis. *Perit Dial Int.* 2010;30:13–18.
- Martinez-Mier G, et al. Abdominal wall hernias in end-stage renal disease patients on peritoneal dialysis. *Perit Dial Int.* 2008;28:391–396.
- Prischl F, et al. Magnetic resonance imaging of the peritoneal cavity among peritoneal dialysis patients, using the dialysate as “contrast medium.” *J Am Soc Nephrol.* 2002;13:197–203.
- Shah H, Chu M, Bargman JM. Perioperative management of peritoneal dialysis patients undergoing hernia surgery repair without the use of interim hemodialysis. *Perit Dial Int.* 2006;26:684–687.

While peritoneal dialysis (PD) provides effective control of many of the diverse consequences of uremia, the therapy itself has unique effects on several metabolic parameters that are important for the health of patients with end-stage renal disease.

I. **HYPERGLYCEMIA:** With PD, ultrafiltration is induced by exerting either crystalloidal osmotic or oncotic pressure across the peritoneal barrier. This is achieved with PD solutions that contain supraphysiologic concentrations of glucose; some prescriptions also include once-daily treatment with either icodextrin or amino-acid-based dialysis solution. Each one of these substances is absorbed systemically during the course of the PD dwell leading to systemic metabolic effects. Treatment with glucose- or icodextrin-based PD solutions results in an obligatory daily absorption of 50–150 g of carbohydrates. This obligatory carbohydrate absorption is higher with greater use of more hypertonic solutions, and in individuals with a faster peritoneal solute transfer rate. Absorbed icodextrin is metabolized, not to glucose but to a variety of oligosaccharides and to the disaccharide maltose (Moberley, 2002)

In some individuals with diabetes mellitus, this obligatory absorption results in poorer glycemic control and requires significant adjustments in therapy. These may include an increase in total daily insulin dose, or initiation of insulin or other glucose-lowering therapy for individuals who did not previously need such treatment. Hence, it is imperative to increase the intensity of home glucose monitoring in diabetic patients for the first few weeks after initiating PD, or whenever the prescribed tonicity of glucose-based dialysate is increased. Worse glycemic control is associated with worse outcomes in PD patients, but it is unclear whether this is association or cause and effect (Duong, 2011). There are limited data to determine how much PD increases the incidence of new-onset diabetes, but one Chinese study suggests that about 8% of nondiabetic patients become diabetic (Szeto, 2007). Therefore, blood glucose levels should also be measured every 1–3 months in nondiabetic PD patients.

Just as glucose-based dialysis solutions may worsen glycemic control, glucose-sparing regimens may improve it. These glucose-sparing regimens generally comprise substitution of one glucose-based exchange with icodextrin; the greater ultrafiltration with icodextrin during the long dwell may allow for the use of lower concentrations of glucose for the other dwells (Paniagua 2008). Substituting a second glucose-based exchange with amino-acid dialysate allows for further reduction in systemic glucose absorption. In IMPENDIA, a recently completed randomized trial, the HbA1c of individuals treated with a regimen in which two bags

of glucose-based exchange were substituted with one bag each of icodextrin and amino-acid dialysate was 0.6% lower compared with individuals treated entirely with glucose-based dialysate (Li, 2013). Glucose-sparing regimens should be considered in individuals with diabetes treated with PD when there is difficulty in achieving glycemic control.

II. WEIGHT GAIN: The effects of increased body weight in PD are complex. In hemodialysis patients, increased body weight is associated with improved survival, but the evidence is conflicting in PD patients, and there is a concern that obesity may predispose to catheter problems and exit site infection (Johnson, 2012). Patients often gain weight after initiation of dialysis irrespective of modality; this generally reflects gain in fat rather than in lean body mass. This weight gain is, at least in part, a result of increased dietary energy and protein intake following the amelioration of uremic anorexia with initiation of dialysis. In patients treated with PD, some of the weight gain is attributed to the obligatory systemic carbohydrate absorption. However, large head-to-head comparisons do not support the notion that patients treated with PD are more likely to gain significant weight when compared with individuals treated with hemodialysis (Lievense, 2012). Replacing glucose with icodextrin for the long day dwell in automated PD (APD) or for the night dwell in continuous ambulatory PD (CAPD) results in smaller gains in body weight, but this could reflect differences in total body water rather than body fat. Limited evidence suggests that the sites for deposition of excess body fat differ by dialysis modality with greater gain in visceral fat in PD patients; the clinical relevance of this is unclear (Choi, 2011). Despite this uncertainty, it is prudent to limit exposure to more hypertonic glucose dialysis solutions in order to avoid excessive weight gain.

III. PERITONEAL PROTEIN LOSS: During PD, proteins in the blood—primarily albumin—move into the dialysate down their concentration gradient across the peritoneal barrier and are lost as the dialysate is drained. The daily peritoneal protein loss with PD averages 6–8 g and is substantially increased during episodes of peritonitis. As a result of this obligatory daily loss, serum albumin may decrease in patients starting treatment with PD and is often lower than in individuals undergoing hemodialysis.

This daily peritoneal protein loss is generally not modifiable, and its clinical relevance remains unclear. The evidence associating the higher daily peritoneal protein loss with all-cause mortality, cardiovascular events, or protein-energy wasting is, at best, inconsistent (Balafa, 2011). Moreover, the lower serum albumin in patients treated with PD does not seem to put these patients at any higher risk than patients undergoing hemodialysis. All these considerations suggest that PD can be safely continued in patients that are otherwise well but have modest decrements in serum albumin levels with the therapy.

IV. LIPID ABNORMALITIES: Dyslipidemia is highly prevalent in patients undergoing maintenance dialysis and reflects the net effects of the uremic state, underlying causes of kidney disease (e.g., diabetic nephropathy, other proteinuric renal diseases), and the potential disparate effects of the dialysis modality. The obligatory carbohydrate absorption and peritoneal protein loss with PD can adversely influence the lipid profile of PD patients. The lipid abnormalities described in PD patients include increases in total and low-density cholesterol, triglycerides, lipoprotein(a),

and apolipoprotein B (Prichard, 2006).

The contribution of lipid abnormalities to the high cardiovascular risk in patients treated with PD is presently unknown. The Study of Heart and Renal Protection (SHARP) is the only clinical trial examining the impact of lipid lowering on cardiovascular events and mortality that has included patients undergoing PD; of the 9270 enrolled subjects, 496 were undergoing PD at the time of enrollment. While treatment with simvastatin/ezetimibe was associated with fewer cardiovascular events in this clinical trial, there was no significant effect on either all-cause or cardiovascular mortality (Baigent, 2011). Specifically, there was no significant difference in outcomes in the subgroup treated with PD. This trial suggests that the clinical benefit from lipid lowering may not be as large in patients with kidney disease, including those undergoing PD, as in the general population. It is important, however, to note that severe hypertriglyceridemia is also associated with a higher risk for pancreatitis in PD patients and so may warrant treatment to reduce this risk.

Limited data indicate that drug therapies are as effective in improving dyslipidemia in patients treated with PD as in the general population. Some studies have also examined whether modifications in the PD prescription can improve lipid abnormalities. Substituting one glucose-based exchange with icodextrin has been shown to have a modest effect on serum total cholesterol. In the IMPENDIA trial, a glucose-sparing regimen that included one exchange each with icodextrin and amino acids-based PD solution resulted in a significant decrease in both serum triglycerides and apolipoprotein B (Li, 2013). These modifications to the PD regimen may be considered in selected individuals for the treatment of these lipid abnormalities.

V. HYPOKALEMIA/HYPERKALEMIA: Ten to 30 percent of patients treated with PD are reported to have low serum potassium levels. There are several potential reasons for this high prevalence of hypokalemia. These include greater potassium removal with dialysis since PD solutions have no added potassium, inadequate dietary intake, transcellular shift induced by insulin released in response to the obligatory glucose absorption, renal losses in patients treated with diuretics, and gastrointestinal losses with use of laxatives (Zanger, 2010).

Observational studies have demonstrated that hypokalemia is associated with a higher risk for gram-negative peritonitis and an increase in risk for all-cause, cardiovascular, and infection-related mortality in patients undergoing PD (Torlen, 2012). Whether correction of hypokalemia ameliorates any of these risks is not known. Oral administration of potassium supplements is probably the easiest and safest way to correct hypokalemia. While intraperitoneal administration of injectable potassium chloride can correct hypokalemia, it exposes patients to a higher risk of peritonitis from touch-contamination. Even though it is appealing to consider mineralocorticoid receptor antagonists such as spironolactone, there is no significant effect on serum potassium levels in patients undergoing PD treated with these agents. Significant hyperkalemia is uncommon in PD and is typically related to nonadherence to the PD prescription.

VI. METABOLIC ACIDOSIS: Progressive loss of excretory function in chronic kidney disease is associated with reduced renal acid excretion. Hence, metabolic acidosis is frequently present in patients at the time of starting dialysis. Conventional glucose- and icodextrin-based PD

solutions contain lactate as the buffer. During treatment with such solutions, bicarbonate enters the peritoneal cavity and is removed with each exchange, while lactate is absorbed systemically. The absorbed lactate is metabolized to bicarbonate, and this corrects the uremic metabolic acidosis. Bicarbonate-based PD solutions are available commercially in some parts of the world; in patients treated with these solutions, the systemic absorption of bicarbonate is responsible for the correction of metabolic acidosis.

Regardless of the buffer used, PD provides a more complete correction of metabolic acidosis than thrice-weekly in-center hemodialysis. Yet the correction remains incomplete in a significant minority of PD patients. There is evidence that uncorrected metabolic acidosis contributes to protein-energy wasting and osteopenia. Recent observational studies have also demonstrated a higher risk for all-cause or cardiovascular mortality in PD patients with persistently low serum bicarbonate levels (Vasishta, 2013). These data argue for treatment of persistent metabolic acidosis in patients undergoing PD.

A number of clinical trials have tested the clinical benefits with treatment of metabolic acidosis in PD patients (Mehrotra, 2009; Stein, 1997). These studies indicate that such treatment is associated with higher net positive nitrogen balance, significant weight gain, an increase in mid-arm circumference, and a reduction in hospitalizations. Whether treatment of metabolic acidosis has any effect on the risk of death of patients undergoing maintenance dialysis is unknown. In patients undergoing PD, oral administration of sodium bicarbonate is the most effective way to correct metabolic acidosis and should be used to achieve a serum bicarbonate level of at least 22 mmol/L.

VII. HYPO/HYPERNATREMIA: Hyponatremia is quite common in PD patients, and one center recently reported a prevalence of 15% (Dimitriadis, 2014). Translocational hyponatremia (due to movement of sodium-poor fluid from cells to extracellular fluid) can occur due to hyperglycemia, with the serum sodium falling about 1.3 mmol/L for each 6 mmol/L rise in blood glucose. Icodextrin causes a 2–3 mmol/L fall in serum sodium by the same mechanism. Dilutional hyponatremia in dialysis patients is generally thought to reflect excessive water intake, but recent studies in PD suggest it is more often a marker of decreased intracellular mass and is associated with weight loss, potassium depletion, and malnutrition. (Cherney, 2001; Dimitriadis, 2014). It should therefore be an indication for nutritional assessment of the patient. Rarely, hyponatremia can be factitious when serum sodium is measured by flame photometry in the presence of severe hypertriglyceridemia.

In contrast, treatment with PD has the potential to induce hypernatremia. In patients treated with PD, fluid is removed either through aquaporins or through interendothelial spaces in the peritoneal capillaries (See Chapter 21). The relative contribution of aquaporins to fluid removal is greatest early in the course of a PD dwell, and this is not associated with any concomitant removal of sodium or other solutes. APD prescriptions with short dwell times, particularly with hypertonic dialysate, have the potential therefore to remove more water relative to sodium, and this can result in hypernatremia. While the prevalence of hypernatremia with contemporary PD solutions and regimens is not known, >10% of patients treated with hourly exchanges using hypertonic PD solutions developed hypernatremia. Hypernatremia can induce thirst and stimulate greater fluid intake, and it is prudent to avoid frequent exchanges

with hypertonic dialysate when prescribing PD.

VIII. ABNORMALITIES IN MINERAL METABOLISM: For a discussion of the full range of abnormalities in mineral metabolism, see Chapter 36. Discussion here is limited to issues specific to PD. Studies done almost two decades ago indicated that patients treated with PD were significantly more likely to have adynamic bone disease than individuals undergoing maintenance hemodialysis. Small and relatively low-quality studies indicated that this risk could be ameliorated with the use of low-calcium dialysate (2.5 meq/L [1.25 mM]). The overwhelming majority of patients are now treated with low-calcium PD solutions, and there is increasing use of phosphate binders that do not contain elemental calcium, so the situation has changed. There are no contemporary studies that have examined bone histology in patients undergoing PD, and hence the current prevalence of adynamic bone disease is unclear.

References and Suggested Readings

- Baigent C, et al. The effects of lowering LDL cholesterol with simvastatin plus ezetimibe in patients with chronic kidney disease (Study of Heart and Renal protection): a randomized placebo-controlled trial. *Lancet*. 2011;377:2181–2192.
- Balafa O, et al. Peritoneal albumin and protein losses do not predict outcomes in peritoneal dialysis patients. *Clin J Am Soc Nephrol*. 2011;6:561–566.
- Cherney DZ, et al. A physiological analysis of hyponatremia: implications for patients on peritoneal dialysis. *Perit Dial Int*. 2001;21:7–13.
- Choi SJ et al. Changes in body fat mass after starting peritoneal dialysis. *Perit Dial Int*. 2011;31:67–73.
- Dimitriadis C, et al. Hyponatremia in peritoneal dialysis: epidemiology in a single center and correlation with clinical and biochemical parameters. *Perit Dial Int*. 2014;34:260–270.
- Duong U, et al. Glycemic control and survival in peritoneal dialysis patients with diabetes mellitus. *Clin J Am Soc Nephrol*. 2011;6:1041–1048.
- Fried L, et al. Recommendations for the treatment of lipid disorders in patients on peritoneal dialysis. ISPD guidelines/recommendations. *Perit Dial Int*. 1999;19:7–16.
- Johnson DW. What is the optimal fat mass in peritoneal dialysis patients? *Perit Dial Int*. 2007;27(suppl 2):S250–S254.
- Li PK, et al. Randomized controlled trial of glucose sparing peritoneal dialysis in diabetic patients. *J Am Soc Nephrol*. 2013;24:1889–1900.
- Lievens H, et al. Relationship of body size and initial dialysis modality on subsequent transplantation, mortality and weight gain of ESRD patients. *Nephrol Dial Transplant*. 2012;27:3631–3638.
- Mehrotra R, et al. Effect of high-normal compared with low-normal arterial pH on protein balances in automated peritoneal dialysis patients. *Am J Clin Nutr*. 2009;90:1532–1540.
- Mehrotra R, et al. Adverse effects of systemic glucose absorption with peritoneal dialysis: How good is the evidence? *Curr Opin Nephrol Hypertens*. 2013;22:663–668.
- Moberley JB, et al. Pharmacokinetics of icodextrin in peritoneal dialysis patients. *Kidney Int Suppl*. 2002;81:S23–S33.
- National Kidney Foundation. K/DOQI Clinical Practice Guidelines for managing dyslipidemias in

chronic kidney disease. http://www.kidney.org/professionals/KDOQI?guidelines_lipids/toc.htm (Last accessed, August 25, 2014).

Paniagua R, et al. Icodextrin improves fluid and metabolic management in high and high-average transport patients. *Perit Dial Int*. 2009;29:422–432.

Prichard SS. Management of hyperlipidemia in patients on peritoneal dialysis: current approaches. *Kidney Int Suppl*. 2006;103:S115–S117.

Stein A, et al. Role of an improvement in acid base status and nutrition in CAPD patients. *Kidney Int*. 1997;52:1089–1095.

Szeto CC, et al. Oral sodium bicarbonate for the treatment of metabolic acidosis in peritoneal dialysis patients: a randomized placebo-control trial. *J Am Soc Nephrol*. 2003;14:2119–2126.

Szeto CC, et al. New onset hyperglycemia in nondiabetic chinese patients started on peritoneal dialysis. *Am J Kidney Dis*. 2007;49:524–532.

Torlen K, et al. Serum potassium and cause-specific mortality in a large peritoneal dialysis cohort. *Clin J Am Soc Nephrol*. 2012;7:1272–1284.

Vashishta T, et al. Dialysis modality and correction of metabolic acidosis: relationship with all-cause and cause-specific mortality. *Clin J Am Soc Nephrol*. 2013;8:254–264.

Zanger R. Hyponatremia and hypokalemia in patients on peritoneal dialysis. *Semin Dial*. 2010;23:575–580.

PART IV

CLINICAL PROBLEM AREAS

Patients with end stage kidney disease (ESKD) are affected by numerous psychosocial stressors. These include effects of illness and treatment, functional limitations and sexual dysfunction, dietary restrictions, time constraints, and fear of death. In addition, there may be marital conflict, strained interpersonal relationships with family and administrative or medical personnel, and socioeconomic concerns regarding costs of treatment and unemployment.

Approximately 10% of ESKD patients who are hospitalized have an underlying psychiatric disorder. Hospitalization rates for psychiatric disorders are high relative to other chronically ill patients. Common problems include depression, dementia and delirium, psychosis, personality and anxiety disorders, and substance abuse.

- I. **DEPRESSION.** Depression is the most common, as well as the most important, problem because of the risk of resulting noncompliance with the dialysis and/or medication regimen and the risk of suicide. Depression may be widely underdiagnosed and untreated. According to the most recent version of the Diagnostic and Statistical Manual for Mental Disorder (DSM 5), a major depressive disorder should be diagnosed if, during a period of at least 2 weeks, a patient experiences depressed mood nearly every day or loss of interest/pleasure in usual activities and at least four of the following additional symptoms: (a) significant weight loss or weight gain or appetite disturbance, (b) change in sleep pattern, including insomnia or hypersomnia, (c) psychomotor agitation or retardation, (d) fatigue, (e) feelings of worthlessness or excessive guilt, (f) decreased concentration, or (g) recurring thoughts of death or suicide. The last criterion, (g), is probably the most specific, as some of the others are associated with uremia per se.

Some investigators have estimated that depression occurs in as many as 10%–50% of dialysis patients. Screening tools include the Beck Depression Inventory (BDI) and the Hamilton Rating Scale for Depression. In patients with no underlying medical problems, a BDI score <9 suggests no or minimal depression, 10–18 indicates mild to moderate depression, 19–29 moderate to severe depression, and ≥ 30 severe depression. In patients with ESKD, the recommended cutoff scores for depression are higher, with BDI scores ≥ 14 –16 indicating significant disease.

Screening for underlying depression in the dialysis population is an important element of the treatment plan. Depressive affect can influence medical outcomes in several ways. In addition to the risk of suicide, depression may lead to poor compliance with the dialysis

prescription, to abnormal immunologic function, or to anorexia and poor nutritional status. Depressive affect has also been linked to a higher incidence of peritonitis. Whether depression increases mortality risk is controversial. Some studies have suggested that baseline depressive symptomatology is associated with increased mortality, even after multiple medical risk factors have been accounted for in analyses.

ESKD patients can display suicidal behavior differently from patients with other chronic illnesses. Their rate of suicide is higher than in the general U.S. population. Important risk factors include a previous history of mental illness, recent hospitalization, age >75, male gender, white or Asian race, and alcohol or drug dependence. ESKD patients presumably can commit or attempt suicide more easily either through noncompliance with their medical regimen or by manipulating their dialysis access sites.

A. **Treatment options.** Treatment options for depression include pharmacotherapy, psychotherapy, including cognitive behavioral therapy, and electroconvulsive therapy. Unfortunately, there are limited data on the effects of antidepressants in patients with ESKD, since these patients are often excluded from many of the large clinical trials.

1. **Pharmacotherapy**

a. **Selective serotonin reuptake inhibitors (SSRIs) and tricyclic antidepressants (TCAs).** Treatment with SSRIs should be continued for at least 4–6 weeks before deciding whether there has been a therapeutic benefit. If efficacy is not achieved, then a switch to another antidepressant of the same class or a different class is a reasonable step. SSRIs are advantageous because they typically cause fewer anticholinergic symptoms than TCAs, and are not associated with cardiac conduction abnormalities. Furthermore, TCAs can cause death if taken in large doses and hence pose a potential suicide risk. However, there is a potential for increased bleeding in patients taking SSRIs, which may be relevant to patients with ESKD and preexisting qualitative platelet defects from uremia. SSRIs may also worsen nausea and vomiting, which are common symptoms in the dialysis patient population.

Typically, SSRIs are cleared by the liver and are highly protein bound. It has been recommended that the dose of SSRI in patients with ESKD should be reduced to two-thirds of the usual amount. SSRIs may have an additional benefit of reducing postural and intradialytic hypotension through effects on vascular tone. Fluoxetine, the first available SSRI, is the best studied drug in this family. A dose of 20 mg of fluoxetine daily is usually well tolerated, although data are limited to the short term. Other medications in this same family include paroxetine, sertraline, and citalopram.

b. **Selective norepinephrine reuptake inhibitors (SNRIs).** Venlafaxine and bupropion hydrochloride are examples of a different class of antidepressants called SNRIs. The SNRIs should be used with caution in ESKD patients, since these drugs are primarily renally excreted. Bupropion has active metabolites that are almost completely removed by the kidney. These metabolites may accumulate in dialysis patients, predisposing them to developing seizures.

c. **Monoamine oxidase inhibitors (MAOIs).** MAOIs have numerous side effects and should

be avoided if possible in ESKD patients, because of their potential to cause hypotension.

2. **Nonpharmacologic options.** There are several forms of psychotherapy (cognitive behavioral therapy [CBT], interpersonal, supportive, and group therapy) that might be effective in managing psychological distress. There are few data on such treatments in patients with chronic kidney disease. Individual psychotherapy (cognitive-behavioral, interpersonal, and supportive) is useful when the patient has identified that there is a problem and has accepted encouragement by the clinician to seek treatment. A recent randomized crossover trial of 65 hemodialysis patients showed significant improvements in depression scores as measured by the Beck Depression Inventory II (BDI II) and the Hamilton Depression Rating Scale in those patients who received CBT. With CBT, there was also an improvement in quality-of-life scores and a reduction in interdialytic weight gain. Denial is common and is a way of coping with uncomfortable thoughts or feelings related to being a “dialysis patient.” When a patient is noncompliant with treatment, denial might play a part in such behavior. Such patients may benefit from psychiatric interventions. However, these patients may resist treatment, as the implication is that “there is something wrong” with them. Motivating a patient to accept these forms of therapy may be difficult. Introducing therapy as a stress management approach to living with ESKD might be one approach to ease the patient into appropriate treatment. Supportive psychotherapy in conjunction with pharmacologic treatment is important for decreasing the rate of relapse. Group therapy may also have a positive impact. One uncontrolled study showed participation in group therapy sessions at the dialysis unit was associated with improved patient survival. Finally, electroconvulsive therapy may be used for patients with severe refractory depression, provided that there are no contraindications.

II. DEMENTIA/DELIRIUM. Neurocognitive disorders are common in ESKD patients. Cognitive deficits may be related to underlying uremia or other coexistent underlying medical conditions, as described in more detail in Chapter 40. Physicians should initiate discussions with the family about cessation of dialysis in patients with progressive dementia. Withdrawal from dialysis is relatively common, especially in elderly patients or patients who fail to thrive. Advanced directives should be offered to patients at the initiation of renal replacement therapy, ideally before the onset of any disease that would impair their capacity for decision making. The guidelines regarding shared decision making endorsed by the U.S. Renal Physicians Association are a helpful resource.

III. ANXIETY AND BEHAVIOR DISORDERS. Anxiety disorders can be frequent in patients with ESKD and are associated with lower patient perception of quality of life. There was a 45% prevalence of anxiety disorders in a single center study of 70 hemodialysis patients. Disruptive behavior directed toward the dialysis staff occurs in a minority of patients, but nevertheless can be a disturbance to all those in the dialysis unit. It is important to try to understand why the patient is angry and to explore potential solutions. Anxiety states should be treated through psychotherapy and behavioral techniques. Setting limits or establishing boundaries is paramount when hostility

or aggression poses a threat of harm to the patient or to others. Hostility and aggressive behaviors might be manifestations of an underlying psychiatric symptom, such as paranoia, referential thinking, or even conditions associated with delirium. If doubt about a particular patient exists, consultation with a psychiatrist should be sought.

If these measures are not effective, short-acting benzodiazepines such as lorazepam or alprazolam may be prescribed for limited periods. These benzodiazepines are metabolized by the liver. Nevertheless, as with the SSRIs, it is prudent to start with lower doses. The use of diazepam and chlordiazepoxide should be avoided in dialysis patients, owing to their metabolism to pharmacologically active metabolites. Barbiturates should not be used in place of benzodiazepines, since the long-acting ones are removed by hemodialysis. For the acutely agitated patient, antipsychotic medications, such as haloperidol, are sometimes required. Haloperidol is not renally cleared; therefore, no dose adjustment is usually necessary. Little is known about the effects of other atypical antipsychotics, such as risperidone or olanzapine, in this patient population. Gabapentin is currently used to treat anxiety, but it does not have U.S. Food and Drug Administration approval for this indication. Gabapentin is eliminated by renal excretion as an unchanged drug. In patients with ESKD, the plasma clearance of gabapentin is reduced. ESKD and CKD patients with bipolar disorders requiring lithium should have serum lithium levels checked frequently. Lithium is cleared by dialysis; therefore, the dose should be given after each dialysis treatment. Valproic acid is another mood stabilizer sometimes used to treat bipolar disorder. Free serum levels of this drug have been observed to be elevated in patients with impaired renal function. Caution should be exercised in the administration of glucocorticoids to potential renal transplant patients with a history of psychosis, because of the risk of steroid-induced psychosis. Other steroid-sparing agents should be used if clinically feasible.

IV. OTHER PSYCHOSOCIAL ISSUES IN THE ESKD POPULATION

- A. **Marital issues.** There have been only a few studies that assess marital relationships in ESKD patients. One study found that more than 50% of couples that included a patient with ESKD experienced marital discord. Marital conflict may be an important stressor for ESKD patients. Marital conflict may be associated with a patient's perception of burden of illness and the degree to which a patient does not adhere to the dialysis prescription. Marital satisfaction and conflict may be particularly salient for female patients. One study showed that female ESKD patients treated with hemodialysis with higher levels of marital satisfaction had improved survival. Marital satisfaction was not associated with differential outcomes in men.
- B. **Sexual dysfunction.** ESKD patients have a high prevalence of sexual dysfunction, owing to the effects of uremia, neuropathy, autonomic dysfunction, vascular disease, depression, and medications. Disturbances in the hypothalamic–pituitary–gonadal axis are also frequently encountered. Problems include decreased libido, erectile dysfunction, menstrual disorders, and infertility. Impotence is believed to occur in roughly 70% of men treated with dialysis, and men about to initiate dialysis should be counseled regarding the possibility of erectile dysfunction. This may lead to better communication with the physician and therefore reduce the possibility of depression. Women treated with dialysis commonly have disturbances in

fertility and menstruation. Irregular menstrual cycles are common after the initiation of hemodialysis treatment. The most common menstrual disorder in women with ESKD is anovulation. For information about treatment, see Chapter 39.

- C. **Socioeconomic issues.** More than half of ESKD patients do not continue working after beginning renal replacement therapy. Those holding professional occupations may have greater flexibility in their work schedules and may be more likely to continue employment. Unemployment can have a significant psychologic impact on the individual, possibly contributing to a greater likelihood of depression.
- D. **Rehabilitation.** Exercise may play an important role in improving a patient's overall sense of well-being. Specially designed exercise programs are available for those with physical impairments, and these should be promoted at the dialysis center or during routine physician visits. Other therapeutic modalities to consider are stress reduction/relaxation exercises and biofeedback, which have been successfully used, especially in managing disruptive and unstable patients.
- E. **Quality of life (QOL).** It is essential for the medical staff and family to address the patient's perception of QOL. This is especially important when making decisions regarding the initiation or withdrawal of dialysis. Patients who rate their QOL higher and have an increased sense of well-being may be more likely to comply with their dialysis prescription. There are several different scales that have been used to assess QOL in ESKD patients, including the SF-36, Illness Effects Questionnaire, Karnofsky Scale, Satisfaction with Life Scale, and the KD-QOL, or Kidney Disease Quality-of-Life Scale. These scales primarily consist of subjective measures. Therapy with erythropoietin has improved QOL for dialysis patients. ESKD patients with successful renal transplants tend to rate their QOL higher than those with failed transplants or those treated with dialysis. There have been several recent clinical trials that evaluated the impact of intensification of dialysis prescriptions on patients' perceptions of quality of life. The Frequent Hemodialysis Network (FHN) evaluated the effect of intense dialysis six times weekly versus conventional three times weekly treatments on quality of life and depression scores. Although there were few changes in many subdomain measures of QOL, there were improvements in both the SF-36 and BDI scores in the six times weekly dialysis arm. Physicians should strongly consider the impact their medical decisions have on a patient's QOL, and discuss these issues in depth with patients and their families. In addition, patient satisfaction with care is an important aspect of QOL that should be evaluated.

Suggested Readings

- American Psychiatric Association. *Diagnostic and Statistical Manual of Mental Disorders* 5th ed. Arlington, VA: American Psychiatric Publishing; 2013.
- Atalay H, et al: Sertraline treatment is associated with an improvement in depression and health-related quality of life in chronic peritoneal dialysis patients. *Int Urol Nephrol*. 2010;42:527–536.
- Blumenfeld M, et al. Fluoxetine in depressed patients on dialysis. *Int J Psychiatry Med*. 1997;27:71–78.
- Castaneda C, et al. Resistance training to reduce the malnutrition-inflammation complex syndrome of

chronic kidney disease. *Am J Kidney Dis.* 2004;43:607–616.

Chertow GM, et al. In-center hemodialysis six times per week versus three times per week. *N Engl J Med.* 2010;363:2287–2300.

Cohen SD, et al. Screening, diagnosis, and treatment of depression in patients with end-stage renal disease. *Clin J Am Soc Nephrol.* 2007;2:1332–1342.

Cukor D, et al. Psychosocial aspects of chronic disease: ESRD as a paradigmatic illness. *J Am Soc Nephrol.* 2007;18:3042–3055.

Cukor D, et al. Anxiety disorders in adults treated by hemodialysis: a single-center study. *Am J Kidney Dis.* 2008;52:128–136.

Cukor D, et al. Psychosocial intervention improves depression, quality of life, and fluid adherence in hemodialysis. *J Am Soc Nephrol.* 2014;25:196–206.

Daneker B, et al. Depression and marital dissatisfaction in patients with end-stage renal disease and in their spouses. *Am J Kidney Dis.* 2001;38:839–846.

Dheenan S, et al. Effect of sertraline hydrochloride on dialysis hypotension. *Am J Kidney Dis.* 1998;31:624–630.

Dogan E, et al. Relation between depression, some laboratory parameters, and quality-of-life in hemodialysis patients. *Ren Fail.* 2005;27:695–699.

Finkelstein FO, et al. Depression in chronic dialysis patients: assessment and treatment. *Nephrol Dial Transplant.* 2000;15:1911–1913.

Friend R, et al. Group participation and survival among patients with end-stage renal disease. *Am J Public Health.* 1986;76:670–672.

Gee CB, et al. Couples coping in response to kidney disease: a developmental perspective. *Semin Dial.* 2005;18:103–108.

Hedayati SS, et al. A practical approach to the treatment of depression in patients with chronic kidney disease and end-stage renal disease. *Kidney Int.* 2012;81:247–255.

Holley JL. Palliative care in end-stage renal disease: focus on advance care planning, hospice referral, and bereavement [Review]. *Semin Dial.* 2005;18:154–156.

Kimmel PL. Just whose quality-of-life is it anyway? Controversies and consistencies in measurements of quality-of-life. *Kidney Int.* 2000;57(suppl 74):113–120.

Kimmel PL, et al. Marital conflict, gender and survival in urban hemodialysis patients. *J Am Soc Nephrol.* 2000;11:1518–1525.

Kimmel PL, et al. Multiple measurements of depression predict mortality in a longitudinal study of chronic hemodialysis patients. *Kidney Int.* 2000;57:2093–2098.

Kimmel PL, et al. Depression in end-stage renal disease patients treated with hemodialysis: tools, correlates, outcomes, and needs. *Semin Dial.* 2005;18:73–79.

King K, et al. The frequency and significance of the “difficult” patient: the nephrology community’s perceptions. *Adv Chronic Kidney Dis.* 2004;11:234–239.

Kolewaski CD, et al. Quality-of-life and exercise rehabilitation in end stage renal disease. *CANNT J.* 2005;15:22–29.

Kouidi E, et al. Exercise renal rehabilitation program: psychosocial effects. *Nephron.* 1997;77:152–158.

Kurella M, et al. Chronic kidney disease and cognitive impairment in the elderly: the Health, Aging and Body Composition Study. *J Am Soc Nephrol.* 2005;16:2127–2133.

- Kurella M, et al. Suicide in the end-stage renal disease program. *J Am Soc Nephrol*. 2005;16:774–781.
- Lopes AA, et al. Depression as a predictor of mortality and hospitalization among hemodialysis patients in the United States and Europe. *Kidney Int*. 2002;62:199–207.
- Moss AH, et al. Palliative care [Review]. *Am J Kidney Dis*. 2004;43:172–173.
- Painter P. Physical functioning in end-stage renal disease patients: update 2005 [Review]. *Hemodial Int*. 2005;9:218–235.
- Patel SS, et al. Psychosocial variables, quality of life and religious beliefs in end-stage renal disease patients treated with hemodialysis. *Am J Kidney Dis*. 2002;40:1013–1022.
- Patel S, et al. The impact of social support on end-stage renal disease. *Semin Dial*. 2005;18:89–93.
- Renal Physicians Association. *Shared decision making (guideline regarding withdrawal from dialysis and palliative care)*. Available at <http://www.renalmd.org/>. Accessed September 12, 2006.
- Shidler NR, et al. Quality-of-life and psychosocial relationships in patients with chronic renal insufficiency. *Am J Kidney Dis*. 1998;32:557–566.
- Snow V, et al. Pharmacologic treatment of acute major depression and dysthymia. American College of Physicians-American Society of Internal Medicine. *Ann Intern Med*. 2000;132:738–742.
- Tawney K. Developing a dialysis rehabilitation program. *Nephrol Nurs J*. 2000;27: 524–539.
- Turk S, et al. Treatment with antidepressive drugs improved quality-of-life in chronic hemodialysis patients. *Clin Nephrol*. 2006;65:113–118.
- Unruh ML, et al. Health-related quality-of-life in nephrology research and clinical practice. *Semin Dial*. 2005;18:82–90.
- Watnick S, et al. The prevalence and treatment of depression among patients starting dialysis. *Am J Kidney Dis*. 2003;41:105–110.
- Wilson B, et al. Screening for depression in chronic hemodialysis patients: comparison of the Beck Depression Inventory, primary nurse, and nephrology team. *Hemodial Int*. 2006;10:35–41.
- Wu AW, et al. Changes in quality-of-life during hemodialysis and peritoneal dialysis treatment: generic and disease specific measures. *J Am Soc Nephrol*. 2004;15:743–753.
- Wuerth D, et al. Chronic peritoneal dialysis patients diagnosed with clinical depression: results of pharmacologic therapy. *Semin Dial*. 2003;16:424–427.
- Wuerth D, et al. The identification and treatment of depression in patients maintained on dialysis. *Semin Dial*. 2005;18:142–146.

- I. **CAUSES OF PROTEIN ENERGY WASTING (PEW) IN CKD PATIENTS.** Metabolic and nutritional derangements are common in patients with chronic kidney disease (CKD), especially in patients on maintenance dialysis therapy (Ikizler, 2013). These derangements are called protein energy wasting (PEW) of CKD. Patients with this syndrome have increased rates of hospitalization and mortality (Kalantar-Zadeh, 2004). There are multiple etiologies of PEW (Table 31.1), including decreased nutrient intake; metabolic derangements such as metabolic acidosis, dialysis-associated catabolism, uremic toxins; and comorbid medical conditions such as diabetes mellitus and cardiovascular disease (Carrero, 2013). PEW affects approximately one-third of hemodialysis and peritoneal dialysis patients (Pupim, 2006). The sequelae of PEW in kidney disease are numerous and include malaise, fatigue, poor rehabilitation, impaired wound healing, increased susceptibility to infection, increased cardiovascular disease risk, and increased rates of hospitalization and mortality. In most instances, serum levels of inflammatory markers are increased, and numerous causes of chronic inflammation may be present (Kaysen, 2001). Proinflammatory cytokines can cause anorexia with suppression of nutrient intake (Kaizu, 2003). Chronic inflammation also is associated with cytokine-mediated hypermetabolism and resistance to anabolic actions of insulin leading to increased net protein catabolism (Siew, 2010). Disruption of the growth hormone (GH) and insulin-like growth factor-1 (IGF-1) axis leads to decreased protein synthesis. Increased leptin concentrations may worsen anorexia due to central effects.
- A. **Obesity.** Concern has always focused on wasting in CKD patients, because the death rate increases steeply with evidence of skeletal muscle loss, weight that is below peer weight, or body mass index. There is, however, an increasing incidence of obesity among patients initiating maintenance dialysis therapy (Kramer, 2006). Although obesity has traditionally been defined in terms of body mass index, some dialysis patients who are normal or overweight by BMI have been found to be obese as defined by percent body fat (Gracia-Iguacel, 2013). Studies of the effect of obesity on survival in dialysis patients are difficult to interpret because of the observational nature of the studies, differences in analysis techniques and definitions of obesity, and confounding (Stenvinkel, 2013).

Decreased nutritional intake

Overzealous dietary restrictions

Delayed gastric emptying and diarrhea

Intercurrent illnesses and hospitalizations

Decrease in food intake on hemodialysis days

Medications causing dyspepsia (phosphate binders, iron preparations)

Suppression of oral intake by peritoneal dialysate glucose load

Inadequate dialysis

Monetary restrictions

Inability to prepare or acquire food due to physical limitations

Poor dentition or severe gum disease

Neurologic disorders that impair eating/swallowing

Depression

Altered sense of taste

Increased losses

Gastrointestinal blood loss (100 mL blood = 14–17 g protein)

Intradialytic nitrogen losses (hemodialysis, 6–8 g amino acid per procedure; peritoneal dialysis, 8–10 g protein per day)

Severe proteinuria (>8–10 g/d)

Increase in protein catabolism

Intercurrent illnesses and hospitalizations

Other medical comorbidities, including diabetes mellitus, cardiovascular disease, infection

Metabolic acidosis (promotes protein catabolism)

Catabolism associated with hemodialysis (due to activation of proinflammatory cytokines)

Dysfunction of the growth hormone–insulin growth factor endocrine axis

Insulin resistance

Catabolic effects of other hormones (parathyroid hormone, cortisol, glucagon)

II. NUTRITIONAL ASSESSMENT

- A. Patient interview and physical examination.** Symptoms of nausea, vomiting, and anorexia, as well as recent changes in body weight, should be carefully evaluated to ascertain cause. Nonuremic causes of changes in weight and/or food intake must be kept in mind, including severe congestive heart failure, diabetes, various gastrointestinal diseases, and depression. Phosphate binders or oral iron preparations can cause dyspepsia and other gastrointestinal symptoms.
- B. Assessment of food intake.** Patient recall of food intake should be determined on both dialysis and nondialysis days, performed biannually (Kopple, 2001); intake on dialysis days typically is about 20% lower (Burrowes, 2003). Food frequency questionnaires may also provide useful information (Kalantar-Zadeh, 2002).
- C. Nutritional screening tools:** A variety of screening tools are available, such as the Malnutrition

Universal Screening Tool (MUST), Mini Nutritional Assessment (MNA), and others. All these tools require a brief patient interview. Questions that are common to all screening tools include information about body weight changes within a given time frame, amount of oral intake, or lack of appetite. Because of its simplicity and reliability, the Malnutrition Screening Tool (MST), which is simpler to apply than the more comprehensive MUST, is suggested as the first option. The MST includes two questions about weight loss and one question about appetite. When scores for answers to these questions are added together and the result is greater than 2, the patient is at risk for malnutrition/PEW, and a nutritional assessment is recommended.

C. Nutritional assessment tools

1. Body composition

- a. **Body weight and body mass index.** One should compare ideal or median standard weight (see Appendix B) with actual body weight. Comparison with prior values is important as both body weight and lean body mass decrease over time in hemodialysis patients (Di Filippo, 2006; Rocco, 2004). Although BMI is easy to calculate and is used in many nutritional guidelines, it should be emphasized that this metric is a poor estimate of fat mass and its distribution within the body, especially in patients with CKD.
- b. **Anthropometry.** The waist–hip ratio (WHR) and skinfold thickness are superior to BMI for the correct classification of obesity in CKD in cross-sectional studies. Skinfold thickness measured at the biceps or triceps provides an estimate of body fat, whereas midarm circumference can be used to estimate muscle mass. These measures can be compared with reference ranges established in well-nourished dialysis patients (Chumlea, 2003). Patients with values below the 25th percentile for either middle upper arm circumference or triceps skinfold thickness are likely to be malnourished.
- c. **Bioimpedance.** Bioimpedance analysis is based on the measurement of resistance and reactance when a constant alternating electrical current is applied to a patient. Empirical equations are used to predict total-body water from resistance and total-body mass from the ratio of resistance to reactance or from its geometrical derivative, the phase angle. Phase angle correlates strongly with anthropometric measures of nutritional status and with serum albumin levels. For reproducibility, bioimpedance measurements should be performed within 120 minutes of the end of a dialysis treatment (Di Iorio, 2004). Low phase angle measurements are associated with an increased risk of mortality (Mushnick, 2003). An international study using bioimpedance spectroscopy has noted an impairment in the lean tissue index in all dialysis patients, with better preservation in peritoneal dialysis patients versus hemodialysis patients (van Biesen, 2013).
- d. **Dual energy x-ray absorptiometry (DEXA).** This test was developed to measure bone density, but was later adapted to quantify soft tissue composition, including fat and fat-free mass. A DEXA scan takes only 6–15 minutes, involves minimal radiation exposure, and hence can be used serially to follow changes over time. At present, DEXA is used mostly for research purposes; it is more costly, and there are no

data relating DEXA results to outcome in patients with advanced kidney disease. DEXA findings must be evaluated with hydration status in mind as well.

2. **Composite indices.** Subjective global assessment (SGA) is a clinical method for evaluating nutritional status that includes history, symptoms, and physical parameters. The history component focuses on five areas: (a) percentage of body weight lost in the previous 6 months; (b) dietary nutrient intake; (c) the presence of anorexia, nausea, vomiting, diarrhea, or abdominal pain; (d) functional capacity; and (e) metabolic demands in view of underlying disease state. Physical parameters focus on assessment of subcutaneous fat; muscle wasting in the temporal area, deltoids, and quadriceps; the presence of ankle or sacral edema; and the presence of ascites. The SGA has a good reproducibility and correlates strongly with outcomes in end stage kidney disease (ESKD) patients (Duerksen, 2000). Other scoring systems that have been proposed include the modified SGA (Churchill, 1996), the Dialysis Malnutrition Score, and the Malnutrition Inflammation Score (Kalantar-Zadeh, 2001), all of which use a combination of objective and subjective factors. The Geriatric Nutritional Risk Index (GNRI) consists of only three objective parameters—body weight, height, and serum albumin level; the score is predictive of mortality (Kobayashi, 2010).

E. Laboratory tests

1. **Serum albumin.** Low levels are a strong predictor of mortality, and hospitalization risk rises dramatically and logarithmically as levels decline below 4.0 g/dL (40 g/L). The assay method used can change results by as much as 20%. Serum albumin levels correlate modestly with other nutritional measures, and hypoalbuminemia may be due to a low nutrient intake, protein losses, increased catabolism or some combination of these mechanisms. Additional assessment including, but not limited to, physical exam, dietary recalls and measurement of acute phase reactants (e.g., plasma C-reactive protein level) is necessary for appropriate management of the patient.
2. **Predialysis serum urea nitrogen (SUN).** The predialysis SUN level reflects the balance between urea generation and removal. Thus, a low SUN level could occur in a very well-dialyzed patient with good protein intake, or in an inadequately dialyzed patient with poor protein intake. Also, a low SUN may reflect substantial residual kidney function or a markedly anabolic state (such as during rapid recovery from an intercurrent illness). Therefore, it is difficult to infer the level of protein intake from the SUN directly.
3. **Urea nitrogen appearance (g).** This measurement can be used to estimate protein intake. This is because, in the absence of marked catabolism or anabolism, the urea nitrogen appearance rate reflects protein intake. In catabolic or anabolic patients, protein intake will be over- or underestimated, respectively. As discussed in Chapter 3, in hemodialysis patients, the g can be computed using a pre- and postdialysis SUN. In patients with AKI, g can be estimated by measuring SUN at two time points, usually 24 hours apart, after making an estimate of total body water. Another method used in computing g for both hemodialysis and peritoneal dialysis patients is to collect aliquots of the spent dialysate as well as urine, and to measure the amount of urea nitrogen in each.
4. **Protein equivalent of total nitrogen appearance (PNA).** Several formulas are available for the calculation of PNA from g, given that, on average, the percentage of

nitrogen from protein that winds up as urea is known. Dialysis modeling programs usually normalize the PNA to the “kinetic” body weight; the latter is estimated as urea distribution volume divided by 0.58. The kinetic weight (which usually is an internal number and is not reported) is usually, but not always, close to the actual body weight. Dividing PNA by the kinetic weight gives a “normalized” PNA, or nPNA in units of g/kg per day.

5. **Clinical utility of the nPNA.** The utility of the PNA in terms of predicting outcomes has been questioned. In the HEMO trial, as well as in observational data sets, once serum albumin and creatinine were controlled for, the PNA had little, if any, additional predictive power in terms of outcome. In the HEMO trial, PNA was a very poor predictor of dietary protein intake. It was assumed that the dietary recall method used was not sufficiently sensitive to show a relationship, but alternative explanations are possible as well.
6. **Other laboratory measures.** Serum transferrin is low in almost all dialysis patients and is influenced by changes in iron stores, presence of inflammation, and changes in volume status; it is not a good indicator of nutritional status. **Serum prealbumin** levels may be elevated because of interaction of prealbumin with retinol-binding protein and decreased renal clearance. **C-reactive protein (CRP)** is an acute phase reactant that correlates negatively with albumin and other visceral protein concentrations. When serum levels of albumin or prealbumin are low, it is appropriate to check CRP levels to help uncover potential covert inflammation. CRP levels are highly variable in ESKD patients, reducing their practical utility, but serial CRP measurements may provide valuable information.

III. **DIETARY REQUIREMENTS.** The recommended average levels of nutritional intake are listed in Table 31.2, and include recommendations that are generally consistent with the National Kidney Foundation’s (NKF) Kidney Disease Outcome Quality Initiative (KDOQI) 2001 guidelines on nutrition (NKF, 2001) and the European best practice guidelines for nutrition (Dombros, 2005).

TABLE
31.2

Daily Dietary Recommendations For Dialysis Patients^a

Nutrient or Substance	Hemodialysis	Peritoneal Dialysis
Protein (g/kg)	>1.2	>1.2; >1.5 with peritonitis
Calories (sedentary, kcal/kg)	30–35 ^b	30–35 ^{b, c}
Protein (%)		15–25
Carbohydrate (%)	50–60 ^d	50–60 ^{c, d}
Fat (%)		25–35
Cholesterol		<200 mg (0.52 mmol)
Saturated fat (%)		<7
Crude fiber (g)		20–30
Sodium		80–100 mmol ^e

Potassium	< 1 mmol/kg if elevated	Usually not an issue
Calcium	2.0 g (50 mmol) ^f	
Phosphorus	0.8–1.0 g (26–32 mmol) ^g	
Magnesium	0.2–0.3 g (8–12 mmol)	
Iron	See Chapter 34	
Vitamin A	None	
β-carotene	None	
Retinol	None	
Thiamine (mg)	1.5	
Riboflavin (mg)	1.7	
Vitamin B6 (mg)	10	
Vitamin B12 (mg)	0.006	
Niacin (mg)	20	
Folic acid (mg)	>1.0	
Pantothenic acid (mg)	10	
Biotin (mg)	0.3	
Vitamin C (mg)	60–100	
Vitamin E	None	
Vitamin D	See Chapter 36	
Vitamin K	See text	

^aAll intakes calculated on the basis of normalized body weight (i.e., the average body weight of normal persons of the same age, height, and sex as the patient).

^b35 kcal/kg body weight per day if <60 years of age; 30–35 kcal/body weight per day if >60 years of age.

^cIncludes glucose absorbed from dialysis solutions.

^dCarbohydrate intake should be decreased in patients with hypertriglyceridemia.

^eLower sodium intakes, in the range of 1.0–1.5 g (43–65 mmol), may result in better control of blood pressure in peritoneal dialysis patients and a lower dialysis solution glucose load, and are recommended if this can be done while maintaining energy intake.

^fThe total dose of elemental calcium provided by the calcium-based phosphate binders should not exceed 1,500 mg (37 mmol) per day, and the total intake of elemental calcium (including dietary calcium) should not exceed 2,000 mg (50 mmol) per day.

^gFor patients with serum phosphorus level >5.5 mg/dL (1.8 mmol/L); use phosphate binders if elevated.

- A. **Need for individualization.** A “renal” diet has numerous restrictions, and so adherence to such a diet can be difficult and stressful. Prescribed diets should be individualized to help accommodate each patient’s unique circumstances in terms of palatability, cost, comorbid medical conditions, and cultural eating habits. Specific nutritional issues in the diabetic dialysis patient are discussed in Chapter 32. Too many restrictions should be avoided as they may lead to poor intake. The nutritional recommendations need to be reinforced by all members of the health care team. Compliance should be assessed on a regular basis, even monthly at the initiation of dialysis or for those with a previous history of noncompliance.

B. **Peer rather than actual body weight.** One problem with dietary intake recommendations for dialysis patients, who often have PEW, is the choice of weight to use in the denominator. For example, if a patient has lost body mass such that his or her weight is now 50 kg versus a premorbid weight of 90 kg, ingestion of an “adequate” amount of protein or calories based on actual weight may maintain the patient at that lower body weight, but may not be optimal for regaining lost weight, assuming that this is desired. Protein and caloric recommendations should be based on the median standard (or “peer”) body weight (see Tables B.1 and B.2 in Appendix B) for healthy subjects of the same sex, height, age, and body frame size as the patient. On the other hand, in obese patients, adjusted body weight should be used ($\text{Adjusted BW} = \text{Peer Body Weight} + 0.25 \times (\text{actual Body Weight} - \text{Peer Body Weight})$).

Example: A severely malnourished 35-year-old male hemodialysis patient weighs 60 kg. Using the Tables in Appendix B for peer weight, we find that the peer weight for this medium-frame patient (were he healthy) given a height of 183 cm (72 in.) would be about 84 kg. Our urea kinetic modeling program had reported that his nPNA was 1.2 g/kg per day. As discussed above, this nPNA is based on the patient’s “kinetic” weight. Is this patient ingesting an adequate amount of protein?

We can recover the value for modeled V from the program and divide this by 0.58 to find the “kinetic” weight that was used by the program. Assume that this turns out to be 60 kg. Then $1.2 \text{ g/kg per day} = 1.2 \times 60 = 72 \text{ g per day}$ for his PNA, which means that estimated protein intake is also 72 g per day. To compute PNA normalized to this patient’s peer weight, we divide 72 by 84 kg. Now his PNA/peer weight is only $72/84 = 0.86 \text{ g/kg per day}$, which may be suboptimal.

C. **Adequacy of dialysis.** The delivery of a dialysis dose that is less than adequate can adversely affect appetite, nutrient intake, and measures of nutrition. Provision of adequate dialysis corrects subtle uremia and thus mitigates uremia-associated anorexia, and may improve hypercatabolism as well. Having said this, in the HEMO study, there was no improvement in either protein or energy intake in patients randomized to high-dose (single-pool $Kt/V \sim 1.65$) compared with patients randomized to standard-dose (single-pool $Kt/V \sim 1.25$) dialysis. Weight declined similarly in both groups of patients, although the decreases in some anthropometric parameters were somewhat less for patients assigned to the higher dialysis dose (Rocco, 2004). Assignment to the high-flux group had little measurable nutritional advantage. Despite anecdotal reports of marked nutritional improvement on changing hemodialysis patients from a three per week to more frequent schedule, the two randomized Frequent Hemodialysis Network trials failed to find improvement in either serum albumin or lean body mass in patients assigned to more frequent short daily or long nocturnal therapy (Kaysen, 2012). Claims have also been made of nutritional improvement in patients receiving intermittent hemofiltration or hemodiafiltration, but the supportive evidence is also relatively weak.

D. **Protein.** KDOQI guidelines recommend that both hemodialysis and peritoneal dialysis patients should ingest 1.2 g of protein/kg (using peer body weight) per day. At least 50% of the protein ingested should be of high biologic value. This level of protein intake is often difficult to achieve in practice, however, and 30%–50% of hemodialysis patients report

intakes of <1.0 g of protein/kg per day (Rocco, 2004).

- E. **Energy.** KDOQI guidelines recommend that all dialysis patients younger than 61 years ingest 35 kcal/kg per day. For patients older than 60 years, the recommended intake is 30–35 kcal/kg per day, with the lower value used for sedentary patients. Note that this level of intake includes any calories provided from the dialysis procedure. Higher levels of caloric intake may be required for patients who perform strenuous labor, for patients who are well below their desired weight, and for patients who are hospitalized, have peritonitis, or have other causes of catabolic stress. This recommended level of caloric intake is difficult to achieve in practice; as an example, in the HEMO study, intake based on dietary recall averaged 23–27 kcal/kg. The data correlate with an observed mean resting energy expenditure of 24.6 kcal/kg per day in Japanese hemodialysis patients (Kogirima, 2006). This may be related to the usual underreporting observed in dietary recalls. The KDOQI recommended levels of dietary protein and energy intake have been achieved in some patients receiving more frequent hemodialysis (Rocco, 2013).

In peritoneal dialysis patients, a substantial amount of glucose absorbed from the dialysate contributes to total energy intake (Table 31.3), which occurs daily; the amount depends on the percent dextrose used for each dwell, the length of each exchange, the volume of each dwell, the number of exchanges, and peritoneal membrane transport properties.

TABLE

31.3

Estimated Kilocalories of Glucose Absorbed as Instilled Volume Varies in CAPD and APD Patients

Instilled Volume	%D Daytime	%D Overnight	kcal Absorbed
CAPD			
4 × 2.0 L	1.5% D	2.5% D	332
4 × 2.5 L	1.5% D	7.5% Icodextrin	187
4 × 2.5 L	1.5% D	2.5% D	386
4 × 3.0 L	1.5% D	2.5% D	432
APD (day dwell) ^a			
3 × 2.0 & 2.0	2.5% D	1.5% D	299
3 × 2.5 & 2.5	2.5% D	1.5% D	350
3 × 3.0 & 3.0	2.5% D	1.5% D	396
3 × 2.5 & 2.5 + 2.5	Both 1.5% D	1.5% D	342
3 × 2.5 & Ico	7.5% Icodextrin	1.5% D	144

D, % dextrose of instilled solution; APD, automated peritoneal dialysis.

^aAPD using 9 hours overnight and three exchanges per night and a last-bag-fill for APD regimens 1, 2, 3, and 5. APD regimen 4 includes a last-bag-fill and midday exchange.

Adapted from Burkart J. Metabolic consequences of peritoneal dialysis. *Semin Dial.* 2004 17: 498–504. These estimates do not take into account glucose losses during icodextrin dwells or kcal gained from the metabolism of polyglucose.

1. **Percent carbohydrates.** Table 31.2 reflects the conventional wisdom that 50%–60% of dietary intake (including glucose absorbed from dialysate) should be carbohydrates. This would represent 1,000 kcal, or 250 g of carbohydrates, for a 2,000-kcal diet. Given that 300–400 kcal of glucose is normally absorbed with most peritoneal dialysis

regimens, in peritoneal dialysis patients the percent carbohydrates ingested as food needs to be reduced by a similar amount. Hypertriglyceridemia and impaired glucose tolerance are common in peritoneal dialysis patients and are not rare in those being treated with hemodialysis. For such patients, the percent carbohydrates may need to be further reduced, with the caloric deficit being made up primarily by increased intake of both protein and monounsaturated fats (Arora, 2005).

- F. **Lipids.** The classic therapeutic goal for hemodialysis patients has been to achieve a low-density lipoprotein (LDL) cholesterol of <100 mg/dL (2.6 mmol/L) and a fasting triglyceride level of <500 mg/dL (5.7 mmol/L). Therapeutic lifestyle changes include diet, weight reduction, increased physical activity, abstinence from alcohol, and treatment of hyperglycemia, if present. However, in dialysis patients, low LDL cholesterol levels are not associated with improved cardiovascular health or survival. Thus, these recommendations are not evidence-based but rather are ported from patients with normal kidney function. With regard to diet composition, the usual recommendation has been a diet containing <7% saturated fat, with polyunsaturated fat <10% of total calories and monounsaturated fat <20% of total calories, and with total fat at 25%–35% of total calories. However, the conventional wisdom regarding the adverse cardiovascular effects of saturated fat is currently the subject of a large amount of controversy (Chowdhury, 2014). Carbohydrates should not exceed 50%–60% of total calories in hemodialysis patients, and dietary carbohydrate intake should likely be even less in peritoneal dialysis patients. In all dialysis patients, 20–30 g of fiber per day should be consumed to help reduce dyslipidemia and to reduce gastrointestinal transit time, as high-fiber diets have in general been associated with lower cardiovascular mortality. Many uremic toxins such as indoxyl sulfate and p-cresol sulfate may be generated by bacteria in the gut, and reducing gastrointestinal transit time may limit the time during which gut bacteria can generate these toxins. Lipid management is discussed in more detail in Chapter 38.
- G. **Sodium and water.** Most excess fluid intake is driven by ingestion of excess sodium, and dietary counseling needs to educate patients and their families about the importance of limiting sodium. In some patients, there are substantial non-salt-driven causes of fluid ingestion as well, and these should be sought and corrected. Regulatory bodies in the past suggested that healthy (non-CKD) persons limit dietary sodium intake to 2.3 g (100 mmol) per day, and for older persons, African Americans, or patients with kidney disease, a restriction to 1.5 g (65 mmol) per day, (Institute of Medicine, 2004); however, the extent to which sodium reduction leads to cardiovascular benefits is currently a source of controversy (Institute of Medicine, 2013). In peritoneal dialysis, although one can remove sodium-stimulated fluid ingestion using higher glucose dwells, this comes at the cost of glucose loading, with potential adverse effects on the peritoneal membrane as well as on lipids and triglyceride levels, so a lower sodium intake is desirable. In ESKD patients who are anuric, fluid intake generally should be limited to about 1.0–1.5 L per day. Additional fluid can be consumed in patients with residual renal function, with the amount based on the daily urine volume.
- H. **Potassium.** Mild potassium restriction (4 g or 100 mmol per day) is usually all that is needed in patients with a moderate degree of residual renal function. Hyperkalemia

sometimes becomes an issue in the presence of acidemia or hypoaldosteronism, or with the administration of nonsteroidal anti-inflammatory drugs (NSAIDs), potassium-sparing diuretics, angiotensin-converting enzyme inhibitors, angiotensin blockers, aldosterone receptor antagonists, or β -receptor blockers.

Hyperkalemia in anuric peritoneal dialysis patients is unusual because the dialysate contains no potassium. Peritoneal dialysis patients typically require only modest potassium restriction (4 g or 100 mmol per day) or no restriction at all. In hemodialysis patients with limited residual renal function, a lower intake of potassium (2 g or 50 mmol per day) is often required to prevent predialysis hyperkalemia. An important issue that needs attention is to limit exposure to very low potassium (0 K or 1 K) hemodialysis solutions, as the latter have been associated with arrhythmias and an increased risk of sudden death.

I. **Calcium and phosphorus.** The dietary intake of calcium and phosphorus and management of hyperphosphatemia are discussed in Chapter 36. An important issue that needs to be kept in mind is that dietary protein recommendations should consider not only the phosphorus content from protein sources but also the phosphorus content in additives and preservatives in processed foods, which can be substantial (Kalantar-Zadeh, 2010)

J. **Vitamins**

1. **Water-soluble vitamins.** Dialysis patients may develop deficiencies of water-soluble vitamins unless supplements are given. Vitamin deficiencies are caused by poor intake, interference with absorption by drugs or uremia, altered metabolism, and losses to the dialysate. All dialysis patients should receive supplementary folic acid and B vitamins in the doses listed in Table 31.2. B-vitamin replacement may need to be more intensive in patients undergoing high-flux dialysis owing to increased losses (Kasama, 1996). High levels of folate supplementation, however, do not result in a significant decrease in homocysteine levels (Ghandour, 2002). Ascorbic acid supplementation should be limited to 60–100 mg per day as higher doses can result in the accumulation of its metabolite, oxalate. The use of injectable vitamin B12 in patients with lower-range serum cobalamin levels to reduce erythropoietin stimulating agent requirements is discussed in Chapter 34.

2. **Fat-soluble vitamins.** Fat-soluble vitamins cannot be removed by either hemodialysis or peritoneal dialysis. Multivitamin supplementation in maintenance dialysis patients should not include fat-soluble vitamins. The dosing of vitamin D is discussed in Chapter 36. Vitamin E has been promoted as an antioxidant in maintenance dialysis patients, although supplemental therapy has not led to any changes in markers of inflammation or oxidative stress (Himmelfarb, 2014) despite encouraging earlier studies. One should carefully check any vitamin given to ESKD patients to make sure that it does not contain vitamin A. High levels of vitamin A can result in multiple, serious adverse effects in nonuremic individuals. Hypervitaminosis A in dialysis patients can also cause anemia and abnormalities of lipid and calcium metabolism. Recently there has been a focus on low vitamin K levels and impaired vitamin K recycling in ESKD patients as a potential cause for accelerated vascular calcification. Vitamin K comes in 2 available forms, phylloquinone (K1), found in green leafy vegetables, and menaquinone (K2), found in fermented dairy products. Phylloquinone

can be converted to menaquinone. Dietary menaquinone intake correlates inversely with levels of an inactivated form of calcification inhibitor, dephosphorylated, uncarboxylated matrix Gla protein (dp-uc-MGP; Calluwe, 2014). Currently there are two randomized trials in progress (Calluwe, 2014; Krueger, 2014) that will give either menaquinone (K2) or phylloquinone (K1) supplements, respectively, to dialysis patients, to see if this retards progression of vascular calcification.

IV. NUTRIENT REQUIREMENTS IN HOSPITALIZED PATIENTS WITH KIDNEY DISEASE

A. **Energy requirements in hospitalized dialysis patients.** In general, most patients with acute kidney injury (AKI) requiring dialysis have energy needs between 30 and 40 kcal/kg. Higher levels of caloric intake have not been shown to be beneficial from a nutritional standpoint, worsen net nitrogen balance, and can cause hypercapnia, especially if patients have impaired pulmonary function. A simple method is to assume a baseline requirement of 30 or 35 kcal/kg per day, and then multiply by one or more adjustment factors, which range from 1.1 to 1.7, and are used when hypermetabolism is likely to be present (Table 31.4). Apart from these adjustment factors, energy expenditure in acutely ill patients with AKI has not been shown to be higher than in acutely ill patients with normal kidney function (Soop, 1989).

TABLE

31.4

Adjustment factors for determination of energy requirements

Clinical Condition	Adjustment Factor
Mechanical ventilation	
Without sepsis	1.10–1.20
With sepsis	1.25–1.35
Peritonitis	1.15
Infections	
Mild	1.00–1.10
Moderate	1.10–1.20
Sepsis	1.20–1.30
Soft tissue trauma	1.10
Bone fractures	1.15
Burns (% of body surface area)	
0%–20%	1.15
20%–40%	1.50
40%–100%	1.70

Recommendations adapted from Blackburn GL, et al. Nutritional and metabolic assessment of the hospitalized patient. *J Parenter Enteral Nutr.* 1977;1:11–22; Bouffard Y, et al. Energy expenditure in the acute renal failure patient mechanically ventilated. *Intens Care Med.* 1987;13:401–404; Schneeweiss B, et al. Energy metabolism in acute and chronic renal failure. *Am J Clin Nutr.* 1990;52:596–601; Soop M, et al. Energy expenditure in postoperative multiple organ failure with acute renal failure. *Clin Nephrol.* 1989;31:139–145.

- B. **Protein requirements.** In critical illness, amino acids are infused to help prevent protein breakdown, not to provide an additional source of calories; hence, they are not counted as part of the daily energy intake. The amino acid intake for patients with AKI or CKD undergoing either maintenance dialysis or one of the continuous renal replacement therapies during a hospitalization should be in the range of 1.1–2.0 g/kg per day. There appears to be no benefit in using higher levels of protein supplementation, even in the face of very high nitrogen losses. When higher levels are given, there does not appear to be any additional improvement in nitrogen balance, and there is increased formation of urea and other nitrogenous waste products.
- C. **Lipid requirements.** Energy requirements cannot usually be achieved by the administration of glucose infusions alone. The daily amount of glucose administered should not exceed 5 g/kg body weight, as supplementation above this level results in incomplete oxidation of glucose and conversion of glucose to fat. The balance of energy requirements is provided by lipids. Lipids have a high specific energy content as well as a low osmolality. The daily provision of 1.0 g/kg body weight or less usually prevents the development of an essential fatty acid deficiency while decreasing the risk of hypertriglyceridemia.

V. TREATMENT

- A. **General comments.** Reversible causes of PEW of CKD should be diligently pursued and corrected (see Fig. 31.1 for a treatment algorithm developed by the International Society of Renal Nutrition and Metabolism). Inadequate dietary protein and energy intake is a major cause of PEW of CKD (Wang, 2003) and is often secondary to anorexia. Anorexia has many etiologies. The provision of adequate dialysis is a crucial first step in improving nutritional status; however, data on more frequent hemodialysis is mixed regarding the benefit of an increased dose of dialysis on nutritional parameters (Rocco, 2013). Other medical conditions, especially infection and inflammation, acidemia, intercurrent illness, and cardiovascular disease, should be identified and treated if possible. Metabolic acidosis promotes PEW by increasing muscle protein catabolism and by stimulating the oxidation of essential amino acids. Thus, a predialysis goal of 22–24 mmol/L in hemodialysis patients and >22 mmol/L in peritoneal dialysis patients is suggested for patients with PEW (Stein, 1997). Causes of inflammation, including the use of central venous catheters in hemodialysis, should be treated or eliminated if possible. Correction of GI disturbances, including diabetic gastroparesis, colitis, and pancreatic insufficiency, may also improve nutritional status. Other considerations include access to, and ability to prepare, food, ethnic and personal food preferences, and assessment for the need for or repair of dentures and/or bridges. Once reversible causes of poor nutritional status have been identified and corrected, intervention in the form of oral or parenteral supplements should be considered.

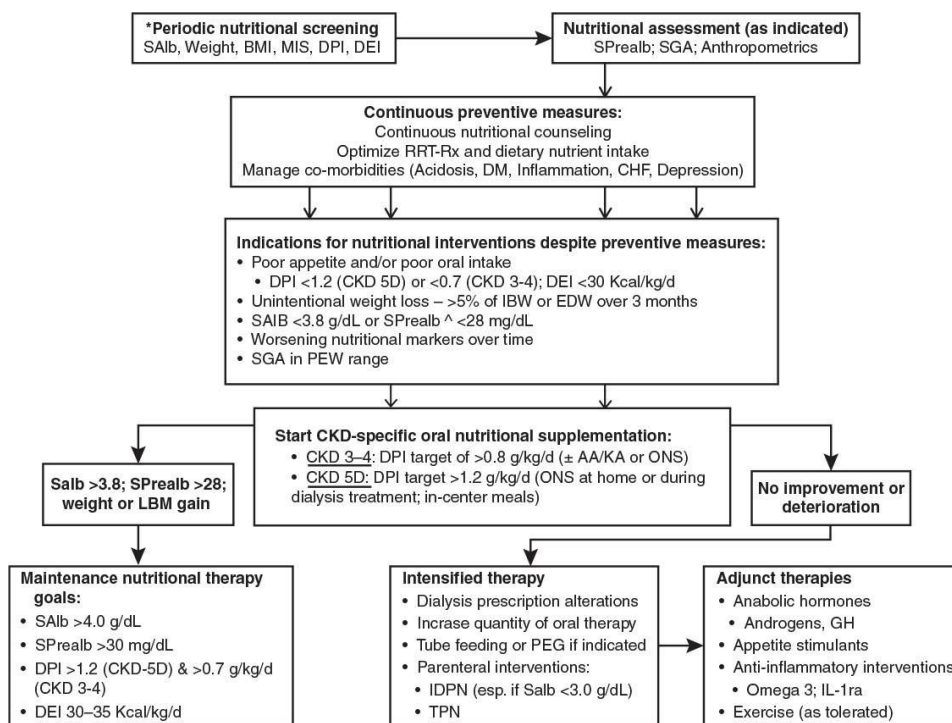

FIGURE 31.1 Algorithm for nutritional management and support in patients with chronic kidney disease. (Reproduced with permission from MacMillan Publishers Ltd: Ikizler TA, Cano NJ, Franch H, et al. Prevention and treatment of protein energy wasting in chronic kidney disease patients: a consensus statement by the International Society of Renal Nutrition and Metabolism. *Kidney Int.* 2013;84:1096–1107.) BMI, body mass index; CHF, congestive heart failure; DEI, dietary energy intake; DM, diabetes mellitus; DPI, dietary protein intake; EDW, end-dialysis weight; GH, growth hormone; IBW, ideal body weight; IDPN, intradialytic parenteral nutrition; MIS, malnutrition inflammation score; ONS, oral nutritional supplementation; PEW, protein energy wasting; RRT, renal replacement therapy; Salb, serum albumin; SPrealb, serum prealbumin; SGA, subjective global assessment; TPN, total parenteral nutrition.

B. When to initiate nutritional supplements. The International Society of Renal Nutrition and Metabolism has recently published recommendations for the nutritional management and support of patients with CKD (Ikizler, 2013). Once preventive and preliminary corrective approaches have failed, indications for prescription of nutritional supplements include the following (Fig 31.1):

1. Poor appetite and/or poor oral intake
2. Dietary protein intake (DPI) <1.2 g/kg per day, Dietary energy intake (DEI) <30 kcal/kg per day
3. Serum albumin level <3.8 g/dL or (if patient anuric) serum prealbumin level <28 mg/dL
4. Unintentional weight loss >5% of ideal body weight (IBW) or end-dialysis weight (EDW) over 3 months
5. Worsening nutritional markers over time
6. SGA in PEW range

The initial nutritional supplementation should be CKD specific with a target dietary protein intake of >1.2 g/kg per day for ESKD and >0.8 g/kg per day for

nondialysis CKD patients, a target dietary energy intake of 30–35 kcal/kg per day, a goal serum albumin level of 3.8 g/dL (38 g/L) initially, with a long-term goal of >4.0 g/dL (40 g/L).

Patients who do not show improvement with oral nutritional supplementation should have intensified therapy, which can include an increased quantity of oral nutritional supplementation, feeding via tube or percutaneous endoscopic gastrostomy or jejunostomy if indicated (Cano, 2009), and parenteral interventions. Intradialytic parenteral nutrition (IDPN) should be reserved for patients who cannot tolerate or do not respond to oral intake or use of a feeding tube. (Cano, 2006). Adjuvant therapies that can be considered include anabolic hormones, appetite stimulants, anti-inflammatory interventions, and exercise.

- C. **Oral supplements.** Oral amino acid supplementation, given either during hemodialysis (Kalantar-Zadah, 2013) or two to three times a day (preferably 1 hour after main meals), has been shown to improve whole-body protein metabolism in the short term and SGA, serum albumin, and serum prealbumin in the long term (Stratton, 2005) as well as patient outcomes (Weiner, 2014).

A number of different enteral formulas specifically formulated for maintenance dialysis patients are available. Other considerations in the choice of oral nutritional supplements include cost, palatability, and lactose tolerance.

D. **Intradialytic total parenteral nutrition (IDPN) in hemodialysis patients**

1. **Indications and benefits.** IDPN is indicated in the adequately dialyzed hemodialysis patient with PEW who is unable to ingest or absorb sufficient food via the gastrointestinal tract. IDPN promotes protein anabolism in the acute setting. There are conflicting reports of the benefits of IDPN; it appears that there is a correlation between the response to nutritional supplementation and the severity of PEW and the amount of nutrients received. (Cano, 2007).
2. **Composition, infusion, and complications.** The IDPN solution is usually composed of an 8.5% amino acid solution mixed with 250 mL of 50% dextrose. It is infused into the venous drip chamber for the entire duration of the hemodialysis procedure. Additional energy can be provided by also infusing a lipid emulsion; patients receiving lipids should be monitored closely for hypertriglyceridemia, changes in liver function tests, or compromise of the reticuloendothelial system. A typical composition of IDPN solution is outlined in Table 31.5.

Painful arm cramps can occur when a high-osmolality IDPN solution is infused too rapidly (the dialysis session may need to be lengthened). Hypoglycemia can occur when a rapid infusion of glucose-containing IDPN solution is suddenly discontinued. Patients should consume some carbohydrate within the last 30 minutes of the IDPN infusion to prevent hypoglycemia. Likewise, if patients dialyze against a glucose-free dialysate, the IDPN should not be discontinued until the conclusion of the hemodialysis procedure.

Component	Amount
50% dextrose (D-glucose)	125 g (250 mL)
8.5% crystalline amino acids (essential and nonessential)	42.5 g (500 mL)
20% lipids	50 g (250 mL)
Electrolytes:	Sodium, phosphate, potassium sulfate, chloride, and magnesium with amount per IDPN bag adjusted for serum electrolyte levels
Vitamins	See text and Table 31.2
Insulin, regular	Adjusted/blood glucose levels
Caloric content	
50% dextrose	425 kcal/treatment
20% lipid emulsion	500 kcal/treatment
Total	925 kcal/treatment

IDPN, intradialytic parenteral nutrition.

3. **Potential risks of IDPN.** Hypo- and hyperglycemia, especially in patients with diabetes mellitus, should be anticipated and appropriately treated. Prolonged use of IDPN may lead to increased risk of infections, abnormalities in lipid profile, and accumulation of fat tissue rather than muscle. When amino acids are given as part of IDPN, there typically will be about a 0.2 decline in the treatment Kt/V (McCann, 1999). This decline in Kt/V is thought to be due to a sudden increase in urea generation associated with amino acid infusion, which elevates the postdialysis serum urea nitrogen level.
- E. **Total parenteral nutrition (TPN).** TPN is used in patients with severe nutritional deficits who cannot receive adequate nutritional intake from oral supplements, intraperitoneal amino acids, or IDPN. General guidelines for the formulation of a typical TPN solution are outlined in Table 31.6.
1. **Carbohydrates.** Approximately 50%–70% of nonprotein calories in TPN are provided from glucose. Glucose is usually provided as 70% D-glucose to minimize the amount of fluid administered. The precise amount of D-glucose given is dependent on the calculated energy intake indicated for an individual patient. Each milliliter of 70% dextrose provides 2.38 kcal.
 2. **Amino acids.** There is much controversy regarding the optimal mix of essential and nonessential amino acids used in TPN solutions. Some authors report that essential amino acids can be used more efficiently than larger quantities of essential and nonessential amino acids, whereas others report the development of nausea, vomiting, and metabolic acidosis when only essential amino acids are administered. Most commercial crystalline amino acid solutions provide a mix of essential and nonessential amino acids.

TABLE

Composition of “typical” total parenteral nutrition solutions for hospitalized patients with kidney disease

Component	Amount	
70% dextrose (d-glucose)	350 g (500 mL)	
8.5% crystalline amino acids (essential and nonessential)	42.5 g (500 mL)	
20% lipids or 10% lipids	100 g or 50 g (in 500 mL)	
Electrolytes (general guidelines)^a		
Sodium	See text	
Chloride	See text	
Potassium	<35 mmol/d	
Acetate	35–40 mmol/d	
Calcium	5 mmol/d	
Phosphorus	5–10 mmol/d	
Magnesium	2–4 mmol/d	
Iron	2 mg/d	
Vitamins	See text and Table 31.2	
Caloric content		
Solution		
Administration Rate:	40 mL/hr or 960 mL/d	60 mL/hr or 1,440 mL/d
70% dextrose	762 kcal/d	1,142 kcal/d
20% lipid emulsion (LE)	640 kcal/d	960 kcal/d
Total with 20% LE	1,402 kcal/d	2,102 kcal/d
70% dextrose	762 kcal/d	1,142 kcal/d
10% lipid emulsion (LE)	352 kcal/d	528 kcal/d
Total with 10% LE	1,114 kcal/d	1,670 kcal/d

^aThe specific amount of electrolytes given should be modified on the basis of the patient's clinical condition and serum concentration of electrolytes. The guidelines listed include electrolytes contributed by the infusion of amino acids. Use of a total parenteral nutrition sodium level of about 140 mmol/L will prevent hyponatremia, but requires either daily dialysis or continuous renal replacement therapy for adequate volume control.

- Lipids.** Lipids can provide up to 50% of the nonprotein calories in TPN solutions. Lipid emulsions are usually available in 10% and 20% solutions; the latter provides 2.0 kcal/mL. Lipids should be given over a 12- to 24-hour period to decrease the risk of decreased functioning of the reticuloendothelial system. Some authors recommend decreasing the amount of lipids given by 50% if the patient is septic or at a high risk for sepsis. There is some controversy regarding the ratio of polyunsaturated to saturated fatty acids that is preferable in acutely ill dialysis patients, with most authors

recommending a ratio between 1.0 and 2.0. If patients develop marked hypertriglyceridemia, lipid infusions can be provided once or twice weekly instead of daily.

4. **Electrolytes.** The amount of sodium and chloride, the two principal ions, depends on whether continuous renal replacement therapy (CRRT) or intermittent hemodialysis (IHD) is being done. With CRRT, the TPN solutions, as well as most other infusates, should have a sodium level close to 140 mM. With IHD, a lower TPN solution sodium level is often used (40–80 mM) in order to minimize the risk of causing volume overload and pulmonary edema. With SLED (sustained low-efficiency dialysis) given daily, higher TPN solution sodium concentrations often can be used to limit hyponatremia. Acetate, which is metabolized to bicarbonate, is traditionally added to TPN solutions when alkalization of the serum is desired. The high glucose load plus the anabolism induced by TPN solutions can result in hypokalemia, hypophosphatemia, and hypomagnesemia owing to intracellular shifts of these ions. Therefore, blood levels of these electrolytes should be monitored frequently, and they should be added to the TPN solution or infused separately, as needed.
5. **Vitamins.** Little research has been performed on vitamin requirements in patients with AKI. In general, vitamin supplementation during TPN should be similar to that provided to maintenance dialysis patients (Table 31.2).
6. **Minerals and trace elements.** Iron should be supplemented to help provide for effective erythropoiesis. Zinc is sometimes given on the basis of some evidence that it accelerates wound healing. Other trace elements probably need not be supplemented unless the patient receives TPN for more than 3 weeks.

F. **Intraperitoneal infusion of amino acids in peritoneal dialysis patients**

1. **Indications and benefits.** Amino acid dialysate should be considered in peritoneal dialysis patients with PEW who are unable to tolerate or are not suitable for oral nutritional supplements. The evidence of benefit of amino acid dialysate is conflicting; benefit is more likely when significant hypoalbuminemia is present. (Jones 1998)
2. **Composition, infusion, and complications.** Usually, the amino acid dialysate solution consists of both essential and nonessential amino acids. It is given as the overnight exchange in continuous ambulatory peritoneal dialysis (CAPD) patients or as the long daytime dwell in continuous cycling peritoneal dialysis patients in order to maximize protein absorption. The osmotic effect of a 1.0% amino acid dialysate solution is similar to that of a 2.0% dextrose solution. Complications of utilizing amino acid dialysate solutions include anorexia, nausea, vomiting, and an increase in SUN levels, and are more common when patients receive two amino acid dialysate dwells per day versus one per day.

- #### G. **Adjuvant therapies and exercise.** Other therapies that can be considered include growth hormone, anabolic steroids, exercise, appetite stimulants, and anti-inflammatory interventions. Evidence of the effectiveness of these interventions is weak. In maintenance dialysis patients, endurance exercise has been associated with an improvement in the rate of glucose disappearance and a reduction in fasting plasma insulin levels; in addition, with exercise, plasma triglyceride values decrease, and high-density lipoprotein (HDL)

cholesterol concentrations increase. Other benefits of exercise include an increase in muscle size and strength, and improvement in endurance.

References and Suggested Readings

- Arora SK, McFarlane SI. The case for low carbohydrate diets in diabetes management. *Nutr Metab*. (Lond). 2005;2:16.
- Burrowes JD, et al. Effects of dietary intake, appetite, and eating habits on dialysis and non-dialysis treatment days in hemodialysis patients: cross-sectional results from the HEMO study. *J Ren Nutr*. 2003;13:191–198.
- Caluwé R, et al. Vitamin K2 supplementation in haemodialysis patients: a randomized dose-finding study. *Nephrol Dial Transplant*. 2014;29:1385-90.
- Cano N, et al. ESPEN guidelines on enteral nutrition: adult renal failure. *Clin Nutr*. 2006;25:295–310.
- Cano NJ, et al. Intradialytic parenteral nutrition does not improve survival in malnourished hemodialysis patients: a 2-year multicenter, prospective, randomized study. *J Am Soc Nephrol* 2007;18:2583–2591.
- Cano NJ, et al. ESPEN Guidelines on Parenteral Nutrition: adult renal failure. *Clin Nutr*. 2009;28:401–414.
- Carrero JJ, et al. Etiology of the protein-energy wasting syndrome in chronic kidney disease: a consensus statement From the International Society of Renal Nutrition and Metabolism (ISRNM). *J Ren Nutr*. 2013;23:77–90.
- Chowdhury R, et al. Association of dietary, circulating, and supplement fatty acids with coronary risk: a systematic review and meta-analysis. *Ann Intern Med*. 2014;160:398–406.
- Chumlea WC, et al; Nutritional status assessed from anthropometric measures in the HEMO study. *J Ren Nutr*. 2003;13:31–38.
- Churchill DN, Taylor W, Keshaviah PR. Adequacy of dialysis and nutrition in continuous peritoneal dialysis: association with clinical outcomes. Canada-USA (CANUSA) Peritoneal Dialysis Study Group. *J Am Soc Nephrol*. 1996;7:198–207.
- Di Filippo S, et al. Reduction in urea distribution volume over time in clinically stable dialysis patients. *Kidney Int*. 2006;69:754–759.
- Di Iorio BR, et al. A systematic evaluation of bioelectrical impedance measurement after hemodialysis session. *Kidney Int*. 2004;65:2435–2440.
- Dombros N, et al. for the EBPG Expert Group on Peritoneal Dialysis. European best practice guidelines for peritoneal dialysis. 8 Nutrition in peritoneal dialysis. *Nephrol Dial Transplant*. 2005;20(suppl 9):ix28–ix33.
- Duerksen DR, et al. The validity and reproducibility of clinical assessment of nutritional status in the elderly. *Nutrition*. 2000;16:740–744.
- Ghandour H, et al. Distribution of plasma folate forms in hemodialysis patients receiving high daily doses of L-folinic or folic acid. *Kidney Int*. 2002;62:2246–2249.
- Gracia-Iguacel C, et al. Subclinical versus overt obesity in dialysis patients: more than meets the eye. *Nephrol Dial Transplant*. 2013;28(suppl 4):iv175–iv181.
- Himmelfarb J, et al. Provision of antioxidant therapy in hemodialysis (PATH): a randomized clinical trial. *J Am Soc Nephrol*. 2014;25:623–633.

- Ikizler TA, Cano NJ, Franch H et al. Prevention and treatment of protein energy wasting in chronic kidney disease patients: a consensus statement by the International Society of Renal Nutrition and Metabolism. *Kidney Int.* 2013;84:1096–1107.
- Institute of Medicine. *Dietary reference intakes: water, potassium, sodium, chloride, and sulfate*. Washington, DC, National Academy Press, 2004.
- Jones M, et al. Treatment of malnutrition with 1.1% amino acid peritoneal dialysis solution: results of a multicenter outpatient study. *Am J Kidney Dis.* 1998;32:761–769.
- Kaizu Y, et al. Association between inflammatory mediators and muscle mass in long-term hemodialysis patients. *Am J Kidney Dis.* 2003;42:295–302.
- Kalantar-Zadeh K, et al. A malnutrition-inflammation score is correlated with morbidity and mortality in maintenance hemodialysis patients. *Am J Kidney Dis.* 2001;38:1251–1263.
- Kalantar-Zadeh K, et al. Food intake characteristics of hemodialysis patients as obtained by food frequency questionnaire. *J Ren Nutr.* 2002;12:17–31.
- Kalantar-Zadeh K, et al. Appetite and inflammation, nutrition, anemia, and clinical outcome in hemodialysis patients. *Am J Clin Nutr.* 2004;80:299–307.
- Kalantar-Zadeh K, et al. Understanding sources of dietary phosphorus in the treatment of patients with chronic kidney disease. *Clin J Am Soc Nephrol.* 2010;5: 519–530.
- Kalantar-Zadeh K, Ikizler TA. Let them eat during dialysis: an overlooked opportunity to improve outcomes in maintenance hemodialysis patients. *J Ren Nutr.* 2013;23:157–163.
- Kasama R, et al. Vitamin B6 and hemodialysis: the impact of high flux/high-efficiency dialysis and review of the literature. *Am J Kidney Dis.* 1996;8:680–686.
- Kaysen GA. The microinflammatory state in uremia: causes and potential consequences. *J Am Soc Nephrol.* 2001;12:1549–1557.
- Kaysen GA, et al; and the FHN Trial Group. The effect of frequent hemodialysis on nutrition and body composition: frequent Hemodialysis Network Trial. *Kidney Int.* 2012;82:90–99.
- Kobayashi I, et al. Geriatric Nutritional Risk Index, a simplified nutritional screening index, is a significant predictor of mortality in chronic dialysis patients. *Nephrol Dial Transplant.* 2010;25:3361–3365.
- Kogirima M, et al. Low resting energy expenditure in middle-aged and elderly hemodialysis patients with poor nutritional status. *J Med Invest.* 2006;53:34–41.
- Kopple JD. National kidney foundation K/DOQI clinical practice guidelines for nutrition in chronic renal failure. *Am J Kidney Dis.* 2001; 37(suppl 2):S66–S70.
- Kramer HJ, et al. Increasing body mass index and obesity in the incident ESRD population. *J Am Soc Nephrol.* 2006;17:1453–1459.
- Krueger T, et al. Vitamin K1 to slow vascular calcification in haemodialysis patients (VitaVasK trial): a rationale and study protocol. *Nephrol Dial Transplant.* 2014;29:1633-1638.
- McCann L, et al. Effect of intradialytic parenteral nutrition on delivered Kt/V. *Am J Kidney Dis.* 1999;33:1131–1135.
- Mushnick R, et al. Relationship of bioelectrical impedance parameters to nutrition and survival in peritoneal dialysis patients. *Kidney Int.* 2003;87(suppl):S53–S56.
- National Kidney Foundation. *K/DOQI clinical practice guidelines for nutrition in chronic renal failure*. New York, NY: National Kidney Foundation, 2001.
- Pupim LB, Cuppari L, Ikizler TA. Nutrition and metabolism in kidney disease. *Semin Nephrol.*

2006;26:134–157.

Rocco MV, et al; for the HEMO Study Group. The effect of dialysis dose and membrane flux on nutritional parameters in hemodialysis patients: results of the HEMO study. *Kidney Int.* 2004;65:2321–2334.

Rocco MV. Does more frequent hemodialysis provide dietary freedom? *J Ren Nutr.* 2013;23:259–262.

Siew ED, Ikizler TA. Insulin resistance and protein energy metabolism in patients with advanced chronic kidney disease. *Semin Dial.* 2010;23:378–382.

Soop M, et al. Energy expenditure in postoperative multiple organ failure with acute renal failure. *Clin Nephrol.* 1989;31:139–145.

Stein A, et al. Role of an improvement in acid-base status and nutrition in CAPD patients. *Kidney Int.* 1997;52:1089–1095.

Stenvinkel P, Zoccali C, Ikizler TA. Obesity in CKD—What Should Nephrologists Know? *J Am Soc Nephrol.* 2013;24:1727–1736.

Stratton RJ, et al. Multinutrient oral supplements and tube feeding in maintenance dialysis: a systematic review and meta-analysis. *Am J Kidney Dis.* 2005;46:387–405.

van Biesen W, et al. A multicentric, international matched pair analysis of body composition in peritoneal dialysis versus haemodialysis patients. *Nephrol Dial Transplant.* 2013;28:2620–2628.

Wang AY, et al. Important factors other than dialysis adequacy associated with inadequate dietary protein and energy intakes in patients receiving maintenance peritoneal dialysis. *Am J Clin Nutr.* 2003;77:834–841.

Wang W, et al. Outcomes associated with intradialytic oral nutritional supplements in patients undergoing maintenance hemodialysis: a quality improvement report. *Am J Kidney Dis.* 2012;60:591–600.

Weiner DE. Oral intradialytic nutritional supplement use and mortality in hemodialysis patients. *Am J Kidney Dis.* 2014;63:276–285.

More than 40% of all new patients starting dialysis in the United States are diabetic. Provision of maintenance dialysis for this group can be a challenging task. Morbidity and mortality are substantially higher in diabetic patients maintained on dialysis than in their nondiabetic counterparts, with cardiovascular disease and infection being the leading causes of death. In the United States, the 3-year survival rate of diabetic patients maintained on dialysis is only about 50% (USRDS, 2013).

- I. **WHEN TO INITIATE DIALYSIS.** Early referral to nephrologists of diabetic patients with renal failure reportedly improves outcomes. Previous guidelines emphasized initiation of dialysis prior to the appearance of frank uremic manifestations (at an estimated glomerular filtration rate [eGFR] of ≤ 15 mL/min per 1.73 m²). However, a recent randomized controlled trial that examined mortality versus time of dialysis initiation, the IDEAL study, found no difference in survival between early or late initiation of dialysis, and in that study, approximately one-third of the participants were diabetic (Cooper, 2010).
- II. **HEMODIALYSIS VERSUS PERITONEAL DIALYSIS.** The potential problems with each form of dialysis are listed in Table 32.1. Long-term peritoneal dialysis (PD) in diabetic patients may complicate control of blood sugar because altered glucose homeostasis is stressed further by the large amount of glucose administered via the dialysis solution. In addition, glucose absorption from the abdominal cavity decreases appetite. Many PD patients have difficulty ingesting the higher recommended amount of protein for PD patients (1.2 g/kg daily). On the other hand, the incidence and severity of hypoglycemic episodes is reduced in continuous ambulatory peritoneal dialysis (CAPD) or automated peritoneal dialysis (APD) compared with hemodialysis (HD) because of the constant or near-constant presence of glucose in the abdomen. Rates of infection (peritonitis, exit-site and tunnel infections) and rates of catheter replacement are similar between diabetic and nondiabetic patients on PD. Administration of insulin intraperitoneally appears to increase slightly the risk of peritonitis in PD patients and, though appealing on physiologic grounds, is now less commonly employed. With HD, coexisting blood vessel disease often hinders creation of an adequate, long-lasting vascular access. The survival rates of both arteriovenous (AV) fistulas and grafts are substantially reduced in diabetic compared with nondiabetic patients. A small fraction of diabetic patients develop severe hand ischemia after creation of an ipsilateral AV fistula, which can lead to gangrene and need for amputation; prompt ligation of the fistula is indicated in such instances. Because of autonomic

nervous system dysfunction or cardiac diastolic dysfunction, diabetic patients are at increased risk for hypotension during HD. Problems with vascular access and increased risk of hypotension may cause diabetic patients to receive a lesser amount of dialysis (in terms of fractional urea clearance [Kt/V]) than their nondiabetic counterparts.

Lower extremity amputations are frequent in diabetic patients on either HD or PD. The rate of progression of retinopathy appears to be similar between patients treated with HD and PD. Although visual impairment impedes training for CAPD and makes it difficult for the patient to perform the exchange procedure properly, even blind diabetic patients can be trained to perform CAPD without a helper. When properly instructed, their risk of developing peritonitis is only slightly greater than the risk in sighted diabetics. A number of devices are available to help visually impaired patients connect the dialysis solution container to the peritoneal transfer set (see Chapter 22). APD is a better therapeutic choice for blind diabetic patients because many APD schedules require the performance of only one “on” and one “off” procedure daily.

Earlier reports from the U.S. Renal Data System suggested that mortality is higher in diabetic patients, and especially diabetic women, on PD than in those on HD. Patient selection biases and/or inadequate PD may have affected these observations. In a subsequent large analysis, mortality risk was actually higher with HD than PD among younger diabetics with no comorbidity but lower with HD in older diabetics, especially if they had comorbidities (Vonesh, 2004). These results are undoubtedly also affected by selection biases. Comorbidity and malnutrition have much larger effects on mortality than the dialysis modality. Meticulous management and prevention of cardiovascular and infectious morbidity may lead to substantial improvement in patient survival.

TABLE

32.1

Dialysis Modalities for Diabetics

Modality	Advantages	Disadvantages
Hemodialysis	<ul style="list-style-type: none"> Very efficient Frequent medical follow-up (in-center) No protein loss to dialysate 	<ul style="list-style-type: none"> May be poorly tolerated in patients with advanced cardiac disease Multiple arteriovenous access surgeries often required; risk of severe hand ischemia Relatively high incidence of hypotension during dialysis session Predialysis hyperkalemia Prone to hypoglycemia
CAPD	<ul style="list-style-type: none"> Good cardiovascular tolerance No need for arteriovenous access Good control of serum potassium Lower risk of hypoglycemia 	<ul style="list-style-type: none"> Peritonitis, exit-site infection, and tunnel infection (however, risks similar to those in nondiabetic dialysis patients) Protein loss to dialysate Increased intra-abdominal pressure effects (hernias, fluid leaks, etc.) Often needs helper (e.g., some blind patients)
APD	<ul style="list-style-type: none"> Good cardiovascular tolerance No need for arteriovenous access Good control of serum potassium Lower risk of hypoglycemia Good for blind diabetics Peritonitis risk slightly less than for 	<ul style="list-style-type: none"> Protein loss to dialysate

CAPD, continuous ambulatory peritoneal dialysis; APD, automated peritoneal dialysis.

III. **DIET.** Whatever the mode of dialysis therapy, diabetic patients generally show evidence of wasting and malnutrition. Many factors contribute, including chronic inflammation, inadequate food intake, diabetic gastroparesis and enteropathy, and the catabolic stress associated with frequent intercurrent illness. In the event of serious illness, diabetic dialysis patients often require early and intensive nutritional support.

A. **Routine dietary prescription.** The diets advocated for nondiabetic HD and PD patients in Chapter 31 also apply to patients with diabetes. In an anuric diabetic patient being treated with HD, the stringent sodium, potassium, and fluid restrictions described in Chapter 31 should be applied. Special effort should be made to limit intake of simple sugars and saturated fats.

1. **Carbohydrates percentage.** The general recommendation for a diabetic diet is for 50%–60% of intake to be carbohydrates, with some interest in using an even lower carbohydrate diet in diabetic patients (Arora, 2005). In patients undergoing PD, the glucose calories supplied from the PD regimen (usually around 400 kcal) should be subtracted from the dietary carbohydrate prescription, and perhaps in selected patients with hypertriglyceridemia, a focus on avoiding all high-glycemic-index carbohydrates might be of benefit.

2. **Dietary “glycotoxins” from advanced glycosylation end products (AGEs).** Levels of AGEs are increased in food that has been cooked at high temperature, especially if food contains a high proportion of fat. Dietary AGE ingestion has been linked to adverse lipid profiles and inflammatory markers in diabetic patients (Uribarri, 2005) and to increased serum levels of AGEs in end-stage kidney disease (ESKD) patients, with perhaps increased risk of access thrombosis. Any reason to additionally restrict food in ESKD patients should be done with caution, given the high prevalence of malnutrition; however, some attention to food preparation with a focus on minimizing formation of AGEs (avoidance of deep frying, extensive heating) might be a consideration.

B. **Diabetic gastroparesis and enteropathy.** The diagnosis of diabetic gastroparesis is often made on the basis of symptoms of nausea, vomiting, early satiety, and postprandial fullness. Since other treatable conditions can have similar symptoms, an esophagogastroduodenoscopy should be performed before symptoms are ascribed to gastroparesis alone. The traditional “gold standard” to establish the diagnosis of gastroparesis is scintigraphic measurement of gastric emptying. However, a drawback is that scintigraphy exposes patients to radiation and is therefore not ideally suited for repeated investigations (to monitor the response to therapy). This problem can be overcome by ^{13}C -labeled acetate and octanoic acid breath tests. Diabetic gastroparesis can be associated with poor food intake and unpredictable nutrient absorption; the result can be hypoglycemia alternating with hyperglycemia.

In such patients, small, frequent (up to six times per day) feedings may improve symptoms. The pharmacologic treatment of gastroparesis in diabetic persons on dialysis is

unsatisfactory. Metoclopramide given in a small starting dose (5 mg before meals) with small increments until results are seen is usually the first drug prescribed. This drug is associated with a high incidence of extrapyramidal complications in dialysis patients, particularly at higher doses, and its effects are often temporary. Other “prokinetic” gastrointestinal motility drugs, such as domperidone, motilin agonists, or ondansetron, may be tried.

Diabetic enteropathy results from functional impairment of the enteric nervous system and can result in disordered motility of the small bowel and the colon, resulting in either prolonged or shortened bowel transit times. Diabetic enteropathy with resulting diarrhea can complicate alimentation, causing debilitation, poor food intake, and hypoglycemia. Severe cases of diabetic enteropathy can be treated with a trial of broad-spectrum antimicrobials (e.g., doxycycline in a dose of 50 or 100 mg daily) to combat bacterial overgrowth in the intestine. Loperamide hydrochloride (up to 10 mg daily) to decrease bowel motility is also useful.

IV. CONTROL OF BLOOD SUGAR

- A. **Alteration of insulin metabolism by CKD.** In uremic patients (both diabetic and nondiabetic), insulin secretion by the β cells of the pancreas is reduced, and the responsiveness of peripheral tissues (e.g., muscle) to insulin is depressed; that is, there is increased insulin resistance. Insulin resistance occurs in almost all uremic patients and results in hyperglycemia. The literature suggests that hepatic glucose production and uptake are normal in uremia and that skeletal muscle is the primary site of insulin resistance, probably via a postreceptor defect (Castellino, 1992). However, many of the actions of insulin are maintained in renal failure, including potassium uptake by the cells and inhibition of proteolysis.

The kidney is pivotal in insulin metabolism in healthy individuals. Insulin is freely filtered by the glomerulus, with 60% cleared via glomerular filtration and 40% by extraction from the peritubular vessels; less than 1% of filtered insulin is excreted in the urine unchanged. Approximately 6–8 units of insulin are degraded by the kidney each day, roughly 25% of the daily production of insulin by the pancreas. Renal metabolism is enhanced in diabetic subjects receiving exogenous insulin, since injected insulin bypasses the liver and goes directly into the systemic circulation. The rate of insulin catabolism is decreased owing to decreased renal mass, and therefore the half-life of any insulin present in the circulation is prolonged. The reduction in insulin clearance is also mediated by a decline in hepatic metabolism. All of these abnormalities are only partially corrected after institution of maintenance dialysis therapy.

1. **Abnormal glucose tolerance tests in all dialysis patients.** The glucose tolerance test cannot be used to diagnose diabetes in dialysis patients because the rise in serum glucose concentration will be greater and more prolonged than normal in all dialysis patients as a result of uremia-induced insulin resistance. However, fasting serum glucose concentrations are normal in nondiabetic HD patients; a high level suggests the presence of diabetes. In PD patients, a true fasting state is never achieved owing to constant absorption of glucose from the dialysis solution. In this group, unless

peritonitis is present, the “fasting” serum glucose value rarely exceeds 160 mg/dL (8.9 mmol/L), even when using 4.25% dextrose dialysis solution; higher levels suggest that the patient has diabetes. In CAPD patients using icodextrin, serum glucose values may be spuriously overestimated by auto-analyzers that use the glucose dehydrogenase method of sample analysis (Tsai, 2010).

2. **Increased sensitivity to insulin.** In diabetic dialysis patients being treated with exogenous insulin, the importance of reduced insulin catabolism overrides the impact of insulin resistance; when exogenous insulin is administered, its effect may be intensified and prolonged. Thus, smaller-than-usual doses should be given. Bolus administration of moderately large intravenous doses (e.g., 15 units of regular insulin), even when ketosis is present, can result in severe hypoglycemia. Hypoglycemia can occur also after administration of the longer-acting insulins, such as isophane insulin (NPH) and insulin glargine.
3. **Hyperglycemia.** The clinical presentation of hyperglycemia is modified when renal function is absent. The absence of the “safety valve” effect of glycosuria may result in the development of severe hyperglycemia (serum glucose level >1,000 mg/dL [56 mmol/L]). Severe hyperosmolality with accompanying alteration of mental status is unusual because of the absence of water loss induced by osmotic diuresis. Indeed, even extreme hyperglycemia is often asymptomatic in dialysis patients (Al-Kudsi, 1982). However, manifestations can include thirst, weight gain, and, on occasion, pulmonary edema or coma (Tzamaloukas, 2004). Diabetic ketoacidosis, frequently accompanied by severe hyperkalemia and coma, can develop in insulin-dependent dialysis patients. Management of hyperglycemia with or without ketoacidosis differs from that in patients without renal failure in that administration of large amounts of fluid is unnecessary and generally contraindicated. All of the clinical and laboratory abnormalities of hyperglycemia are corrected by insulin administration, which often is the only treatment needed. To manage severe hyperglycemia, one can administer a continuous infusion of low-dose regular insulin (starting at 2 units/hr) with close clinical monitoring and measurement of serum glucose and potassium concentrations at 2- to 3-hour intervals. If severe hyperkalemia is present, electrocardiography should be done. Emergency dialysis may be needed in patients with hyperglycemia and either severe pulmonary edema or life-threatening hyperkalemia.
4. **Hypoglycemia.** Avoidance of hypoglycemia is often the rate-limiting step in obtaining good glucose control. Treatment for hypoglycemia can lead to rebound hyperglycemia and erratic glycemetic control. There are many factors that contribute to hypoglycemia, including decreased caloric intake due to attendant anorexia, decreased insulin clearance, reduced renal gluconeogenesis due to the reduction in functioning renal mass, impaired release of the counterregulatory hormone epinephrine due to the autonomic neuropathy of renal failure, decreased hepatic metabolism of insulin, and decreased metabolism of drugs that might promote a reduction in the plasma glucose concentration such as alcohol, propranolol and other nonselective adrenergic blockers. Additionally, hypoglycemic unawareness and gastroparesis may increase the risk for hypoglycemia. In diabetic patients, HD solution should always contain about 90 mg/dL

(5 mM) glucose; if glucose is not added, severe hypoglycemia during or soon after the HD session can result (Burmeister, 2012). Higher (200 mg/dL, 11 mM) dialysate glucose levels may increase the frequency of hyperglycemia (Raimann, 2012), and may not protect against hypoglycemic episodes better than the 90 mg/dL option.

B. Insulin therapy. Achieving and maintaining reasonable glucose control while avoiding hypoglycemia is the challenge in managing patients with diabetes on dialysis. Reasonable glycemic control in diabetic patients on chronic dialysis is considered a fasting blood glucose below 140 mg/dL and a 1-hour postprandial value of less than 200 mg/dL with an HbA1c between 7% and 8%. Several large studies have found no significant correlation between glycemic control and survival, yet a much higher risk of hypoglycemia with stricter glycemic control (Williams, 2010). The HbA1c target that is associated with the best outcome in dialysis patients has not been established (KDOQI clinical practice guidelines, 2005). It has been suggested that measurement of glycated albumin more accurately assesses glycemic control in this population as it is not affected by the Hb level, but this test is not readily available. Another issue with HbA1c is that it can be affected (reduced) by administration of ESAs and iron (Ng, 2010).

Irreversibly and slowly formed compounds that are the result of nonenzymatic glycosylation of proteins, the so-called AGEs, alter the structure and function of vascular basement membranes, stimulate the production of growth factors, and alter the function of intracellular proteins. In PD patients, AGE deposition in the peritoneal membrane is associated with an increase in permeability and excessive protein losses in the dialysate (Nakamoto, 2002).

- 1. Insulin regimens.** The following dose recommendations have been made for insulin dosage in the setting of kidney disease (Snyder, 2004):
 - a. No dose adjustment is required if the GFR is above 50 mL/min.
 - b. Reduce the insulin dose by 25% when the GFR is 10–50 mL/min.
 - c. Reduce the dose by 50% when the GFR is less than 10 mL/min.
- 2. Example using glargine and rapid-acting insulin.** As an example, a common weight-based dose might be 0.6 units/kg total daily dose of insulin (Murphy, 2009). Reducing this by 50% for ESKD changes this to 0.3 units/kg total daily dose of insulin (Baldwin, 2012). Of this, half should be given as basal insulin and half as mealtime bolus insulin. This would mean that 0.15 units/kg would be given in the morning as a basal dose, and then the remainder (0.15 units/kg) divided up by the number of meals, given as rapid-acting insulin; say 0.05 units/kg at breakfast, lunch, and supper. For a 70- kg patient, the total dose of insulin would be $70 \text{ kg} \times 0.3 \text{ units/kg} = 21 \text{ units}$. Half of this, or approximately 10 units, would be given as the basal once-daily glargine, and the remaining 11 units would be given over the 3 daily meals, or 3–4 units rapid-acting insulin per meal.
- 3. Example using NPH plus a rapid-acting insulin.** When using NPH with rapid-acting insulin, the total daily dose would be the same (21 units), but two-thirds of the daily dose (or 14 units) should be given as NPH, with two-thirds of the NPH (9 units) given at breakfast and the remaining 5 units of NPH at bedtime. The non-NPH remainder of the total daily dose (7 units) would then be given as rapid-acting insulin, giving 3 units at breakfast and 4 units at dinner. A lunchtime dose of rapid-acting insulin is not needed, as the

morning dose of NPH is peaking at this time and would cover this meal.

4. **Other insulin combinations.** New basal and rapid-acting insulin analogs are expected to be available for clinical use in 2015, but have not been studied in patients with ESKD (Danne, 2011).
5. **Timing of mealtime insulin.** While mealtime insulin is generally given about 5 minutes before the meal, some patients prefer to take it just after the meal. This is somewhat safer in that it allows patients to reduce the insulin dose if the entire meal is not eaten. For example, if only 50% of the meal is eaten, only 50% of the dose is taken. Finer enhancements of the mealtime insulin dose include modification by carbohydrate counting (if the patient is willing to learn and implement this technique) and by addition to or subtraction from the mealtime insulin dose using a correction factor scale (if the patient is willing to check his or her glucose values before each meal).
6. **Glucose monitoring.** It is important that blood glucose levels be monitored closely and that individually appropriate dose adjustments in insulin therapy be made. Patients receiving insulin therapy at home should monitor their glucose levels at least twice daily, in the morning and at bedtime. With both of the above regimens, a reasonable “correction dose” of insulin would be 1 extra unit of daily insulin for every 50 mg/dL glucose above target (for example the target level might be 150 mg/dL) for that patient.
7. **Effect of hemodialysis on insulin dose.** HD has been shown to improve both tissue sensitivity to insulin and insulin secretory response to glucose (DeFronzo, 1978). The mechanism by which this occurs is unknown, but improved acid–base status may be contributing. When HD is initiated, the insulin requirement in any given patient may change, depending on the net balance between improved tissue sensitivity and improved hepatic insulin metabolism. One cannot readily predict insulin requirements in this setting, and careful observation of the patient is essential.

In HD patients, several different insulin regimens can be used to achieve glycemic control. The glargine- and NPH-based regimens described above can be used as a starting point. Some experts feel that long-acting insulin preparations should be avoided, while others feel that such agents should be used, but there are no head-to-head comparisons of different regimens in dialysis patients.

With regard to insulin therapy on dialysis versus nondialysis days, the usual baseline dose is normally given, but the timing of mealtime doses is often changed when dialysis alters the times when food is consumed.

8. **Effect of peritoneal dialysis on insulin dose.** The glucose contained in peritoneal dialysate increases the need for blood glucose–lowering therapy, and more insulin is often required because of insulin resistance and the glucose load absorbed from the hypertonic dialysate. A 1.5-percent dextrose (glucose monohydrate, MW 198) dialysate solution, for example, has a glucose (MW 180) concentration of $1,500 \times (180/198) = 1,364$ mg (76 mmol/L), well above that in the plasma. On the other hand, in some PD patients less insulin can be required than anticipated owing to decreased carbohydrate intake and to prolongation of the duration of action of insulin resulting from reduced renal and hepatic insulin clearance.

To help maintain near-normal glycemia during PD, blood sugar in patients treated with

CAPD or APD can be controlled with intraperitoneal insulin, although this is now done only rarely. Use of the intraperitoneal route has the advantages of a continuous or nearly continuous presence of insulin, elimination of the need for injections, and a more physiologic route of insulin supply to the liver via the portal vein, mimicking the way that pancreatic insulin reaches the liver (Tzamaloukas, 1991). Disadvantages are the potential for bacterial contamination of dialysate during injection of insulin into the bags, need for somewhat higher daily total insulin doses due to losses of insulin with the spent dialysate, and, perhaps of greatest concern, the risk of peritoneal fibroblastic proliferation and hepatic subcapsular steatosis (Maxwell, 1991). If intraperitoneal insulin is used, it is recommended that a long, 3.8-cm (1.5 in) needle be used to ensure that the full dose of insulin is injected into the dialysis solution container rather than being trapped in the infusion port; the dialysis solution container should be inverted several times after injection to ensure proper mixing. For intraperitoneal insulin protocols, please refer to previous editions of this Handbook.

It is important to remember that icodextrin and maltose, which are contained in some PD solutions, can interfere with, or cause falsely elevated glucose results with, some self-monitoring methods, possibly leading to inappropriate therapy (Tsai, 2010; Firanek, 2013).

9. **Use of an insulin infusion pump.** In fragile type 1 diabetic patients where frequent hypoglycemia is a problem, continuous subcutaneous insulin injection can be of benefit. In such cases, the insulin infusion may be shut off 1 hour or so prior to HD and resumed shortly after the dialysis session is completed (Atherton, 2004).

C. **Oral hypoglycemic agents and noninsulin injectable agents.** These agents are useful adjuncts in the treatment of diabetic patients and are used by many nephrologists. Suggested agents and appropriate doses are listed in Table 32.2. In a 2010 survey of U.S. dialysis patients with diabetes, 80% were recorded as receiving some form of glycemic therapy, and of these, 49/80 were being managed with insulin alone, 8/80 with insulin plus some form of oral medication, and 23/80 with an oral agent only. Of the oral agents being used in 2010, the great majority were either sulfonylureas or thiazolidinediones, although this may change as more information and experience with the newer agents become available.

1. **Sulfonylureas.** Sulfonylureas are insulin secretagogues that bind to the sulfonylurea receptor, a part of the potassium channel, on pancreatic β cells. They cause potassium channel closure with subsequent membrane depolarization, which, in turn, causes opening of voltage-gated calcium channels. This allows for a sudden increase in intracellular calcium, which causes preformed insulin to be released from intracellular secretory granules. First generation sulfonylureas (acetohexamide, chlorpropamide, tolazamide, and tolbutamide) are almost never used anymore. The second generation drugs (glipizide, glyburide, and glimepiride) are still fairly widely employed. All the second generation sulfonylureas undergo hepatic metabolism with a variable percentage of renal excretion (Spiller, 2006). Glyburide and glimepiride have active metabolites with relatively long half-lives that are renally excreted and so are not recommended for end-stage kidney disease (ESKD) patients. The metabolite of **glipizide** has little or no hypoglycemic activity and a short half-life of 2–4 hours. Therefore, even though its renal excretion is high (80%–85%), glipizide is the

sulfonylurea of choice in dialysis patients. However, sulfonylureas as a class show a relatively high incidence of hypoglycemia, plus many drugs frequently used in dialysis patients can either antagonize (phenytoin, nicotinic acid, diuretics) or enhance (salicylates, warfarin, ethanol) the hypoglycemic action of sulfonylureas. Another reason that sulfonylureas are not optimal in the ESKD population is that their mechanism of action (facilitating insulin release) presupposes that the individual being treated is still producing some endogenous insulin. In people with type 2 diabetes, endogenous insulin, assessed by C-peptide measurements, was highest in people with recently diagnosed disease and progressively decreased in people as the duration of diabetes increased. (Duckworth, 2011). Since most people on dialysis will have had diabetes for a fairly long time, many will be producing little or no endogenous insulin and so will be unable to respond to sulfonylureas.

- Metformin.** Metformin, a member of the biguanide class, is perhaps the most widely used oral agent to treat type 2 diabetes in patients with normal renal function and has several distinct advantages. Metformin use is associated with a very low incidence of hypoglycemia, weight loss instead of weight gain, and a favorable effect on serum lipids. Its mechanism of action is to acutely decrease hepatic glucose production by transiently inhibiting the respiratory enzyme chain in mitochondria. However, metformin has been associated with the rare complication of life-threatening lactic acidosis. The causation of this association is not completely clear, and acidosis is most commonly seen in patients with substantial comorbidity, but patients with markedly reduced renal function are at increased risk. Metformin is not metabolized, and 90% is excreted as the active drug by the kidneys (Spiller, 2006). Plasma metformin levels are thus substantially higher in patients with reduced creatinine clearance (Lipska, 2011). There is controversy regarding the safety of use in patients with nondialysis CKD; in the United States, the drug label warns against use of metformin when serum creatinine is greater than 1.5 mg/dL (130 $\mu\text{mol/L}$) in males or 1.4 mg/dL (124 $\mu\text{mol/L}$) in females, whereas there are studies suggesting that metformin can be used with relative safety down to a GFR of 45 mL/min. Metformin should not be used in dialysis patients.

TABLE

32.2

Agents for Diabetes Mellitus in Chronic Kidney Disease

Drug	Usual Nonuremic Dose	Dialysis Patient Dose (% of Nonuremic Dose)
Insulins		
<i>Short-acting</i>		
Regular	0.2–1 units/kg/d SC b.i.d.–q.i.d.	Decrease dose (25%–50%)
Lispro	0.2–1 units/kg/d SC b.i.d.–q.i.d.	Decrease dose (25%–50%)
Aspart	0.2–1 units/kg/d SC b.i.d.–q.i.d.	Decrease dose (not defined)
<i>Intermediate-acting</i>		
NPH	0.2–1 units/kg/d SC q24h–b.i.d.	Decrease dose (not defined)
<i>Long-acting</i>		
Glargine	0.1–1 units/kg/d SC q24h	Decrease dose (not defined)

Detemir	0.1–1 units/kg/d SC q24h	Decrease dose (not defined)
Sulfonylureas		
Glipizide	2.5–20 mg PO q24h–b.i.d.	2.5–10 mg PO q24h–b.i.d. (50%)
Glimeperide	1–8 mg PO q24h	1–4 mg PO q24h (50%)
Tolbutamide	250–3,000 mg PO q24h	Same (100%)
Glyburide	1.25–10 mg PO q24h	Avoid in renal failure
Thiazolidinediones^a		
Rosiglitazone	4–8 mg PO q24h–b.i.d.	Same (100%)
Pioglitazone	15–30 mg PO q24h	Same (100%)
α-Glucosidase inhibitors		
Acarbose	50–100 mg PO t.i.d.	Not recommended in renal failure
Miglitol	50–100 mg PO t.i.d.	Not recommended in renal failure
Meglitinides		
Repaglinide	0.5–8 mg PO t.i.d.	0.5–4 mg PO t.i.d. (50%)
Nateglinide	60–120 mg PO t.i.d.	Avoid in renal failure
Biguanides		
Metformin	850–2,550 mg PO q24h–b.i.d.	Avoid in renal failure
Amylin analogs		
Pramlintide	30–120 mcg SC q.a.c.	Same (100%). No data on dialysis patients
SGLT-2 inhibitor		
Canagliflozin	100 mg–300 mg q24h	If eGFR 45 to <60 mL/min/1.73 m ² , 100 mg Avoid if eGFR <45 mL/min/1.73 m ²
DPP-4 inhibitors		
Sitagliptin	100 mg q24h	If eGFR \geq 30 mL/min/1.73 m ² and <50 mL/min/1.73 m ² , 50 mg (50%) If eGFR <30 mL/min/1.73 m ² , 25 mg (25%)
Saxagliptin	2.5–5 mg q24h	If eGFR <50 L/min/1.73 m ² , 2.5 mg (50%)
Linagliptin	5 mg q24h	Same
Alogliptin	25 mg q24h	If eGFR \geq 30 mL/min/1.73 m ² and <50 mL/min/1.73 m ² , 12.5 mg (50%) If eGFR <30 mL/min/1.73 m ² , 6.25 mg (25%)
GLP-1 receptor agonists		
Exenatide	2 mg weekly SC Up to 10 mcg b.i.d. SC	Avoid if eGFR <30 mL/min/1.73 m ²
Liraglutide	Up to 1.8 mg q24h SC	Limited experience with advanced renal disease; caution advised

^aMay cause fluid retention in chronic kidney disease patients not on dialysis.

SC, subcutaneously; b.i.d., two times per day; q.i.d., four times per day; q24h, daily; PO, by mouth; t.i.d., three times per day; q.a.c., before meals.

3. **α -Glycosidase inhibitors.** There are two α -glucosidase inhibitors available in the United States: acarbose and miglitol. They work by competitively and reversibly inhibiting gut enzymes that mediate the intestinal breakdown of oligosaccharides into simple sugars, thereby limiting their absorption. Postprandial glucose surges are reduced without stimulation of endogenous insulin, and, thus, the risk of hypoglycemia is relatively low. Little **acarbose** is absorbed, but it is extensively metabolized in the gut, and about one-third of the metabolites, some active, are absorbed (Spiller, 2006; Reilly, 2010). In patients with reduced renal function, the plasma levels of acarbose and its metabolites can increase. **Miglitol** is absorbed to a greater extent than acarbose. Miglitol is not metabolized and is excreted unchanged in the urine (Spiller, 2006; Reilly, 2010). Neither acarbose nor miglitol has been well studied in patients in whom eGFR is less than 25 mL/min per 1.73 m², and, in general, their use is not recommended in dialysis patients.
4. **Peroxisome proliferator-activated receptor (PPAR) agonists.** PPAR- γ agonists include drugs such as rosiglitazone and pioglitazone. These drugs sensitize target tissues to insulin, increase glucose uptake in muscle and adipose tissue, and decrease hepatic glucose production. They may also have beneficial anti-inflammatory, vascular, and metabolic (hypolipidemic) effects.

Pioglitazone is metabolized primarily by the liver. It has been found to be safe and effective as monotherapy and add-on therapy to other oral antidiabetic agents in patients on HD when studied up to 96 weeks (Abe, 2010). There is no need for dose reduction. Pioglitazone has been associated with bladder cancer. In the United States, it carries a warning to avoid use in patients with active bladder cancer and to consider risks versus benefits prior to initiating therapy in patients with a history of bladder cancer.

Like pioglitazone, **rosiglitazone** is metabolized primarily by the liver. Rosiglitazone was effective at all degrees of renal function (Chapelsky, 2003). One group found an increase in interdialysis weight on rosiglitazone, but this study lacked a true control group (Chiang, 2007). There was no meaningful change in the pharmacokinetics of the drug in patients on HD, and there was no difference in plasma drug levels on dialysis compared with nondialysis days (Thompson-Culkin, 2002), suggesting no need for dosage adjustment because of altered renal function. However, in one study in patients on CAPD, the half-life of rosiglitazone was increased compared with healthy volunteers (Aramwit, 2008). In 2007, a review of a variety of sources of available data linked rosiglitazone with an increased risk of myocardial infarction and cardiovascular death, and its use has been restricted in the United States (Nissen, 2007). This restriction was partially lifted by the U.S. Food and Drug Administration (FDA) in November of 2013, but rosiglitazone remains suspended from the market in Europe and a number of other countries. Both pioglitazone and rosiglitazone have been associated with weight gain, edema, and congestive heart

failure in nonuremic patients; the mechanism is thought to be increased renal retention of sodium and water. Acute myopathy has been reported when glitazones were given in conjunction with fibrates.

5. **Meglitinides.** **Repaglinide** is a member of the meglitinide family of compounds and acts as an insulin secretagogue. It binds to the sulfonylurea receptor and functions in a manner similar to the sulfonylureas, but it has an additional β cell binding site and thus a different binding profile (Hatorp, 2002). It differs from the sulfonylureas in several ways. First, it has a much shorter duration of action with a half-life of 1–1.5 hours with somewhat less hypoglycemic risk than SUs. Second, it is eliminated almost entirely by hepatic metabolism with biliary or fecal excretion of mainly inactive metabolites. Only 8% is excreted in urine. Like SUs, it is highly protein bound. Several studies have examined the impact of renal disease on repaglinide pharmacokinetics (Marbury, 2000; Schumacher, 2001; Hatorp, 2002). In general, there is no impact with moderate renal disease. However, with more severe renal disease (GFR < 30 mL/min), the “area under the curve” of the plasma level of the drug was higher because of increased elimination half life. Despite these findings, there was little difference in hypoglycemia, and repaglinide is not contraindicated in people with renal disease but should be used with caution, starting at a low dose (0.5 mg) and titrating upward slowly. Studies were not conducted in patients with eGFR <20 mL/min per 1.73 m² or in patients with renal failure requiring dialysis. Like the SUs, it may not be effective if the individual being treated can no longer generate endogenous insulin.

In contrast to repaglinide, which has primarily fecal excretion, **nateglinide**, another meglitinide, is 90% excreted by the kidney, primarily as active metabolites (Spiller, 2006; Reilly, 2010). Use of nateglinide in patients on dialysis should thus be avoided or done with the greatest caution.

6. **Glucagon-like peptide-1 (GLP-1) receptor agonists.** There are two glucagon-like peptide-1 (GLP-1) receptor agonists available, exenatide (which comes in both twice-per-day and once-per-week formulations) and liraglutide. **GLP-1** is a naturally occurring gut peptide made and secreted by colonic L-cells in response to meals. It has multiple actions, including stimulation of endogenous insulin secretion, inhibition of endogenous glucagon secretion, delay of gastric emptying, and inhibition of appetite. The effects on insulin and glucagon are glucose-dependent, that is, they occur only in the presence of hyperglycemia. These actions result in improved glucose control with little hypoglycemic risk (as monotherapy) and weight loss. GLP-1 is rapidly degraded by dipeptidyl peptidase 4 (DPP-4). However, both exenatide and liraglutide are degradation-resistant and undergo little systemic metabolism.

Exenatide is excreted mainly by the kidneys. The half-life increases with decreasing renal function. Exenatide was generally well tolerated in the mild and moderate renal insufficiency without dose adjustment, but not in subjects with ESKD due to nausea and vomiting (Linnebjerg, 2007). Its use is not recommended for those with eGFR <30 mL/min per 1.73 m². Caution is also advised for people who have received kidney transplants. Exenatide caused an increased incidence in thyroid C-cell tumors at clinically relevant exposures in rats compared with controls. It is unknown whether it causes thyroid C-cell tumors in humans, including medullary thyroid

carcinoma; nonetheless, it is contraindicated in patients with a personal or family history of medullary thyroid carcinoma and in patients with multiple endocrine neoplasia syndrome type 2. Pancreatitis has been identified in postmarketing studies as a possible adverse consequence of exenatide use.

In contrast to exenatide, only about 6% of **liraglutide** (as metabolites) is excreted by the kidneys; the pharmacokinetics of the drug is little altered by kidney disease (Jacobsen, 2009). However, there is increased incidence of nausea in those with eGFR <60 mL/min per 1.73 m², though the number of people studied was small (Davidson, 2011). No dose adjustment is required in US labeling, but it should be used with caution in people with advanced kidney impairment because of limited experience. Liraglutide carries the same warnings as exenatide with regard to medullary thyroid cancer, multiple endocrine neoplasia syndrome type 2, and pancreatitis.

7. **Dipeptidyl peptidase-4 (DPP-4) inhibitors.** There are four DPP-4 inhibitors now available in the United States: sitagliptin, saxagliptin, linagliptin, and alogliptin. As a group, they act by inhibiting the enzyme (DPP-4), which rapidly degrades endogenous incretin hormones. The major incretin is glucagon-like peptide 1 (GLP-1), a gut hormone that stimulates insulin, suppresses glucagon, delays gastric emptying, and decreases appetite.

Approximately 75%–80% of an oral dose of **sitagliptin** is excreted unchanged in the urine, and sitagliptin levels markedly increase with declining renal function (Bergman, 2007). Because of this, it is recommended that the dose be adjusted on the basis of eGFR. A 100-mg daily dose can be given if eGFR is >50 mL/min per 1.73 m². This dose should be reduced to 50 mg if eGFR falls below 50 mL/min per 1.73 m², and to 25 mg daily if eGFR is below 30 mL/min per 1.73 m² or if the patient is on dialysis (Arjona Ferreira, 2013). At these reduced doses, sitagliptin was similarly effective in improving glycemic control as glipizide with less severe hypoglycemia (0% vs. 7.7%) in patients on dialysis. These findings confirm an earlier study in which hypoglycemia was much less common with sitagliptin (4.6% of the patients treated with sitagliptin compared with 23% of those treated with glipizide) (Chan, 2008). The fraction removed by HD is relatively small, 13% and 4%, for HD initiated 4 or 48 hours postdose, respectively, so that sitagliptin can be administered without regard to the timing of HD (Bergman, 2007).

Saxagliptin, the second DPP-4 inhibitor to reach market, has a major active metabolite 5-hydroxy saxagliptin, which is about half as potent as the parent compound (Boulton, 2011). About 75% is excreted in the urine; 24% is saxagliptin and 36% is 5-hydroxy saxagliptin and minor metabolites. Levels of saxagliptin and 5-hydroxy saxagliptin rise with the degree of renal impairment with the metabolite rising to a greater degree than saxagliptin itself. Because of this, a dosage adjustment is advised. A full 5-mg dose of saxagliptin can be used if eGFR is greater than 50 mL/min per 1.73 m² but dose should be reduced to 2.5 mg daily for lower eGFR. Interestingly, in patients on HD, saxagliptin concentrations are slightly lower than in healthy subjects, but 5-hydroxy saxagliptin is much higher. It has been speculated that this may be due to

the efficient removal of saxagliptin by HD. Because 4 hours of HD removes about 23% of saxagliptin, it should be given after dialysis sessions. Saxagliptin was superior to placebo in improving glycemic control in those with moderate or severe renal insufficiency, but saxagliptin was no better than placebo in those with ESKD (Nowicki, 2011). The percentage of patients with hypoglycemic events was similar between those treated with saxagliptin (28%) and those treated with placebo (29%) (Nowicki, 2011).

The elimination of the third available DPP-4 inhibitor, **linagliptin**, is not dependent on the kidney. Renal excretion of unchanged linagliptin is less than 7%, and the degree of renal impairment does not affect linagliptin concentrations. Its 5-mg daily dose does not need to be adjusted in renal disease (Graefe-Mody, 2011). However, experience in people with advanced renal disease is limited

About 10%–20% of **alogliptin** is metabolized by the liver to compounds with little pharmacological activity. Approximately 63% is excreted unchanged by the kidney. Alogliptin doses should be reduced by one-half of the standard dose (to 12.5 mg/day) for patients with eGFR between 30 and 50 mL/min per 1.73 m², and by three-quarters (to 6.25 mg/day) in those with eGFR < 30 mL/min per 1.73 m² or ESKD requiring HD (Golightly, 2012).

Safety concerns have been raised with the incretin category of antidiabetic agents relating to a pancreatic safety signal associated with incretin-based medications. The U.S. FDA and the European Medicines Agency (EMA) working in parallel reviewed nonclinical toxicology studies, clinical trial data, and epidemiologic data relating to these medications. Both agencies agreed and published that assertions concerning a causal association between incretin-based medications and pancreatitis or pancreatic cancer were inconsistent with their review (Egan, 2014).

8. **Sodium glucose co-transporter 2 inhibitor.** Canagliflozin and dapagliflozin are sodium glucose co-transporter 2 inhibitors. These medications lower the renal threshold for glucose, cause an osmotic diuresis by increasing urinary glucose excretion, and thereby decrease plasma glucose in hyperglycemic patients. Because of their urine-dependent mechanism of action, these medications are not effective in patients with severe renal impairment.
9. **Pramlintide.** Pramlintide is a synthetic analog of human amylin. Amylin is a naturally occurring hormone synthesized by pancreatic β cells that is co-secreted with insulin in response to food intake. Pramlintide, like amylin, prevents the postprandial rise in glucagon and increases satiety, thus decreasing caloric intake. Pramlintide also slows gastric emptying. It is metabolized mainly by the kidneys to an active metabolite. There is no need for dosage adjustment in patients with renal impairment down to an eGFR of 20 mL/min per 1.73 m². There are few or no data on its use in patients on dialysis.

V. **HYPERKALEMIA.** Hyperkalemia occurs commonly in diabetic patients treated by maintenance HD. The causal factors include insulin deficiency and resistance (resulting in impaired potassium uptake by cells), aldosterone deficiency (resulting in impaired colonic and residual renal excretion), metabolic acidosis (resulting in increased proton–potassium exchange across cells), administration of other drugs that can cause hyperkalemia, intracellular to extracellular

fluid shifts due to hyperglycemia (resulting in movement of water accompanied by potassium out of cells), and excesses in dietary potassium intake. Severe hyperkalemia is much less frequently found in diabetic patients on maintenance PD. Treatment in diabetic patients generally does not differ from that in the general dialysis population, and is discussed in Chapters 10 and 11.

VI. CARDIOVASCULAR DISEASE AND HYPERTENSION

- A. **Hypertension.** The incidence of hypertension is high in diabetic dialysis patients. Control of high blood pressure is very important for the prevention of cardiovascular sequelae and deterioration of vision. Most diabetics have volume-sensitive hypertension that can be controlled by appropriate sodium and fluid restriction and by removal of excess extracellular fluid by dialysis. The treatment of hypertension in diabetic dialysis patients is similar to that for all such patients, and is discussed in detail in Chapter 33.
- B. **Coronary artery disease.** Despite the increased prevalence of diabetic patients, outcomes of coronary artery bypass grafting have continuously improved in dialysis patients. Nonetheless, mortality rates remain almost threefold higher compared with non-ESKD patients (Parikh, 2010). See Chapter 38.
- C. **Peripheral vascular disease.** Diabetic patients on dialysis have a very high rate of amputation (O'Hare, 2003). Frequent examination of the feet by a podiatrist is important; with regular care focused on prevention of ulcer development, the risk of amputation can be minimized.

VII. **CEREBROVASCULAR DISEASE.** The incidence of stroke is higher in diabetic dialysis patients than in their nondiabetic counterparts. Although the use of aspirin has been shown to reduce the risk of stroke in nonuremic patients, the benefit of such therapy in diabetic dialysis patients is unknown, and the use of aspirin theoretically increases the risk of intraocular hemorrhage. Coumarin anticoagulants also increase bleeding risk in this population more than in nonuremic diabetic patients and are associated with additional risks of vascular calcification and calciphylaxis.

VIII. EYE PROBLEMS IN DIABETICS ON DIALYSIS

- A. **Diabetic retinopathy.** Retinopathy is present in almost all type 1 diabetic patients with ESKD. In such patients, another cause of kidney disease should be sought if the retinal examination (including fluorescein angiography) is normal. The situation in type 2 diabetic patients is not as clear. In one study, diabetic retinopathy was present in only 15 of 27 patients (56%) with biopsy-proven diabetic glomerulosclerosis (Parving, 1992). In another biopsy study, a close correlation was observed between the presence of severe retinopathy and Kimmelsteil–Wilson nodules on biopsy, whereas those without retinopathy had mesangial sclerosis but not nodular sclerosis. Thus, the presence of retinopathy appears to increase the likelihood of more severe renal lesions (Schwartz, 1998).

Hypertension, which is also present in the majority of dialysis patients, accelerates progression of diabetic retinopathy, and may by itself, cause retinal and vitreous hemorrhage. Vascular events secondary to hypertensive retinopathy (branch retinal vein occlusion from obstruction at the site of arteriovenous crossings) can cause sudden decreases in vision. Control of hypertension may prevent this complication, as well as the more rare central retinal vein and artery occlusion.

Retinopathy ultimately progresses to a proliferative stage believed to be secondary to local hypoxia and characterized by intense proliferation of new blood vessels in the retina. These vessels, which are located in the surface layer of the retina, cause loss of vision through vitreous bleeding, and by causing macular distortion or detachment. Discovery of proliferative retinopathy is an indication for laser treatment, which decreases the risk of detachment and the need for oxygen (by destroying nonessential parts of the retina). Vitreous hemorrhages from proliferative retinopathy obstruct the path of light and may lead to retinal detachment and blindness. Vitrectomy and other microsurgical techniques (removal of retinal membranes, reattachment of retina) can improve vision in one-third to one-half of patients. Evidence is accumulating for a role for inhibitors of vascular endothelial growth factor (VEGF) in this condition (Osaadon, 2014). Active collaboration with an ophthalmologist skilled in laser photocoagulation is necessary. Most diabetic patients with ESKD have retinopathy by the time dialysis is initiated. Additional laser therapy and regular screening for glaucoma are vital components of comprehensive care for diabetic dialysis patients.

B. **Other eye problems.** Diabetic patients on dialysis are subject to other eye complications common to all patients on dialysis. **Conjunctivitis and keratitis** are treated with ophthalmic preparations of antibiotic, antifungal, or antiviral agents in the usual doses. The dose of antibiotics given systematically should be adjusted for dialysis. **Band keratopathy** (corneal–conjunctival calcification) may afflict both diabetic and nondiabetic dialysis patients who have uncontrolled hyperphosphatemia. A “**red-eye syndrome**” due to irritation of the conjunctiva by calcium phosphate deposits may complicate band keratopathy. Superficial keratectomy or chelation of the calcium deposits with local application of ethylenediamine tetraacetic acid (EDTA) has been used to treat refractory cases. **Glaucoma and cataracts** in dialysis patients are treated in the same way as in the general population. Proactive eye surveillance and intervention have been effective in sustaining at least ambulatory vision in nearly all diabetic dialysis patients.

IX. **IMPOTENCE.** Impotence is common in diabetic dialysis patients. Autonomic neuropathy and peripheral vascular disease associated with diabetes are operative, as are the usual uremic causes.

X. **REFERRAL FOR TRANSPLANTATION.** In diabetic patients in whom no contraindication to transplantation exists, renal transplantation is the preferred method of managing ESKD because of improved survival with transplantation (approximately 80% 3-year survival vs. 50% 3-year survival in patients maintained on dialysis). Among predialysis diabetic patients with chronic kidney disease who are eligible for transplantation, preemptive kidney transplantation is preferred to initiation of dialysis followed by transplantation. Living donor kidneys are preferred to deceased donor kidneys. Use of extended donor kidneys can increase the number of diabetic dialysis patients undergoing successful transplantation. Screening coronary angiography may be necessary as part of the pretransplant workup; screening dobutamine stress echocardiography, if negative, may be sufficient in some patients (especially those not yet on dialysis, in whom there is a risk of contrast nephropathy).

- XI. **BONE DISEASE.** Adynamic bone disease is common among diabetic patients with ESKD (see Chapter 36).
- XII. **ANEMIA.** The response to erythropoietin is satisfactory for anemic diabetics treated with either HD or PD (see Chapter 34).
- XIII. **CONCLUSION.** The care of diabetic patients with ESKD is a demanding task. In addition to members of the dialysis team, representatives of other specialties (e.g., vascular surgery, podiatry, ophthalmology, neurology, transplantation surgery) are needed. The existence of a diabetic team, with all of the subspecialties available, working under the coordination of a nephrologist and a nurse-specialist in diabetes is highly desirable to provide the best care for this population.

References and Suggested Readings

- Abe M, et al. Clinical effectiveness and safety evaluation of long-term pioglitazone treatment for erythropoietin responsiveness and insulin resistance in type 2 diabetic patients on hemodialysis. *Expert Opin Pharmacother*. 2010;11:1611–1620.
- Adamis AP, et al. Changes in retinal neovascularization after pegaptanib (Macugen) therapy in diabetic individuals. *Ophthalmology*. 2006;113:23–28.
- Agrawal A, Sautter M, Jones N. Effects of rosiglitazone maleate when added to a sulfonylurea regimen in patients with type 2 diabetes mellitus and mild to moderate renal impairment: a post hoc analysis. *Clin Therap*. 2003;25:2754–2764.
- Al-Kudsi RR, et al. Extreme hyperglycemia in dialysis patients. *Clin Nephrol*. 1982;17:228–231.
- Aramwit P, Supasyndh O, Sriboonruang T. Pharmacokinetics of single-dose rosiglitazone in chronic ambulatory peritoneal dialysis patients. *J Clin Pharm Therap*. 2008;33:685–690.
- Arjona Ferreira JC, et al. Efficacy and safety of sitagliptin in patients with type 2 diabetes and ESRD receiving dialysis: a 54-week randomized trial. *Am J Kidney Dis*. 2013;61:579–587.
- Arora SK, McFarlane SI. The case for low carbohydrate diets in diabetes management. *Nutr Metab (Lond)*. 2005;2:16.
- Atherton G. Renal replacement and diabetes care: the role of a specialist nurse. *J Diab Nursing* 2004;8:70–72.
- Baldwin D, et al. A randomized trial of two weight-based doses of insulin glargine and glulisine in hospitalized subjects with type 2 diabetes and renal insufficiency *Diabetes Care*. 2012;35:1970–1974.
- Beardsworth SF, et al. Intraperitoneal insulin: a protocol for administration during CAPD and review of published protocols. *Perit Dial Int*. 1988;8:145
- Bergman AJ, et al. Effect of renal insufficiency on the pharmacokinetics of sitagliptin, a dipeptidyl peptidase-4 inhibitor. *Diabetes Care*. 2007;30:1862–1864.
- Boulton DW, et al. Influence of renal or hepatic impairment on the pharmacokinetics of saxagliptin. *Clin Pharmacokinet*. 2011;50: 253–265.
- Burmeister JE, Campos JF, Miltersteiner DR. Effect of different levels of glucose in the dialysate on

the risk of hypoglycaemia during hemodialysis in diabetic patients. *J Bras Nefrol.* 2012;34:323–327.

- Castellino P, et al. Glucose and amino acid metabolism in chronic renal failure: effect of insulin and amino acids. *Am J Physiol.* 1992;262:F168–F176.
- Chan JCN, et al. Safety and efficacy of sitagliptin in patients with type 2 diabetes and chronic renal insufficiency. *Diabetes Obes Metab.* 2008;10:545–555.
- Chapelsky M, et al. Pharmacokinetics of rosiglitazone in patients with varying degrees of renal insufficiency. *J Clin Pharmacol.* 2003;43:252–259.
- Charpentier G, Riveline JP, Varroud-Vial M. Management of drugs affecting blood glucose in diabetic patients with renal failure. *Diabet Metab.* 2000;26(suppl 4):73–85.
- Chiang C, et al. Rosiglitazone in diabetes control in hemodialysis patients with and without viral hepatitis infection effectiveness and side effects. *Diabetes Care.* 2007;30:3–7.
- Cooper BA, et al. The IDEAL Study: a randomized, controlled trial of early versus late initiation of dialysis. *N Engl J Med.* 2010;363:609–619.
- Czock D, et al. Pharmacokinetics and pharmacodynamics of lispro-insulin in hemodialysis patients with diabetes mellitus. *Int J Clin Pharmacol Ther.* 2003;41:492–497.
- Daniels ID, Markell MS. Blood glucose control in diabetics: II. *Semin Dial.* 1993;6:394.
- Danne T, Bolinder J. New insulins and insulin therapy. *Diabetes Care.* 2011;34:661–665.
- Dasgupta MK. Management of patients with type 2 diabetes on peritoneal dialysis. *Adv Perit Dial.* 2005;21:120–122.
- Davidson J, et al. Mild renal impairment has no effect on the efficacy and safety of liraglutide. *Endocr Pract.* 2011;17:345–355.
- DeFronzo RA, et al. Glucose intolerance in uremia. Quantification of pancreatic beta cell sensitivity to glucose and tissue sensitivity to insulin. *J Clin Invest.* 1978;62:425–435.
- Duckworth W, et al; for the VADT Investigators. The duration of diabetes affects the response to intensive glucose control in type 2 subjects: the VA Diabetes Trial. *J Diabetes Complications.* 2011;25:355–361.
- Egan AG, et al. Pancreatic safety of incretin-based drugs—FDA and EMA assessment *N Engl J Med.* 2014;370:794–797.
- Firaneck CA, Jacob DT, Sloand JA. Avoidable iatrogenic hypoglycemia in patients on peritoneal dialysis: the risks of nonspecific glucose monitoring devices and drug-device interaction. *J Patient Saf.* 2013 Sep 27.
- Flynn CT. The Iowa Lutheran protocol. *Perit Dial Bull.* 1981;1:100.
- Goldberg T, et al. Advanced glycoxidation end products in commonly consumed foods. *J Am Diet Assoc.* 2004;104:1287–1291.
- Golightly LK, Drayna CC, McDermott MT. Comparative clinical pharmacokinetics of dipeptidyl peptidase-4 inhibitors. *Clin Pharmacokinet.* 2012;5:501–514.
- Graefe-Mody U, et al. Effect of renal impairment on the pharmacokinetics of the dipeptidyl peptidase-4 inhibitor linagliptin. *Diabetes Obes Metab.* 2011;13:939–946.
- Graham GG, et al. Clinical pharmacokinetics of metformin. *Clin Pharmacokinet.* 2011;50:81–98.
- Hatorp V. Clinical pharmacokinetics and pharmacodynamics of repaglinide [Review]. *Clin Pharmacokinet.* 2002;41:471–483.
- Iglesias P, Diez JJ. Peroxisome proliferator-activated receptor gamma agonists in renal disease. *Eur*

J Endocrinol. 2006;154:613–621.

- Jackson MA, et al. Hemodialysis-induced hypoglycemia in diabetic patients. *Clin Nephrol.* 2000;54:30–34.
- Jacobsen L, et al. Effect of renal impairment on the pharmacokinetics of the GLP-1 analogue liraglutide. *Br J Clin Pharm.* 2009;68:898–905.
- K/DOQI Workgroup. K/DOQI clinical practice guidelines for cardiovascular disease in dialysis patients. *Am J Kidney Dis* 2005;45(suppl 3):S1.
- Khanna R, et al. The Toronto Western Hospital protocol. *Perit Dial Bull.* 1981;1:101.
- Legrain M, Rottembourg J. The “Pitie-Salpetriere” protocol. *Perit Dial Bull.* 1981;1:101.
- Lin CL, et al. Improvement of clinical outcomes by early nephrology referral in type II diabetics on hemodialysis. *Ren Fail.* 2003;25:455–464.
- Linnebjerg H, et al. Effect of renal impairment on the pharmacokinetics of exenatide. *Br J Clin Pharm.* 2007;64:317–327.
- Lipska KJ, Bailey CJ, Inzucchi SE. Use of metformin in the setting of mild-to-moderate renal insufficiency. *Diabetes Care.* 2011;34:1431–1437.
- List JF, et al. Sodium-glucose co-transport inhibition with dapagliflozin in type 2 diabetes mellitus. *Diabetes Care.* 2009;32:650–657.
- Little R, et al. Can glycohemoglobin be used to assess glycemic control in patients with chronic renal failure? *Clin Chem.* 2002;48:784–785.
- Locatelli F, Pozzoni P, Del Vecchio L. Renal replacement therapy in patients with diabetes and end-stage renal disease. *J Am Soc Nephrol.* 2004;(suppl 1):S25–S29.
- Marbury T, Ruckle J, Hatorp V. Pharmacokinetics of repaglinide in subjects with renal impairment. *Clin Pharmacol Therap.* 2000;67:7–15.
- Maxwell R, et al. Insulin influence on the mitogenic-induced effect of the peritoneal effluent in CAPD patients. In: Khanna R, et al., eds. *Advances in Peritoneal Dialysis.* Toronto, Canada: University of Toronto Press; 1991:161–164.
- McCormack J, Johns K, Tildesley H. Metformin’s contraindications should be contraindicated. *CMAJ.* 2005;173:502–504.
- Murphy DM, et al. Reducing hyperglycemia hospitalwide: the basal-bolus concept. *Jt Comm J Qual Patient Saf.* 2009;35:216–23.
- Nakamoto H, et al. Effect of diabetes on peritoneal function assessed by peritoneal dialysis capacity test in patients undergoing CAPD. *Am J Kidney Dis.* 2002;40:1045–1054.
- Ng JM, et al. The effect of iron and erythropoietin treatment on the A1C of patients with diabetes and chronic kidney disease. *Diabetes Care.* 2010;33:2310–2313.
- Nissen S, Wolsky K. Effect of rosiglitazone on the risk of myocardial infarction and death from cardiovascular causes. *N Eng J Med.* 2007;356:2457–2471.
- Nowicki M, et al. Long-term treatment with the dipeptidyl peptidase-4 inhibitor saxagliptin in patients with type 2 diabetes mellitus and renal impairment: a randomised controlled 52-week efficacy and safety study. *Int J Clin Pract.* 2011;65:1232–1239.
- O’Hare AM, et al. Factors associated with future amputation among patients undergoing hemodialysis: results from the Dialysis Morbidity and Mortality Study Waves 3 and 4. *Am J Kidney Dis.* 2003;41:162–170.
- Oomichi T, et al. Impact of glycemic control on survival of diabetic patients on chronic regular

hemodialysis: a 7-year observational study. *Diabetes Care*. 2006;29:1496–1500.

Osaadon P, et al. A review of anti-VEGF agents for proliferative diabetic retinopathy. *Eye (Lond)* 2014;28:510–520.

Parikh DS, et al. Perioperative outcomes among patients with end-stage renal disease following coronary artery bypass surgery in the USA. *Nephrol Dial Transplant*. 2010;25:2275–2283.

Parving HH, et al. Prevalence and causes of albuminuria in non-insulin-dependent diabetic patients. *Kidney Int*. 1992;41:758–762.

Phakdeekitcharoen B, Leelasa-nguan P. Effects of an ACE inhibitor or angiotensin receptor blocker on potassium in CAPD patients. *Am J Kidney Dis*. 2004;44:738–746.

Quellhorst E. Insulin therapy during peritoneal dialysis: pros and cons of various forms of administration. *J Am Soc Nephrol*. 2002;13(suppl 1):S92–S96.

Raimann JG, et al. Metabolic effects of dialyzate glucose in chronic hemodialysis: results from a prospective, randomized crossover trial. *Nephrol Dial Transplant*. 2012;27:1559–1568.

Reilly JB, Berns JS. Selection and dosing of medications for management of diabetes in patients with advanced kidney disease. *Semin Dial*. 2010;23:163–168.

Schomig M, et al. The diabetic foot in the dialyzed patient. *J Am Soc Nephrol*. 2000;11:1153–1159.

Schumacher S, et al. Single- and multiple-dose pharmacokinetics of repaglinide in patients with type 2 diabetes and renal impairment. *Eur J Clin Pharmacol*. 2001;52:147–152.

Schwartz MM, et al. Renal pathology patterns in type II diabetes mellitus: relationship with retinopathy. The Collaborative Study Group. *Nephrol Dial Transplant*. 1998;13:2547–52.

Shurraw S, et al. Glycemic control and the risk of death in 1,484 patients receiving maintenance hemodialysis. *Am J Kidney Dis*. 2010;55:875–884.

Sloan L, et al. Efficacy and safety of sitagliptin in patients with type 2 diabetes and ESRD receiving dialysis: a 54-week randomized trial. *Am J Kidney Dis*. 2013;61:579–587.

Snyder RW, Berns JS. Use of insulin and oral hypoglycemic medications in patients with diabetes mellitus and advanced kidney disease. *Semin Dial*. 2004;17:365–370.

Spiller HA, Sawyer TS. Toxicology of oral antidiabetic medications. *Am J Health-Syst Pharm*. 2006;63:929–938.

St Peter W, Weinhandl ED, Flessner MF. Sitagliptin—another option for managing type 2 diabetes in dialysis patients? *Am J Kidney Dis*. 2013;61:532–535.

Thompson-Culkin K, et al. Pharmacokinetics of rosiglitazone in patients with end-stage renal disease. *J Int Med Res*. 2002;30:391–399.

Tsai CY, et al. False elevation of blood glucose levels measured by GDH-PQQ-based glucometers occurs during all daily dwells in peritoneal dialysis patients using icodextrin. *Perit Dial Int*. 2010;30:329–335.

Tzamaloukas AH, Oreopoulos DG. Subcutaneous versus intraperitoneal insulin in the management of diabetics on CAPD: a review. *Adv Perit Dial*. 1991;7:81–85.

Tzamaloukas AH, et al. Serum tonicity, extracellular volume and clinical manifestations in symptomatic dialysis-associated hyperglycemia treated only with insulin. *Int J Artif Organs*. 2004;27:751–758.

Uribarri J, et al. Diet-derived advanced glycation end products are major contributors to the body's AGE pool and induce inflammation in healthy subjects [Review]. *Ann N Y Acad Sci*. 2005;1043:461–466.

- U.S. Renal Data System. *USRDS 2013 Annual Data Report: Atlas of Chronic Kidney Disease and End-Stage Renal Disease in the United States*. Bethesda, MD: National Institutes of Health, National Institute of Diabetes and Digestive and Kidney Diseases; 2013.
- Vonesh EF, et al. The differential impact of risk factors on mortality in hemodialysis and peritoneal dialysis. *Kidney Int*. 2004;66:2389–2401.
- Williams ME, et al. Glycemic control and extended hemodialysis survival in patients with diabetes mellitus: comparative results of traditional and time-dependent Cox model analyses. *Clin J Am Soc Nephrol*. 2010;5:1595–1601.
- Windus DW, et al. Prosthetic fistula survival and complications in hemodialysis patients: effects of diabetes and age. *Am J Kidney Dis*. 1992;19:448–452.
- Yale JF. Oral antihyperglycemic agents and renal disease: new agents, new concepts [Review]. *J Am Soc Nephrol*. 2005;16(suppl 1):S7–S10.
- Yale JF, et al. Efficacy and safety of canagliflozin in subjects with type 2 diabetes and chronic kidney disease. *Diabetes Obes Metab*. 2013;15:463–473.

Treatment of hypertension represents a major area of intervention for cardiovascular risk reduction in dialysis patients.

I. DEFINITION AND MEASUREMENT. Blood pressure (BP) is commonly measured across hemodialysis, but peridialytic measurements do not adequately reflect the BP burden. Indeed, measurements made immediately before dialysis overestimate the underlying average BP, and the reverse is true for postdialysis BP. Thus out-of-office BP monitoring is the preferable method for diagnosing and monitoring BP in hemodialysis patients. Both home and 24-hour ambulatory BP monitoring (ABPM) can be applied, but ABPM is rarely used in a routine chronic hemodialysis setting unless some unusual problem with BP is suspected. Estimates based on home BP are more reproducible than pre- and postdialysis BP, and associate with ABPM better than peridialytic measurements (Agarwal, 2012). Furthermore, home measurements reflect target organ (left ventricular hypertrophy [LVH]) and cardiovascular prognosis better than pre- and postdialysis measurements (Agarwal, 2009). Two daily home measurements, one in the morning and the other before the night sleep, taken the day after a midweek dialysis session, averaged over 4 weeks are considered adequate for the diagnosis of hypertension (Agarwal, 2009). The frequency of measurements should be higher when BP lability is noted. Midweek median intradialytic BP is a more sensitive indicator of the prevailing BP burden (i.e., average ABPM) than predialysis or postdialysis BP and may be applied when home measurements are not feasible (Agarwal and Light, 2010). When ABPM is done, the period of monitoring should ideally cover the whole interdialytic interval (44 hours with a 3-per-week schedule, beginning after the midweek session). Although long sessions of ABPM are generally poorly tolerated, ABPM can give some information regarding the nocturnal BP profile, which is frequently altered in dialysis patients, but effective means of correcting lack of nocturnal BP dipping in this population have not been determined.

The definition of hypertension (Table 33.1) depends on the method of measurement (average home BP: >135/85 mm Hg; ABPM: >130/80 mm Hg; midweek median intradialysis BP: >140/90 mm Hg). Average home BP >135/85 mm Hg is considered a valid threshold for the definition of hypertension in patients on both hemodialysis and peritoneal dialysis. High visit-to-visit BP variability is common in end-stage kidney disease (ESKD) patients and is a strong predictor of mortality (Rossignol, 2012). Methods of reducing BP variability in this population have not been systematically evaluated.

Definition

Hypertension in dialysis patients should be preferentially defined on the basis of home or 24h-ABPM measurements during a midweek dialysis interval. Thresholds proposed by the European Society of Hypertension and the European Society of Cardiology can be adopted for these measurements (Mancia 2013).

Home measurements: systolic BP >135 mm Hg and/or diastolic pressure >85 mm Hg

24h-ABPM measurements (midweek dialysis interval): systolic BP >130 mm Hg and/or diastolic pressure >80 mm Hg

If home or 24h-ABPM cannot be applied, hypertension can be diagnosed as **midweek median intradialysis** systolic pressure >140 and/or diastolic pressure >90 mm Hg when the patient is believed to be at “dry weight” (see text).

Drug therapy goals

Arterial pressure goals should be established individually, taking into account age, comorbid conditions, cardiac function, and neurologic status.

Treatment targets: home BP <135/85 mm Hg or 24h-ABPM <130/80 or median intradialysis BP <140/90 mm Hg.

BP, blood pressure.

II. PATHOPHYSIOLOGY

- A. **Extracellular volume expansion and sodium retention** remains the main cause of hypertension. A relationship between chronic volume expansion and mortality is well established (Wizemann, 2009). There is an association between ECF volume expansion and diastolic dysfunction in dialysis patients (Joseph, 2006), and it is not always clear to what extent volume overload is a cause rather than a marker for severe cardiac disease. Recent attention has been called to nonosmotic accumulation of sodium in the subcutaneous space and in other organs. Nonosmotic accumulation of sodium in the muscles has been found in human hypertension (Kopp, 2013), and a similar finding was documented over 30 years ago in dialysis patients (Montanari, 1978). The consequences of nonosmotic sodium accumulation in various tissues are not fully known, but elevated sodium stores may impact inflammatory and cardiac fibrotic processes via vascular endothelial growth factor C (Mallamaci, 2008; Machnik, 2010) and other mechanisms.
- B. **Inappropriately high vascular tone.** Sodium accumulation in arterial smooth muscle cells may contribute to increased vascular stiffness. Sleep apnea, a condition characterized by high sympathetic activity, is exceedingly common in dialysis patients, and associates with vasoconstriction and nocturnal hypertension. Sympathetic overactivity triggered by afferent signals originating in diseased kidneys can cause secondary activation of the renin–

angiotensin system, and this may play an important role in the high peripheral vascular resistance seen in ESKD. In fact, there are reports of BP and sympathetic activity both falling dramatically after bilateral nephrectomy (Converse, 1992) in dialysis patients, and radiofrequency ablation of renal sympathetic nerve fibers produces similar effects (Schlaich, 2013). Asymmetric dimethyl-arginine (ADMA), an endogenous inhibitor of nitric oxide synthase, is elevated in dialysis patients, and high levels associate with elevated sympathetic nervous system activity (Mallamaci, 2004).

- C. **Hypertension and left ventricular hypertrophy.** The usual reasons for treating hypertension are to reduce the risk of stroke and cardiovascular events. One popular surrogate outcome for cardiovascular events and mortality is the presence of left ventricular hypertrophy, and many studies looking at reduction of fluid overload and/or antihypertensive treatment of dialysis patients have focused on change in left ventricular mass. It is important to realize that substantial left ventricular hypertrophy can be present in dialysis patients even at normal levels of BP (Mominadam, 2008), and that when one is optimizing extracellular fluid status, one is doing it not only to control BP, but also aiming at optimizing cardiac structure and function.

III. TREATMENT

A. **Prevention**

1. **Sodium and fluid restriction.** Most fluid intake is driven by salt ingestion, and nutritional recommendations are discussed in Chapter 31. Patients should be encouraged to restrict sodium chloride ingestion to 5 g per day (2 g or 87 mmol sodium). Another source of sodium is diffusive gain from dialysis solution when the dialysate sodium is greater than the predialysis plasma level. Many units tend to use the same dialysate sodium level for all dialysis patients, regardless of their predialysis sodium, while patients' predialysis sodium levels may range from 130 to 145 mmol/L. Use of a dialysate sodium higher than that of plasma can improve hemodynamic tolerance to fluid subtraction but increases thirst and fluid intake postdialysis. This results in an increased interdialytic weight gain, which then requires a higher ultrafiltration rate during the next dialysis. Some nephrologists favor use of "sodium profiling," where, with the aid of an advanced dialysis machine, one can begin the dialysis session with a sodium level higher than the patient's plasma level, and then progressively reduce dialysate sodium during the treatment, so that dialysis ends it with a dialysate sodium below the initial plasma level. Sodium profiling can offer some of the benefits of higher sodium dialysis in terms of hemodynamic stability while minimizing the interdialytic weight gain effect, but only if the time-averaged dialysate sodium level during the session does not exceed the initial plasma level.

Preliminary data suggest that lowering dialysate sodium unitwide (from 140 to 137 mM) may reduce interdialytic weight gain as well as fluid-related hospitalization rate (Lacson, 2011).

2. **Longer and/or more frequent dialysis sessions.** These are discussed in Chapter 16. Frequent dialysis schedules and long, nocturnal dialysis may substantially improve BP control in hypertensive dialysis patients and revert LVH. Apart from frequency, increasing the

length of a dialysis session allows for a slower ultrafiltration rate, and increases the time available to finish dialysis at the desired postdialysis weight.

B. Correction of salt and fluid overload

1. **Clinical assessment of dry weight.** Ideally, a dialysis treatment should bring the patient back to a normal extracellular volume. In clinical practice, the “**dry weight**” is defined as the level below which further fluid removal would produce hypotension, muscle cramps, nausea, and vomiting. However, the occurrence of such symptoms depends on how quickly fluid is removed, on the dialysis strategy used, on the predialysis volume status, and on concomitant drug treatment (many antihypertensive drugs impair the reflex cardiovascular adjustments to volume removal).
 - a. **Time delay in BP fall after correction of fluid overload.** There may be a time delay between lowering extracellular fluid and correction of markedly elevated BP (Charra, 1998). For this reason, if BP does not reduce initially after lowering the dry weight, this does not exclude hypervolemia as a cause of the hypertension. The lag phenomenon fits well with the hypothesis that nonosmotic sodium accumulation may occur in dialysis patients. Although it may take a considerable amount of time for this sodium to be removed from various tissue spaces (this has not been well studied), it is more likely that delayed improvement in hypertension after correction of longstanding fluid excess is due to vascular remodeling.
 - b. **Need for frequent reassessment.** Dry weight and the nutritional status should be reevaluated frequently, because loss of muscle mass due to malnutrition or to intercurrent illness can result in fluid overload. For example, when a patient returns to the dialysis unit after a hospitalization, the previously determined level of “dry weight” will almost always need to be reset to a lower level, due to intercurrent loss of lean body mass.

2. Technology

- a. **Bioimpedance analysis (BIA).** The assessment of dry weight is based on subjective clinical assessment. Tracking optimal dry weight by the usual clinical criteria (presence of edema, jugular venous distension, lung râles) may be difficult. Furthermore, edema may not be detectable until the interstitial volume has risen by about one-third above normal (e.g., about 5 L). Multifrequency bioimpedance spectroscopy has now emerged as a reliable method to measure body fluids. The Body Composition Monitor (BCM, Fresenius Medical Care, Germany) is one such device that has been well validated in dialysis patients (Moissl, 2006). The application of a BCM-based treatment policy aimed at minimizing fluid overload has been used to control hypertension in a dialysis setting (Moissl, 2013). In a randomized controlled trial, a BCM-guided fluid management approach led to clear-cut improvement in left ventricular mass index and vascular stiffness (Hur, 2013). However, no evidence has been produced so far that use of BCM-guided “dry weight” increases survival or reduces fluid-related hospitalization.
- b. **Other methods.** Continuous recording of hematocrit during dialysis (Crit-line Monitor) is considered a useful method, but a clinical trial testing the hypothesis that the systematic use of this device would improve clinical outcomes found

higher, rather than lower, nonvascular and vascular access–related hospitalizations and mortality as compared with conventional monitoring (Reddan, 2005). Ultrasonography of the inferior vena cava diameter or the measurement of the diameter of the left atrium are both sensitive to volume changes but do not reflect interdialytic BP (Agarwal, 2011) and are therefore of limited value for assessing dry weight. Serum levels of brain natriuretic peptide (BNP) largely reflect left ventricular mass (Zoccali, 2001) and are unsuitable for volume monitoring (Agarwal, 2013). Pulmonary congestion can be detected and monitored by an easy to apply, reliable ultrasound technique that can be performed with virtually all ultrasound machines and probes (Mallamaci, 2010). Lung congestion is a strong predictor of death and cardiovascular events (Zoccali, 2013). Use of lung ultrasonography to help establish dry weight in dialysis patients with heart disease is attractive in theory, but its ability to improve hard outcomes such as hospitalization or mortality has not been tested.

C. Common clinical problems

1. **Excessive ultrafiltration.** Overzealous ultrafiltration may precipitate severe hypotension and disastrous cardiovascular consequences such as myocardial or cerebral infarction and mesenteric ischemia. Frequent intradialytic hypotensive episodes are associated with increased mortality, although it is not clear whether this association is causal in nature (Shoji, 2004). Intradialytic hypotension is also associated with “myocardial stunning” (manifesting as cardiac wall motion abnormalities) and with subtle ischemic changes to brain white matter linked to mood and cognition (Selby, 2014). Intensification of ultrafiltration without markedly prolonging dialysis time improves hypertension control, but increases hospitalizations for cardiovascular complications, and also increases the risk of arteriovenous fistula clotting (Curatola, 2011). It is possible that the incidence of falls may be increased. Rapid ultrafiltration rates increase the risk of dialysis hypotension, and in one observational study, ultrafiltration rates greater than 12.4 mL/kg per hour were associated with increased mortality (Movilli, 2007). Methods of minimizing the risk of intradialytic hypotension are discussed in Chapter 12. Another issue with reduction of extracellular fluid volume in both hemo- and peritoneal dialysis patients is an associated fall in residual urine volume. This urine volume is important in avoiding spikes in extracellular fluid volume, as well as for associated removal of phosphorus, higher weight middle molecules, and protein-bound uremic toxins. In patients with substantial residual urine output, it is not clear to what extent it is possible to achieve optimum levels of extracellular fluid volume while still maintaining residual kidney function. It may be that the loss of residual kidney function in such circumstances is an unavoidable price that must be paid.
2. **Intradialysis and end-dialysis hypertension** can occur in about 15% of dialysis patients and have been associated with a higher death risk (Inrig, 2009). This disturbance is multifactorial and may reflect subclinical volume overload. Sympathetic and renin–angiotensin overactivity as well as endothelial dysfunction also have been linked to this condition. At the present time, it is not clear how to treat this; anecdotally,

lowering the target dry weight has worked in some patients, but it is by no means clear that such patients are uniformly fluid-overloaded.

3. **Recurrent hypertension.** If hypertension recurs in a patient after being well controlled by volume subtraction, the most likely explanation is that the patient has returned to a state of volume excess.

D. **Antihypertensive drug use.** In patients with baseline LVH, treatment by volume subtraction is more effective in reducing LVH than BP lowering by antihypertensive drug treatment (Ozkahya, 2006). Still, a substantial number of dialysis patients receive antihypertensive drug treatment, and observational data suggest that such treatment lowers mortality overall, with most documented benefits being reported for patients taking renin–angiotensin–aldosterone system (RAAS) inhibitors or beta-blockers. The mean number of antihypertensive drugs prescribed for incident hemodialysis and peritoneal dialysis patients is 2.5 at the sixth month of dialysis treatment. Prescription patterns of these drugs vary by dialysis modality, and substantial changes in prescription patterns of beta-blockers, renin–angiotensin system antagonists, and calcium channel blockers occur from the sixth month on. Furthermore, prescription classes vary by comorbidity, race/ethnicity, and age, but little by sex (St Peter, 2013).

1. **Angiotensin-converting enzyme (ACE) inhibitors and angiotensin II receptor blockers (ARBs).** These drugs are generally well tolerated. The fact that serum plasma renin activity is overtly high in some dialysis patients and inadequately suppressed in volume-expanded patients provides a pathophysiologic rationale for use of these drugs. Because angiotensin II is strongly implicated in LVH even independently of hypertension, the use of this class of drugs would in theory be particularly useful in dialysis patients, as so many have LVH to begin with. However, randomized, placebo-controlled trials using ramipril in normotensive dialysis patients (Yu, 2006) and in patients with LVH and normal or high BP (Zannad, 2006) failed to show LVH regression. In hypertensive dialysis patients, open–label randomized trials with candesartan (Takahashi, 2006) or with various angiotensin receptor blockers (candesartan, losartan, or valsartan; Suzuki, 2008) versus placebo showed a significant risk reduction with ARBs (about 30%) for death and cardiovascular events, even though BP control in the ARB-treated patients was almost identical to that in the corresponding control arms. One large open-labeled trial with olmesartan in hypertensive dialysis patients without previous cardiovascular complications, failed to show a benefit on mortality and cardiovascular events (Iseki, 2013).

- a. **Side effects and dosing adjustments.** ACE inhibitors, by interfering with bradykinin breakdown, may be associated with an increased incidence of anaphylactoid reactions during dialysis. ACE inhibitors have been associated with hyperkalemia in patients with renal insufficiency, but can often be used in dialysis patients with minor adjustment to the potassium content of the diet, if needed. Other side effects are cough, skin rash, alteration of taste, and, rarely, agranulocytosis or angioedema. Lower angioedema and cough risk are factors in favor of ARBs. Worsening of anemia and erythropoietin resistance is another purported side effect of ACE inhibitors, an effect that depends on the accumulation of N-acetyl-seryl-

aspartyl-lysyl-proline, a physiologic inhibitor of hematopoiesis whose degradation depends on ACE. Because plasma half-life of many ACE inhibitors (or of their active metabolites) is prolonged in renal failure, reduction in dosage is often required. ARBs are extensively metabolized by the liver and do not require dose adjustment.

2. **Beta-, alpha/beta-, and alpha-adrenergic blockers.** Beta-blockers counteract the cardiovascular effects of high sympathetic activity and lower plasma renin activity (PRA) and angiotensin II, which may all participate in causing high BP in dialysis patients. Many show a documented cardioprotective effect in the setting of myocardial ischemia or infarction. High plasma noradrenaline associates with cardiovascular mortality in ESKD (Zoccali, 2002). Carvedilol, an alpha/beta-blocker, reduces morbidity and mortality in dialysis patients with systolic dysfunction (Cice, 2003). A superior cardioprotective effect of beta-blockade by atenolol over ACE inhibition by lisinopril has been recently documented in the HDPAL trial (Agarwal, 2014). In this trial of 200 dialysis patients who were randomized to receive either lisinopril or atenolol, 44-hour ambulatory BP was similarly reduced over time in the atenolol and lisinopril groups (notwithstanding a greater decrease in postdialysis body weight and an increased use of other antihypertensive agents in lisonopril-treated patients). Importantly, the risk of major cardiovascular events was halved in the atenolol group as compared with the lisinopril group, to the point that the safety monitoring board for the study recommended early termination of the trial.

- a. **Side effects and dosing adjustments.** Alpha-blockers may cause postural hypotension. Prazosin has been associated with first-dose syncope, so the first dose must be administered at bedtime. Beta-adrenergic blockers have a high incidence of side effects, such as drowsiness, lethargy, and depression. Non-selective beta-blockers need to be used cautiously in patients with a tendency toward pulmonary edema or asthma and in patients already being treated with some calcium channel blockers. Beta-blockers have an adverse effect on serum lipids; they may also have an adverse effect on cell potassium uptake, tending to increase the serum potassium level. They can mask the symptoms of hypoglycemia and augment insulin-induced hypoglycemia. All may cause bradycardia and interfere with reflex tachycardia following volume depletion.

Water-soluble beta-blockers atenolol, nadolol, and bisoprolol are removed substantially by hemodialysis and should be preferentially administered postdialysis.

3. **Calcium channel blockers.** These drugs are frequently used for the treatment of volume-resistant hypertension in dialysis patients. A large meta-analysis of BP lowering drugs in patients with hypertension and/or cardiovascular disease showed that calcium antagonists are more efficacious than other main classes of antihypertensive drugs, including beta-blockers, ACE inhibitors, and angiotensin II receptor blockers in reducing the risk of stroke, and similarly effective in preventing coronary heart disease events (Law, 2009). In a randomized, double blind trial in hypertensive dialysis patients, amlodipine produced a 9-mm Hg fall in systolic pressure and did not change

diastolic pressure over a 19-month follow-up. Amlodipine treatment in this trial was associated with a 47% decrease in the combined secondary end point (mortality from any cause or cardiovascular event), while the risk reduction (~35%) for mortality (primary end point) failed to achieve statistical significance (Tepel, 2008).

- a. **Side effects and dosing adjustments.** Verapamil can cause cardiac conduction problems, bradycardia, and constipation. Calcium channel blockers should be used very cautiously in combination with beta-adrenergic blockers, because congestive heart failure can be precipitated. Other side effects are ankle edema, headache, flushing, palpitations, and hypotension. Long-acting preparations should be used. Calcium channel blockers are excreted primarily by the liver, their pharmacokinetic profile is unaltered in chronic renal failure and by dialysis (Table 33.2), and their dosage does not require any adjustment.
4. **Sympatholytic drugs** (e.g., methyldopa, clonidine, guanabenz). As noted above, there appears to be increased tonic sympathetic activity in dialysis patients, so use of central sympatholytic drugs, which inhibit sympathetic outflow by stimulating alpha-adrenoreceptors in the brain stem, is theoretically attractive. One side benefit of clonidine is its usefulness in the treatment of diarrhea due to autonomic neuropathy. Moreover, methyldopa and clonidine are relatively inexpensive—often an important consideration. Moxonidine added to other antihypertensive drugs was well tolerated in one study of patients with advanced renal failure, and was comparable to nitrendipine in terms of efficacy (Vonend, 2003). A low, nonhypotensive dose of this drug produces a sustained reduction in directly recorded sympathetic activity in dialysis patients (Hausberg, 2010).
 - a. **Side effects and dosing adjustments.** This class of drugs does have side effects. For clonidine these include sedation, dry mouth, depression, and postural hypotension. The last may be a particular problem in diabetic patients. Clonidine may cause rebound hypertension if it is abruptly withdrawn. Such side effects are substantially reduced with the transdermal formulation. Guanabenz and guanfacine are less likely to cause rebound hypertension but are more expensive. A large clinical trial of moxonidine in heart failure, MOXCON, was stopped because of excessive deaths in the moxonidine group (Cohn, 2003), which contrasts with the beneficial effect of beta-blockers in the same condition. The use of this drug in dialysis patients with heart failure is therefore unwarranted. Methyldopa may cause hepatotoxicity or a positive direct or indirect Coombs test, interfering with cross-matching of blood. Methyldopa, clonidine, and guanfacine are excreted substantially by the kidneys, and dosage reductions may be required. Methyldopa is removed by hemodialysis to a substantial extent. Guanabenz is metabolized by the liver and requires no dosage adjustment in renal failure.

Drug	Tablet Size (mg)	Initial Dose in Dialysis Patients (mg)	Maintenance Dose Dialysis Patients (mg)	Removal During Hemodialysis
Ca antagonists				
Amlodipine	5	5 q24h	5 q24h	No
Diltiazem extended release	120, 180, 240, 300, 360	120 q24h	120–300 q24h	No
Felodipine	5, 10	5 q24h	5–10 q24h	No
Isradipine	5	5 q24h	5–10 q24h	No
Nicardipine (slow release)	30	30 b.i.d.	30–60 b.i.d.	No
Nifedipine XL	30, 60	30 q24h	30–60 q24h	No
Verapamil	40, 80, 120	40 b.i.d.	40–120 b.i.d.	No
ACE inhibitors				
Captopril	25, 50	12.5 q24h	25–50 q24h	Yes ^a
Benazepril	5, 10, 20, 40	5 q24h	5–20 q24h	Yes ^a
Enalapril	2.5, 5, 10, 20	2.5 q24h or q48h	2.5–10 q24h or q48h	Yes ^a
Fosinopril	10, 20	10 q24h	10–20 q24h	Yes ^a
Lisinopril	5, 10, 20, 40	2.5 q24h or q48h	2.5–10 q24h or q48h	Yes ^a
Perindopril	4	2 q48h	2 q48h	Yes ^a
Quinapril	5, 10, 20, 40	2.5 q24h	10–20 q24h	No
Ramipril	1.25, 2.5, 5, 10	2.5–5 q24h	2.5–10 q24h	Yes ^a
Beta-blockers				
Acebutolol	200, 400	200 q24h	200–300 q24h	Yes ^a
Atenolol	50, 100	25 q48h	25–50 q48h	Yes ^a
Bisoprolol	2.5	2.5 q24h	2.5 q24h	Yes ^a
Carvedilol	5	5 q24h	5 q24h	Yes ^a
Metoprolol	50, 100	50 b.i.d.	50–100 b.i.d.	Yes ^a
Nadolol	20, 40, 80, 120, 160	40 q48h	40–120 q48h	Yes ^a
Pindolol	5, 10	5 b.i.d.	5–30 b.i.d.	Yes ^a
Propranolol	10, 40, 80	40 b.i.d.	40–80 b.i.d.	Yes ^a
Adrenergic modulators				
Clonidine	0.1, 0.2, 0.3, TTS 0.2	0.1 b.i.d.	0.1–0.3 b.i.d., TTS weekly	No

Guanabenz	4, 8	4 b.i.d.	4–8 b.i.d.	No
Guanfacine	1, 2	1 q48h	1–2 q24h	No
Labetalol	100, 200, 300	200 b.i.d.	200–400 b.i.d.	No
Prazosin	1, 2, 5	1 b.i.d.	1–10 b.i.d.	No
Terazosin	1, 2, 5	1 b.i.d.	1–10 b.i.d.	No
Vasodilators				
Hydralazine	10, 25, 50, 100	25 b.i.d.	50 b.i.d.	No
Minoxidil	2.5, 10	2.5 b.i.d.	2.5–10 b.i.d.	Yes ^a
Angiotensin II receptor blockers				
Candesartan	4, 8, 16, 32	4 q24h	8–32 q24h	No
Eprosartan	400, 600	400 q24h	400–600 q24h	No
Irbesartan	75, 150, 300	75–150 q24h	150–300 q24h	No
Losartan	50	50 q24h	50–100 q24h	No
Telmisartan	40, 80	40 q24h	20–80 q24h	No
Valsartan	80, 160	80 q24h	80–160 q24h	No
Olmesartan	10-40	10 q24h	10-40 q24h	No

^a The dose of drugs that are removed by hemodialysis should be scheduled so that it is administered after dialysis.

None of the drugs in the table undergoes substantial removal during continuous ambulatory peritoneal dialysis.

q24h, daily; b.i.d., two times per day; q48h, every other day; ACE, angiotensin-converting enzyme; TTS, transdermal therapeutic system.

5. **Vasodilators** (e.g., hydralazine, minoxidil). These are third-line drugs. They usually require addition of a sympatholytic or beta-blocking drug because they tend to cause reflex tachycardia. Side effects of both drugs relate primarily to this reflex tachycardia and resulting palpitations, dizziness, and worsening of angina pectoris. Hydralazine is effective and inexpensive, but can cause a lupus-like syndrome at dosages of more than 200 mg per day. Because of diminished renal excretion of its active metabolite(s), the maximum allowable dosage should be reduced in dialysis patients. Minoxidil has been associated with pericarditis and is generally avoided in women because of hypertrichosis. Minoxidil is usually reserved to treat resistant hypertension.

IV. HYPERTENSIVE URGENCIES AND EMERGENCIES

- A. **Hypertensive urgency.** The term hypertensive urgency is reserved for patients who are at significant risk for a serious morbid event within a matter of days if left untreated.
 1. **Treatment.** The ideal rate of BP reduction in hypertensive urgencies is a balance between the risks of inadequate versus too-rapid lowering. In chronic hypertension, the range of cerebral autoregulation is reset upward so that patients may be less able to compensate for a sudden fall in BP, which may precipitate cerebral infarction and blindness. For this reason, abrupt forms of therapy should be avoided. The short-acting formulation of nifedipine was used as a first-line drug for severe hypertension in the

past, but is no longer recommended, as there are now a number of reports documenting myocardial, cerebral, and retinal ischemia after its use. The long-acting preparation of nifedipine or other long-acting calcium antagonist, or clonidine, should be used instead as first-line therapy. If the patient is already on treatment with such drugs, a beta-blocker, an ACE inhibitor, or a combination thereof could be added. If oral therapy fails, parenteral drugs should be used (see below).

- B. **Hypertensive emergencies** are defined as increases in arterial pressure that, if sustained *for a few hours*, would cause irreversible organ damage. Hypertensive encephalopathy, hypertensive left ventricular failure, hypertension associated with unstable angina/myocardial infarction, hypertension with aortic dissection, and cerebral hemorrhage/brain infarction are such emergencies. Hypertensive emergencies should be treated with parenteral drugs. Nitroprusside administered by continuous IV infusion (0.3–0.8 mcg/kg per minute initially to a maximum of 8 mcg/kg per minute) is particularly useful in heart failure and dissecting aneurysm but requires careful monitoring because its toxic metabolite (thiocyanate) is retained in renal failure. Cyanide levels should be monitored every 48 hours and should not exceed 10 mg/dL. The symptoms of thiocyanate toxicity are nausea, vomiting, myoclonic movements, and seizures. In general, the infusion should not be prolonged for more than 48 hours. Both nitroprusside and its metabolites are readily removed by dialysis. Intravenous labetalol may also be considered in patients without heart failure, asthma, or heart block (2 mg/min to a total of 2 mg/kg). Hydralazine 10–20 mg given slowly intravenously is a well-tried alternative, but this drug should be avoided in ischemic heart disease.

References and Suggested Readings

- Agarwal R. The controversies of diagnosing and treating hypertension among hemodialysis patients. *Semin Dial*. 2012;25:370–376.
- Agarwal R. B-type natriuretic peptide is not a volume marker among patients on hemodialysis. *Nephrol Dial Transplant*. 2013;28:3082–3089.
- Agarwal R, Light RP. Median intradialytic blood pressure can track changes evoked by probing dry-weight. *Clin J Am Soc Nephrol*. 2010;5:897–904.
- Agarwal R, et al. Home blood pressure measurements for managing hypertension in hemodialysis patients. *Am J Nephrol*. 2009;30:126–134.
- Agarwal R, et al. Inferior vena cava diameter and left atrial diameter measure volume but not dry weight. *Clin J Am Soc Nephrol*. 2011;6:1066–1072.
- Agarwal R, et al. Hypertension in hemodialysis patients treated with atenolol or lisinopril (HDPAL): a randomized controlled trial. *Nephrol Dial Transplant*. 2014;29:672–681.
- Charra B, Bergstrom J, Scribner BH. Blood pressure control in dialysis patients: importance of the lag phenomenon. *Am J Kidney Dis*. 1998;32:720–724.
- Cice G, et al. Carvedilol increases two-year survival in dialysis patients with dilated cardiomyopathy: a prospective, placebo-controlled trial. *J Am Coll Cardiol*. 2003;41:1438–1444.
- Cohn JN, et al. Adverse mortality effect of central sympathetic inhibition with sustained-release moxonidine in patients with heart failure (MOXCON). *Eur J Heart Fail*. 2003;5:659–667.

- Converse RL Jr, et al. Sympathetic overactivity in patients with chronic renal failure. *N Engl J Med*. 1992;327:1912–1918.
- Curatola G, et al. Ultrafiltration intensification in hemodialysis patients improves hypertension but increases AV fistula complications and cardiovascular events. *J Nephrol*. 2011;24:465–473.
- Grassi G, et al. Sympathetic nerve traffic and asymmetric dimethylarginine in chronic kidney disease. *Clin J Am Soc Nephrol*. 2011;6:2620–2627.
- Hausberg M, et al. Effects of moxonidine on sympathetic nerve activity in patients with end-stage renal disease. *J Hypertens*. 2010;28:1920–1927.
- Hur E, et al. Effect of fluid management guided by bioimpedance spectroscopy on cardiovascular parameters in hemodialysis patients: a randomized controlled trial. *Am J Kidney Dis*. 2013;61:957–965.
- Inrig JK, et al. Association of blood pressure increases during hemodialysis with 2-year mortality in incident hemodialysis patients: a secondary analysis of the Dialysis Morbidity and Mortality Wave 2 Study. *Am J Kidney Dis*. 2009;54:881–890.
- Iseki K, et al. Effects of angiotensin receptor blockade (ARB) on mortality and cardiovascular outcomes in patients with long-term haemodialysis: a randomized controlled trial. *Nephrol Dial Transplant*. 2013;28:1579–1589.
- Joseph G, et al. Extravascular lung water and peripheral volume status in hemodialysis patients with and without a history of heart failure. *ASAIO J*. 2006;52:423–429.
- Klassen PS, et al. Association between pulse pressure and mortality in patients undergoing maintenance hemodialysis. *JAMA*. 2002;287:1548–1555.
- Kopp C, et al. Na magnetic resonance imaging-determined tissue sodium in healthy subjects and hypertensive patients. *Hypertension*. 2013;61:635–640.
- Lacson EK, et al. Lower dialysate sodium impacts weight gain and fluid overload hospitalizations [abstract]. *J Am Soc Nephrol*. 2011;22:93A.
- Law MR, Morris JK, Wald NJ. Use of blood pressure lowering drugs in the prevention of cardiovascular disease: meta-analysis of 147 randomised trials in the context of expectations from prospective epidemiological studies. *BMJ*. 2009;338:b1665.
- Machnik A, et al. Mononuclear phagocyte system depletion blocks interstitial tonicity-responsive enhancer binding protein/vascular endothelial growth factor C expression and induces salt-sensitive hypertension in rats. *Hypertension*. 2010;55:755–761.
- Mallamaci F, et al. Analysis of the relationship between norepinephrine and asymmetric dimethyl arginine levels among patients with end-stage renal disease. *J Am Soc Nephrol*. 2004;15:435–441.
- Mallamaci F, et al. Vascular endothelial growth factor, left ventricular dysfunction and mortality in hemodialysis patients. *J Hypertens*. 2008;26:1875–1882.
- Mallamaci F, et al. Detection of pulmonary congestion by chest ultrasound in dialysis patients. *JACC Cardiovasc Imaging*. 2010;3:586–594.
- Mancia G, et al. 2013 ESH/ESC Guidelines for the management of arterial hypertension: the Task Force for the Management of Arterial Hypertension of the European Society of Hypertension (ESH) and of the European Society of Cardiology (ESC). *J Hypertens*. 2013;31:1281–1357.
- Moissl U, et al. Bioimpedance-guided fluid management in hemodialysis patients. *Clin J Am Soc Nephrol*. 2013;8:1575–1582.

- Moissl UM, et al. Body fluid volume determination via body composition spectroscopy in health and disease. *Physiol Meas*. 2006;27:921–933.
- Mominadam S, et al. Interdialytic blood pressure obtained by ambulatory blood pressure measurement and left ventricular structure in hypertensive hemodialysis patients. *Hemodial Int*. 2008;12:322–327.
- Montanari A, et al. Studies on cell water and electrolytes in chronic renal failure. *Clin Nephrol*. 1978;9:200–204.
- Movilli E, et al. Association between high ultrafiltration rates and mortality in uraemic patients on regular haemodialysis: a 5-year prospective observational multicenter study. *Nephrol Dial Transplant*. 2007;22:3547–3552.
- Ozkahya M, et al. Long-term survival rates in haemodialysis patients treated with strict volume control. *Nephrol Dial Transplant*. 2006;21:3506–3513.
- Reddan DN, et al. Intradialytic blood volume monitoring in ambulatory hemodialysis patients: a randomized trial. *J Am Soc Nephrol*. 2005;16:2162–2169.
- Rossignol P, et al. Visit-to-visit blood pressure variability is a strong predictor of cardiovascular events in hemodialysis: insights from FOSIDIAL. *Hypertension*. 2012;60:339–346.
- Schlaich MP, et al. Feasibility of catheter-based renal nerve ablation and effects on sympathetic nerve activity and blood pressure in patients with end-stage renal disease. *Int J Cardiol*. 2013;168:2214–2220.
- Selby NM, McIntyre CW. How is the heart best protected in chronic dialysis patients? Protecting the heart in dialysis patients—intradialytic issues. *Semin Dial*. 2014;27:332–335.
- Shoji T, et al. Hemodialysis-associated hypotension as an independent risk factor for two-year mortality in hemodialysis patients. *Kidney Int*. 2004;66:1212–1220.
- St Peter WL, et al. Patterns in blood pressure medication use in US incident dialysis patients over the first 6 months. *BMC Nephrol*. 2013;14:249.
- Suzuki H, et al. Effect of angiotensin receptor blockers on cardiovascular events in patients undergoing hemodialysis: an open-label randomized controlled trial. *Am J Kidney Dis*. 2008;52:501–506.
- Takahashi A, et al. Candesartan, an angiotensin II type-1 receptor blocker, reduces cardiovascular events in patients on chronic haemodialysis—a randomized study. *Nephrol Dial Transplant*. 2006;21:2507–2512.
- Tepel M, et al. Effect of amlodipine on cardiovascular events in hypertensive haemodialysis patients. *Nephrol Dial Transplant*. 2008;23:3605–3612.
- Vonend O, et al. Moxonidine treatment of hypertensive patients with advanced renal failure. *J Hypertens*. 2003;21:1709–1717.
- Wizemann V, et al. The mortality risk of overhydration in haemodialysis patients. *Nephrol Dial Transplant*. 2009;24:1574–1579.
- Yu WC, et al. Effect of ramipril on left ventricular mass in normotensive hemodialysis patients. *Am J Kidney Dis*. 2006;47:478–484.
- Zannad F, et al. Prevention of cardiovascular events in end-stage renal disease: results of a randomized trial of fosinopril and implications for future studies. *Kidney Int*. 2006;70:1318–1324.
- Zoccali C, et al. Cardiac natriuretic peptides are related to left ventricular mass and function and

predict mortality in dialysis patients. *J Am Soc Nephrol*. 2001;12:1508–1515.

Zoccali C, et al. Plasma norepinephrine predicts survival and incident cardiovascular events in patients with end-stage renal disease. *Circulation*. 2002;105:1354–1359.

Zoccali C, et al. Pulmonary congestion predicts cardiac events and mortality in ESRD. *J Am Soc Nephrol*. 2013;24:639–646.

I. ANEMIA

A. **Etiology.** The anemia of chronic kidney disease (CKD) is primarily due to insufficient production of the glycoprotein hormone erythropoietin (EPO). Although EPO can be produced in many of the body's tissues, EPO required for erythropoiesis generally is produced by endothelial cells in proximity to the renal tubules. As renal excretory function is lost, there is a relative decline in the production of EPO that correlates with the declining glomerular filtration rate. The severity of the resulting anemia varies, but if untreated, then hematocrit values in end-stage kidney disease (ESKD) of 18%–24% are typical. While the primacy of EPO deficiency is indisputable, other factors may play important contributory roles. Also, patients with ESKD may develop any of the other causes of anemia common in nonuremic subjects.

B. Consequences of anemia

1. **Symptoms.** The manifestations of anemia may be due both to the effects of decreased oxygen delivery to tissues and to the heart's compensatory changes. The most prominent symptoms of anemia are fatigue and dyspnea. Symptoms develop slowly, and the patient may gradually constrict his or her activities in compensation. The patient's overall sense of well-being is diminished. Other symptoms may include difficulty concentrating, dizziness, sleep disorders, cold intolerance, and headaches. The heart responds to diminished oxygen-carrying capacity of blood by attempting to maintain systemic oxygen delivery with increased cardiac output and left ventricular hypertrophy. Patients may notice worsening dyspnea and palpitations at this stage. Other problems include deranged hemostatic function, impaired immune function, and diminished cognitive and sexual function. Exacerbations of angina, claudication, and transient ischemic attacks may also be observed.
2. **Physical examination.** The primary physical examination finding of anemia is pallor, which may be best detected on the palms of the hands, the nail beds, and the oral mucosa. A systolic ejection murmur due to increased cardiac flow may be heard over the precordium.

C. Treatment

1. **Medications.** Because EPO deficiency is the primary cause of anemia in patients with CKD, agents that replace erythropoietin have a primary role in treatment. Since the last

edition of this handbook, the preferred term for these agents has changed to erythropoiesis-stimulating agents (ESA). Drugs may be erythropoietin analogs or may stimulate erythropoiesis in other ways. There are many different erythropoietin analogs commercially available in the United States and elsewhere: Epoetin alfa (Epogen, Procrit) and darbepoetin alfa (Aranesp) are currently available in the United States, and methoxy-polyethyleneglycol-epoetin beta (Mircera) is widely used in Europe and probably will be available shortly in the United States. Peginesatide (Omontys) currently is not being marketed in the United States, after a substantial number of allergic reactions occurred with its use. The cause is currently being investigated. **Epoetin alfa** is a glycoprotein that is indistinguishable from native erythropoietin. It is manufactured by recombinant DNA technology and has a molecular weight of 30,400 Da and a circulating half-life after intravenous administration of approximately 8 hours. **Darbepoetin alfa** is a synthetic analog of erythropoietin with increased carbohydrate content that increases the molecular weight by approximately 20% compared with native erythropoietin. As a result of the altered structure, the drug's pharmacokinetics are changed and the serum half-life is increased to approximately three times longer, 24 hours, compared with epoetin alfa. **Mircera** has an unusually long serum half-life of approximately 5.5 days. **Peginesatide** is a synthetic peptide attached to polyethylene glycol that mimics the structure of erythropoietin, but that has no amino acid sequence homology to EPO. Biological analogs of ESAs, so-called biosimilars, have been manufactured and are in use outside of the United States. The safety of these agents has been variable, but under careful FDA scrutiny, it is likely that biosimilar forms of EPO will become available in the United States.

One new class of ESAs currently under development acts to stabilize hypoxia inducible factor-1 (HIF). Synthesis of HIF is increased in the presence of hypoxia, and HIF acts to increase the transcription of EPO. HIF is rapidly degraded when normoxic conditions are present, and drugs that stabilize HIF result in increased endogenous erythropoietin production, even in anephric individuals. These drugs will be an important new class of ESAs if they are demonstrated to be safe and effective.

2. Benefits of anemia treatment with ESA.

- a. **Effect on outcomes.** Cross-sectional and retrospective studies have suggested that anemia in patients undergoing hemodialysis is associated with increased mortality, particularly when the hemoglobin concentration is <10 g/dL (100 g/L). Analyses of large administrative and clinical databases have shown that risk for mortality, hospitalization rate, and hospitalization days continue to decrease even at hemoglobin levels >11 g/dL (110 g/L). In contrast to these observational studies, interventional studies have not demonstrated improved outcomes following normalization of hemoglobin with ESA treatment. In fact, cardiovascular outcomes in these studies generally have been worse (see below).
- b. **Reduction in transfusion-related complications.** Prior to ESA therapy, up to 20% of patients on dialysis required frequent transfusions with attendant risk of immediate transfusion reactions, viral infection, iron overload, and immune sensitization. The rate of blood transfusion has been greatly reduced by the use of ESA therapy.

- c. **Improved quality of life and overall sense of well-being.** Various assessment tools have documented an improved quality of life and functional status in ESKD patients treated with ESA. Patients feel less fatigued and their exercise capacity increases. Symptoms that had been disabling in the pre-ESA era are now easily managed. However, the target level of hemoglobin for optimized quality of life is not completely known. Whether higher hemoglobin targets further improve quality of life is unclear. Some studies suggest that improvements may continue as hemoglobin is raised toward the normal range, while others have found no improvement in quality of life despite higher hemoglobin targets.
3. **Risks of ESA Therapy.** Several well-powered randomized controlled trials have tested the safety of ESA treatment aiming at relatively high hemoglobin targets (13–15 g/dL, or 130–150 g/L) in patients with CKD. In these studies, the comparison groups (controls) were either given ESA treatment to a lower Hgb target or, in one study, the control group received mostly placebo. Four such trials are particularly noteworthy: the Normal Hematocrit Trial (Besarab, 1998), CREATE (Drueke, 2006), CHOIR (Singh, 2006), and TREAT (Pfeffer, 2009). Only one of these four studies (Besarab, 1998) was done in dialysis patients, while the other three recruited nondialysis CKD subjects with eGFR or CrCl normalized to 1.73 m^2 in the range of 15–35 mL/min (CREATE), 15–50 (CHOIR), or 20–60 (TREAT). While results were somewhat inconsistent, there was a strong general trend toward increased cardiovascular risk, including risk of death, with ESA treatment to such high Hgb targets.

The mechanism of harm for an ESA treatment with a Hgb target $>13 \text{ g/dL}$ is unknown. The benefit versus risk of ESA treatment aiming at a lower Hgb target has not been formally studied in a randomized fashion. Post hoc analysis of these high Hgb target studies suggests that a higher achieved Hgb level per se may not be the source of increased risk. In these trials, mortality was higher in those patients receiving high doses of ESAs; however, it is not at all clear whether this association was causal. Patients requiring high doses of ESAs, or so-called ESA-resistant patients, show many markers of increased illness severity such as cachexia and increased levels of serum inflammatory markers, and ESA resistance is associated with a poor prognosis for survival. In one of the randomized trials noted above (TREAT), the risk of stroke was doubled, and the risk of cancer was also increased in the group given an ESA targeting a high Hgb level. The results of these studies prompted the FDA to include “black box” warnings in the product inserts for ESAs, and for various guideline committees to revise target Hgb levels downward, with the idea that one should use ESAs sparingly, and attempt only partial correction of anemia.

4. **Indications for ESA therapy and target hemoglobin.** ESA therapy should generally be initiated in CKD patients when the Hgb falls below 10 g/dL (100 g/L). The optimal Hgb level for a patient with ESKD is not known. The Kidney Disease: Improving Global Outcomes (KDIGO) anemia guidelines (2012) simply recommend that Hgb for dialysis patients should not exceed $>11.5 \text{ g/dL}$ (115 g/L). This recommendation is in some conflict with current FDA prescribing instructions, which recommend holding ESA dosing when the hemoglobin is $>11.0 \text{ g/dL}$ (110 g/L). A reasonable hemoglobin target for patients on

dialysis would be 9.5–11.5 g/dL (95–115 g/L).

a. **Effect of volume status on target hemoglobin.** When Hgb is assessed prior to a hemodialysis session, extracellular volume tends to be high, and so due to dilution, the Hgb level is at a relatively low value for the week. Monday/Tuesday predialysis Hgb levels are at their low point for the week and are about 0.3 g/dL (3 g/L) lower than midweek predialysis levels. Immediate postdialysis Hgb levels can be very substantially higher than predialysis values. So the time-averaged weekly Hgb value can be substantially underestimated by predialysis numbers. In patients with markedly fluctuating degrees of fluid overload, a change in predialysis Hgb may reflect a change in fluid status more than a change in red cell mass. This potential dilution issue must be kept in mind when monitoring Hgb levels and using this information to adjust ESA dose. For the same reason, a change from a 3 per week to a more frequent dialysis schedule can result in a modest increase in Hgb that is more a reflection of reduced extracellular fluid volume and sampling after a 1-day interdialytic interval rather than to an increase in red cell mass. Lastly, if one is trying to parse Hgb targets from nondialysis CKD patients to patients receiving dialysis, a Hgb target of 11 g/dL (110 g/L) in CKD may correspond to a somewhat lower predialysis target value in dialysis patients due to the dilution effect.

5. **Route of administration**

a. **Subcutaneous versus intravenous ESAs.** The subcutaneous route improves the efficiency of therapy, resulting in a reduced dosing requirement (of about 25%) for short-acting ESAs, specifically epoetin alfa. (Kaufman, 1998). When epoetin is given intravenously, its short half-life probably results in some drug never binding to erythropoietin receptors prior to clearance of epoetin from the circulation. When given subcutaneously, the serum half-life of epoetin is extended, allowing for more efficient receptor binding and a greater erythropoietic effect. Despite the dose reduction advantage of subcutaneous administration, the majority of patients undergoing hemodialysis in the United States continue to be treated via the intravenous route. The primary reason is probably discomfort with subcutaneous injections, whereas reduced dosing requirements are a benefit that does not directly accrue to the patient. ESAs with a longer serum half-life provide extended time in circulation to allow for greater opportunity for the drug to bind to erythropoietin receptors. There is probably no advantage or need for subcutaneous dosing for methoxypolyethylene glycol-epoetin beta, peginesatide or possibly even darbepoetin alfa. Intravenous administration of any of these agents would appear to be a better choice than subcutaneous injection of epoetin alfa in hemodialysis patients, to reduce patient discomfort. For patients on peritoneal dialysis, subcutaneous injections remain the dominant route of administration.

6. **Dosing**

a. **Initial dose.** Treatment with ESA should ideally be initiated, if required, in the pre-ESKD period. If treatment needs to be initiated for a patient already on dialysis, reasonable starting doses of epoetin alfa for a hemodialysis patient would be

2,000–3,000 units three times per week, and for a peritoneal dialysis patient 6,000 units once per week. A typical dose of darbepoetin alfa would be approximately 25 mcg once weekly for a hemodialysis patient or 60 mcg every 2 weeks for a patient on peritoneal dialysis. A typical dose of Mircerla would be 150 mcg given once monthly. Selection of a specific dose requires clinical judgment as to how symptomatic the patient is and the starting level of hemoglobin. An excessively rapid rise in the hemoglobin level should be avoided, as this may lead to an increased risk of worsening hypertension.

- b. **Initial response and plateau effect.** During the initiation phase of therapy, hemoglobin should be checked every 1–2 weeks, and the ESA dose adjusted as needed. It is very common during the initiation of treatment for a “plateauing” of effect to occur; either the hemoglobin stops increasing, or escalating doses of ESA are required to reach therapeutic targets. This period of blunted response is often due to the development of iron deficiency. Once the target level of hemoglobin has been reached, the hemoglobin should be checked every 2–4 weeks. During this maintenance phase of therapy, the dose of ESA should be adjusted on the basis of subsequent changes in hemoglobin (Fig. 34.1).

The patient’s responsiveness to ESA should be reassessed on a continuing basis. Most patients will be responsive, with hemoglobin values consistently >10 g/dL (100 g/L), and an epoetin dose of <5,000 units three times per week. In contrast, some patients will have or develop relative resistance to therapy. These patients need to be fully evaluated for causes of ESA hyporesponse. The responsiveness to ESA in all patients should be evaluated on an ongoing basis because the degree of responsiveness changes over time. In our experience, the development of resistance often signals the presence of iron deficiency or infection.

Data from ESA practice patterns in the United States suggest that the median weekly dose of intravenous EPO is about 7,000 units per week, and for darbepoetin this is 25 mcg per week (Coritsidis, 2014). Side effects of ESA therapy have been reported in patients getting the high doses. ESA-resistant patients are a selected group with poor outcome; however, it is possible that use of high doses of ESAs *per se* may be associated with increased side effects. Response to ESAs tends to plateau at high doses, and use of very high doses is uneconomical. For these reasons, the 2012 KDIGO guidelines recommend not generally exceeding four times the usual baseline weight-adjusted dose of EPO when managing EPO-resistant patients (KDIGO Anemia, 2012).

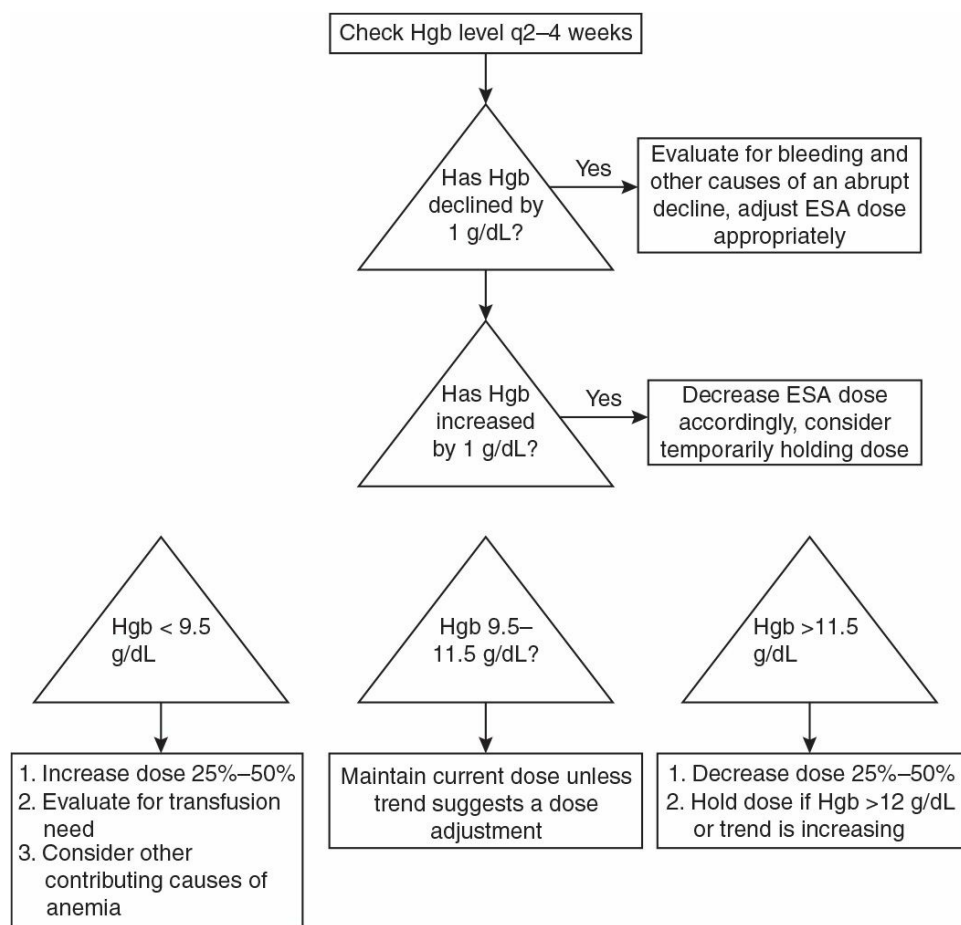

FIGURE 34.1 Flow chart for adjusting the ESA dose based on hemoglobin (Hgb) results for dialysis patients.

c. **Individualized anemia management.** The pharmacodynamics of ESA use are complicated, as the achieved Hgb levels depend not only on ESA sensitivity, but on the average lifespan of red blood cells (RBCs) in a given patient. A number of algorithms have been developed with the goal of maximizing the time that Hgb remains in a desired range. Algorithms in development may be enhanced by estimates of Hgb measured during each dialysis session by use of optical or ultrasound blood line sensors. The use of such algorithms has been reported to reduce Hgb variability as well as overall ESA dose (Lines, 2012; Gaweda, 2014).

D. **Side effects of ESA therapy.** See Section 3, above, for a discussion of cardiovascular risks of ESA therapy.

1. **Worsening of hypertension.** This is a common problem during the partial correction of anemia with ESA therapy. In some patients, there will be a need to increase antihypertensive medication doses. However, it is rare for ESA to be withdrawn because of uncontrollable hypertension. Risk factors include preexisting hypertension, a rapid increase in hemoglobin, the presence of dysfunctional native kidneys, and severe anemia prior to treatment. The cause of the hypertensive effect is incompletely understood. Factors that may contribute include the partial reversal of hypoxic vasodilation as the hemoglobin rises, reduced nitric oxide, increased cytosolic calcium levels, increased plasma endothelin levels, activation of the renin-angiotensin-aldosterone system and others. Various antihypertensives, including long-acting

calcium channel blockers, are effective for treating hypertension associated with ESA.

2. **Seizures.** These may occur in a small number of patients during periods of rapidly increasing hemoglobin in association with hypertension. The risk of seizures is small using current ESA dosing protocols.
3. **Graft clotting.** The increase in blood viscosity with higher hemoglobin values from either ESA therapy or other causes could theoretically cause increased dialyzer and arteriovenous graft clotting. Studies to date have not consistently demonstrated an increased risk of thrombosis when the hemoglobin is raised to the 11–12 g/dL (110–120 g/L) range. The impact of higher hemoglobin levels is controversial. It should be clear that some patients may experience substantial hemoconcentration during or after the hemodialysis treatment, and effects on blood viscosity and risk for access thrombosis may be a particular concern in this setting.
4. **Stroke.** The risk of stroke has been increased in some of the randomized trials of ESAs where a relatively high Hgb level has been targeted, but this was not noted in all such studies.
5. **Effect on Kt/V .** During dialysis, urea is removed from both red cells and plasma, and so urea clearance and Kt/V -urea are not affected by an increase in the Hgb. Creatinine and phosphorus are removed from the plasma only during passage of blood through the dialyzer, and as the Hgb is increased, at any given blood flow rate, the plasma flow rate and creatinine and phosphorus clearances will be proportionately reduced.

E. **ESA Treatment and Cancer.** In studies of ESA treatment for anemia related to chemotherapy or cancer, there has been some evidence to suggest that ESA treatment could reduce overall and progression-free survival. This has led to significant changes in the approach to ESA treatment in patients with cancer. Because some patients with ESKD may have either an active or past malignancy, the subject is relevant and affects treatment decisions (Hazzan, 2014).

The data, however, are not entirely consistent. For example, five published meta-analyses of published trials have not found ESA treatment to adversely impact complete responses, disease progression, or progression-free survival. However, specific studies of certain types of cancer do indicate an adverse effect, for example, in patients with head and neck cancer receiving radiotherapy. It should be noted that in studies demonstrating potential harm, ESA treatment was used to target relatively high hemoglobin levels (up to 16 g/dL in men). While the meta-analyses provide some reassurance, the adverse effects of ESAs in some studies should drive a conservative approach to treatment until the question is fully resolved.

We would suggest that for ESKD patients with a history of past malignancy, ESA therapy can be cautiously employed with hemoglobin targets as noted above for general treatment of ESKD patients. In patients with active malignancy, whether or not the patient is currently receiving chemotherapy, we would recommend a more conservative approach to treatment. This is based on an uncertainty in current knowledge on progression-free survival and increased thromboembolic risk in cancer patients. We would suggest lowering the target hemoglobin to 9–10 g/dL (90–100 g/L). For symptomatic, urgent anemia correction, blood transfusion should be employed.

F. Causes of decreased response to ESA therapy

1. **Iron deficiency.** The most important cause of a suboptimal response to ESA therapy is iron deficiency. Iron deficiency can be present at the outset of therapy, but more commonly, it develops during therapy, either due to rapid utilization of iron to support erythropoiesis or as the result of blood loss (Table 34.1).
 - a. **Blood loss.** Hemodialysis patients develop iron deficiency primarily because of chronic blood loss. Between retention of blood in the dialysis lines and filter, surgical blood loss, accidental bleeding from the access, blood sampling for laboratory testing, and occult gastrointestinal bleeding, iron losses may be substantial. Because of the overall burden of blood loss, it is very difficult to maintain iron stores in hemodialysis patients using oral iron supplements only. Losses in peritoneal dialysis patients are substantially less, and these patients can often be maintained on oral iron therapy.
 - b. **Functional iron deficiency.** In addition to a depleted iron supply, the demand for iron increases during ESA treatment, leading to a further strain on depleted iron stores. After the intravenous injection of ESA, there is an increase in the rate of erythropoiesis that leads to a greater immediate need for iron. In this setting, iron deficiency may occur even in the face of normal body iron stores. This phenomenon has been termed “functional iron deficiency.”
 - c. **Inflammation (reticuloendothelial blockade).** Occult inflammation is often present in ESKD patients. It causes an increase in serum hepcidin concentrations, which causes reduced intestinal iron absorption and diminished availability of iron in storage tissues.
 - d. **Poor absorption of dietary iron.** Iron deficiency among patients on dialysis may be exacerbated by poor absorption of dietary or medicinal iron. However, the subject is controversial, and results from studies have been conflicting.

TABLE

34.1

Causes of Iron Deficiency in Hemodialysis Patients

- Depletion of iron stores
- Chronic blood loss
 1. Blood retention by the dialysis lines and filter
 2. Blood sampling for laboratory testing
 3. Accidents related to the vascular access
 4. Surgical blood loss
 5. Occult gastrointestinal bleeding
- Decreased dietary iron absorption
 1. Phosphate binders inhibit iron absorption
 2. Histamine-2 blockers, proton-pump blockers, and functional achlorhydria impair iron absorption
 3. Uremic gut does not absorb iron optimally

- Increased iron demand

1. Due to increased rate of erythropoiesis induced by erythropoiesis-stimulating agents
 2. Impaired release of iron from storage tissues (reticuloendothelial blockade)
-

2. Diagnosis

- a. **Serum ferritin.** Ferritin is a protein used to store iron inside cells in a nontoxic form. Free iron is toxic to cells because it can generate free radicals. Although most ferritin is intracellular, some appears in the circulation and reflects iron stores, although the function of ferritin is to store iron and not to transport it in the circulation. Because serum ferritin is cleared by the liver, in hepatic insufficiency, serum levels may be markedly increased. A more common cause of increased serum ferritin is any sort of inflammation, as ferritin is an acute phase reactant. Serum ferritin levels can also be high in certain cancers and with malnutrition. If the serum ferritin level is <200 mcg/L, the likelihood of iron deficiency is quite high. However, absolute iron deficiency can be present with much higher serum ferritin levels in the presence of inflammation.
- b. **Transferrin saturation.** Transferrin is a glycoprotein that normally transports iron in the blood. In diagnosing anemia, transferrin levels are not measured directly. Instead, one can measure total iron binding capacity (TIBC) after a loading a serum sample with iron. This test measures how much iron the blood can carry in non-Hgb form, and is an indirect reflection of the transferrin level. Normal values for TIBC are 240–450 mcg/dL (43–81 mmol/L). The percent transferrin saturation (TSAT) is calculated by dividing the serum iron by the TIBC, and the value for TSAT normally is about 30% with a range of 20%–50%.
- c. **Use of serum ferritin and TSAT to diagnose cause of anemia and ESA resistance.** The serum ferritin concentration and transferrin saturation percentage (TSAT) have been the two most widely used tests of iron status for dialysis patients. However, neither test is very accurate for the assessment of iron deficiency in this patient population; the tests provide only a rough estimate of iron status. Thus, patients should not be treated intensively with intravenous iron based only on the results of these indices. The NKF's KDOQI anemia guidelines state that iron tests should be interpreted in the context of patients' clinical status, Hgb level, and ESA responsiveness. The 2012 KDIGO anemia in CKD guidelines suggest evaluating iron status (TSAT and serum ferritin) at least every 3 months during ESA therapy; however, these guidelines recommend monitoring these levels more frequently when initiating or increasing ESA dose, when there is blood loss, when monitoring response after a course of IV iron, and in other circumstances where iron stores may become depleted.

In our opinion, intensification of iron therapy for hemodialysis patients should be considered at a serum ferritin of <200 ng/mL or TSAT of $<20\%$. We would recommend maintaining TSAT $>20\%$ and serum ferritin > 100 ng/mL in peritoneal dialysis patients. Iron testing should usually be delayed for 1 week after treatment

with intravenous iron. **Functional iron deficiency** can manifest as a low TSAT with normal or elevated ferritin levels. With inflammation and **reticuloendothelial blockade**, ferritin levels are typically increased, but TSAT may be normal, as serum iron may be low, but inflammation also lowers serum transferrin, and so the TSAT is often not reduced.

- d. **Reticulocyte hemoglobin content (CHr).** This test is another test used to assess iron status and is a more direct measure of iron availability at the level of red blood cell production (Brugnara, 2003). Several studies document a good level of diagnostic accuracy and cost effectiveness, and the test shows less variability than other tests of iron status (Fishbane, 2001). When the CHr value is $<29\text{--}32$ pg/cell, patients are usually iron deficient and benefit from intravenous iron treatment.

3. Iron treatment

- a. **General principles.** Iron therapy is an integral component of anemia treatment in ESKD. Intravenous iron may be administered on an episodic basis as needed when iron deficiency develops, or by the repeated administration of small doses to maintain iron balance.
- b. **Oral iron.** Oral iron preparations are safe and relatively inexpensive. However, these supplements are associated with poor efficacy and troublesome side effects, such as constipation, dyspepsia, bloating, or diarrhea. Three randomized trials have compared oral iron with either placebo or no iron treatment in hemodialysis patients; none of the three was able to demonstrate any efficacy for oral iron. Therefore, oral iron should not be used for most hemodialysis patients.

For patients on peritoneal dialysis, oral iron is much more convenient than intravenous iron. Since these patients experience less chronic blood loss, oral iron may be sufficient to maintain iron stores. Intravenous iron therapy should be used in peritoneal dialysis patients when resistance to ESA is present and the serum ferritin is <100 ng/mL and the TSAT is $<20\%$.

- 1) **Dosage and administration.** Oral iron usually is given as ferrous sulfate, fumarate, or gluconate, in a dosage of 200 mg of elemental iron per day. The timing of the iron dose is important; ideally, iron should be taken on an empty stomach to optimize efficacy. The primary sites of iron absorption are the duodenum and proximal jejunum, and gastrointestinal symptoms are proportional to the amount of elemental iron presented to the duodenum at a single time; reduction of symptomatology may require changing the oral preparation, using pediatric dosages at more frequent intervals, or even taking the iron dosage with food. Others have suggested giving the medication during dialysis sessions (e.g., at the beginning and the end of the session) to help ensure patient compliance. Yet another strategy is to give oral iron only at bedtime. A common problem with oral iron is constipation, which can be partially managed, if necessary, with stool softeners or laxatives. Some iron preparations contain small doses of ascorbic acid to enhance iron absorption, but the advantage of the added vitamin is not established. Phosphorus binders, antacids, histamine-2 antagonists, and proton-pump inhibitors may all inhibit the absorption of oral

iron supplements. On the other hand, some novel phosphorus binders such as ferric citrate contain iron, and their use serves not only to reduce serum phosphorus in dialysis patients, but also to supply measurable amounts of iron via the gastrointestinal tract with lower requirements for IV iron and ESA (Umanath, 2013).

- c. **Intravenous iron.** Four preparations are available in the United States: Iron dextran, ferric gluconate, ferumoxytol, and iron sucrose. Intravenous iron therapy has superior availability and efficacy when compared with oral iron therapy. In hemodialysis patients, the target hemoglobin level is difficult to achieve without intravenous iron treatment. As a result, most hemodialysis patients will require intravenous iron on a regular basis. In contrast, intravenous therapy costs more, and its safety profile is less clear than that of oral iron. There are two commonly used intravenous iron dosing strategies. One is to treat established iron deficiency with a repletive 1,000-mg dose administered over 8–10 consecutive hemodialysis treatments. Alternatively, since iron deficiency occurs so frequently in hemodialysis patients, a weekly maintenance dose of 25–100 mg may be used. A recent observational study found the repletion method to have greater efficacy compared with maintenance dosing (Kshirsagar, 2013a), while not obviously increasing the risk for cardiovascular events (Kshirsagar, 2013b). However, a repletion strategy may have a greater infection risk compared with bolus therapy (Brookhart, 2013). When intravenous iron is required for peritoneal dialysis patients, infusions of 250 mg of iron may be administered over 1–2 hours.
- 1) **Intravenous iron safety: General considerations.** The most important issue to understand about the safety of intravenous iron is that it has not been well studied. There have been no studies of sufficient size and duration. Because of iron's oxidizing properties, direct injection of iron into the circulation has important potential safety implications. Without adequate study data, it is difficult to balance the benefits or risks of intravenous iron.
 - 2) **Intravenous iron safety: Anaphylaxis.** The best understood complication of intravenous iron treatment is the rare occurrence of anaphylactoid-type reactions. These are characterized by the abrupt occurrence of hypotension, dyspnea, flushing, and back pain. With iron dextran, the rate has been estimated as 0.7% of patients treated. Such reactions are less frequently observed, and tend to be of milder intensity with the nondextran forms of iron.
 - 3) **Intravenous iron safety: Infection.** Iron is a vital growth factor for microorganisms, and intravenous iron treatment has the potential to make iron more readily available to these pathogens. In addition, in vitro studies suggest that iron treatment may interfere with phagocytic function of white blood cells. Early retrospective studies found higher serum ferritin levels in hemodialysis patients to be associated with increased risk of infection. In contrast, a large, prospective, multicenter study (Hoen, 2002) found no relation between serum ferritin or treatment with intravenous iron and risk of bacteremia. The current literature on this subject remains inconclusive (Brookhart, 2013), but a prudent

approach would be to avoid intravenous iron treatment during acute infectious episodes.

- 4) **Intravenous iron safety: Oxidation.** Iron is a highly oxidative substance, and treatment with intravenous iron has the potential to overburden the body's native antioxidant systems. Oxidative damage to tissue and molecules has been clearly demonstrated experimentally, although the clinical significance of such findings is not clear (Fishbane, 2014). A potential harmful effect of vascular oxidation would be an acceleration of atherosclerotic processes.

d. **Intravenous iron drugs.**

- 1) **Intravenous iron dextran.** Because of the higher expected risk of anaphylaxis, iron dextran use should generally be reserved for patients who have a long history of prior safe use of the drug. This is probably true for all current forms of iron dextran, but particularly the high molecular weight variety (Chertow, 2006). In nonuremic patients, immediate allergic reactions to intravenous iron dextran have been reported. These usually occur within 5 minutes of injection but may be delayed by 45 minutes or more. For this reason, epinephrine and other means to treat anaphylaxis must be at hand when intravenous iron dextran is administered. Importantly, Walters and Van Wyck (2005) reported that almost all severe reactions occur with the test dose or first therapeutic dose. Milder immediate hypersensitivity reactions to iron dextran infusion include itching and urticaria. Delayed reactions can manifest as lymphadenopathy, myalgia, arthralgia, fever, and headache.
- 2) **Sodium ferric gluconate.** Intravenous sodium ferric gluconate is a nondextran form of iron used in the United States since 1999 and in Europe for several decades. As discussed above, adverse reactions are probably less frequent and less severe than those seen with iron dextran. With single-dose exposure the rate of severe reactions was 0.04%, and no severe reactions were observed with repeated administration of 13,151 doses to 1,321 patients (Michael, 2002; Michael, 2004). Intravenous sodium ferric gluconate may be administered to hemodialysis patients in the amount of 1,000 mg given in divided doses over eight consecutive treatments (i.e., 125 mg/dose).
- 3) **Iron sucrose.** Intravenous iron sucrose was approved for use in the United States in 2000 and has been in use in Europe for many years. Like sodium ferric gluconate, the other widely used nondextran form of iron, reports generally indicate a good safety and efficacy profile. No serious adverse reactions occurred in 665 hemodialysis patients receiving 8,583 doses of the drug (Aronoff, 2004). The drug may be administered as iron replacement therapy, 100 mg for 10 consecutive doses, or as a weekly dose of 25–100 mg.
- 4) **Iron added to the dialysate.** Ferric pyrophosphate citrate (Triferic) is an iron compound designed to be added to the dialysis solution with the goal of adding a small amount of iron to the patient during each dialysis treatment. Preliminary phase 3 results of this compound have been encouraging (Lin, 2013), especially in reducing ESA dosage. A new drug application for Triferic

was filed in the United States in 2014 for use of this compound, but it is not yet available for clinical use.

e) **Other causes of ESA resistance.**

- 1) **Bleeding.** An important cause of an apparent hyporesponsiveness to ESA is bleeding. Sometimes, the bleeding may be occult, as in gastrointestinal blood loss. Often, the bleeding may be obvious, as in patients undergoing surgery, menstruating women, or those with accidents involving the vascular access. It is vitally important to limit blood loss by any means possible. In addition, fecal occult blood testing should be performed when unexplained ESA resistance is present.
- 2) **Red blood cell life span.** It is well known that RBC lifespan is 20%–30% shorter on average in hemodialysis or peritoneal dialysis patients than normal subjects. Recently, a correlation was found between the degree of shortening of RBC lifespan and ESA resistance, but no treatment has been devised to prolong RBC lifespan in those patients in whom lifespan is shortest (Dou, 2012).
- 3) **Inflammation and infection.** As with infection, inflammatory states lead to resistance to ESA therapy. In patients on dialysis, the underlying cause of inflammation may not be readily apparent. Cytokine release results in downregulation of expression of erythropoietin receptors on erythrocyte precursors. In addition, chronic inflammation and infection increases hepcidin production, which disrupts iron availability by diminishing intestinal iron absorption and release from reticuloendothelial cells (D'Angelo, 2013). There is no perfect marker for occult inflammation, but C-reactive protein (CRP) is a helpful test for predicting ESA hyporesponsiveness caused by inflammation (Kalantar-Zadeh, 2003). A retained, nonfunctioning renal allograft can increase CRP levels and be a source of EPO resistance (Lopez-Gomez, 2004). ESA resistance is increased in patients with evidence of cytomegalovirus (CMV) infection (Betjest, 2009), but, paradoxically, may be reduced in patients infected with hepatitis C (Seong, 2013). Also, in African American patients with sickle cell trait or hemoglobin C, a moderately higher average ESA dose is required (about 12%, Derebail, 2014).

A search for occult infection should be undertaken in patients with unexplained ESA resistance. If infection is present, higher doses of ESA may be effective by partially overcoming the temporary resistance. One occult site of infection is in old, nonfunctioning, arteriovenous grafts, where treatment of the infection may reverse ESA resistance (Nassar, 2002).

- 4) **Hyperparathyroidism.** Hyperparathyroidism may be a cause of ESA resistance. There is a clear relationship between elevated iPTH levels and diminished ESA response. In addition, after parathyroidectomy, responsiveness improves (Al-Hilali, 2007). It does not appear that parathyroid hormone itself inhibits erythropoiesis. The pathogenesis is incompletely understood, but appears to represent a complex interplay of a variety of pathogenic factors. In the ESA-

resistant patient who is found to have elevated iPTH levels, an intensification of the treatment of hyperparathyroidism is indicated.

- 5) **Vitamin D.** Data suggest that Hgb levels are lower in dialysis patients with low serum levels of 25-hydroxyvitamin D, and vitamin D is a potent suppressor of hepcidin in humans, suggesting that treatment with vitamin D may improve anemia management. Although some preliminary data suggest that vitamin D treatment may be of some use, at present, results are preliminary and require confirmation by larger randomized trials (see Icardi, 2013)
- 6) **Relative vitamin B₁₂ deficiency.** Vitamin B₁₂ and folic acid levels should be checked when unexplained ESA resistance is present; a case can be made for more routine evaluation of this parameter. Many dialysis patients are taking proton-pump inhibitors, known to be associated with subnormal B₁₂ levels, and intensive, high-flux hemodialysis and hemodiafiltration treatments have been shown to lower vitamin B₁₂ levels. In one study from Australia (Killen, 2014), 91/142 hemodialysis patients had serum vitamin B₁₂ levels of less than 300 pmol/L, a level suggesting deficiency. Only five patients had levels of less than 150 pmol/L, which represents clear-cut deficiency. A short course of three treatments of hydroxycobalamin 1,000 mcg per week was given. Treatment was repeated if B₁₂ levels remained below 300 pmol/L. Hydroxycobalamin treatment resulted in a more than 50% reduction in median EPO requirement, from 11 to 5 thousand units per week. IV iron requirements were also reduced by half. The authors also suggest that cyanocobalamin (a form of B₁₂ commonly used in oral supplements) should not be given to ESKD patients because of cyanide accumulation, but that hydroxycobalamin be used. In this study, B₁₂ was given intramuscularly. It is not clear whether subcutaneous administration would lead to similar results.
- 7) **Inadequate dialysis.** In the urea reduction ratio (*URR*) range of 60 to 75%, there appears to be a weak association with increased hematocrit and higher levels of *URR* (Ifudu, 2000). Beyond that, careful, randomized studies of more frequent dialysis (i.e., the FHN Trials), either in-center or nocturnal, have shown no benefit in terms of increasing ESA responsiveness.
- 8) **Aluminum intoxication.** Although problems with aluminum have become less common among dialysis patients, occasional problems may still occur, especially in patients who have been on dialysis for many years. The effect on erythropoiesis is a microcytic anemia associated with impaired iron utilization. Interestingly, intestinal aluminum absorption is significantly increased in patients with iron deficiency. A serum aluminum level provides a rough guide to aluminum status; if the results are suggestive, either a deferoxamine stimulation test or a bone biopsy may be warranted.
- 9) **Angiotensin-converting enzyme (ACE) inhibitors.** ACE inhibitors may reduce EPO production in patients with chronic renal failure or following renal transplant. Among patients on dialysis, a reduction in ESA responsiveness has not been

uniformly demonstrated in association with these agents.

- 10) **Pure red cell aplasia.** An outbreak of immune-mediated pure red cell aplasia has been reported, primarily in Europe, in association with ESA treatment. In the first 10 years of worldwide ESA availability, only three cases were noted among more than a million treated patients. Subsequently, the rate increased dramatically, with at least 184 cases reported between 1998 and 2003. In ESA-associated pure red cell aplasia, Hgb declines rapidly as does the reticulocyte count. Patients become transfusion-dependent, and the bone marrow demonstrates absence of erythroid precursors. The cause is the development of antierythropoietin antibodies that neutralize both therapeutic and endogenous erythropoietin. The majority of cases occurred in Europe, with epoetin alfa sold under the brand name of Eprex. After a peak in cases in 2002, the number declined substantially, but sporadic cases continued to develop. The cause of the syndrome (why do antierythropoietin antibodies develop) was never fully elucidated. Certain biosimilar forms of ESAs have been associated with a greater risk for antierythropoietin antibodies, so vigilance is required as use of biosimilar ESAs increases.
 - 11) **Other hematologic disease.** Patients on dialysis are at risk for developing the same hematologic diseases as nonuremic subjects. Because of the emphasis on EPO deficiency, other hematologic diseases may go unrecognized. Among the potential causes not already discussed above are hematologic malignancy, myelodysplastic syndromes, and hemolysis. When an exhaustive evaluation for causes of ESA resistance is unrevealing, hematology consultation and a bone marrow biopsy may be considered as a last step in the process to rule out unexpected hematologic disease.
- G. **Red blood cell transfusions.** Transfusion of packed red cells should be used in severely anemic patients who are experiencing symptoms. Transfusion should never be utilized without a concurrent evaluation for causes of bleeding.
 - H. **Carnitine.** It has been suggested that carnitine may enhance responsiveness to ESA. A recent multicenter, randomized, double-blind, placebo-controlled trial found that administration of carnitine failed to improve response to ESA therapy (Mercadal, 2012). The 2012 KDIGO anemia in CKD guidelines do not recommend the use of carnitine as an adjuvant to ESA treatment.
 - I. **Ascorbic acid.** Although the literature is mixed, several studies have found that intravenous ascorbic acid may improve epoetin responsiveness for patients on hemodialysis. A typical regimen is intravenous vitamin C given three times weekly with the hemodialysis treatment. Deved (2009) conducted a meta-analysis. While concerned about small sample sizes and deficits in study quality, the authors found ascorbic acid to generally result in increased Hgb and decreased ESA dose. Since vitamin C may lead to increases in oxalate production, appropriate caution must be used in patient selection and duration of therapy.

II. HEMOLYSIS

- A. **General comments.** Destruction of RBCs, either intravascularly or extravascularly, may

occasionally contribute to anemia in dialysis patients. Generally speaking, red cell survival appears to be shortened with chronic renal failure (approximately 30% compared with healthy subjects [Ly, 2004]). It is likely that this is due not to an inherent abnormality of the red cell, but to an effect of the uremic environment.

- B. **Diagnosis.** Chronic hemolysis should be suspected when the patient develops high-grade ESA resistance in the presence of increased serum lactic dehydrogenase (LDH), unconjugated bilirubin, or a decrease in serum haptoglobin. The differential diagnosis of chronic hemolysis is broad, and includes all causes of hemolysis seen in nonuremic patients (Table 34.2) and several causes specific to patients treated with hemodialysis. Occasionally, hemolysis can be severe, associated with hypotension, or sometimes hypertension, and with abdominal, chest, and/or back pain, shortness of breath, nausea, vomiting, or diarrhea, and encephalopathy developing during the dialysis procedure (Duffy, 2000).
- C. **Etiology.** The most common correctible cause of hemolysis is due to some problem with the hemodialysis system. Faulty or kinked blood line tubing can do this via mechanical damage to RBCs. Chloramine in the dialysis solution; use of a hypotonic or overheated dialysis solution; copper, zinc, or nitrate in the water supply; or formaldehyde not rinsed out of the dialyzer after reprocessing, are among the causes. Machine/dialysis solution–based issues are discussed in Chapters 4 and 5.
- D. **Treatment.** If acute, severe hemolysis is suspected, the dialysis treatment should be terminated immediately. Circulatory support should be provided as needed, and an electrocardiogram must be obtained to determine whether hyperkalemic changes are present (which may be delayed) and to assess for acute cardiac ischemia. A blood sample should be obtained for determination of hemoglobin, hematocrit, and serum chemistries, especially serum potassium.

TABLE

34.2

Causes of Hemolysis in Dialysis Patients

Related to the hemodialysis procedure

Dialysis solution

Contaminants

Chloramine

Copper, zinc

Nitrates, nitrites

Overheated

Hypo-osmolar

Reuse of sterilants (formaldehyde)

Kinked or defective tubing—trauma to RBCs

Needle trauma to RBCs

Subclavian catheter (helmet cells, schistocytes)

Malfunctioning cardiac valve prosthesis

Insufficient dialysis

Hypersplenism

Associated diseases

Sickle cell anemia

Other hemoglobinopathies

Connective tissue diseases with vasculitis

Drug-induced

Hypophosphatemia

III. DISORDERS OF HEMOSTASIS.

- A. **Introduction.** The formation of a blood clot in response to vascular injury is a complex and highly conserved process in mammalian species. Disorders of platelet quantity or function can lead to bleeding in superficial sites, such as the skin and mucous membranes. Disorders of the coagulation system usually lead to bleeding into deeper structures, such as muscle and joints. Prior to the introduction of dialysis, bleeding tendencies were long recognized among uremic subjects. Dialysis partially reverses the abnormal hemostasis, but ecchymoses, excessive access bleeding, and occasional severe bleeding episodes still occur.
- B. **Pathophysiology.** Many factors contribute to the deranged state of uremic hemostasis, with disorders in platelet function (thrombasthenia) being most important. Platelet counts may be slightly reduced, but commonly are normal in well-dialyzed patients, and severe thrombocytopenia is uncommon. Platelet aggregation is abnormal, probably because of reduced platelet granule adenosine phosphate and serotonin levels, and defective thromboxane A₂ production. Platelet function may also be hindered in uremic patients by increased endothelial nitric oxide production (Remuzzi, 1990). An adhesion receptor, the glycoprotein (GP) IIb–IIIa complex, plays an important role in controlling the formation of platelet thrombi. In uremic patients, the activation of the GP IIb–IIIa receptor is impaired, but activation is partially restored by dialysis. There has been a suggestion that abnormalities of von Willebrand factor (important for maintaining platelet adhesion in rapid blood flow) may contribute to disordered uremic hemostasis, but study results have been inconsistent. Anemia itself probably contributes to uremic bleeding; abnormally prolonged bleeding time is significantly improved when the hematocrit is increased to >30%. The hemodialysis procedure itself may impact on platelet number and function. Polysulfone dialyzers sterilized by electron beam have been reported to cause a reduction in platelet count, but this effect may vary with how the membrane is produced, and is not a consistent finding. Antiplatelet drugs may further impair platelet function in ESKD. Hemodialysis patients have a greater risk of bleeding complications while on these drugs than the general population (Hiremath, 2009).
- C. **Assessment.** Disordered hemostasis should be evaluated in terms of clinical manifestations and by testing of skin bleeding time. Patients with ecchymoses, excessive access bleeding, or any clinically significant bleeding episodes (including hemorrhagic pericarditis) should have platelet count, prothrombin time, partial thromboplastin time, and bleeding time

tested. The bleeding time becomes abnormal when the platelet count is markedly decreased, when platelet function is impaired, or if the vascular wall is damaged. The risk of hemorrhage increases when the bleeding time is elevated to more than 10 minutes.

- D. **Treatment.** The management of dialysis patients experiencing bleeding requires (a) an estimate of the severity of blood loss, (b) hemodynamic stabilization, (c) transfusion with blood products as needed, (d) identification of the bleeding source, and (e) treatment of platelet dysfunction and other factors contributing to the bleeding diathesis. Intensive dialysis of previously underdialyzed patients often results in some improvement in bleeding tendency. The administration of cryoprecipitate (a plasma extract with high concentrations of von Willebrand factor) does not consistently result in improved platelet function. In one study, only two of five treated patients had normalized bleeding time and a favorable outcome (Triulzi, 1990). Desmopressin (a synthetic analog of antidiuretic hormone) leads to increased release of von Willebrand factor multimers. A dose of 0.3 mcg/kg body weight may be administered diluted in 50 mL of saline intravenously over 30 minutes. In a well-designed study, this regimen led to a reduction in bleeding time in 1 hour, which lasted for 8 hours. The drug has little vasoconstrictive effect and should not cause hyponatremia in ESKD patients. Finally, repetitive intravenous infusions of conjugated estrogens may reduce bleeding time significantly. More practically, one oral dose of 25 mg conjugated estrogen (Premarin) normalizes bleeding time for up to 10 days. This effect is in contrast to the relatively short period of action of cryoprecipitate or desmopressin. We recommend the use of desmopressin empirically for dialysis patients with severe acute bleeding. In contrast, conjugated estrogens may be helpful in correcting an abnormal bleeding time prior to planned surgery or to treat chronic gastrointestinal bleeding in patients with telangiectasia. Estrogens alone, PO, IV, or transdermally (Sloand & Schiff, 1995), or estrogen–progesterone combinations have all been used (Boccardo, 2004).

References and Selected Readings

- Alarcon MC, et al. Hormone therapy with estrogen patches for the treatment of recurrent digestive hemorrhages in uremic patients. *Nefrologia*. 2002;22:208–209.
- Al-Hilali N, et al. Does parathyroid hormone affect erythropoietin therapy in dialysis patients? *Med Princ Pract*. 2007;16:63–67.
- Aronoff G, et al. Iron sucrose in hemodialysis patients: safety of replacement and maintenance regimens. *Kidney Int*. 2004;66:1193–1198.
- Besarab A, et al. The effects of normal as compared with low hematocrit values in patients with cardiac disease who are receiving hemodialysis and epoetin. *N Engl J Med*. 1998;339:584–590.
- Betjest MGH, Weimar W, Litjens NHR. CMV seropositivity determines epoetin dose and hemoglobin levels in patients with CKD. *J Am Soc Nephrol*. 2009;20:2661–2666.
- Boven K, et al. Epoetin-associated pure red cell aplasia in patients with chronic kidney disease: solving the mystery. *Nephrol Dial Transplant*. 2005;20(suppl 3):iii33–iii40.
- Brookhart MA, et al. Infection risk with bolus versus maintenance iron supplementation in hemodialysis patients. *J Am Soc Nephrol*. 2013;24:1151–1158.
- Brugnara C. Iron deficiency and erythropoiesis: new diagnostic approaches. *Clin Chem*.

2003;49:1573–1578.

- Chertow GM, et al. Update on adverse effects associated with parenteral iron. *Nephrol Dial Transplant*. 2006;21:378–382.
- Coritsidis GN, et al. Anemia management trends in hospital-based dialysis centers (HBDCs), 2010 to 2013. *Clin Therap*. 2014;36:408–418.
- D'Angelo G. Role of hepcidin in the pathophysiology and diagnosis of anemia. *Blood Res*. 2013;48:10–15.
- Daugirdas JT, Bernardo AA. Hemodialysis effect on platelet count and function and hemodialysis-associated thrombocytopenia. *Kidney Int*. 2012;82:147–157.
- Derebail VK, et al. Sickle trait in African-American hemodialysis patients and higher erythropoiesis-stimulating agent dose. *J Am Soc Nephrol*. 2014;25:819–826.
- Deved V, et al; Alberta Kidney Disease Network. Ascorbic acid for anemia management in hemodialysis patients: a systematic review and meta-analysis. *Am J Kidney Dis*. 2009;54:1089–1097.
- Drüeke TB, et al, and the CREATE Investigators. Normalization of hemoglobin level in patients with chronic kidney disease and anemia. *N Engl J Med*. 2006;355:2071–2084.
- Dou Y, et al. Red blood cell life span and 'erythropoietin resistance'. *Kidney Int*. 2012;81:1275–1276.
- Duffy R, et al. Multistate outbreak of hemolysis in hemodialysis patients traced to faulty blood tubing sets. *Kidney Int*. 2000;57:1668–1674.
- Escolar G, Diaz-Ricart M, Cases A. Uremic platelet dysfunction: past and present [Review]. *Curr Hematol Rep*. 2005;4:359–367.
- Fishbane S, et al. A randomized trial of iron deficiency testing strategies in hemodialysis patients. *Kidney Int*. 2001;60:2406–2411.
- Fishbane S, Mathew A, Vaziri ND. Iron toxicity: relevance for dialysis patients. *Nephrol Dial Transplant*. 2014;29:255–259.
- Foley RN, et al. Effect of hemoglobin levels in hemodialysis patients with asymptomatic cardiomyopathy. *Kidney Int*. 2000;58:1325–1335.
- Furuland H, et al. A randomized controlled trial of haemoglobin normalization with epoetin alfa in pre-dialysis and dialysis patients. *Nephrol Dial Transplant*. 2003;18:353–361.
- Gaweda AE, et al. Determining optimum hemoglobin sampling for anemia management from every-treatment data. *Clin J Am Soc Nephrol*. 2010;5:1939–1945.
- Gaweda AE, et al. Individualized anemia management reduces hemoglobin variability in hemodialysis patients. *J Am Soc Nephrol*. 2014;25:159–166.
- Gunnell J, et al. Acute-phase response predicts erythropoietin resistance in hemodialysis and peritoneal dialysis patients. *Am J Kidney Dis*. 1999;33:63–72.
- Hazzan AD, et al. ESA treatment and cancer. *Kidney Int*. 2014;86:34–39.
- Hiremath S, et al. Antiplatelet medications in hemodialysis patients: a systematic review of bleeding rates. *Clin J Am Soc Nephrol*. 2009;4:1347–1355.
- Hoehn B, et al. Intravenous iron administration does not significantly increase the risk of bacteremia in chronic hemodialysis patients. *Clin Nephrol*. 2002;57:457–461.
- Icardi A, et al. Renal anaemia and EPO hyporesponsiveness associated with vitamin D deficiency: the potential role of inflammation. *Nephrol Dial Transplant*. 2013;28:1672–1679.

- Ifudu O, et al. Adequacy of dialysis and differences in hematocrit among dialysis facilities. *Am J Kidney Dis.* 2000;36:1166-74.
- Kalantar-Zadeh K, et al. Effect of malnutrition-inflammation complex syndrome on EPO hyporesponsiveness in maintenance hemodialysis patients. *Am J Kidney Dis.* 2003;42:761-773.
- Kaufman JS, et al. Subcutaneous compared with intravenous epoetin in patients receiving hemodialysis. Department of Veterans Affairs Cooperative Study Group on Erythropoietin in Hemodialysis Patients. *N Engl J Med.* 1998;339:578-583.
- Kaw D, Malhotra D. Platelet dysfunction and end-stage renal disease. *Semin Dial.* 2006;19:317-22.
- Killen JP, Brenninger VL. Hydroxycobalamin supplementation and erythropoiesis stimulating agent hyporesponsiveness in haemodialysis patients. *Nephrology.* 2014;19:164-171.
- Kshirsagar AV, et al. The comparative short-term effectiveness of iron dosing and formulations in us hemodialysis patients. *Am J Med.* 2013a;126:541.
- Kshirsagar AV, et al. Intravenous iron supplementation practices and short-term risk of cardiovascular events in hemodialysis patients. *PLoS One.* 2013b;8:e78930.
- Levin A, et al. Canadian randomized trial of hemoglobin maintenance to prevent or delay left ventricular mass growth in patients with CKD. *Am J Kidney Dis.* 2005;46:799-811.
- Lines SW, et al. A predictive algorithm for the management of anaemia in haemodialysis patients based on ESA pharmacodynamics: better results for less work. *Nephrol Dial Transplant.* 2012;27:2425-2429.
- Lin VH, et al. Soluble ferric pyrophosphate (SFP) administered via dialysate reduces ESA requirements in CKD-HD patients with ESA hypo-response, SA-OR082 [abstract]. *J Am Soc Nephrol.* 2013;24:90A.
- Lopez-Gomez JM, et al. Presence of a failed kidney transplant in patients who are on hemodialysis is associated with chronic inflammatory state and erythropoietin resistance. *J Am Soc Nephrol.* 2004;15:2494-2501.
- Ly J, et al. Red blood cell survival in chronic renal failure. *Am J Kidney Dis.* 2004;44:715-719.
- Macdougall IC, et al. Pharmacokinetics of novel erythropoiesis stimulating protein (NESP) compared with epoetin alfa in dialysis patients. *J Am Soc Nephrol.* 1999;10:2392-2395.
- Mercadal L, et al. L-carnitine treatment in incident hemodialysis patients: the multicenter, randomized, double-blinded, placebo-controlled CARNIDIAL trial. *Clin J Am Soc Nephrol.* 2012;7:1836-1842.
- Michael B, et al. Sodium ferric gluconate complex in hemodialysis patients: adverse reactions compared to placebo and iron dextran. *Kidney Int.* 2002;61:1830-1839.
- Michael B, et al. Sodium ferric gluconate complex in haemodialysis patients: a prospective evaluation of long-term safety. *Nephrol Dial Transplant.* 2004;19:1576-1580.
- Nassar GM, et al. Occult infection of old nonfunctioning arteriovenous grafts: a novel cause of erythropoietin resistance and chronic inflammation in hemodialysis patients. *Kidney Int Suppl.* 2002;(80):49-54.
- Noris M, Remuzzi G. Uremic bleeding: closing the circle after 30 years of controversies? *Blood.* 1999;94:2569-2574.
- Ofsthun N, et al. The effects of higher hemoglobin levels on mortality and hospitalization in hemodialysis patients. *Kidney Int.* 2003;63:1908-1914.
- Parfrey PS, et al. Double-blind comparison of full and partial anemia correction in incident

hemodialysis patients without symptomatic heart disease. *J Am Soc Nephrol*. 2005;16:2180–2189.

Pfeffer MA, et al, and the TREAT Investigators. A trial of darbepoetin alfa in type 2 diabetes and chronic kidney disease. *N Engl J Med*. 2009;361:2019-2032.

Pillon L, Manzone T. Accuracy of anemia evaluation is improved in a wide variety of acute and chronically ill patients by accounting for volume status. *J Am Soc Nephrol*. 2008;19:164A.

Pollak VE, Lorch JA. Macrocytosis in chronic hemodialysis (HD) patients [abstract]. *J Am Soc Nephrol*. 2005;16:477A.

Remuzzi G, et al. Role of endothelium derived nitric oxide in the bleeding tendency of uremia. *J Clin Invest*. 1990;86:1768–1771.

Rodrigue MF, et al. Relationship between eicosanoids and endothelin-1 in the pathogenesis of erythropoietin-induced hypertension in uremic rats. *J Cardiovasc Pharmacol*. 2003;41:388–395.

Roob JM, et al. Vitamin E attenuates oxidative stress induced by intravenous iron in patients on hemodialysis. *J Am Soc Nephrol*. 2000;11:539–549.

Singh AK, et al and the CHOIR Investigators. Correction of anemia with epoetin alfa in chronic kidney disease. *N Engl J Med*. 2006;355:2085-2098.

Sloand JA, Schiff MJ. Beneficial effect of low-dose transdermal estrogen on bleeding time and clinical bleeding in uremia. *Am J Kidney Dis*. 1995;26:22–26.

Spinowitz BS, et al. The safety and efficacy of ferumoxytol therapy in anemic chronic kidney disease patients. *Kidney Int*. 2005;68:1801–1806.

Triulzi DJ, Blumberg N. Variability in response to cryoprecipitate treatment for hemostatic defects in uremia. *Yale J Biol Med*. 1990;63:1–7.

Umanath K, et al. Ferric citrate as a phosphate binder reduces IV iron and erythropoietin stimulating agent (ESA) use, SA-PO-521 [abstract]. *J Am Soc Nephrol*. 2013;24:221A.

Van Wyck DB, et al. Safety and efficacy of iron sucrose in patients sensitive to iron dextran: North American Clinical Trial. *Am J Kidney Dis*. 2000;36:88–97.

Walters BA, Van Wyck DB. Benchmarking iron dextran sensitivity: reactions requiring resuscitative medication in incident and prevalent patients. *Nephrol Dial Transplant*. 2005;20:1438–1442.

Xia H, et al. Hematocrit levels and hospitalization risks in hemodialysis patients. *J Am Soc Nephrol*. 1999;10:1309–1316.

I. DERANGEMENT OF IMMUNE FUNCTION IN UREMIA

A. **Etiology.** In dialysis patients, there is impairment of several aspects of lymphocyte and granulocyte function. Unidentified uremic toxins are thought to be responsible; malnutrition or vitamin D deficiency can sometimes be contributory factors.

B. **Clinical implications**

1. **Increased susceptibility to infection**

- a. **Frequency of bacterial infections.** Bacterial infections occur more often in dialysis patients than in their nonuremic counterparts; the increase is probably related more to frequent violation of normal skin and mucosal barriers than to immune system dysfunction.
- b. **Severity of bacterial infections.** Owing to the presence of a vascular access, infections in hemodialysis patients are often associated with bacteremia, and there is a substantial risk of serious complications such as endocarditis, osteomyelitis, and epidural abscess. Use of a hemodialysis catheter is associated with a threefold increase in hospitalization and death from septic complications as compared with use of a native or graft fistula. In peritoneal dialysis patients, peritonitis is rarely associated with systemic infection.
- c. **Role of hemodialysis membrane or peritoneal dialysis solution.** Some of the immune defects previously attributed to uremia may be due, in part, to periodic exposure of the blood to certain dialysis membranes or to lack of removal of putative inhibitors of immune function by low-flux membranes. However, in the HEMO study, infection-related deaths were not reduced by utilization of biocompatible, high-flux dialyzers (Allon, 2004). In peritoneal dialysis patients, peritoneal neutrophil function is depressed owing to removal of opsonins (immunoglobulin and complement) in the dialysate and to regular exposure to low pH, high osmolality, and glucose degradation products present in some dialysis solutions.

II. DERANGEMENT OF TEMPERATURE CONTROL IN UREMIA

A. **Baseline hypothermia in uremic patients.** In about 50% of hemodialysis patients, the predialysis

body temperature is subnormal. The reason for this is unknown.

- B. **Reduced pyrexia response associated with infections.** Uremia per se does not appear to affect the temperature response to pyrogens. In addition, the degree of interleukin-1 (IL-1) production by stimulated uremic monocytes is normal. However, because of baseline hypothermia, and possibly because of frequently coexisting malnutrition, severe infections in some dialysis patients may be associated with an attenuated or absent fever response.

III. BACTERIAL INFECTIONS IN DIALYSIS PATIENTS

A. Related to the access site

1. **Hemodialysis patients.** Prevention, diagnosis, and treatment of vascular access infections are described in Chapters 9 (venous catheters) and 8 (fistulas and grafts). Several additional clinical points are emphasized here.
 - a. **Bacteremia versus pyrogen reaction.** The dialysis patient with bacteremia generally presents with chills and fever and may appear quite toxic. On occasion, however, symptoms and signs of infection are remarkably few or absent. Although redness, tenderness, or exudate at the access site may help to incriminate it as the source of the infection, in many cases an infected access site can appear normal. Delayed treatment of sepsis in dialysis patients is an important cause of morbidity and mortality. In general, patients with venous hemodialysis catheters and fever should be assumed to have catheter-related bacteremia and treated with broad-spectrum antibiotics pending results of blood cultures.
 1. **Pyrogen reaction.** Low-grade fever during hemodialysis may be related to pyrogens present in the dialysis solution rather than to actual infection. The time course of fever may be somewhat helpful in making the distinction between pyrogen reaction and infection: Patients with pyrogen-related fever are afebrile prior to dialysis but become febrile during dialysis; fever resolves spontaneously after cessation of dialysis. Patients with access site-related bacteremia are often febrile prior to institution of dialysis and, in the absence of treatment, fever persists during and after dialysis. There is one exception to the rule: Fever and chills that occur shortly after catheter manipulation (for instance, commencement or cessation of dialysis) suggests catheter-associated bacteremia. Use of high-flux dialysis (especially in conjunction with bicarbonate dialysate) and dialyzer reuse are associated with an increased incidence of pyrogenic reactions. Blood cultures should always be obtained in any febrile hemodialysis patient, even when a pyrogen reaction is the suspected cause of the fever and, in most cases, antibiotics should be administered until infection is excluded.
 2. **Contamination of hemodialysis machines or solutions.** Occasionally, bacteremia may result from contamination of hemodialysis machines. These are generally gram-negative and occasionally fungal infections. Outbreaks of such infections have been caused by inadequate disinfection of water treatment or distribution systems or reprocessed dialyzers (Rao, 2009). Contamination of the waste drain ports of the hemodialysis machine has also been described.

b. **Prophylactic antimicrobial administration**

1. **Prophylaxis prior to an invasive procedure likely to result in bacteremia.** Although there is no definite evidence in the literature, it is our policy to administer antimicrobial prophylaxis to hemodialysis patients prior to invasive procedures associated with a substantial risk of bacteremia because of the abnormal vascular communication present. These include dental procedures (especially extractions); gastrointestinal (GI) procedures such as esophageal stricture dilation, sclerotherapy for esophageal varices, and endoscopic retrograde cholangiography with biliary obstruction (not necessary for routine endoscopy with or without biopsy); and genitourinary procedures including cystoscopy, urethral dilation, and transurethral prostate resection. The recommended antimicrobial is amoxicillin 2.0 g given 1 hour before the procedure (or ampicillin 2.0 g IM or IV given 30 minutes before the procedure). In penicillin-allergic patients, either clindamycin 600 mg by mouth or IV (dental or esophageal procedures) or vancomycin 1.0 g IV (other GI and genitourinary procedures) can be substituted.
2. **Long-term, continuous prophylaxis.** The skin and nasal carriage rate of *Staphylococcus aureus* in hemodialysis patients is about 50%. Intranasal mupirocin ointment is effective in eradicating the carrier state and in uncontrolled studies has decreased the incidence of staphylococcal infection. Decision analysis suggests that weekly use of this agent in all patients without screening will decrease infection rates and is cost effective (Bloom, 1996). However, a major concern is the development of mupirocin resistance with chronic use. In general, there is insufficient evidence to support routine *Staphylococcus aureus*, including methicillin-resistant *Staphylococcus aureus* (MRSA) decolonization.

On the other hand, a reduction in catheter-related bacteremia has been demonstrated by use of prophylactic topical antimicrobial ointments at the catheter exit site, the use of prophylactic catheter locking solutions, fastidious catheter care, and the use of vascular access managers and quality initiative programs (Lok and Mokrzycki, 2011). Their use is particularly beneficial in patients who have nasal carriage of *Staphylococcus aureus*. Dry gauze dressings rather than transparent film dressings are recommended because transparent film dressings pose a greater threat of exit site colonization (Conly, 1989). A surgical mask worn by the patient and nurse any time the catheter is accessed reduces the spread of infectious droplets and reduces contamination of the catheter site.

- c. **Vancomycin-resistant gram-positive infections.** Concern about an increasing prevalence of vancomycin-resistant enterococci (VRE) in hospitalized patients has resulted in recommendations that vancomycin use be restricted in dialysis patients. Because of the relatively high incidence of staphylococcal organisms resistant to antistaphylococcal penicillins and cephalosporins, it is currently our policy to utilize vancomycin as initial therapy of life-threatening suspected *S. aureus*

infections (e.g., catheter-related bacteremia). If sensitivity results warrant, vancomycin can be discontinued in several days, and prolonged treatment with an alternative antibiotic can then be employed. Certain cephalosporins (e.g., cefazolin) have a very prolonged half-life in end-stage kidney disease (ESKD) patients and can be dosed conveniently postdialysis.

2. Peritoneal dialysis patients.

- a. **Antimicrobial prophylaxis.** In the absence of other indications for prophylaxis, we do not routinely administer antibiotics prior to invasive procedures unless a vascular access is present. Long-term, continuous prophylaxis is discussed in Chapter 27.

B. Unrelated to the access site

1. **Urinary tract infection (UTI).** In dialysis patients, the incidence of UTI is high, especially in patients with polycystic kidney disease.

- a. **Clinical presentation.** In oliguric patients, the symptoms of cystitis are similar to those in nonuremic individuals, although gross hematuria is unusually common and occurs in up to one-third of cases. Anuric patients may present with suprapubic discomfort or foul-smelling urethral discharge and progress to pyocystitis (see below).
- b. **Diagnosis.** Voided urine samples from oliguric patients, even from those voiding only a few milliliters per day, are usually sufficient for diagnosis. Urethral catheterization and bladder lavage may cause infection and should be reserved for the symptomatic anuric patient. The presence of pyuria is not a useful finding to rule in or rule out infection. Absence of visible bacteria does not rule out UTI. A urine culture is essential to make the diagnosis. As in nonuremic patients, a colony count greater than 10^3 in a properly collected urine specimen is considered to be suggestive of infection, but there are no good studies in dialysis patients.
- c. **Treatment.** Optimally, antimicrobial therapy should be based on sensitivity testing of the organism involved. If empirical therapy is warranted, penicillin, ampicillin, cephalexin, a fluoroquinolone, or trimethoprim should be used because they are safe and may attain adequate urine levels in ESKD patients. Male patients from susceptible populations (Asian and Mediterranean) should be tested for glucose-6-phosphatase deficiency before receiving trimethoprim–sulfamethoxazole. In female dialysis patients, trimethoprim–sulfamethoxazole is generally chosen over ampicillin for treatment of recurrent UTIs; trimethoprim–sulfamethoxazole is less likely to be associated with the emergence of resistant organisms in the fecal flora, the source of most urinary pathogens in women.

The most appropriate treatment schedule for dialysis patients with cystitis has not been well studied. A urine culture should be repeated on the third or fourth day of treatment documenting that the urine shows no growth, and therapy should be continued for a total of 5–7 days. Ten days of antimicrobial therapy is warranted in patients with adult polycystic kidney disease because of their increased susceptibility to pyogenic complications of UTIs. A follow-up urine culture should be obtained 7–10 days after completing therapy.

It is difficult to achieve adequate urinary drug levels of ticarcillin,

doxycycline, sulfisoxazole, and the aminoglycosides in dialysis patients; hence, these agents are not recommended for treatment of cystitis. However, when the responsible urinary pathogen is resistant to trimethoprim–sulfamethoxazole, cephalexin, fluoroquinolones, and the penicillins, one of these alternative drugs can be employed if its use is supported by the results of bacterial sensitivity. The use of nalidixic acid, nitrofurantoin, tetracycline, or methenamine mandelate is generally contraindicated in anuric patients due to the prolonged half-lives of these agents and the accumulation of toxic metabolites.

If repeated culture and sensitivity testing show bacterial resistance, the antimicrobial therapy should be adjusted. If the original infecting organism is still sensitive to the initial therapy, the dosage should be increased if possible or intravesical antimicrobial therapy should be administered. If a source of bacteria, such as a staghorn calculus, is identified, it must be removed to cure the UTI permanently. Bacterial persistence is a recurrent infection from a source within the urinary tract. It is suspected if infections with the same bacteria return immediately after treatment is completed. Causes include infected cysts, infection stones (e.g., staghorn calculus), and bacterial prostatitis. Reinfection is a recurrent infection caused by the same or different species of bacteria entering the urinary tract at varied intervals. Reinfection is not usually due to an identifiable anatomic lesion but rather to reintroduction of bacteria from a source outside the urinary tract, most frequently the rectal flora. Vesicoenteric and vaginal fistulas are rare causes of reinfection.

All patients with recurrent infection should be evaluated for residual urine and urethral stenosis, urethral stricture, or bladder outlet obstruction. A renal ultrasonographic study and plain film tomograms of the kidney should be obtained in dialysis patients with possible bacterial persistence. Computed tomography (CT) with and without contrast infusion may be used if ultrasonographic findings are indeterminate. Cystoscopy is recommended if hematuria occurs or to help rule out enterovesical fistula in patients with pneumaturia. Ureteral catheter localization studies should also be performed if bacterial persistence is suspected. Patients found to have a congenital or acquired anatomic abnormality responsible for their infections should have the defect removed surgically. The safety of long-term antimicrobial prophylaxis in dialysis patients with frequent urinary bladder reinfections is not known. Low-dose trimethoprim–sulfamethoxazole and cephalexin would probably be the safest drugs to use.

- d. **Upper urinary tract infections and pyogenic complications.** Upper tract infections in dialysis patients occur most commonly as a result of retrograde ascent of urinary pathogens in the urinary tract. Rarely, acute pyelonephritis occurs in dialysis patients from a hematogenic route. Patients with cystic kidneys and especially those with adult polycystic disease are particularly susceptible to upper tract infection and its complications. Infected cysts, pyonephrosis, and renal and perirenal abscesses may develop.

A patient with an infected cyst or renal or perirenal abscess usually presents

with dysuria, recurrent UTIs, fever, night sweats, abdominal or flank pain, or sepsis. Occasionally, the patient may be asymptomatic. A tender, tense mass may be palpable in the flank or abdomen. With systemic symptoms, these patients may develop dehydration due to poor fluid and food intake, sweating, and fever.

Leukocytosis is commonly present. Urine culture will identify the responsible organism if the parenchymal infection communicates with the collecting system. However, culture results can be negative when an infected cyst does not communicate with the urinary tract, or when there is pyonephrosis due to a cyst or stone that completely obstructs the ureter. Ultrasonography or CT may identify infected cysts and provide a point of reference for determining response to antimicrobial therapy. The use of indium-111 (^{111}In) leukocyte imaging and gallium-67 (^{67}Ga) citrate single photon emission computed tomography (SPECT) transaxial imaging in localizing infected cysts has been described and may be considered when findings from ultrasonography or CT are inconclusive.

In patients with cystic kidneys, antimicrobial therapy of upper tract infection should be continued for at least 3 weeks. Many antimicrobials penetrate renal cysts poorly, and the degree of antimicrobial penetration depends on whether the cysts are derived from the proximal tubule or the distal nephron. Lipid-soluble trimethoprim, ciprofloxacin, metronidazole, clindamycin, erythromycin, and doxycycline have been shown to achieve good bactericidal levels in the fluids of both types of cysts, and should be good treatment selections, depending on the suspected organism. Ciprofloxacin has been shown to sterilize infected cysts in some patients. Non-lipid-soluble antimicrobials, such as the aminoglycosides, the third-generation cephalosporins, and the penicillins, have generally failed to cure infections in polycystic kidneys, presumably because of their poor penetration into cysts derived from the distal nephron.

Patients with adult polycystic kidneys with bacterial persistence localizing to one side (as documented by ureteral catheter localization studies) should have the source of infection removed surgically. Pyonephrosis and renal and perirenal abscesses cannot be cured by antimicrobial therapy alone, and require immediate and definitive surgical intervention. Percutaneous drainage of an infected cyst under radiographic imaging may be appropriate in medically unstable patients, but surgical intervention currently remains the procedure of choice for most localized abscesses. Laparoscopic unroofing of a clearly identifiable infected cyst may be considered. Nephrectomy is indicated only when an infected cyst is unresponsive to antimicrobial therapy or cyst drainage. Delay in nephrectomy is associated with increased morbidity and mortality.

- e. **Pyocystis.** In patients with a neurogenic bladder (e.g., diabetic patients), pyocystis (pus in the defunctionalized bladder) may be an unsuspected source of infection. Pyocystis should always be suspected in an anuric dialysis patient with fever of unknown origin. Symptoms can include suprapubic or abdominal pain, foul-smelling urethral discharge, or sepsis. Suprapubic tenderness and a distended bladder may be found on careful examination. A complete peripheral blood count

often shows leukocytosis. Blood cultures may or may not be positive. Bladder catheterization reveals pus, culture of which usually grows a mixed flora. Treatment consists of adequate drainage via an indwelling urethral catheter, followed by intermittent catheterization and bladder irrigations with antimicrobial solutions until the infection clears. Parenteral antimicrobials, chosen according to culture and sensitivity reports, should be administered if systemic manifestations are present. Cystourethroscopy and possibly cystometrography should be performed to rule out a bladder outlet obstruction, a large bladder diverticulum, or a neurogenic bladder. Rarely, surgical drainage procedures or even simple cystectomy may be needed in refractory cases.

2. **Pneumonia.** Pneumonia is an important cause of mortality in this population; the possibility of gram-negative infection should be considered in patients dialyzed in a hospital setting. Dialysis patients may have unusual pulmonary infiltrates due to pulmonary calcification (now uncommon), which can resemble those due to pneumonia. Fluid overload sometimes can be mistaken for pneumonia, and should be suspected, especially when there are bilateral pulmonary infiltrates; such infiltrates can frequently improve after an increase in ultrafiltration. Pleural effusions are commonly exudative in character owing to uremia-associated inflammation, even in the absence of infection.
3. **Intra-abdominal infections.** Diverticulosis and diverticulitis occur commonly in dialysis patients, and especially in those with polycystic kidney disease. Strangulated hernia is also frequently encountered. In peritoneal dialysis patients, the differentiation between dialysis-associated peritonitis and peritonitis due to a disease process involving the abdominal viscera can be difficult (see Chapter 27). Acalculous cholecystitis has been reported. Intestinal infarction can occur as a complication of hypotension occurring during a dialysis session or between dialyses; bowel infarction should always be suspected in a dialysis patient with unexplained, refractory septic shock.
4. **Tuberculosis.** The incidence of tuberculosis has been estimated to be as much as tenfold higher among hemodialysis patients than among the general population. Tuberculosis in hemodialysis patients is frequently extrapulmonary; disseminated disease may occur in the absence of chest x-ray abnormalities. Difficulty in making the diagnosis is increased because delayed skin hypersensitivity to tuberculin reagent is often absent or diminished due to cutaneous anergy. New immunologic tests using interferon-gamma release assays have shown promise in ESKD patients (Segall and Kovic, 2010; Grant, 2012). A number of subtle, atypical presentations of tuberculosis can be encountered; for instance, patients may present with ascites and intermittent fever only, or with hepatomegaly, weight loss, and anorexia. The diagnosis of tuberculosis in extrapulmonary cases is usually made by demonstrating typical caseating granulomas on pleural or hepatic biopsy or by recovery of tubercle bacilli from culture of biopsy material. When the index of suspicion for tuberculosis is high, presumptive therapy with antitubercular agents is sometimes warranted. Mortality in dialysis patients with tuberculosis has been reported to be as high as 40%.
5. **Listeriosis.** Listeriosis, an unusual infection in the nonimmunocompromised host, has been reported to occur in hemodialysis patients suffering from iron overload.

6. *Salmonella* septicemia. In dialysis patients, severe *Salmonella* septicemia has been noted to occur; in nonuremic patients, *Salmonella* enteritis rarely progresses to sepsis.
7. *Yersinia* septicemia. This infection has been reported in iron-loaded dialysis patients receiving deferoxamine chelation therapy.
8. *Mucormycosis*. This sometimes fatal infection is seen with unusual frequency in patients being treated with deferoxamine.
9. *Helicobacter pylori*. Although patients with ESKD frequently have upper GI complications, the prevalence of this infection appears to be the same in ESKD patients as in patients with normal renal function. Therapy is similar to that for nonuremic patients.

IV. VIRAL INFECTIONS

A. **Hepatitis A.** The incidence of hepatitis A in dialysis patients is no greater than in the general population, given that transmission is usually by the fecal–oral route. The disease pursues the usual clinical course in dialysis patients. Chronic hepatitis after hepatitis A infection is believed to occur rarely, if at all.

B. **Hepatitis B**

1. **Epidemiology**

- a. **Hemodialysis patients.** The incidence of infection with hepatitis B virus (HBV) is now quite low in the United States. (Finelli, 2005). The low incidence is due to screening of the blood supply for evidence of this infection and to low transfusion requirements due to the availability of erythropoietin. However, outbreaks of hepatitis B in several hemodialysis units have occurred. Hepatitis B vaccine should be administered to all susceptible hemodialysis patients. Of note, only 50%–60% of vaccinated hemodialysis patients develop a protective antibody response; optimal vaccination techniques are discussed below.
 - b. **Peritoneal dialysis patients.** This group is at very low risk of acquiring hepatitis B infection. Nevertheless, hepatitis B can be transmitted through exposure to peritoneal effluent.
2. **Clinical presentation.** Hepatitis B infection is largely asymptomatic in dialysis patients. Commonly, malaise is the only complaint. The occurrence of visible jaundice is rare. The only manifestation of infection may be an unexplained, mild (two- to threefold) elevation in the serum aspartate (AST) or alanine aminotransferase (ALT) level, or even an increase from a lower to a higher level within the normal range. The serum bilirubin and alkaline phosphatase concentrations may remain normal or be elevated only slightly.
3. **Chronic hepatitis B infection.** Hepatitis B infection in dialysis patients often runs a protracted course and in 50% of cases progresses to a chronic, HbsAg-positive state. Development of clinically important persistent (or active) hepatitis is not nearly as common as it is in nondialysis patients. Patients with high serum ferritin levels appear to be at increased risk for developing persistent hepatitis. Treatment is indicated in HBsAg-positive patients with evidence of viral replication and abnormal transaminase levels, preferably in conjunction with liver histology. A level of 4 to 5 log₁₀ copies/mL

for HBV DNA is usually taken as the threshold to start treatment. It is important to recognize that hepatitis B e antigen (HBeAg) can be negative despite active disease. Interferon, lamivudine, adefovir, or entecavir can be utilized for the treatment of chronic hepatitis B. Entecavir is the recommended first-line therapy in dialysis patients. The doses of all antiviral medications must be adjusted appropriately according to renal function. The dosing for lamivudine, adefovir, and entecavir are 100 mg by mouth daily, 10 mg by mouth daily, and 0.05 mg by mouth daily, respectively. In view of the side effects of interferon in patients on dialysis, nucleotide or nucleoside analogs are better choices.

4. **Routine screening.** Hemodialysis patients should be screened for HBV surface antigen (HBsAg), surface antibody (anti-HBs) and core antibody (anti-HBc) on admission to the dialysis unit (or hospital). HBsAg should then be tested monthly in all HBV-susceptible patients, including nonresponders to the vaccine, and anti-HBs with antibody titer measured annually. Testing for HBV DNA should be done if HBsAg is positive, and may be indicated in patients who are positive for anti-HBc but negative for HBsAg and anti-HBs as such patients can occasionally be infectious.

5. **Prevention**

- a. **Restricting the possibility of exposure to the virus.** Epidemiologic principles can be utilized to decrease the risk of hepatitis B infection, both among patients and among dialysis staff. Table 35.1 lists some helpful precautions. Some centers recommend that patients with hepatitis B antigenemia be treated with either home hemodialysis or home peritoneal dialysis in order to decrease the chance of transmission to other patients and staff.
 - b. **Vaccination.** See Section V below.
 - c. **Hepatitis B immune globulin.** This should be given after any exposure to the body fluids of a person known to be infected with HBV.
- C. **Hepatitis C.** The prevalence of antibodies to hepatitis C virus (anti-HCV) in dialysis patients is higher than in healthy populations. Recent data indicate that 8%–10% of dialysis patients in the United States have anti-HCV. Worldwide, there is considerable variability in the prevalence of anti-HCV, ranging from 1% to 63%. However, there is also great variability in HCV testing practices in dialysis centers (Meyers, 2003). The high incidence and prevalence of HCV infection among dialysis patients can be attributed to several risk factors, including number of blood transfusions, duration of dialysis, mode of dialysis (lower risk in peritoneal dialysis patients), and a history of previous organ transplantation or intravenous drug abuse. Infection rates among dialysis patients in the United States have not changed appreciably since tests for anti-HCV were first developed in the early 1990s. At the present time, there is no evidence that sharing of dialysis machines, type of dialysis membrane used, or dialyzer reprocessing are risk factors. Therefore, the Centers for Disease Control and Prevention (CDC) does not recommend dedicated machines, isolation of patients, or prohibition of reuse in hemodialysis patients with anti-HCV. However, observations suggest both a higher incidence of new cases of hepatitis C in units with a higher prevalence of HCV infection and a decreased incidence of HCV in units that implement infection control measures; therefore, in dialysis units with a high prevalence of

infection, isolation of HCV-positive patients, use of dedicated machines, and restriction on dialyzer reuse for patients infected with HCV may be warranted (Agarwal, 2011). The CDC recommends that all hemodialysis patients should be tested for anti-HCV antibodies on admission, and anti-HCV-negative patients should be tested for anti-HCV antibodies semiannually thereafter.

TABLE

35.1

Infection Control Practices in the Hemodialysis Unit

1. General precautions for staff and patients
 - a. Surveillance for hepatitis B surface antigen (HBsAg) and antibody (HBsAb) (see text)
 - b. Isolation of HBsAg-positive patients (not necessary for human immunodeficiency virus [HIV]- and hepatitis C virus [HCV]-infected patients)
 - c. Cleansing of dialysis machines and blood/body fluid contaminated areas with 1% sodium hypochlorite (bleach) solution
 - d. Dialyzer reuse prohibited for HBV-positive patients (acceptable for patients with anti-HCV and probably HIV)
 - e. Universal precautions (see below)
 - f. Protocol for exposure to blood/body fluids (see below)
2. Universal precautions
 - a. Staff must wear fluid-impermeable garments
 - b. Gloves are to be used whenever there is potential for exposure to blood or body fluids
 - c. Gloves must be changed and hands washed between patients
 - d. Protective eyewear and face shields are worn when there is potential for splashing of blood (e.g., initiation and discontinuation of dialysis, changing the blood circuit)
 - e. No recapping of contaminated needles; prompt disposal in appropriate container
3. Exposure to blood
 - a. Testing for HBsAg and HBsAb at time of incident and 6 weeks later
 - b. Testing for HIV (employee consent required) at time of incident and 6 weeks and 6 months later
 - c. If HBsAg status of source patient is positive or unknown, administer hepatitis B immune globulin
 - d. Test source patient for HIV (inform patient; consent may not be required)

The prevalence of anti-HCV among dialysis staff is similar to that of the general population (0%–6%). Immune globulin and/or α -interferon for postexposure prophylaxis against hepatitis C in health care workers are not recommended.

The natural history of hepatitis C in dialysis patients is difficult to ascertain since there have been no large studies in which liver biopsy was performed. The association between liver enzymes (e.g., ALT) and histologic severity is poor. Multivariate analyses have shown an increased risk of death in hepatitis C–infected patients, with excess mortality predominantly due to cirrhosis and liver cancer.

Until very recently (Gentile, 2014), treatment options were suboptimal. α -Interferon results in decreased transaminase levels and improved liver histology in most patients, with a sustained response in about 40% of patients, a response rate at least comparable to that seen in patients without renal disease. However, the incidence of side effects is substantial. Common side effects are myalgias, headache, fatigue, and depression, but more serious adverse effects, including bone marrow suppression, pancreatitis, cardiac failure, and lymphoma, have been reported. Therefore, the benefit-to-risk ratio in the dialysis population is unclear. Treatments with interferon (IFN- α 2a) and pegylated IFN achieve a cure rate of 30%–45% in this population. Addition of ribavirin may increase the cure rate, but is tolerated poorly in ESKD patients (Esforzado and Campistol, 2012). Ribavirin is normally renally excreted and causes dose-related hemolysis; therefore, it must be used with extreme caution and at a reduced dose in dialysis patients.

Treatment for hepatitis C should at present be considered only for patients with significant liver disease with a reasonable likelihood of prolonged survival, especially in patients in whom transplantation is planned. A recent meta-analysis found that dose of IFN ($\geq 3 \times 10^6$ thrice weekly), treatment for ≥ 6 months, treatment completion, lower baseline HCV RNA, female gender, and early virologic response were predictive of sustained virologic response (Gordon, 2009). 2008 KDIGO guidelines recommend monotherapy with standard IFN that is dose adjusted for a glomerular filtration rate (GFR) < 15 mL/min per 1.73 m². A possible regimen is 3 million units of IFN α -2b administered subcutaneously three times per week for 6 to 12 months (if tolerated). Close observation for significant side effects is mandatory.

The recent high cure rates achieved with new interferon-free drug regimens using combinations of direct-acting antiviral agents such as daclatasvir, asunaprevir, dasabuvir, sofosbuvir, and ABT-450/r-ombitasvir with or without ribavirin has markedly enhanced the chances for cure of hepatitis C infection in nondialysis patients (Chung and Baumert, 2014; Gentile, 2014). There is very limited experience with any of these new drug combinations in dialysis patients, although many of these drugs are primarily excreted by the liver. Some time will be needed to see how and to what extent these very new major advances against hepatitis C infection can be applied to the ESKD population.

- D. **Cytomegalovirus (CMV) and mononucleosis.** These viral infections can mimic hepatitis due to B or C virus but occur uncommonly in dialysis patients.
- E. **Influenza.** Dialysis patients are at increased risk for developing complications during influenza infection and should be vaccinated. Use of antiviral agents for influenza prevention and treatment is discussed below.
- F. **Human immunodeficiency virus (HIV)**
 1. **Incidence and prevalence.** The rate of HIV infection in hemodialysis patients is elevated, but only slightly above that in the general population. The incidence of HIV infection in the U.S. ESKD program is stable. Both incidence and prevalence are much higher in large urban areas serving minorities.
 2. **Clinical manifestations.** Dialysis patients who are HIV positive may be asymptomatic or may present with the full-blown acquired immunodeficiency syndrome (AIDS). HIV-related renal disease may be an important cause of renal failure in some patients. Since

the availability of highly active antiretroviral therapy (HAART), the prognosis of HIV-infected patients has markedly improved, and many patients who are HIV positive without other clinical manifestations can live for many years on dialysis.

3. **Routine screening.** There exists some controversy as to whether hemodialysis patients without clinical evidence of AIDS should be routinely screened for HIV positivity. The recommendation from the CDC is that routine screening not be performed. However, some dialysis units (especially those serving high-risk populations) are screening for HIV. Issues of confidentiality must be balanced against the risk to other patients and dialysis staff.
4. **Dialysis in patients who are HIV positive.** The CDC recommendation is that the choice between hemodialysis and peritoneal dialysis should not be affected by the finding of HIV positivity. However, home dialysis will lessen any possible risk to other patients and to dialysis staff. The peritoneal effluent of HIV-positive patients should be considered infectious and handled appropriately. If hemodialysis is elected, the CDC guidelines maintain that only the usual body fluid precautions attendant to routine dialysis need be followed. The CDC does not recommend that a special dialysis machine be set aside for HIV-positive patients, and dialyzer reuse in HIV-positive patients is not forbidden.

A number of dialysis units see the CDC recommendations as too liberal and are treating HIV-positive patients in the same manner as patients who are Hb_sAg positive (see Table 35.1). Health care workers have developed HIV infection after skin or mucous membrane contact with HIV-infected blood, underscoring the importance of universal precautions while performing dialysis.

V. **VACCINATION.** In dialysis patients, the antibody response to a number of commonly used vaccines is suboptimal. Nevertheless, vaccination against pneumococcus, influenza, and hepatitis is believed to be indicated for almost all dialysis patients. Table 35.2 lists the recommended frequency of administration of commonly used vaccines. For all vaccines other than hepatitis B, the dosages are identical to those used in the general population.

- A. **Vaccination against hepatitis B.** All dialysis patients except those who are HbsAg or HbsAb (antibody) positive should receive the hepatitis B vaccine. To increase the chances of successful vaccination, the dosage of hepatitis B vaccine in dialysis patients should be twice the normal amount. Giving an additional dose, especially if there is a fall in antibody titer below 10 mIU/mL, is recommended. A series of four IM injections of 40 mcg HbsAg should be given into the deltoid muscles at intervals of 0, 1, 2, and 6 months to complete the primary immunization series. Injection into the gluteal muscle is not recommended because gluteal injection has been associated with failure to develop antibody or with loss of antibody 6 months to 1 year following immunization (in nonuremic as well as in uremic patients).

Vaccine	Frequency of Administration
Influenza A and B	Annually
Tetanus, diphtheria	Booster every 10 years
Pneumococcus	Revaccination dependent on antibody response
Hepatitis B	For initial vaccination schedule give a total of four double doses with each injection split between the left and right deltoid muscles Requirement for revaccination not yet known, but recommended if there is a fall in antibody titer (see text)

Overall, the percentage of successful vaccination against hepatitis B in dialysis patients is less than in the general population, and rates as low as 50%–60% have been reported. Some patients may not have responded because of gluteal vaccine administration or because of failure to complete the vaccination regimen. The usefulness of adjuvant vaccines and vaccines given intradermally continues to be studied (Fabrizi, 2011).

VI. ANTIMICROBIAL USAGE IN DIALYSIS PATIENTS. Table 35.3 lists dosing guidelines for most commonly used antimicrobial, antifungal, and antiviral agents in patients treated with intermittent hemodialysis and peritoneal dialysis. Due to increased efficiency of drug removal in continuous renal replacement therapy (CRRT), optimal dosing strategies for antimicrobials in CRRT differ from traditional dialysis dosing. Additional dosing recommendations for drugs studied in CRRT are provided in Chapter 15.

A. Penicillins. Most penicillins are normally excreted by the kidney to a substantial extent (40%–80%), and are removed to a moderate degree by both hemodialysis and peritoneal dialysis. Therefore, both dosage reduction and posthemodialysis supplementation are generally recommended. From a practical standpoint, postdialysis supplementation is probably unnecessary; however, dosing should be timed so that a dose is given immediately after dialysis. Two exceptions to this general rule are nafcillin and oxacillin; because these drugs are substantially excreted by both the liver and the kidney, dosage reduction is not necessary unless liver function is also impaired. Because of the high therapeutic index of penicillins, monitoring of serum levels is generally not necessary.

Amoxicillin-clavulanate, ticarcillin-clavulanate, piperacillin-tazobactam, and ampicillin-sulbactam are examples of penicillins combined with β -lactamase inhibitors. β -lactamase inhibitors slow the breakdown of β -lactams by bacteria exhibiting resistance to penicillins. The β -lactamase inhibitor of these combination drugs may exhibit longer half-lives in ESKD. Clavulanate is a β -lactamase inhibitor that is frequently combined with amoxicillin or ticarcillin. The half-life of clavulanate increases from 0.75 to about 5.0 hours with renal failure, but clavulanate is dialyzable. The dosing recommendations for the parent antimicrobial in Table 35.3 will usually apply as well to the antimicrobial-clavulanate combination.

Drug	Usual Nonuremic Dose ^a	Half-life		Dialysis Patient Dose (%)	Usual Dialysis Patient Dosage	Post-HD Supplement	Dosage for CAPD ^b
		Nonuremic Patient	(hr)				
Antibiotics							
Penicillins							
Amoxicillin PO	250–500 mg q8h	0.7–1.4	7–21	50–80	250–500 mg q24h	DAD	250–500 mg q12h
Ampicillin IV	1–2 g q4–6h	1–1.8	7–20	50–80	1–2 g q12–24h	DAD	250 mg q12h
Ampicillin/sulbactam IV	1.5–3 g q6h	See ampicillin			1.5–3 g q12–24h	DAD	3 g q24h
Dicloxacillin PO	125–500 mg q6h	0.6–0.8	1.3	95–100	250 mg q6h	No	Same
Nafcillin IV	1–2 g q4h	0.5–1	1.2	100	1–2 g q4h	No	Same
Oxacillin IV	0.5–1 g q4–6h	0.3–1	0.3–1.0	95–100	0.5–1.0 g q4–6h	No	Same
Penicillin G IV/IM ^c	0.5–4 mU q4h	0.5–0.84	3.3–5.1	25–50	0.5–1 mU q4–6h or 1–2 mU q8–12h	DAD	Same
Penicillin V PO	250 mg q6h	0.5	4.0	50	250 mg q12h	No	Same
Piperacillin IV	3–4 g q4–6h	1.0	3.3–5.1	50–70	2 g q8h	1g	3–4g q8h
Piperacillin/tazobactam IV	3.375–4.5 g q6–8h	See piperacillin			2.25 g q12h, for HAP 2.25 g q8h	0.75 g	Same
Ticarcillin/clavulanate IV	3.1 g q4–6h	1.1	12	50–80	2 g (ticarcillin) q12h or 2 g q8h without supplemental dose	3.1 g	3.1 g q12h
Cephalosporins							
Cefaclor PO	0.25–0.5 g q8h	0.5–1	2.8	50–80	250 mg q12h	250 mg	Same
Cefadroxil PO	0.5–1 g q12h	1.4	22	25–50	1–2 g q36h	0.5–1 g	Same
Cefazolin IV/IM	1–2 g q8h	2	40–70	50–80	0.5–1 g q24 or 1–2 g q48–72h	0.5–1 g	0.5 mg q12h
Cefdinir PO	600 mg q.d. or 300 mg q12h	1.7	?	?	300 mg q48h	300 mg	?
Cefepime IV	1–2 g q8–12h	2	13.5	25	1 g q24h × 1 then 1–2 g q48–72h or 2 g t.i.w.	DAD	1–2 g q48h
Cefotaxime IV	1–2 g q4–12h	1–1.5	15–35	50	1–2g q24h	DAD	1g q24h
Cefotetan IV/IM	1–2 g q12h	3–5	13–25	80–95	0.25–0.5 g q24h on non-dialysis days	1g	1 g q24h
Cefoxitin IV/IM	1–2 g q6–8h	0.6–1	13–23	15	0.5–1 g q12–48h	1–2 g	1g q24h
Cefpodoxime PO	100–400 mg q12h	2.2	9.8	25	100–400 mg t.i.w.	DAD	100–400 mg q24h
Cefprozil PO	500 mg q24h or 250–500 mg q12h, or 250 mg t.i.d.	1.3	6.0	45	250 mg q24h	DAD	?
Ceftaroline IV	600 mg q12h	2.7	?	33	200 mg q12h	DAD	?
Ceftazidime IV/IM	2 g q8h	1–2	13–25	0–50	0.5–1 g q24h or 1–2 g q48–72h	1 g ^d	1 g load then 500 mg q24h
Ceftibuten PO	400 mg q24h	2	13–22	25–50	400 mg or 9 mg/kg (after each dialysis session)	DAD	?
Ceftriaxone IV	1–2 g q12–24h	5–9	12–16	100	1–2 g q12–24h	None	Same
Cefuroxime IV	0.75–1.5 g q8h	1–2	17	75	0.75–1.5 g q24h	DAD	Same
Cefuroxime PO	250–500 mg q12h	1–2	17	33	?	?	?
Cephalexin PO	0.25–1.0 g q6h	0.5–1.2	30	50–80	250 mg q12–24h	DAD	Same
Carbapenems/monobactams							
Aztreonam IV	1–2 g q6–8h	1.7–2.9	6–8	50–80	LD of 0.5, 1, or 2 g then 0.25–0.5 g q6–8h; or 500 mg q12h	for severe infections 125–250 mg after dialysis	Same
Doripenem IV	500 mg q8h	1.0	18	48	250 mg q24h, for PSA 500 mg q12h (on day 1) then 500 mg q24h	?	?
Ertapenem IV/IM	1 g q24h	4.0	>4.0	50	500 mg q24h	150 mg ^f	500 mg q24h
Imipenem/cilastin IV/IM	0.5 q6h	1.0	4	50	250–500 mg q12h	DAD	Dosed by weight
Meropenem IV	0.5–2 g q8h	1–1.5	6–8	25	500 mg q24h	DAD	0.5–2 g q24h
Fluoroquinolones							
Ciprofloxacin IV	400 mg q12h	3–5	6–9	90–100	200–400 mg q24h	?	?
Ciprofloxacin PO	IR 500–750 mg q12h; ER 500–1,000 mg q24h	3–5	6–9	90–100	IR 250–500 mg q24h; ER 500 mg q 24h	DAD	Same
Gemifloxacin PO	320 mg q24h	4–12	>7		160 mg q24h	DAD	Same
Levofloxacin IV/PO	750 mg q24h	6–8	76	25	750 mg once then 500 mg q48h	DAD	Same
Moxifloxacin IV/PO	400 mg q24h	8–15 (IV) 12–16 (PO)	9–16	100	400 mg q24h	No	Same
Ofloxacin IV/PO	200–400 mg q12h	4–5, then 20–25	28–37	25	100–200 mg q24h	DAD	300 mg q24h
Aminoglycosides							
Amikacin IV	5–7.5 mg/kg q12h	1.4–2.3	28–86	80	See text	See text	See text
Gentamicin IV	1–2.5 mg/kg q8–12h	1.5–3	36–70	50	See text	See text	See text
Neomycin PO	0.5–2 g q6–8h	Avoid in renal failure					
Streptomycin IM	15–30 mg/kg q24h	5	30–80	15	7.5–15 mg/kg t.i.w. on dialysis days	DAD	See text
Tobramycin IV	1–2.5 mg/kg q8–12h	2–3	5–70	30–75	1–2 mg/kg q48–72h	See text	See text
Macrolides and ketolides							
Azithromycin IV/PO	500 mg q24h × 1 d, 250 mg q24h × 4 d	68–72	?	100	500 mg q24h × 1 d, 250 mg q24h × 4 d	No	Same

Clarithromycin PO	250–500 mg q12h	3–7	?	50	250 mg q12h	DAD	?
Erythromycin IV/PO	250–500 mg q6–12h	1.5-2	5–6	80–95	250–500 mg q6–12h	No	Same
Telithromycin PO	800 mg PO q24h	10	15		600 mg q24h	DAD	?
Glycopeptides							
Telavancin IV	10 mg/kg q24h	6.6–9.6	?	?	?	?	?
Vancomycin IV	15–20 mg/kg q12h	5–11	200–250	<10	1 g q4–7 d	See text	See text
Tetracyclines							
Demeclocycline PO	150 mg q6h or 300 mg q12h	Avoid in renal failure					
Doxycycline IV/PO	100–200 mg q12–24h	12–15	18–25	100	100–200 mg q12–24h	No	Same
Minocycline IV/PO	200 mg LD, 100 mg q12h	11–22	?	100	100 mg PO q12h	No	Same
Tetracycline PO	250–500 mg q6h	8–11	57–108	80–95	?	No	?
Nitroimidazoles							
Metronidazole IV/PO	500 mg q6–8h	8	18–32	0–50	500 mg q8–12h	DAD	250 mg q6–8h or 500 mg q12h
Tinidazole PO	2g q24h	13	11.1–14.7	100	2 g q24h	1g	?
Diaminopyrimidines							
Pyrimethamine PO	25–50 mg q24h	80–95		100	25–50 mg q24h	No	?
Trimethoprim (T)/sulfameth-oxazole(S) IV/PO	See text	8–10 (T)	26 (T)	50	See text	See text	See text
Antituberculars							
Ethambutol PO	15 mg/kg q24h	2.5–3.6	7–15	50	15 mg/kg q48h or 15 mg/kg t.i.w.	DAD	Same
Isoniazid IV/PO	300 mg q24h	0.5–1.5 (fast acetylators) 2.5–3.6 (slow acetylators)	2.3 7–15	100 ^f	300 mg q24h	DAD	Same
Pyrazinamide PO	15–30 mg/kg/d	9–10	?	50	25–35 mg/kg t.i.w.	DAD	?
Rifabutin PO	300 mg q24h	45	ND	50	150 mg q24h	?	?
Rifampin IV/PO	600 mg q24h	3.5	4.0	100	600 mg q24h	No	Same
Miscellaneous antibiotics							
Colistin	1.25–2.5 mg/kg q12h	2–3	48–72		1.5 mg/kg q24–48h	DAD	?
Clindamycin PO	150–450 mg q6h	2–3, 3.4–5.1 (elderly)	4.0	100	Same	No	Same
Clindamycin IV	600–900 mg q8h	2.3, 3.4–5.1 (elderly)	4.0	100	400–900 mg q8h	No	Same
Dapsone PO	50–100 mg q24h	10–50		100	Pneumocystis pneumonia prophylaxis 50 mg q12h	DAD	?
Daptomycin IV	4–6 mg/kg q24h	8–9	30	50	4–6 mg/kg q48h ^f or 6 mg/kg t.i.w. after dialysis	DAD	Same
Linezolid IV/PO	600 mg q12h	4–5	6–8	70	600 mg q12h	DAD ^p	Same
Methenamine PO	1 g q6h (mandelate) 1 g q12h (hippurate)	Avoid in renal failure					
Nitrofurantoin PO	50–100 mg q6h	Avoid in renal failure					
Quinupristin/Dalfopristin IV	7.5 mg/kg q8–12h	1.3–1.5	?	100	7.5 mg/kg q8–12h	No	Same
Spectinomycin IM	2–4 g once	1.2–2.8	4.7–29.3	50	2–4 g once	No	Same
Antivirals							
Acyclovir IV	5–10 mg/kg q8h	3.0	19.5	15–20	2.5–5 mg/kg q24h	DAD	Same
Acyclovir PO	200–800 mg 5x/day	3.0	19.5	15–20	200 mg q12h	DAD	Same
Amantadine PO	100 mg q12h	24	168–240	<10	200 mg q wk ^g	No	Same
Boceprevir	300 mg t.i.d.	3	3	100	300 mg t.i.d.	No	Same
Cidofovir IV	5 mg/kg weekly to every other week	Contraindicated with creatinine clearance ≤55 mL/min or serum creatinine >1.5 mg/dL					
Famciclovir PO	125–500 mg q8–12h	2–4	3–24	25	125–250 mg t.i.w.	DAD	?
Foscarnet IV	60 mg/kg q8h × 3 wk, then 90–120 mg/kg q24h	3.0	?	50–100	45–90 mg/kg t.i.w.	DAD	?
Ganciclovir IV	5 mg/kg/d q12–24h	1.7–5.8	5–28	25	0.625–1.25 mg/kg/dose t.i.w.	DAD	Same
Oseltamivir PO	75 mg b.i.d.	6–10	No data	<20	75 mg t.i.w.	DAD	30 mg q7d
Ribavirin PO	800–1,200 mg in two divided doses daily	24 (capsule), 120–170 (tablet)	?	50	200 mg q24h	No	Same
Rimantidine PO	100 mg q12h	25	40	50	100 mg q24h	No	Same
Valacyclovir PO	1–2 g q 8–12h	3.0	14	16	500 mg q24h	DAD	Same
Valganciclovir PO	900 mg q12–24h	Avoid in patients receiving hemodialysis					
Zanamivir PO	10 mg b.i.d.	2.5–5	18.5	100	10 mg b.i.d.	No	Same
Antiretrovirals							
Abacavir PO	300 mg q12h or 600mg q24h	1–1.5	?	100	300 mg q12h	No	?
Adefovir PO	10 mg q24h	7.5	15	10–30	10 mg q7d	DAD	?
Atazanavir PO	300–400 mg q24h	7.0	?	97.9	300 q24h ^h	?	?

Darunavir	800 mg q24h	15	?	43	?	?	?
Delavirdine PO	400 mg q8h	5.8	?	100	?	?	?
Didanosine PO	25–60 kg: 200 mg q24h > 60 kg: 400 mg q24h	1.3–1.5	2.5–5	65–80	<60 kg: capsule not recommended >60 kg: 25 mg q24h	No	Same
Entecavir PO	0.5–1 mg q24h	128–149	?	87	0.05–0.1 mg q24h	DAD	Same
Efavirenz PO	600 mg q24h	40–55	?	100	?	?	?
Elvitegravir/cobicistat/ emtricitabine/tenofovir PO	1 tab q24h	4–13	?	?	Avoid in patients receiving dialysis		
Enfuvirtide SC	90 mg q12h	3.8		100	90 mg q12h	No	?
Emtricitabine PO	Capsule 200 mg q24h; Solution 240 mg q24h	10	>10	70	Capsule 200 mg q96h; Solution 60 mg q24h	DAD	?
Fosamprenavir PO	1400 mg q24h	7.7	?	?	1400 mg q24h	?	?
Indinavir PO	800 mg q8h	1.4–2.2	?	100	?	?	?
Lamivudine PO	150 mg q12h or 300 mg q24h	3–7	15–35	76	50 mg LD, then 25 mg q24h	No	Same
Lopinavir/ritonavir PO (1 tablet = 200 mg lopinavir and 50 mg ritonavir)	2 tablets q12h	3.67		100	2 tablets q12h	No	?
Maraviroc PO	300 mg q12h	14–18	?	100	300 mg q12h	?	?
Nelfinavir PO	1250 mg q12h or 750 mg q8h	3.5–5	?	100	1250 mg q12h	?	Same
Nevirapine PO	200 mg q12h	25–30	?	56	?	200 mg	?
Raltegravir PO	400 mg q12h	9	?	100	400 mg q12h	DAD	?
Rilpivirine PO	25 mg q24h	50	?	100	25 mg q24h	No	Same
Ritonavir PO	600 mg q12h	3–5	?	100	?	?	?
Saquinavir	1000 mg b.i.d. with 100 mg ritonavir b.i.d.	13	?	100	?	?	?
Stavudine PO	≥60 kg: 40 mg q12h <60 kg: 30 mg q12h	1.6	1.55–5.4	69	≥60 kg: 20 mg q24h <60 kg: 15 mg q24h	DAD	?
Telaprevir PO	1125 mg q12h	4–11			?	?	?
Telbivudine PO	600mg q24h	40–49	?		600 mg q96h	DAD	?
Tenofovir PO	300 mg q24h	17	?	90?	300 mg q7d	DAD	?
Tipranavir PO	500 mg q12h	5.5–6	?	100	500mg q12h	?	?
Zidovudine PO	300 mg q12h	1.0	1.4	See text	100 mg q6–8h		Same
Antifungals							
Amphotericin B cholesteryl sulfate complex (Amphotec)	3–4 mg/kg/d	28	?	100	?	?	?
Amphotericin B lipid complex (Abelcet IV)	5 mg/kg q24h	173 (after multiple doses)	?	100	5 mg/kg q24h	No	Same
Amphotericin B liposome (AmBisome IV)	3–6 mg/kg q24h	7–10 (after a single 24h dosing interval)	?	100	3–6 mg/kg q24h	No	Same
Anidulafungin IV	100–200 mg day 1, then 50–100 mg q24h	40–50	?	100	100–200 mg day 1, then 50–100 mg q24h	No	?
Caspofungin IV	70 mg LD, 50 mg q24h	9–11	?	100	70 mg LD, 50 mg q24h	No	Same
Fluconazole IV/PO	150–800 mg q24h	30	?	100	200–800 q24h	DAD	?
Flucytosine PO	50–150 mg/kg/d in divided doses q6h	2–5	75–200	10–25	37.5 mg/kg q24–48h	DAD	0.5–1.0 g q24h
Griseofulvin PO (microsize)	500 mg q24h	9–24	?	100	?	?	?
Griseofulvin PO (ultramicrosize)	375–750 mg q24h	9–24	?	100	?	?	?
Itraconazole PO capsule	200–600 mg in divided doses daily	21	?	100	200–400 mg in divided doses daily	No	?
Itraconazole PO suspension	100–200 mg q24h	21	?	100	?	?	?
Ketoconazole PO	200–400 mg q24h	8.0	8.0	100	200–400 mg q24h	No	?
Micafungin IV	50–150 mg q24h	11–21	?	100	50–150 mg q24h	No	?
Posaconazole PO Delayed-release tablet	300 mg q12h or q24h	26–31	?	100	300 mg q12h or q24h	No	?
Posaconazole PO Oral Suspension	100–400 q12h or q24h or 200 mg q8h Depends on indication	20–66	?	100	100–400 q12h or q24h or 200 mg q8h	No	?
Posaconazole IV	300 mg q 12–24h	Not recommended in patients with creatinine clearance ≤50 mL/min or <18YOA					
Terbinafine PO	250 mg q24h	Not recommended in patients with creatinine clearance ≤50 mL/min					
Voriconazole IV	6 mg/kg q12h LD, 4 mg/kg q12h	Not recommended in patients with creatinine clearance ≤50 mL/min					
Voriconazole PO	≥40 kg: 200 mg q12h <40 kg: 100 mg q12h	Variable and dose dependent		100	≥40 kg: 200 mg q12h <40 kg: 100 mg q12h	No	Same

DAD, no post-HD supplement required, but on hemodialysis days schedule the usual dialysis patient dose after the dialysis session; HD, hemodialysis; CAPD, continuous ambulatory peritoneal dialysis; IM, intramuscular; IV, intravenous; LD, loading dose; PD, peritoneal dialysis (primarily CAPD); PO, oral; SC, subcutaneous; q24h, daily; q.h.s., at bedtime; t.i.d., three times/d; b.i.d., two times/d; t.i.w., three times per week.

^a Usual doses recommended for treatment of moderate-to-severe infections.

^b Same as usual dialysis patient dosage.

^c Doses greatly vary based on indication.

^d Prolonged half-life allows dosing thrice weekly post-HD.

^e Supplemental dose may be considered early in treatment course.

^f No dosage reduction needed in patients known to be fast acetylators.

^g Long-term administration best avoided unless blood levels are followed.

^h Recommended only in antiretroviral treatment-naïve patients as boosted therapy with ritonavir 100 mg once daily.

ⁱ If next planned dialysis is >72 hr away, give 9mg/kg.

^j If dosed <6 hr prior to HD give 150mg AD.

Sources: Lexi-Drug, Lexi-Comp[®] [Internet database]. Hudson, OH: Lexi-Comp, Inc. Available at <http://www.crlonline.com>. Accessed April 10, 2014. Data from Facts and Comparisons. Available from <http://online.factsandcomparisons.com>. Accessed April 23, 2013. Up to date. Available from <http://www.upToDate.com/contents/search>. Accessed April 23, 2013. Micromedex. Available from <http://www.micromedex.com/index.html>. Accessed April 23, 2013. *The Sanford guide to antimicrobial therapy 2012*. 42nd ed. Antimicrobial Therapy Inc., Sperryville, VA, 2012; McNeil-Hill IR, Rodriguez RA. Dosing of Antiretroviral Drugs in Adults with Chronic Kidney Disease and Hemodialysis. HIVinstitute. Available at: <http://hivinstitute.ucsf.edu/institute?page=md-rr-18> Accessed May 10, 2013; Heintz BH, Matzke GR, Dager WE. Antimicrobial dosing concepts and recommendations for critically ill adult patients receiving continuous renal replacement therapy or intermittent hemodialysis. *Pharmacotherapy*. 2009;29:562–577; Stathoulopoulou F, et al. Clinical pharmacokinetics of oral acyclovir in patients on continuous ambulatory peritoneal dialysis. *Nephron*. 1996;74:337. Stanford Hospital and Clinics Antimicrobial Dosing Reference Guide 2013. Available at <http://bugsanddrugs.stanford.edu/documents/2013SHCAntiDosingGuide.pdf>. Accessed April 10, 2014.

Ticarcillin is no longer available without clavulanate in the United States or the United

Kingdom. The recommended dose for ticarcillin-clavulanate in patients on hemodialysis is 2 g of ticarcillin component every 12 hours; supplemented with 3.1 g (ticarcillin/clavulanate) after each dialysis session. Alternatively, 2 g every 8 hours can be given without a supplemental dose for severe infections (Heintz, 2009). In CRRT, ticarcillin-clavulanate should not be administered in intervals exceeding every 8 hours. The clavulanate component is hepatically eliminated, and extending the dosing interval beyond 8 hours may result in loss of beta-lactamase inhibition (Trotman, 2005). In patients weighing less than 60 kg, ticarcillin-clavulanate dosing is weight based.

In renal failure, tazobactam accumulates proportionally to piperacillin, and dosing is based on the optimal piperacillin dose. Piperacillin-tazobactam should be dosed more frequently (2.25 g every 8 hours) for nosocomial pneumonia in patients on hemodialysis. Piperacillin-tazobactam is cleared by all forms of CRRT. In CH (continuous hemofiltration) the recommended dose is 2.25–3.375 g every 6–8 hours and in CHD (continuous hemodialysis) the dose is slightly higher: 2.25–3.375 g every 6 hours. Treatment of resistant pathogens, such as *Pseudomonas*, requires higher doses, and an alternate dosing of 4.5 g every 8 hours has been recommended. In CRRT, there is some concern of tazobactam accumulation, given its lower clearance relative to piperacillin, and using piperacillin alone to alternate with piperacillin-tazobactam, particularly in CH-dependent patients, may minimize this concern. Ampicillin-sulbactam has similar pharmacokinetics to piperacillin-tazobactam, and dose adjustments are similar.

- B. **Cephalosporins.** Ceftriaxone is the only cephalosporin that is both highly protein bound and hepatically metabolized; thus no dosing adjustment is required in dialysis patients. The remaining cephalosporins are excreted by the kidney to a large extent (e.g., 30%–96%), and most are removed to some extent by dialysis; therefore, dosage reduction is almost always necessary for dialysis patients. Some of the long-acting cephalosporins (e.g., cefazolin, ceftazidime) can be administered thrice weekly (e.g., after each hemodialysis session in patients being dialyzed three times a week). In patients on intermittent hemodialysis, cefotetan should be administered at 25% of the usual dose every 24 hours on days between dialysis and 50% of the usual dose on the day of dialysis.

Cefepime at a higher dose of 4 g per day can be considered to treat *Pseudomonas* or life-threatening infections in order to maximize time above the minimum inhibitory concentration (MIC) (Trotman, 2005). Cefepime doses of 1 g every 8 hours achieve similar steady-state concentrations as 2 g every 12 hours at lower costs (Heintz, 2009). Doses of 2 g every 8 hours may be needed to treat infection with gram-negative rods showing an MIC ≥ 4 mg/L (Heintz, 2009). Ceftaroline is the newest fifth generation cephalosporin and is the only cephalosporin with some activity against MRSA. It is approved for treatment of skin and soft tissue infections as well as community-acquired pneumonia. Like others in its class, it is renally cleared and requires a significant dose reduction in ESKD.

Cephalosporins in CHD or CHDF (continuous hemodiafiltration) should be dosed according to the dosing recommendations for patients with a CrCl of 30–50 mL/min. Studies with ceftazadime appear to suggest CH does not remove cephalosporins as efficiently as CHD (Trotman, 2005). In CHDF, ceftazadime may be given with a 2-g loading dose followed by 3 g over 24 hours as a continuous IV infusion to maintain

concentrations \geq four times the MIC for susceptible pathogens (Heintz, 2009). Not all cephalosporins have been studied in CRRT; however, extrapolations on dosing can be made based on antibiotics of similar pharmacokinetic and molecular properties.

- C. **Carbapenem/monobactams.** Imipenem is available with cilastatin as a 1:1 dosage ratio between the two compounds. Cilastatin is an inhibitor of the renal dipeptidase enzyme that rapidly breaks down imipenem. Cilastatin accumulates more than imipenem in patients with renal failure. The half-life for cilastatin is prolonged from 1 hour to about 15 hours in renal failure, but cilastatin is dialyzable. In CRRT, imipenem/cilastatin doses of 250 mg every 6 hours or 500 mg every 8 hours are recommended, while higher doses of 500 mg every 6 hours may be required for more resistant infections (Trotman, 2005).

Ertapenem, meropenem, and doripenem are resistant to renal degradation and are not given with an adjunctive dipeptidase inhibitor. Ertapenem has a broad spectrum of activity, covering the gram-positives, gram-negatives, and anaerobes. Unlike the other carbapenems, ertapenem lacks coverage against *Pseudomonas* and *Acinetobacter*. Ertapenem has the advantage of once-daily dosing. The dose should be reduced by 50% in patients with renal dysfunction. Meropenem has similar coverage to imipenem/cilastatin, and doses of 500–1,000 mg every 12 hours are recommended in CRRT. Doripenem is the newest carbapenem, and 52% is removed during a 4-hour hemodialysis session in ESKD patients. The recommended dose with intermittent hemodialysis is 250 mg every 24 hours; however, when treating *Pseudomonas*, the recommended dose is 500 mg every 12 hours on day 1, followed by 500 mg every 24 hours.

Aztreonam is the sole monobactam antibiotic in its class with gram-negative coverage only (including coverage of *Pseudomonas*). Owing to the cost of aztreonam, this antibiotic is typically reserved for patients who have a history of rash to both penicillins and cephalosporins, or patients who have an immediate-type allergy (i.e., anaphylaxis) to the penicillins. For patients receiving dialysis, a loading dose of 500 mg, 1 g, or 2 g, followed by 25% of the initial dose at the usual interval (every 6–8 hours) should be given. For serious/life-threatening infections, administer 12.5% of the initial dose after each dialysis session (given in addition to the maintenance doses). Alternatively, aztreonam can be dosed 500 mg every 12 hours in patients on hemodialysis (Heintz, 2009).

- D. **Fluoroquinolones.** Moxifloxacin has better coverage against gram-positive pathogens (particularly *Streptococcus pneumoniae*) versus the older fluoroquinolones. The majority of the fluoroquinolones can be administered both orally and intravenously. Moxifloxacin is the only antibiotic in this class that does not require dosage adjustment with intermittent hemodialysis or CRRT. Levofloxacin is removed by CH and CHDF but not intermittent hemodialysis. Higher doses of ciprofloxacin may be required for CRRT. Ciprofloxacin also comes as an extended-release oral formulation that is dosed once daily, is not interchangeable with immediate-release formulations, and is approved only for UTI. Oral and IV formulations of gatifloxacin were discontinued in 2006 owing to the risk of profound hypoglycemia.
- E. **Colistimethate.** Colistimethate (Colistin) was largely supplanted by aminoglycosides 30 years ago owing to its high risk of dose-dependent nephrotoxicity and neurotoxicity. Recent reports indicate that the incidence of acute kidney injury with colistin can be as high as

60% (Kubin, 2012). However, colistin is one of the few drugs that can still have activity against multidrug-resistant gram-negative organisms such as *Pseudomonas* and *Acinetobacter*. It is a large, highly tissue-bound molecule, and dialytic removal is small. Doses should be based on ideal body weight in obese patients, and recommended doses are expressed in terms of colistin base. In CRRT, colistin can be dosed at 2.5 mg/kg every 48 hours; however, a single case report has demonstrated that the use of 2.5 mg/kg every 48 hours with a dialysate flow rate of 1 L/hour may be inadequate and that dosing every 24 hours was well-tolerated. Based on pharmacokinetic analysis, dosing as frequent as every 12 hours can be recommended in patients receiving CHDF (Li, 2005). Colistin also comes in nebulized inhalation form that can be used for bronchiectasis and pulmonary colonization/infection in patients with cystic fibrosis.

F. **Aminoglycosides.** Renal excretion of aminoglycosides is normally > 90%, and a substantial increase in dosing interval is necessary in patients with renal dysfunction. Drug removal by dialysis is around 50%, requiring a postdialysis supplement or addition of aminoglycoside to peritoneal dialysis solutions. The therapeutic index of these agents is low, with the major risk (in dialysis patients) being otovestibulotoxicity. Loss of clinically important residual renal function may also occur. High-dose extended interval dosing is not recommended in patients with ESKD. Dosing for all aminoglycosides is based on ideal body weight and adjusted body weight for obese patients.

1. **Gentamicin and tobramycin**

a. **Hemodialysis patients.** In patients receiving hemodialysis three times a week, a loading dose of 2–3 mg/kg is recommended followed by maintenance doses according to indication as follows: For mild UTI or synergy (making use of a synergistic effect of aminoglycoside with other concomitantly administered antibiotics), 1 mg/kg every 48–72 hours is recommended and redosing for prehemodialysis or posthemodialysis concentrations <1 mg/L should be considered. For moderate-to-severe UTI, 1–1.5 mg/kg every 48–72 hours is recommended, and redosing for prehemodialysis concentrations <1.5–2 mg/L or posthemodialysis concentrations <1 mg/L should be considered. For systemic gram-negative rod infection, 1.5–2 mg/kg every 48–72 hours and redosing for prehemodialysis concentrations <3–5 mg/L or posthemodialysis concentrations <2 mg/L is recommended. Although removal of gentamicin and tobramycin is primarily renal, extrarenal excretion of up to 20–30 mg per day has been reported in dialysis patients. Furthermore, many dialysis patients have some residual renal function, accounting for some renal drug removal. The postdialysis dose will replace drug lost during hemodialysis and drug removed due to nonrenal and residual renal excretion; thus, the amount of postdialysis dose may vary considerably and should be adjusted on the basis of the plasma drug levels achieved (see below).

b. **Peritoneal dialysis patients.** The easiest strategy for treating nonperitoneal infections in continuous ambulatory peritoneal dialysis (CAPD) and automated peritoneal dialysis (APD) patients is to give the usual loading dose IV and then to add 4–6 mg/L to the peritoneal dialysis solution. Although the

strategy is simple, its efficacy and safety have not been evaluated, and there is a concern for otovestibular toxicity if treatment is prolonged. An alternative strategy for patients receiving CAPD or APD would be to give the usual loading dose followed by parenteral (IV or IM) or intraperitoneal (IP) administration of additional small doses based on serum drug levels.

- c. **CRRT.** CRRT effectively removes aminoglycosides. The half-life of aminoglycosides in patients on CRRT is around 18–60 hours. In CRRT, a loading dose of 2–3 mg/kg should be followed by: 1 mg/kg every 24–36 hours (redose when concentration <1 mg/L) for mild UTI or synergy, 1–1.5 mg/kg every 24–36 hours (redose when concentration <1.5–2 mg/L) for moderate-to-severe UTI, or 1.5–2.5 mg/kg every 24–48 hours (redose when concentration <3–5 mg/L) for systemic gram-negative infection. As with any aminoglycoside dosing, serum drug levels should be obtained to ensure therapeutic levels and avoidance of toxicity.

G. **Amikacin.** The strategy for amikacin is similar to that for dosing gentamicin or tobramycin; however, the loading dose should be 5.0–7.5 mg/kg. Redosing is recommended when prehemodialysis concentration is <10 mg/L or when posthemodialysis concentration is <6–8 mg/L (Heintz, 2009). In peritoneal dialysis patients, the recommended amount of amikacin to add to the peritoneal dialysis solution was formerly 18–25 mg/L. Now there has been a trend to use lower doses of amikacin (e.g., for peritonitis; see Chapter 27). The recommended CRRT dose for amikacin is a 10-mg/kg load with a maintenance dose of 7.5 mg/kg every 24–48 hours, with further adjustment based on serum drug levels. For severe gram-negative rod infections, the target peak concentration is 15–30 mg/L, and redosing is recommended when the concentration is <10 mg/L (Heintz, 2009).

H. **Streptomycin.** One-half of the normal (nonuremic) dosage should be administered after hemodialysis. In CAPD patients, 20 mg/L should be added to the dialysis solution. In CRRT, administer doses every 24–72 hours and monitor levels.

I. **Monitoring of serum aminoglycoside levels.** Serum drug levels should be monitored in all dialysis patients receiving aminoglycosides, except perhaps those being treated with IP aminoglycosides for peritonitis. Monitoring of serum aminoglycoside levels is especially important in cases of serious infection where maximal efficacy is of paramount importance and during prolonged use where otovestibular toxicity is common.

1. **Peak aminoglycoside levels.** The volume of distribution for aminoglycosides in dialysis patients is similar to that for nonuremic patients; therefore, peak serum levels should be similar to those in nonuremic patients given a similar dosage with a similar trough (predose) serum concentration. Ideally, peak levels should be drawn 30 minutes after the end of dose infusion.

2. **Trough aminoglycoside levels.** In nonuremic patients, the dosing interval of the aminoglycosides is adjusted based on the trough (predose) level, as trough levels >2 mg/L (gentamicin, tobramycin) or 10 mg/L (amikacin) are associated with toxicity. In dialysis patients, the altered pharmacokinetics of aminoglycosides may lead to difficulties in dosing. For example, when gentamicin is given posthemodialysis, the magnitude of a subsequent

predialysis level will depend on the frequency of dialysis, as well as on the amount administered and the gentamicin half-life. With daily or even every-other-day dialysis, therapeutic peak levels of approximately 4.0–6.0 mg/L may be associated with predialysis levels of >2.0 mg/L. Thus, predialysis levels >2.0 mg/L may need to be accepted if therapeutic peak levels are desired. Whether predialysis levels of >2.0 mg/L in a dialysis setting predispose patients to otovestibulotoxicity is unknown. This may be an important consideration with prolonged (>7–10 days) therapy.

Prolonged aminoglycoside therapy in peritoneal dialysis patients using IP maintenance dosages will result in random serum aminoglycoside levels of >2 mg/L (for gentamicin or tobramycin) or >8 mg/L for amikacin. For example, the addition of 6 mg/L of gentamicin into the dialysate may result in a steady-state serum level of 3–6 mg/L, which may result in otovestibulotoxicity. Recommendations include administering IP aminoglycosides once daily only or decreasing the concentration of IP aminoglycoside when prolonged therapy is indicated.

3. **When the MIC is known.** When the organism is known and the aminoglycoside MIC has been determined, the strategy should be to achieve a peak serum drug level at least four times greater than the MIC value. Of course, one cannot exceed maximum safe peak drug levels; however, in some instances, the MIC may be quite low, allowing a reduction in aminoglycoside dosage and serum drug levels without compromising treatment efficacy.
- J. **Macrolides and ketolides.** Erythromycin undergoes 5%–20% renal excretion in nonuremic patients and requires no dosage adjustment in the presence of renal insufficiency. The use of erythromycin has been largely supplanted by azithromycin and clarithromycin, which have a more favorable side-effect profile and fewer drug–drug interactions. Clarithromycin doses should be reduced by 50% in those patients with CrCl <30mL/min and given after dialysis. Additional dose adjustments are necessary if coadministered with the protease inhibitors atazanvir and ritonavir, which may increase the serum concentration of clarithromycin. As with erythromycin, azithromycin does not require dosage adjustment for intermittent hemodialysis, peritoneal dialysis, or CRRT (Heintz, 2009).

The ketolides are a new class of antibiotics, similar to the macrolides. To date, telithromycin is the first and only agent on the market in the United States. Compared with the macrolides, the ketolides have additional activity against multiresistant *Streptococcus pneumoniae*, *S. aureus* (methicillin- and erythromycin-susceptible isolates only), *Haemophilus influenzae*, *Moraxella catarrhalis*, *Chlamydia pneumoniae*, and *Mycoplasma pneumoniae*. Telithromycin is currently approved only for mild to moderate community-acquired pneumonia; safety issues regarding hepatotoxicity and fatal cases of myasthenia gravis alerted the Food and Drug Administration (FDA) and led them to remove prior approved indications for acute bacterial sinusitis and acute bacterial exacerbations of chronic bronchitis. In hemodialysis, the recommended dose is 600 mg once daily, and when renal impairment is accompanied by hepatic impairment, the dose should be further reduced to 400 mg once daily.

K. **Glycopeptides.** Vancomycin is useful for the treatment of severe gram-positive infections in dialysis patients. As vancomycin is excreted by the kidneys, dosing intervals can be substantially increased in patients with renal failure. In the past, doses could be administered every 7–10 days in patients with no renal excretory function since drug removal is negligible when low-flux dialyzers are employed. However, now that high-flux membranes are used routinely, substantial extracorporeal removal of vancomycin during dialysis can be expected and postdialysis supplements are needed.

Measurement of serum drug levels is necessary to ensure adequate bactericidal levels and to avoid ototoxicity. In the past, target peak and trough plasma concentrations were typically 30–40 and 5–10 mg/L, respectively, and a usual regimen was to give a 1-g loading dose followed by 500 mg after each hemodialysis session. However, these doses are frequently inadequate, especially in patients with high body mass index. Moreover, the development of antibiotic resistance resulting in the need for higher vancomycin trough levels (15–20 mg/L) has been noted (Vandecasteele and De Vriese, 2010). It is now recommended that hospitalized patients with life-threatening infection should receive a 25–30 mg/kg (max 2 g) loading dose followed by posthemodialysis supplements guided by trough levels. Posthemodialysis doses of 500–1,000 mg or 5–10 mg/kg are recommended when trough levels are <10–15 mg/L (Heintz, 2009). An alternate strategy of redosing based on prehemodialysis concentrations is as follows: if <10 mg/L, administer 1,000 mg after hemodialysis; if 10–25 mg/L, administer 500–750 mg after hemodialysis; and if >25 mg/L, hold vancomycin.

Vancomycin is removed to only a minimal extent by peritoneal dialysis, and dosing is similar to that for hemodialysis patients. Vancomycin administration via peritoneal dialysis fluid should be 15–30 mg/L of peritoneal dialysis fluid, and systemic administration for peritoneal dialysis patients is with a loading dose of 1,000 mg, followed by 500–1000 mg every 48–72 hours with close monitoring of levels. In less ill patients who are managed in the outpatient hemodialysis center, once an administered posthemodialysis supplement has been shown to result in a desired trough concentration (i.e., prior to the next hemodialysis session), continued drug monitoring may not be necessary (Pai and Pai, 2004).

Suggested dosing for vancomycin in CRRT is as follows: CH, loading dose of 15–25 mg/kg, followed by either 1,000 mg every 48 hours or 10–15 mg/kg every 24–48 hours; CHD, loading dose of 15–25 mg/kg, followed by either 1,000 mg every 24 hours or 10–15 mg/kg every 24 hours; and CHDF, loading dose of 15–25 mg/kg, followed by either 1,000 mg every 24 hours or 7.5–10 mg/kg every 12 hours. For all forms of CRRT, redosing should be considered for vancomycin concentrations <10–15 mg/L. Vancomycin dosing is based on actual body weight.

In 2009, telavancin, an IV glycopeptide with activity against MRSA became available for the treatment for complicated skin infections. It exhibits concentration-dependent killing and is nearly 90% protein bound. In 2013, it received expanded indications for hospital-acquired and ventilator-associated pneumonia caused by susceptible *Staphylococcus aureus*. Use should be limited to situations when alternative treatments are not suitable, owing to increased mortality in patients with renal insufficiency treated for pneumonia with telavancin compared with vancomycin (Rubinstein, 2011). Black box warnings for

telavancin also include the risk of new onset nephrotoxicity, and potential teratogenicity. Patients with baseline comorbidities or receiving concomitant medications known to affect kidney function are particularly vulnerable to nephrotoxicity. Renal adjustment is necessary in patients with CrCl <50 mL/min; however, no adjustments are provided by the manufacturer for patients with CrCl <10 mL/min or on hemodialysis owing to limited studies.

- L. **Linezolid.** Linezolid is predominantly metabolized by the liver into two inactive metabolites. Although nearly one-third of the dose is excreted unchanged by the kidneys, renal dose adjustment is not required. The two primary metabolites may accumulate in patients with renal impairment, but the clinical significance is unknown. Monitoring for hematopoietic (e.g., anemia, leukopenia, thrombocytopenia) and neuropathic (e.g., peripheral neuropathy) adverse events when administering for extended periods is recommended. If linezolid is not given immediately after a dialysis session, then a supplemental dose, especially early in the treatment course, may be considered. However, no supplemental dose or dosage adjustment for patients on intermittent hemodialysis, peritoneal dialysis, or CRRT has been suggested (Heintz, 2009; Trotman, 2005).
- M. **Daptomycin.** Daptomycin is a large molecule that does not appear to be readily removed by dialysis or CRRT. Higher doses of 6 mg/kg every 24 hours are recommended for *Staphylococcal* bacteremia. In obese patients, doses should be based on adjusted body weight. Dose adjustments in hemodialysis and CRRT used to coincide with the dose recommended for patients with CrCl <30 mL/min (Trotman, 2005); however, for CRRT, this dosing strategy appears to result in a low C_{max} . Thus, patients on CRRT may require 4–6 mg/kg every 24 hours (or 8 mg/kg every 48 hours), depending on site or severity of infection, and whether or not the patient is responding to standard dosing (Heintz, 2009). Alternatively, in intermittent hemodialysis and peritoneal dialysis, daptomycin can be dosed at 6 mg/kg after hemodialysis 3 times weekly (Salama, 2010). Baseline and weekly creatine phosphokinase monitoring should be performed while patients receive daptomycin in view of the risk of myopathy and rhabdomyolysis.
- N. **Tetracyclines.** Use of tetracyclines is generally avoided in patients with renal insufficiency because of the antianabolic effect of these drugs; the use of tetracyclines can lead to an increase in the plasma urea nitrogen level and to worsening acidosis. When a tetracycline is necessary, doxycycline may be used. Although doxycycline also has antianabolic effects, the percentage of renal excretion for doxycycline (normally 40%) is lower than that for tetracycline (60%). Doxycycline is poorly removed by dialysis, and no supplemental dose or dosage adjustment is necessary for patients on intermittent hemodialysis, peritoneal dialysis, or CRRT. Minocycline is minimally excreted by the kidney and can be given in the usual dosages, but should not exceed 200 mg per day.
- O. **Glycylcyclines.** Tigecycline is the first FDA–approved drug from a new class of antibiotics called the glycylcyclines. It is indicated for complicated skin and skin structure infections, complicated intra-abdominal infections, and community-acquired bacterial pneumonia. Owing to a 2010 analysis showing an increased risk of death with tigecycline for approved uses as well as unapproved uses, it should be reserved for situations when alternative treatments are not suitable. Tigecycline is structurally similar to the tetracyclines and is

derived from minocycline. It has gram-positive and gram-negative activity as well as activity against methicillin-resistant *S. aureus*. Tigecycline is cleared by the liver and requires no renal dose adjustments in hemodialysis, peritoneal dialysis, or CRRT.

P. **Diaminopyrimidines.** Trimethoprim may raise serum creatinine values in patients with renal impairment because of interference with tubular secretion of creatinine; this is not accompanied by a reduction in the true glomerular filtration rate (as measured by the clearance of inulin). Trimethoprim is normally 80%–90% excreted by the kidney. Renal excretion of sulfamethoxazole is normally 20%–30%. Trimethoprim and sulfamethoxazole are removed well by hemodialysis but poorly by peritoneal dialysis. For treatment of UTIs, one single-strength tablet containing 80 mg of trimethoprim and 400 mg of sulfamethoxazole should be given twice daily. When giving high-dose IV trimethoprim/sulfamethoxazole (e.g., for treatment of *Pneumocystis carinii* pneumonia) in dialysis patients, 50% of the usual dose (the latter being 15–20 mg/kg per day based on the trimethoprim component) is given as divided doses every 6 to 12 hours; the incidence of leukopenia may be increased when treating dialysis patients, and careful monitoring is essential. In CRRT, doses of 2.5–7.5 mg/kg of trimethoprim every 12 hours are recommended and are highly dependent on indication. Critically ill patients with *Pneumocystis carinii* pneumonia receiving CHDF may require up to 10 mg/kg every 12 hours (Heintz, 2009).

Q. **Antituberculars.** Rifampin is used in the treatment of *S. aureus* skin exit site infections and peritonitis. Rifampin dosage does not need to be adjusted in dialysis patients as the half-life does not differ if dosing is less than 600 mg daily. IP dosing of rifampin for treatment of peritonitis should be considered, given the low dialysate concentration of the by mouth formulation, according to the International Society for Peritoneal Dialysis guidelines. The percentage of renal excretion of isoniazid will vary depending on whether the patient acetylates the drug slowly (renal excretion = 30%) or rapidly (renal excretion = 7%); however, this rate does not seem to alter clinical results. Isoniazid is removed well by dialysis (50%–100%) and should be given postdialysis. Usually, doses are not adjusted in dialysis patients because decreased renal excretion is balanced by removal during dialysis. However, some authors recommend a small dosage reduction (e.g., 200 mg per day rather than 300 mg per day), because accumulation of isoniazid may occur in patients who are “slow acetylators” receiving 300 mg per day.

Ethambutol is largely excreted by the kidney in nonuremic patients. In dialyzed patients, an increase in the dosing interval is required (see Table 35.3). Patients on dialysis should receive the same pyrazinamide dose as patients with a CrCl <30 mL/min.

R. **Antivirals.** The neuraminidase inhibitors zanamivir and oseltamivir are used for prophylaxis and treatment against influenza A and B, whereas the adamantines, amantadine and rimantadine, are no longer recommended for use in the United States for this purpose owing to high resistance rates (Fiore, 2011). Amantadine can also treat parkinsonism and drug-induced extrapyramidal symptoms. Amantadine should be used with great caution in hemodialysis patients as excretion of amantadine is almost exclusively renal. Because of its large volume of distribution, amantadine is removed very slowly by either hemodialysis or peritoneal dialysis. Rimantadine is primarily metabolized by the liver, with <25%

typically excreted unchanged by the kidney and is not removed by hemodialysis.

Oseltamivir requires dose adjustment for CrCl <60 mL/min and requires weight-based dosing in children with renal impairment. It does not appear to cause serious dose-related adverse events (Aoki, 2012). Zanamivir is administered via inhalation; owing to the low likelihood of its systemic absorption, renal dose adjustment is not necessary.

Acyclovir, famciclovir, and valacyclovir all treat herpes simplex and varicella-zoster infections, and require dosage reduction in the presence of renal dysfunction. Failure to appropriately reduce the dose of acyclovir can lead to severe central nervous system toxicity, particularly in CAPD patients (Stathoulopoulou, 1996). In patients with residual renal function, IV acyclovir can lead to the formation of insoluble crystals in the renal tubules, which can lead to acute kidney injury (Perazella, 2003). Risk is decreased with administration of IV acyclovir over 1–2 hours (Laskin, 1983). Valacyclovir is the prodrug to acyclovir and offers about 55% more bioavailability (Perry and Faulds, 1996). Oral famciclovir is a prodrug to penciclovir, and the latter is available only as a topical formulation. Famciclovir provides good bioavailability, which requires adjustment for renal dysfunction, and it has a similar toxicity profile to acyclovir.

Several antiviral agents are currently employed for the treatment of CMV infections and CMV prevention in transplanted patients (cidofovir, foscarnet, ganciclovir, valganciclovir). Cidofovir has an active metabolite with a half-life of 65 hours, thus allowing for weekly dosing. It is contraindicated in patients with a CrCl \leq 55 mL/min (Lea and Bryson, 1996). Its most significant side effect is dose-dependent nephrotoxicity that presents like a Fanconi-type syndrome. The risk can be reduced by giving 1 L of normal saline over 1–2 hours directly before cidofovir administration and giving probenecid 2 g by mouth 3 hours beforehand and 1 g 2 and 8 hours following cidofovir.

Foscarnet is primarily used in CMV-infected patients that have resistance to ganciclovir. It is only available as an IV drug owing to poor bioavailability of the oral formulation. Foscarnet is associated with a >10% incidence of renal insufficiency, likely attributed to direct toxicity to renal tubular cells (Trifillis, 1993). High-flux dialysis for 2.5 hours has demonstrated 38% removal of foscarnet. Induction therapy with foscarnet of 60–90 mg/kg post dialysis followed by maintenance doses of 45–60 mg/kg, aiming at peak plasma concentrations of 400–800 μ mol/L has been suggested. In CRRT, dosing should be the same as for patients with CrCl of 10–50 mL/min. Valganciclovir is a prodrug of ganciclovir with higher oral bioavailability than oral ganciclovir. Owing to ganciclovir's poor bioavailability, the IV formulation is more commonly used. The manufacturer recommends that valganciclovir be avoided in patients receiving hemodialysis and to consider ganciclovir, instead. Patients should be closely observed for bone marrow toxicity while on any of these four antivirals.

- S. **Antiretrovirals.** The nucleoside/nucleotide reverse transcriptase inhibitors (NRTIs) were the first class of antiretrovirals available for clinical use. Zidovudine (azidothymidine or AZT) was the first NRTI to be approved for the treatment of HIV/AIDS. It is predominantly hepatically metabolized to the inactive glucuronide metabolite GZDV with only about 20% excreted unchanged by the kidneys. In renal failure, alteration in elimination and GZDV accumulation necessitate dosage reduction (generally a 50%

reduction) in order to avoid toxicity. Severe granulocytopenia in ESKD patients with 100 mg t.i.d. dosing has been observed. There is no significant removal of the drug or its metabolite by either hemodialysis or peritoneal dialysis. Other NRTIs (e.g., didanosine, emtricitabine, lamivudine, tenofovir, stavudine) also require dosage adjustments in renal failure (see Table 35.3). Abacavir is the only NRTI that does not require dosage adjustment. Tenofovir has been reported to cause nephrotoxicity, which could be important in patients with residual renal function.

With the exception of lopinavir/ritonavir and atazanavir, none of the protease inhibitors—darunavir, fosamprenavir, indinavir, nelfinavir, ritonavir, saquinavir, and tipranavir—require dosage adjustment in patients with renal failure not on hemodialysis. Pharmacokinetic evaluations of most protease inhibitors in hemodialysis patients have not been conducted. Studies have been performed with atazanavir, lopinavir, and ritonavir that exhibit significantly lower concentrations in hemodialysis patients despite being hepatically cleared. Boosted therapy of atazanavir 300 mg with ritonavir 100 mg once daily is recommended in patients on dialysis considered antiretroviral-naïve. However, atazanavir should be avoided altogether in antiretroviral-experienced patients on dialysis because of evidence of moderate increases in atazanavir clearance and decreased exposure levels in patients managed with hemodialysis. Lopinavir/ritonavir should not be given less than twice daily with hemodialysis. Caution should be exercised with patients whose HIV virus has protease inhibitor resistance mutations as lopinavir and ritonavir levels may not be adequate for viral suppression in dialysis patients. Numerous drug–drug interactions with protease inhibitors exist because of their metabolism through the hepatic cytochrome P450 isoenzyme system, and monitoring for these interactions is warranted.

The nonnucleoside reverse transcriptase inhibitors (NNRTIs) nevirapine, delavirdine, efavirenz, and rilpivirine are a heterogeneous group with respect to limited renal clearance (see Table 35.3). Dose adjustments for patients with chronic kidney disease not on dialysis are not provided by the manufacturer for nevirapine, delavirdine, and efavirenz, owing to limited studies. A supplemental dose of 200 mg is recommended for nevirapine following each dialysis session. Rilpivirine exhibits extensive protein binding, which makes significant removal by hemodialysis or peritoneal dialysis unlikely.

Enfuvirtide belongs to a new class of antiretrovirals (i.e., fusion inhibitors). This drug is reserved only for patients who require salvage therapy and are resistant to all classes of antiretrovirals. The use of this antiretroviral is limited by the need for subcutaneous injections and the substantial cost. Dosage adjustment for chronic kidney disease with enfuvirtide does not appear necessary.

Maraviroc is a chemokine coreceptor antagonist that does not require dose adjustment in mild to moderate chronic kidney disease. However, patients concomitantly receiving potent cytochrome P450-3A inhibitors or inducers and with CrCl <30 mL/min should not receive maraviroc. Hemodialysis has minimal effect on clearance; however, if postural hypotension occurs in patients with ESKD the maraviroc dose should be reduced to 150 mg twice daily.

Raltegravir and elvitegravir/cobicistat both work through inhibiting integrase, the viral enzyme used to incorporate viral DNA into the host cell. While raltegravir does not require

dose adjustment for mild, moderate, or severe chronic kidney disease, elvitegravir/cobicistat used in combination with emtricitabine/tenofovir should not be initiated in patients with CrCl <70 mL/min, and should be discontinued in patients with CrCl <50 mL/min.

To reduce the increasing pill burden of antiretroviral regimens, several fixed-dose combinations are currently available: efavirenz/emtricitabine/tenofovir, zidovudine/lamivudine, rilpivirine/emtricitabine/tenofovir, abacavir/lamivudine, zidovudine/lamivudine/abacavir, and emtricitabine/tenofovir. The general rule in hemodialysis is to substitute with the component drugs and adjust the dose of each drug separately.

- T. **Antifungals.** The use of amphotericin B deoxycholate (conventional amphotericin B), the standard for treatment of fungal infections for decades, is limited because of its nephrotoxicity potential. Three lipid-based amphotericin B formulations are FDA approved (Amphotec, Abelcet, and AmBisome) with the intention of less toxicity compared with amphotericin B deoxycholate. Nephrotoxicity may be a consideration with prolonged use of amphotericin B in patients with residual renal function. All formulations of amphotericin are not dialyzed well, and, consequently, doses do not need to be adjusted for any dialysis modality.

The systemic azole antifungals include two groups: the triazoles, which encompass fluconazole, itraconazole, voriconazole, and posaconazole, and the imidazole group, which includes ketoconazole. Imidazoles have largely been supplanted by triazoles on account of improved efficacy and safety profiles, and the FDA has advised against using ketoconazole as first-line therapy for fungal infections. A patient's medication profile should be reviewed carefully before prescribing these agents in light of the multiple drug–drug interactions, particularly through the cytochrome P450 enzyme system.

Posaconazole affords the broadest spectrum of activity and interacts less with other drugs; however, the oral suspension formulation has an erratic bioavailability owing to its dependence on a high-fat meal. It is also available as delayed-release tablets, which provides an option in fasting patients. An IV formulation has recently become available in April 2014, but is not recommended for use in patients with CrCl <50 mL/min. Itraconazole and voriconazole have erratic bioavailability, which is improved somewhat with use of the suspension formulation as opposed to the capsule. Voriconazole can also exhibit decreased bioavailability when taken with high-fat meals, and bioavailability is subject to variability on account of genetic factors, also. Voriconazole is the gold standard for the treatment of invasive aspergillosis. While oral voriconazole is not dose adjusted with renal dysfunction, the IV form cannot be given if a patient's CrCl is <50 mL/min owing to the accumulation of the vehicle cyclodextrin. The Infectious Diseases Society of America Guidelines recommend drug level monitoring for itraconazole when it is being used to treat aspergillosis, histoplasmosis, or blastomycosis. It is also becoming more common to see the monitoring of voriconazole and posaconazole drug levels, with trough recommendations between >1 mg/L and <5.5 mg/L, and ≥ 0.7 mg/L, respectively.

Fluconazole has excellent bioavailability and efficacy against yeast, though it has no activity against molds. The only azole antifungal that requires dosage adjustment in renal

dysfunction is fluconazole; some will decrease the dose by one-half in patients with renal dysfunction, while others will extend the interval to every 48 hours while keeping the dose the same. The latter may be more appropriate owing to fluconazole's dose dependence (e.g., the higher the dose, the higher the serum concentration will be above the MIC of the organism). Fluconazole levels are not usually monitored given its predictable bioavailability (Andes, 2009).

Caspofungin, micafungin, and anidulafungin are antifungal agents belonging to a class of drugs called echinocandins. This class of antifungals works on the fungal cell wall compared with the amphotericin formulations and the azole antifungals, which act on fungal cytoplasmic membranes. Benefits of this drug class include effective treatment of fluconazole-resistant *Candida glabrata* and *krusei*, in addition to having fewer side effects relative to other antifungals. The spectrum of activity of all the echinocandins is comparable, and all have FDA indications for esophageal candidiasis and invasive candidiasis. Moreover, all agents are administered in IV form and do not need to be adjusted for renal dysfunction, although the dose of caspofungin should be reduced in moderate hepatic insufficiency. Unlike the azoles, echinocandins do not interact significantly with the cytochrome P450 enzyme class, resulting in fewer drug interactions, though monitoring of calcineurin inhibitor levels is recommended when being given with caspofungin and micafungin.

- U. **Postdialysis supplements.** Recommended posthemodialysis supplements are listed in Table 35.3. These should be given in addition to the maintenance dosages listed. The posthemodialysis supplements recommended here are geared for a conventional, 4-hour hemodialysis treatment only. With very short dialysis treatments, the amount of drug removed by hemodialysis may not be substantial enough to necessitate a posthemodialysis supplement, but timing of dosing so that a dose is given after dialysis is recommended. In general, peritoneal dialysis patients can be treated with usual hemodialysis patient doses. Drug dosing during CRRT has recently been reviewed elsewhere (Heintz, 2009).

References and Suggested Readings

Agarwal SK. Hemodialysis of patients with HCV infection: isolation has a definite role. *Nephron Clin Pract.* 2011;117:c328–c332.

Allon M. Dialysis-catheter related bacteremia: treatment and prophylaxis. *Am J Kidney Dis.* 2004;44:779–791.

Andes D, et al. Antifungal therapeutic drug monitoring: established and emerging indications. *Antimicrob Agents Chemother.* 2009;53:24.

Aoki FY, et al. AMMI Canada Guidelines, “The use of antiviral drugs for influenza: guidance for practitioners 2012/2013”. *Can J Infect Dis Med Microbiol.* 2012;23:e79–e92.

Ballantine L. Tuberculosis screening in a dialysis program. *Nephrol Nurs J.* 2000;27:489–499; quiz 500–501.

Bloom S, et al. Clinical and economic effects of mupirocin calcium on preventing *Staphylococcus aureus* infection in hemodialysis patients. *Am J Kidney Dis.* 1996;27:687–694.

Bruchfeld A, et al. Pegylated interferon and ribavirin treatment for hepatitis C in haemodialysis patients. *J Viral Hepat.* 2006;13:316–321.

- Chapman SW, et al. Clinical practice guidelines for the management of blastomycosis: 2008 update by the Infectious Diseases Society of America. *Clin Infect Dis*. 2008;46:1801.
- Conly JM, Grieves K, Peters B. A prospective, randomized study comparing transparent and dry gauze dressings for central venous catheters. *J Infect Dis*. 1989;159:310–319.
- Degos F, et al. The tolerance and efficacy of interferon-alpha in haemodialysis patients with HCV infection: a multicentre, prospective study. *Nephrol Dial Transplant*. 2001;16:1017–1023.
- Deray G, et al. Pharmacokinetics of 3'-azido-2'-deoxy-thymidine (AZT) in a patient undergoing hemodialysis. *Therapie*. 1989;44:405.
- Dinits-Pensy M, et al. The use of vaccines in adult patients with renal disease. *Am J Kidney Dis*. 2005;46:997–1011.
- Esforzado N, Campistol JM. Treatment of hepatitis C in dialysis patients. *Contrib Nephrol*. 2012;176:54–65.
- Fabrizi F, et al. Intradermal vs intramuscular vaccine against hepatitis B infection in dialysis patients: a meta-analysis of randomized trials. *J Viral Hepat*. 2011;18:730–737.
- Finelli L, et al. National surveillance of dialysis-associated diseases in the United States, 2002. *Semin Dial*. 2005;18:52–61.
- Fiore AE, et al, Centers for Disease Control and Prevention (CDC). Antiviral agents for the treatment and chemoprophylaxis of influenza—recommendations of the Advisory Committee on Immunization Practices (ACIP). *MMWR Recomm Rep*. 2011;60:1.
- Gentile I, et al. Interferon-free therapies for chronic hepatitis C: toward a hepatitis C virus-free world? *Expert Rev Anti Infect Ther*. 2014;12:763–773.
- Gordon CE, et al. Interferon for hepatitis C virus in hemodialysis—an individual patient meta-analysis of factors associated with sustained virologic response. *Clin J Am Soc Nephrol*. 2009;4:1449–1458.
- Grant J, et al. Interferon-gamma release assays are a better tuberculosis screening test for hemodialysis patients: a study and review of the literature. *Can J Infect Dis Med Microbiol*. 2012;23:114–116.
- Heintz BH, Matzke GR, Dager WE. Antimicrobial dosing concepts and recommendations for critically ill adult patients receiving continuous renal replacement therapy or intermittent hemodialysis. *Pharmacotherapy*. 2009;29:562–577.
- Jaber BL. Bacterial infections in hemodialysis patients: pathogenesis and prevention. *Kidney Int*. 2005;67:2508–2519.
- Kallen AJ, Jernigan JA, Patel PR. Decolonization to prevent infections with *Staphylococcus aureus* in patients undergoing hemodialysis: a review of current evidence. *Semin Dial*. 2011;24:533–539.
- Kubin CJ, et al. Incidence and predictors of acute kidney injury associated with intravenous polymyxin B therapy. *J Infect*. 2012;65:80–87.
- Laskin OL. Clinical pharmacokinetics of acyclovir. *Clin Pharmacokinet*. 1983;8:187.
- Lea AP, Bryson HM. Cidofovir. *Drugs*. 1996;52:225.
- Li J, et al. Pharmacokinetics of colistin methanesulfonate and colistin in a critically ill patient receiving continuous venovenous hemodiafiltration. *Antimicrob Agents Chemother*. 2005;49:4814–4815.
- Li, PK, et al. Peritoneal dialysis-related infections recommendations: 2010 update. *Perit Dial Int*.

2010;30:393–423.

- Lok CE, Mokrzycki MH. Prevention and management of catheter-related infection in hemodialysis patients. *Kidney Int.* 2011;79:587–598.
- Marr KA, et al. Catheter-related bacteremia and outcome of attempted catheter salvage in patients undergoing hemodialysis. *Ann Intern Med.* 1997;127:275–280.
- Masuko K, et al. Infection with hepatitis GB virus C in patients on maintenance hemodialysis. *N Engl J Med.* 1996;334:1485–1490.
- Messing B, et al. Antibiotic-lock technique: a new approach to optimal therapy for catheter-related sepsis in home-parenteral nutrition patients. *J Parenter Enteral Nutr.* 1988;12:185–189.
- Meyers CM, et al. Hepatitis C and renal disease: an update. *Am J Kidney Dis.* 2003;42:631–657.
- Novak JE, Szczech LA. Management of HIV-infected patients with ESRD. *Adv Chronic Kidney Dis.* 2010;17:102–110.
- Pai AB, Pai MP. Vancomycin dosing in high flux hemodialysis: a limited-sampling algorithm. *Am J Health Syst Pharm.* 2004;61:1812–1816.
- Patel PR, et al. Epidemiology, surveillance, and prevention of hepatitis C virus infections in hemodialysis patients. *Am J Kidney Dis.* 2010;56:371–378.
- Perazella MA. Drug-induced renal failure: update on new medications and unique mechanisms of nephrotoxicity. *Am J Med Sci.* 2003;325:349–362.
- Perry CM, Faulds D. Valaciclovir: a review of its antiviral activity, pharmacokinetic properties and therapeutic efficacy in herpesvirus infections. *Drugs.* 1996;52:754.
- Rubinstein E, et al. Telavancin versus vancomycin for hospital-acquired pneumonia due to gram-positive pathogens. *Clin Infect Dis.* 2011;52:31–40.
- Rao CY, et al. Contaminated product water as the source of *Phialemonium curvatum* bloodstream infection among patients undergoing hemodialysis. *Infect Control Hosp Epidemiol.* 2009;30:840–847.
- Salama NN, et al. Single-dose daptomycin pharmacokinetics in chronic haemodialysis patients. *Nephrol Dial Transplant.* 2010;25:1279–1284.
- Segall L, Covic A. Diagnosis of tuberculosis in dialysis patients: current strategies. *Clin J Am Soc Nephrol.* 2010;5:1114–1122.
- Stathoulopoulou F, et al. Clinical pharmacokinetics of oral acyclovir in patients on continuous ambulatory peritoneal dialysis. *Nephron.* 1996;74:337.
- Tokars JJ, et al. National surveillance of hemodialysis associated diseases in the United States, 2000. *Semin Dial.* 2002;15:162–171.
- Tong NKC, et al. Immunogenicity and safety of an adjuvanted hepatitis B vaccine in pre-hemodialysis and hemodialysis patients. *Kidney Int.* 2005;68:2298–2303.
- Trifillis AL, et al. Use of human renal proximal tubule cell cultures for studying foscarnet-induced nephrotoxicity in vitro. *Antimicrob Agents Chemother.* 1993;37:2496.
- Trotman RL, et al. Antibiotic dosing in critically ill adult patients receiving continuous renal replacement therapy. *Clin Infect Dis.* 2005;41:1159–1166.
- Van Geelen JA, et al. Immune response to hepatitis B vaccine in hemodialysis patients. *Nephron.* 1987;45:216.
- Vera EM, et al. Urinalysis in the diagnosis of urinary tract infections in hemodialysis patients. *J Am Soc Nephrol.* 2002;21:639A.

- Vidal L, et al. Systematic comparison of four sources of drug information regarding adjustment of dose for renal function. *Br J Med*. 2005;331:263.
- Vistide prescribing information. Gilead Sciences, Inc., Foster City, CA, USA; 1996.
- Walsh TJ, et al. Treatment of aspergillosis: clinical practice guidelines of the Infectious Diseases Society of America. *Clin Infect Dis*. 2008;46:327.
- Wheat LJ, et al. Clinical practice guidelines for the management of patients with histoplasmosis: 2007 update by the Infectious Diseases Society of America. *Clin Infect Dis*. 2007;45:807.
- Zampieron A, et al. European study on epidemiology and management of hepatitis C virus (HCV) infection in the haemodialysis population. Part 3: prevalence and incidence. *EDTNA ERCA J*. 2006;32:42–44.

In dialysis patients, the mineral bone axis is deranged. In attempts to optimize this, a number of drugs are usually given, including phosphorus binders, active vitamin D derivatives, and calcium-receptor-sensitizers. Dietary restrictions are often required to limit the amount of phosphorus absorbed. To understand how to manage the mineral bone disorder (MBD) of chronic kidney disease (CKD), a basic understanding of its pathophysiology is helpful.

- I. **PATHOPHYSIOLOGY.** Three hormones are involved primarily in maintaining mineral bone homeostasis in early CKD: FGF23, calcitriol (also known as 1,25D or 1,25 dihydroxycholecalciferol), and parathyroid hormone (PTH). These hormones interact with the minerals calcium, phosphorus, and, to a lesser extent, magnesium to ensure adequate mineral absorption from the gut, appropriate mineral excretion by the kidney, and optimal conditions in the bone to permit ongoing mineralization and remodeling.

As kidney function declines, there is a progressive loss of the ability to maintain mineral homeostasis and normal bone turnover. The first problem that arises is the need to maintain excretion of phosphorus being ingested from food. The reduced number of functioning nephrons results in an increased phosphorus load being filtered by each nephron. In an attempt to help increase excretion of this added phosphorus load, the levels of the hormone **FGF23** (fibroblast growth factor 23) are increased. FGF23, produced by osteocytes, affects the function of renal tubular cells by acting on a Klotho-FGF receptor complex. FGF23 stimulates phosphaturia by decreasing the expression and activity of sodium-phosphate cotransporters in the renal tubules. These transporters normally function to reabsorb filtered phosphorus, and downregulating them increases the per nephron excretion of phosphorus, limiting phosphorus overload.

A second hormone involved in mineral bone homeostasis is **calcitriol**. Calcitriol is synthesized by the body in a 3-stage process. The first stage occurs in the skin, which, when exposed to ultraviolet light, converts 7-hydroxycholesterol into cholecalciferol (vitamin D₃). Cholecalciferol is an inactive steroid prohormone; it becomes slightly active after the steroid ring is hydroxylated in the 25-position by the liver. This so-called “25-D” can then be fully activated by a third step: hydroxylation of the steroid ring at the 1-position. This final hydroxylation step can occur in a variety of tissues locally, but the most important site where 1,25-D is synthesized is in the renal tubules, by an enzyme called 1- α hydroxylase. Another name for 1,25-D is calcitriol. Calcitriol has many actions pertaining to mineral balance. It

increases gut calcium and phosphorus absorption, increases calcium reabsorption in the kidney, and suppresses the parathyroid gland from making PTH. Calcitriol also helps mineralize bone.

In early CKD, the levels of calcitriol are reduced. This is thought to occur by two mechanisms: (1) the increased levels of FGF23 induced by the need to increase *per nephron* phosphorus excretion suppress the 1- α hydroxylase enzyme in the renal tubules, blocking conversion of 25-D to 1,25-D, and (2) there is less conversion of 25-D to 1,25D because of reduced functioning renal mass. The decrease in 1,25D in early CKD may be somewhat compensatory, as slowing calcitriol synthesis results in reduced phosphorus absorption from the gut, and this in turn reduces the phosphorus excretion burden on the dwindling number of nephrons. The reduced serum 1,25-D levels also result in reduction of gut calcium absorption, and higher serum phosphorus levels can result in lower serum calcium levels directly. Thus, some degree of mild hypocalcemia is not uncommonly seen in moderate to advanced CKD.

The third hormone involved in mineral balance is parathyroid hormone. This is a peptide hormone composed of 84 amino acids, with the primary binding to its receptor requiring the presence of the first two amino acids on the N-terminal of the molecule. The main stimulus to PTH secretion is hypocalcemia, which acts on calcium-sensing receptors on the parathyroid gland. One of the main functions of this hormone is to maintain the serum calcium level. PTH does this in a number of ways: (1) PTH decreases the reabsorption of phosphorus in the kidney, increasing urinary phosphorus excretion. This lowers serum phosphorus, which tends to raise the serum calcium; (2) PTH stimulates the activity of the 1- α hydroxylase enzyme in the kidney that converts 25-D to 1,25-D; normally, this results in more calcitriol, and more calcium being absorbed via the gut; and (3) PTH increases the rate of bone turnover, freeing up calcium from bone. Note that PTH and FGF23 both act to increase renal phosphorus excretion, but they have the opposite effects on the kidney enzyme that makes 1,25D. In a feedback loop, secretion of PTH is inhibited by 1,25D acting on calcitriol receptors in the parathyroid gland. This feedback loop can be exploited physiologically and pharmacologically using calcitriol and various analogs of calcitriol to suppress PTH secretion. Finally, PTH secretion is stimulated by high serum phosphorus levels.

As the glomerular filtration rate (GFR) declines and as circulating 1,25-D levels decrease, intestinal calcium and phosphorus absorption are reduced, thus helping to maintain mineral homeostasis. The net effect of the changes in FGF23, calcitriol, and PTH during progressive CKD is maintenance of serum calcium and phosphorus within the normal range until stage 4 or 5 CKD. The low 1,25 D level, the low serum calcium level, and the high serum phosphorus level, however, all act to stimulate PTH secretion and contribute to worsening hyperparathyroidism. With onset of stage 5 CKD and initiation of dialysis, this elegant homeostasis system breaks down, leading to very high FGF23 and PTH levels, uniformly low calcitriol levels, hyperphosphatemia, and low or low normal serum calcium.

These hormonal changes have adverse effects on bone physiology, as described below. Hyperphosphatemia, common in dialysis patients, contributes to the development of hyperparathyroidism and bone disease, and may play a pathological role in the development and progression of cardiovascular disease. High serum phosphorus levels may contribute to impaired bone mineralization and enhance vascular and other tissue calcification. High FGF23 levels, induced by hyperphosphatemia and other factors, have been shown to induce left

ventricular hypertrophy in animal models.

II. CONTROL OF HYPERPHOSPHATEMIA. The normal range for serum phosphorus is 2.7 to 4.6 mg/dL (0.9–1.5 mmol/L). In dialysis patients, the KDIGO bone guidelines recommend attempting to maintain predialysis phosphorus in the normal range, based on observational data that better phosphorus control is associated with better outcomes. Also, there are data from animal studies showing that hyperphosphatemia stimulates hyperparathyroidism and promotes vascular calcification. In clinical practice, most physicians and dietitians strive to maintain predialysis phosphorus between 3.0 and 5.5 mg/dL (1.0–1.8 mmol/L).

Hyperphosphatemia occurs in anuric dialysis patients because the amount of phosphorus removed during three dialysis sessions per week is only a fraction of the phosphorus absorbed from the diet. For this reason almost all dialysis patients being dialyzed three times per week and eating a normal diet are required to ingest some form of phosphorus binder along with their food to limit the amount of phosphorus absorbed.

Hypophosphatemia in dialysis patients following a conventional 3-per-week schedule is not the norm and usually is the result of markedly reduced food intake unless there was some error in drawing the blood (e.g., from the dialyzer outlet instead of inlet at the start of dialysis) or unless there was excessive use of binders. Patients with persistent predialysis hypophosphatemia while off binders usually also have low protein intake, and should be counseled to increase dietary protein and phosphorus intake. Use of phosphorus supplements (K Phos Neutral, consisting of 8 mmol (250 mg) phosphorus, 13 mmol sodium, and 1.1 mmol potassium, starting at one tab daily) is indicated if the serum phosphorus remains below 3.0 mg/dL (1.0 mmol/L).

A. Dietary restriction. Restricting phosphorus in the diet to 800 to 1,200 mg per day is the key to controlling serum phosphorus. Inorganic phosphates, added as preservatives and flavor enhancers to processed foods, are absorbed much more readily than phosphorus in natural food (Gutekunst, 2011). Continuing patient education by a knowledgeable dietitian is the best method to establish and maintain proper dietary habits. See Table 36.1 and Appendix B for foods high in phosphorus (Moe, 2011; Gutekunst, 2011). Although the phosphorus content of foods is related to their protein content, phosphorus is more readily absorbed from sources of animal protein than from those of plant protein (Moe, 2011).

B. Removal of phosphorus by dialysis. Hemodialysis typically removes about 800 mg of phosphorus per treatment regardless of predialysis serum levels. High flux dialyzers and dialyzers with larger surface areas, as well as use of hemodiafiltration, can increase phosphorus clearance to a modest degree (Penne, 2010). For hemodialysis, the total weekly time on dialysis is the most important factor affecting phosphorus removal. After the first hour of dialysis, the intradialysis serum phosphorus level tends to stabilize at a low level. This is different than what happens with urea, the levels of which continue to fall as dialysis is prolonged. The maintained intradialysis serum levels of phosphorus cause it to behave somewhat like a middle molecule, where even prolonged dialysis sessions continue to improve phosphorus removal. Dialysis frequency has an additional impact on phosphorus removal because during the initial hour of dialysis, intradialysis serum phosphorus is at a higher level than during the remainder of the treatment. The average patient needs 24–28

hours per week of dialysis to allow a predialysis serum phosphorus level <4.5 mg (1.45 mmol/L) without use of phosphorus binders. Patients undergoing frequent and long nocturnal dialysis with weekly dialysis times greater than 24–28 hours per week typically require addition of phosphorus to the dialysis solution to prevent hypophosphatemia.

Peritoneal dialysis removes approximately 300 mg per day of phosphorus when being treated with a CAPD regimen of four 2 L exchanges per day. This also is far less than the amount of phosphorus absorbed from the diet, and as a result, most peritoneal dialysis patients require the use of binders to control serum phosphorus levels.

TABLE

36.1

Foods Especially High in Phosphorus^a

Dairy products (milk, yogurt, cheese)
Organ and processed meat
Beans/peas
Nuts/seeds
Whole-grain breads, bran, and cereals
Many soft drinks (particularly colas)

^aSee also Appendix B.

- C. **Residual kidney function.** Residual kidney function contributes substantially to phosphorus removal from the body, and patients with urine volumes >500 mL per day typically require substantially lower amounts of phosphorus binders and have lower predialysis serum phosphorus levels than anuric patients (Penne, 2011).
- D. **Phosphorus binders.** Phosphorus binders play an important role in phosphorus control in conjunction with dietary restriction. These agents work by binding phosphorus in the gastrointestinal tract, either by forming an insoluble complex or by binding it into a resin. Despite phosphorus dietary restriction and adequate hemodialysis, approximately 90% of dialysis patients continue to need oral phosphorous binders in an effort to control their phosphorus levels. Other than simply lowering phosphorus, recent observational data have suggested that the use of phosphorus binders may also correlate with longer survival and better nutritional status for patients on maintenance hemodialysis (Lopes, 2012; Cannata-Andia, 2013).

See Table 36.2 for a summary of commonly used phosphorus binding agents. One can think of phosphorus binders in two broad categories, those that contain calcium (calcium carbonate and calcium acetate) and those that do not (sevelamer, lanthanum, magnesium carbonate, sucroferric oxyhydroxide, ferric citrate, and aluminum-containing compounds).

1. **Phosphorus binder equivalent dose:** Using data from various comparative studies, one can roughly establish an equivalent dose for various binders relative to the phosphorus binding capacity of calcium carbonate (Daugirdas, 2011). This so-called phosphorus binding equivalent dose (PBED) allows one to compare dosages in patients taking multiple binders or different binders. In U.S. patients with minimal residual kidney

function being dialyzed according to typical U.S. practices, PBED averages around 6 g per day (Daugirdas, 2012). This means that such patients would need 6 g per day of calcium carbonate to control their serum phosphorus (Table 36.3). The average required PBED is somewhat less, around 4–5 g per day, in smaller patients, those with substantial residual renal function, and is also lower in women versus men, as women tend to eat less phosphorus-rich foods such as meats than men.

2. **Calcium load associated with some phosphorus binders.** Calcium acetate, on a gram-per-gram basis, is about as effective as calcium carbonate as a phosphorus binder, but calcium acetate contains only 25% calcium by weight, whereas calcium carbonate contains 40% calcium by weight. Thus, attempting to manage a relatively large, anuric patient solely with calcium carbonate would require giving that patient 6.0 g of calcium carbonate per day, and $0.4 \times 6.0 = 2.4$ g of elemental calcium per day. This is far in excess of the maximum total calcium ingestion recommended by guidelines issued by Kidney Disease Outcomes Quality Initiative (KDOQI) and Kidney Disease: Improving Global Outcomes (KDIGO). Using calcium acetate would be associated with a somewhat smaller calcium load of $0.25 \times 6.0 = 1.5$ g per day. This value is at the upper limit of daily calcium ingestion from both food and binders recommended by KDOQI. For this reason, many patients being managed with calcium-containing phosphorus binders are treated with additional, noncalcium binders.

TABLE

36.2

Selected Phosphorus Binders

Product	Trade Names	Dose (mg) per Tablet	Elemental Calcium	Maximum Dose per Day	Comments
Calcium carbonate	(Generic, Multiple Names)	Multiple doses	40% elemental calcium	1.5 g of elemental calcium/d	Administered with meals as binder; on empty stomach as supplement
	TUMS	500 mg	200 mg/tab	As above (7 tablets)	
	TUMS EX	750 mg	300 mg/tab	As above (5 tablets)	
	TUMS Ultra	1,000 mg	400 mg/tab	As above (3 tablets)	
	TUMS 500	1,250 mg	500 mg/tab	As above (3 tablets)	
	Os-Cal 500	1,250 mg	500 mg/tab	As above (3 tablets)	
	Os-Cal+D	1,250 mg	500 mg/tab	As above (3 tablets)	
Caltrate	600 mg	240 mg/tab	As above (6 tablets)		
Calcium acetate	PhosLo	667 mg	169 mg of elemental calcium/tab	As above (9 tablets)	More expensive than calcium carbonate. Prescription medication
Magnesium carbonate with calcium carbonate	MagneBind	200: 200 mg MgCO ₃ with 400 mg CaCO ₃	160 mg/tab	Dose limited by serum Mg levels and diarrhea	85 mg of elemental magnesium/tab. Dialysate magnesium concentrations should be adjusted
Magnesium carbonate with calcium carbonate	MagneBind	300: 300 mg MgCO ₃ with 250 mg CaCO ₃	100 mg/tab	Dose limited by serum Mg levels and diarrhea	85 mg of elemental magnesium/tab. Dialysate magnesium concentrations should be adjusted
Magnesium carbonate + calcium acetate	Osvaren	435 mg of MgCO ₃ and 235 mg of Ca acetate	60 mg/tab		Reduction of calcium load; Mg may have anticalcification properties; not available in the US
Lanthanum carbonate	Fosrenal	250-mg and 500-mg tablets	0	1,250 mg t.i.d. Higher doses have not been tested long-term	Significantly more expensive than other products. Must be chewed
Sevelamer carbonate	Renvela	400-mg and 800-mg tablets and powder	0	Has been tested to 14 g/d in normal individuals. Dose may be limited by side effect of GI discomfort	Significantly more expensive than other products
Sucroferric oxyhydroxide (PA21)	Velphoro	500 mg	0	3 g/d	Designed to minimize iron absorption from this iron-containing binder
Ferric citrate (JTT-751)	Not yet assigned	210 mg ferric iron	0	2.5 g/d ferric iron	210 mg elemental iron per tablet as 1 g ferric citrate. Associated with significant increase in serum iron markers

Another strategy is to combine magnesium and calcium compounds to bind phosphorus. In the United States, MagneBind, a mixture of magnesium and calcium

carbonate is sold as a dietary supplement and is sometimes used off-label as a phosphorus binder. In Europe, a magnesium/calcium binder made up of magnesium carbonate and calcium acetate (Osvaren) is approved for use as a phosphorus binder based on successful clinical trials (de Francisco, 2010). As shown in Table 36.3, a 6 g per day PBED of Osvaren would be associated with a daily calcium load of only 0.5 g per day. In addition to limiting the amount of calcium absorbed, magnesium-containing binders have at least two potential beneficial effects: (1) magnesium is an anticalcification factor, and it might retard vascular calcification in dialysis patients, although the evidence for this is limited (Spiegel, 2009); (2) mortality tends to be reduced in dialysis patients with higher serum magnesium levels, although it is not clear that magnesium supplementation beyond achievement of physiological serum levels is beneficial. Magnesium overload is something that one needs to watch for in any dialysis patient ingesting sources of magnesium.

A more effective strategy to eliminate the problem of calcium absorption from phosphorus binders is to use one of the newer binders that contain no calcium. Guideline groups recommend avoiding calcium-containing phosphorus binders in patients prone to vascular calcification, or with evidence of vascular calcification; this is hard to do, as the great majority of dialysis patients, especially patients with diabetes, will have evidence of calcification on abdominal X-ray or on visualization of the heart valves.

3. **Dosing relative to meals.** Phosphorus binders are much more effective when they are ingested with meals, and where the amount of binder given corresponds to the phosphorus load of each meal (Schiller, 1989). Some of the binders require ingestion of multiple pills, while reducing the number of pills by making them larger can make swallowing them more difficult. This has been addressed partially with some binders by making them chewable, or else supplying them as a powder that can be sprinkled over food.

TABLE

36.3

Dosages of Selected Phosphorus Binders Required to Reach a Phosphorus Binder Equivalent Dose (PBED) of 6.0 g per day

Phosphorus Binder	Unit dose size (mg)	Phosphate Binder Equivalent Dose of One Tablet to 1 g Ca Carbonate	Dose of Binder Needed to Reach a PBED of 6 g/d	Approximate Number of Tablets to Reach PBED of 6 g/d	Gram of Calcium in a 6-g PBED dose
Calcium carbonate	750	0.75	6.0	8	2.4
Calcium acetate	667	0.67	6.0	9	1.5
Osvaren (Mg carbonate + Ca acetate)	435/235 ^a	0.75	—	8	0.5
Lanthanum	500 ^b	1.0	3.0	6	0
Sevelamer carbonate	800	0.60	8.0	10	0
Sucroferric Oxyhydroxide (Velphoro)	500	1.6	1.5	3.75	0
Ferric citrate	210	0.64	2.0	9	0

The equivalent dose of PA21 is based on a single randomized controlled trial versus sevelamer (Floege, 2014), and thus the equivalent dose is not as precise as for some of the other binders, where multiple studies were considered.

Ferric citrate numbers were obtained from a single clinical randomized controlled trial vs sevelamer and calcium acetate (Lewis, 2014); Osvaren is not available in the United States.

^a Each tablet contains 435-mg Mg carbonate and 235-mg Ca acetate.

^b Tablets are sold by weight of lanthanum and not of lanthanum carbonate.

III. SELECTED PHOSPHORUS BINDING DRUGS

- A. **Calcium-containing compounds.** These agents are often used in the initial management of hyperphosphatemia based on a profile of effective phosphorus binding and low cost. They

may also be useful when some degree of calcium supplementation is desired. However, dose titration is limited by KDIGO recommendations that elemental calcium ingestion should generally not exceed 1.5 g per day. In addition, dialysis solution calcium concentration should be limited to 2.25 to 2.5 mEq/L (1.12 to 1.25 mM) to avoid positive calcium balance during dialysis. The coadministration of calcium and active vitamin D preparations predisposes up to 50% of patients to hypercalcemia, and this practice warrants close monitoring (Schaefer, 1992).

1. **Calcium Carbonate** (40% elemental calcium by weight) is available in a variety of preparations and dose sizes, including TUMS (200 mg of elemental calcium with the regular tablet formulation), Caltrate (240 mg of elemental calcium/tab), and OsCal 500 (500 mg of elemental calcium/tab). A reasonable starting dose is 1–2 tablets with each meal. However, the use of more than 1.5 g of elemental calcium per day exposes patients to excessive calcium loading and the risk of hypercalcemia, and so it is usually impossible to control phosphorus with calcium carbonate alone without very substantially exceeding the maximum recommended targets for calcium ingestion.

Calcium carbonate is available typically as a swallowed tablet, although TUMS does come in chewable formulations. It should be noted that calcium carbonate dissociates best in an acidic environment, and consequently its solubility can be inhibited by medications such as proton pump inhibitors. This agent has the benefit of easy accessibility and low cost. Common side effects include hypercalcemia, constipation, and nausea.

2. **Calcium acetate** (PhosLo, 25% elemental calcium by weight) is available in 667 mg tablets (169 mg of elemental calcium), and the recommended initial dose is two tablets with each meal. Upward titration may be necessary every 2–3 weeks to establish adequate phosphorus control to a maximum daily dose of 1.5 g of elemental calcium. On a mg calcium carbonate versus mg calcium acetate basis, efficacy of the two drugs as phosphorus binders appears to be similar. However, because calcium acetate is 25% calcium while calcium carbonate is 40% calcium, calcium acetate use is associated with less calcium loading. Still, to achieve a PBED of 6 g per day, use of calcium acetate alone engenders the administration of 1.5 g per day of elemental calcium. Administration is a swallowed tablet, and side effects include hypercalcemia, nausea, and constipation,

B. **Sevelamer carbonate** (Renvela) is a nonaluminum-, noncalcium-based phosphorus binder that traps phosphorus in the bowel through ion exchange and hydrogen binding. The drug is available in 400- and 800-mg tablets, and granule packets, and should be started at 800–1,600 mg three times per day with meals. It can be titrated upward to a maximum of 13g per day to attain necessary phosphorus control, though this may require a significant pill load and financial burden for the patient. It is recommended to give other drugs 1 hour before or 3 hours after sevelamer administration. The absence of calcium makes sevelamer useful for those predisposed to hypercalcemia and those already at the limit of calcium supplementation. Sevelamer may also have pleiotropic, beneficial anti-inflammatory effects in dialysis patients that are not completely mediated by LDL cholesterol reduction (Rastogi, 2013).

The main side effects of sevelamer are nausea, diarrhea, dyspepsia, and constipation. Sevelamer use may lead to hypocalcemia, which should be treated with supplemental calcium.

- C. **Lanthanum Carbonate (Fosrenol)** became available in the United States in 2005. As a trivalent cation, lanthanum binds phosphorus ionically. It is a noncalcium, nonaluminum-based binder. It is available in 250-, 500-, 750-, and 1,000-mg chewable tablets that may also be crushed. A reasonable starting dose is 500 mg three times per day with upward titration as needed, but not to exceed 1,250 mg three times per day. Very little lanthanum is absorbed, and to date there has been no evidence of toxic accumulation or adverse effects on bone metabolism (Hutchison, 2009). Its main side effects are similar to the other phosphorus binders and are related to GI discomfort. The chewable preparation may be convenient for patients with a large swallowed pill load, but difficult for patients with poor dentition. In a large prospective randomized European multicenter comparator trial, the efficacy of lanthanum carbonate was compared with that of calcium carbonate. Phosphorus control was similar in both groups; however, there was a significantly lower incidence of hypercalcemia in the lanthanum carbonate group, which makes it particularly useful in individuals at risk for hypercalcemia (Hutchison, 2005).

Both lanthanum and sevelamer are notably more expensive than other available phosphorus binders. Although the long-term safety of lanthanum carbonate has been called into question, subsequent reports over 1, 3, and 6 years have demonstrated a satisfactory long-term safety profile (Hutchison, 2009).

- D. **Magnesium/calcium binders.** These include Magnebind (magnesium carbonate plus calcium carbonate), which is sometimes given off-label in the United States, and Osvaren (magnesium carbonate plus calcium acetate), which has been approved for use in dialysis patients in Europe. The potential benefits, as well as minor risks, of giving magnesium in this context have been discussed above.
- E. **Sucroferric oxyhydroxide (PA21 or Velphoro).** PA21 is an iron-containing phosphorus binder that contains no calcium or aluminum. PA21 completed Phase 3 clinical trials in hemodialysis patients and was approved for use as a phosphorus binder in the United States in 2013 (Floege, 2014). It comes as a 500-mg chewable tablet; the starting dose is 1.5 g per day (3 tablets per day with meals) with a suggested maximum dose of 3 g per day. In contrast to ferric citrate, which is another iron-based phosphorus binder described below, Velphoro is associated with only minimal oral iron absorption.
- F. **Ferric citrate.** Ferric citrate is an iron-based phosphate binder that contains no calcium or aluminum. Ferric citrate has been approved for both CKD and ESKD patients in Japan (Yokoyama, 2014a, 2014b) and was approved in the United States in 2014 based on the results of a Phase 3 52-week clinical trial (Lewis, 2014). Ferric citrate comes as a tablet containing 210 mg ferric iron as 1 g ferric citrate and can be titrated to its maximum dose of 12 tablets/day (2.5 g ferric iron/day). Patients treated with ferric citrate demonstrated significant improvement in serum iron measures (TSAT, ferritin) in addition to a reduced need for IV iron (~50% less IV iron requirement than in control patients treated with non-iron phosphorus binders) and reduced need for erythropoiesis stimulating agents (~24% less than control patients treated with non-iron phosphorus binders) while still maintaining

hemoglobin. The tablet size and relative phosphorus binding ability are shown in Tables 36-2 and 36-3. Ferric citrate may prove highly effective as dual therapy in hyperphosphatemic patients that require iron repletion. However, in patients where iron loading is a concern, ferric citrate may not be an optimal choice.

- G. **Aluminum carbonate and aluminum hydroxide.** Aluminum-based binders were the primary therapy for hyperphosphatemia until the mid-1980's, when the accumulation of aluminum to toxic levels was found to result in hematologic, neurologic, and bone complications. Consequently, these agents should no longer be used chronically. Usage of aluminum-based therapies for short periods may be necessary to reduce severely elevated phosphorus and calcium \times phosphorus products in patients with severe hyperparathyroidism and/or concurrent hypercalcemia. They are also still an important tool for hyperphosphatemia control in developing countries (Mudge, 2011). Co-ingestion of citrate (Shohl's solution, calcium citrate, fruit juices, Alka-Selzer) greatly enhances aluminum absorption and can lead to acute aluminum neurotoxicity.
- H. **Use of more than one phosphorus binder.** Combined treatment with different types of phosphorus binders may be advantageous and cost effective. Regimens should be individually tailored to each patient. Combinations should take into account the patient's medication preferences, side effect tolerance, and financial considerations. Total daily exposure to elemental calcium and magnesium should also factor into the choice of agents used. The combination of calcium- and non-calcium-based agents may provide target phosphorus control and calcium supplementation without risking excess exposure to calcium.

IV. **OPTIMIZING SERUM CALCIUM.** The normal range for serum calcium is 8.4 to 10.2 mg/dL (2.10–2.55 mmol/L), and the KDIGO guidelines recommend maintaining predialysis total calcium within this range. There is great patient variability in the calcium set point (the calcium level at which PTH secretion is 50% of maximum).

Serum calcium circulates in a free (ionized) and a protein-bound state. Total calcium reported on standard lab tests reflects both of these circulating forms. Protein-bound calcium is proportional to the concentration of albumin, which accounts for most of the protein binding. On average, total calcium falls by 0.8 mg/dL for every 1.0 g/dL (0.20 mmol/L for every 1.0 g/L) decrease in albumin. Consequently, in hypoalbuminemia, the total calcium reported from the laboratory can be corrected by using the equation:

$$\text{Corrected calcium (in mg/dL)} = \text{total calcium} + (0.8 \times (4.0 - \text{albumin [in g/dL]}))$$

$$\text{Corrected calcium (in mmol/L)} = \text{total calcium} + (0.20 \times (40 - \text{albumin [in g/L]}))$$

In most new dialysis patients, corrected and ionized calcium concentrations are usually slightly low or in the low normal range. Calculation of corrected calcium can be used to estimate whether a hypoalbuminemic patient's serum calcium is high, normal, or low. Unfortunately, corrected calcium is dependent on which albumin assay is employed, and has been shown to be no more accurate than total calcium in predicting whether ionized calcium is high, normal, or low (Gauci, 2008). Therefore, in dialysis practice, use

of total calcium is recommended, and determination of ionized calcium is indicated when the result could change management. Differing from the older KDOQI bone guidelines, KDIGO does not recommend the routine use of albumin-corrected calcium.

- A. **Hypercalcemia.** Hypercalcemia is usually due to excessive use of calcium-based binders and/or to use of vitamin D receptor agonists that increase gut calcium absorption. Patients with low PTH appear to have the highest range of serum calcium, which may reflect adynamic bone disease (see below) and poor ability of bone to buffer calcium. Advanced hyperparathyroidism associated with a large mass of autonomous parathyroid tissue can rarely result in hypercalcemia in the absence of oral calcium administration or the use of active vitamin D. This is referred to as tertiary hyperparathyroidism.
- B. **Hypocalcemia.** Low levels of total uncorrected calcium are often due to a low serum albumin. A low corrected calcium may be due to poor gastrointestinal absorption of calcium due to vitamin D deficiency, severe hyperphosphatemia, or use of the calcimimetic agent, cinacalcet.
- C. **Dialysis solution calcium concentration.** Dialysis solution calcium should generally be 2.5 mEq/L (1.25 mM) in most patients on chronic hemodialysis. This will usually maintain a neutral calcium balance. Cautious use of a 2.25 mEq/L (1.12 mM) calcium bath or lower can be used to control chronically high serum calcium or to stimulate PTH secretion in patients with chronically low PTH. Use of these lower calcium baths can exacerbate hyperparathyroidism, however, and lead to bone demineralization. Use of very low calcium dialysis solutions also has been linked to an increased risk of QTc dispersion and sudden death (see Chapter 11).

Peritoneal dialysis fluid calcium concentration should be 2.5 mEq/L (1.25 mM) in most patients. A 3.5 mEq/L (1.75 mM) dialysate is available, but should be reserved for patients with a chronically low calcium that the clinician has determined warrants therapy. Higher dialysate calcium concentration, especially when used in conjunction with calcium-based phosphorus binders, creates a chronically positive calcium balance, suppresses PTH, and may contribute to vascular and tissue calcification.

- V. **OPTIMIZING SERUM LEVELS OF 25-D (25-HYDROXYCHOLECALCIFEROL).** 25-D (25-hydroxycholecalciferol) is synthesized by the liver from cholecalciferol and reflects vitamin stores. These are frequently low in dialysis patients. Several factors likely account for the high incidence of deficiency, including poor sun exposure in ill patients, restriction of vitamin D–fortified dairy products for purposes of phosphorus control, and the high prevalence of Black patients who are frequently lactose intolerant and whose dark pigmentation reduces effective vitamin D formation upon ultraviolet light exposure. However, Black patients also appear to have lower D-binding protein levels in the blood, leading to a higher ratio of bioactive (free) hormone to bound hormone. Therefore, Blacks may not have the frequency and severity of vitamin D deficiency that standard testing suggests.

Treatment of vitamin D deficiency is appropriate despite the loss of adequate 1-alpha-hydroxylase activity in the kidney, as other tissues possess this enzyme and produce calcitriol for autocrine and paracrine actions. Treatment has also been shown to increase endogenous calcitriol levels, though not usually to normal (Jen, 2010). Treatment should replete, then

maintain adequate stores. Vitamin D stores are assessed by measuring 25-OH vitamin D in the blood. Levels >30 ng/mL (>75 nmol/L) are considered normal, while levels <30 ng/mL (<75 nmol/L) warrant treatment with ergocalciferol or cholecalciferol.

Treatment of low serum 25-D levels differs between the United States and other countries. The most logical treatment is to give the natural precursor to 25-D, which is cholecalciferol, a compound derived from animal sources. Cholecalciferol is widely available in the United States as a food supplement, but not as an FDA-approved pharmaceutical that is reimbursable. While there is no recommended daily intake for cholecalciferol to maintain stores, 800 to 2,000 IU per day is likely sufficient and safe. In the United States, ergocalciferol is available as a prescription drug. Ergocalciferol, a plant-based sterol, differs from cholecalciferol slightly in terms of structure, but it is hydroxylated by the liver at the 25 position and then dihydroxylated at the 1- α position to yield a biologically active compound similar in action to calcitriol. Ergocalciferol is commonly called vitamin D₂, while cholecalciferol is called vitamin D₃. Most (but not all) assays of serum 25-D levels detect both the 25-D₂ and 25-D₃ compounds. Ergocalciferol can be given as large weekly or monthly doses, or smaller daily doses, and the dose administered should be proportional to the severity of the deficiency, and the size and adiposity of the patient. We commonly prescribe 50,000 IU/ month for 6 months when levels are 15–29 ng/mL (37–72 nmol/L), and 50,000 IU weekly for 2 to 3 months, then 50,000 IU monthly when levels are <15 ng/mL (<37 nmol/L). Obese patients will generally require larger doses or longer repletion due to the fat soluble nature of the vitamin.

VI. **BONE DISEASE IN CKD.** Bone normally undergoes a coordinated turnover, with osteoblast cells producing new bone matrix proteins (osteoid) that undergo mineralization, coupled with the activity of osteoclasts that causes bone resorption. The pathological classification of renal osteodystrophy is based on both the static and the dynamic histological parameters obtained by transiliac bone biopsy. Evaluation of the biopsy for **T**urnover rate, **M**ineralization, and **V**olume, the so-called TMV system, has been proposed as the best method for classifying renal bone disease. Fluorescent labels, tetracycline and demeclocycline, are deposited along the lines of mineralization. Administration of such labels for one to three days followed two to three weeks later by the repeat administration of label allows for the determination of the rate of bone formation. With high bone turnover, for example, the distance between the two labels would be increased. Mineralization is evaluated by examining the osteoid volume, increased osteoid maturation time, or increased mineralization lag time. Bone volume is prone to greatest error because with bone biopsy only a single location is sampled. Any aluminum deposition is tested for by staining the biopsy sample with acid solochrome azurine.

A. **Osteitis fibrosa.** This form of renal osteodystrophy occurs when PTH is persistently high. It is characterized by accelerated formation and resorption of bone due to an increased number and activity of osteoblasts and osteoclasts, and increased marrow fibrosis. The severity of osteitis fibrosa is roughly proportional to the degree and duration of PTH elevation. Mild osteitis fibrosa is probably preferable to adynamic bone (see below) in that bone strength is greater and there is less alteration in mineral metabolism. When osteitis fibrosa is severe, bone is laid down so rapidly that it is not properly mineralized or structured. In such cases, the amount of unmineralized bone (osteoid) is increased. The alignment of the

collagen is irregular instead of in the usual lamellar pattern. This “woven” bone may become mineralized as amorphous calcium phosphorus rather than hydroxyapatite. The resulting bone is more prone to fracture.

The most prominent symptoms of severe osteitis fibrosa are bone and joint discomfort. Metastatic calcification with periarticular calcium deposits may lead to acute joint inflammation or pain and stiffness.

Radiological findings are usually absent in mild disease but are always present in severe hyperparathyroidism. As such, bone films are not generally recommended for the assessment of bone disease in dialysis patients. Hand films most reliably demonstrate changes of hyperparathyroidism. The characteristic finding is bone loss (resorption) in the subperiosteal area, best seen on the radial side of the second and third phalanges. Associated erosion of the tuft of the distal phalanx also may be visible and, when severe, may lead to blunting of the fingertip. The latter changes are pathognomonic of present or past osteitis fibrosa. Evidence of bone resorption also may be seen elsewhere in the skeleton, including the skull, giving it a “salt-and-pepper” appearance, and in the long bones, particularly the lesser trochanter of the femur.

Disorganized, accelerated bone formation is associated with osteitis fibrosa and may be visible radiologically as osteosclerosis. Bone scanning using technetium radiopharmaceuticals will show increased skeletal uptake of isotope. The bone/soft tissue ratio of isotope uptake will be increased; however, bone scans generally add little to the diagnostic evaluation of osteitis fibrosa.

- B. **Adynamic bone.** Adynamic bone disease is characterized by reduced osteoblast and osteoclast number and low or absent bone formation rate as measured by tetracycline labeling. The osteoid thickness is normal or reduced, distinguishing it from osteomalacia. Associated laboratory findings may include an iPTH less than 100 pg/mL (11 pmol/L), low serum bone-specific alkaline phosphatase, and, occasionally, a slightly elevated serum ionized calcium level. Vertebral and peripheral bone densities tend to be normal or low.

The causes of adynamic bone histology are unknown, but persistently low (for dialysis patients) PTH levels play a major etiologic role. Predisposed are the elderly, women, those with diabetes, and subjects of the Caucasian race. Adynamic bone is more common in peritoneal dialysis patients, as is a low PTH. Use of dialysis solution calcium concentration of 2.5 mEq/L (1.25 mM) may reduce the prevalence of adynamic bone and PTH oversuppression. Aluminum is now a rare cause of adynamic bone disease.

Initially thought to be asymptomatic and not requiring treatment, adynamic bone is now known to be associated with a higher fracture rate than osteitis fibrosa. Adynamic bone is also associated with hypercalcemia (likely due to impaired ability of the bone to buffer serum calcium), and vascular and other soft tissue calcification. Symptoms, such as pain from nontraumatic fractures, are usually absent until the disease is advanced.

- C. **Osteomalacia.** Like adynamic bone disease, osteomalacia represents a state of low bone turnover. It differs, however, because of the presence of large amounts of unmineralized osteoid. In the absence of renal failure, vitamin D deficiency is the most common cause of osteomalacia and should be considered in dialysis patients with low bone mass and frequent fractures. This lesion was first described in patients with aluminum overload,

wherein bone aluminum accumulation prevented bone mineralization and also suppressed PTH secretion. With recognition of its toxicity, aluminum is now rarely used as a long-term phosphorus binder, and properly treated dialysis solution is free of aluminum. Consequently, the incidence of aluminum-induced osteomalacia has decreased substantially. Rarely, osteomalacia has been ascribed to iron overload.

- D. **Mixed Lesions.** Some patients display histologic evidence of both osteitis fibrosa and osteomalacia on bone biopsy. Such patients frequently have high PTH levels and impaired bone formation and mineralization. In the past, this condition was often found in patients with concomitant aluminum poisoning.
- E. **Osteoporosis.** The age of patients at the time of starting dialysis continues to increase. Many have preexisting osteoporosis documented with bone densitometry. Medical interventions used routinely for osteoporosis include bisphosphonates, selective or nonselective estrogens, teriparatide (Forteo) if the PTH is persistently low, and vitamin D. None of these treatments have been tested for efficacy and safety in the hemodialysis population. Caution should be used before prescribing these medications to dialysis patients with osteoporosis.

VII. PARATHYROID HORMONE LEVELS

- A. **PTH assays.** Parathyroid hormone is an 84 amino acid peptide (PTH(1-84)) that activates a signaling cascade via the PTH1 receptor present on a variety of tissues. The N-terminal portion of the peptide is essential for binding and receptor activation, while large portions of the C-terminal are not. Fragments of PTH are rapidly cleared by the kidney and accumulate in renal failure. Most fragments cannot activate the PTH1 receptor owing to loss of portions of the N-terminus; however, these fragments were usually detected by single-antibody radioimmunoassays employed in the 1980s.

The so-called intact PTH (iPTH) assays use two separate antibodies to identify “intact” PTH molecules: these assays include a “capture” antibody that reacts to the midregion of the molecule, and a “detection” antibody that binds near the biologically active N-terminus. Use of such “intact” PTH assays greatly diminishes, but does not eliminate, interference of PTH fragments. Initially, it was thought that such dual antibody assays bound to PTH(1-84) only. However, several incomplete PTH fragments, including the fragment PTH (7-84), are also bound by this assay, and these incomplete fragments account for as much as half of the PTH measured in dialysis patients by the first generation “intact” PTH group of assays.

There are numerous commercial iPTH assays available, and the contribution of inactive PTH fragments to the total PTH measurement varies greatly. Consequently, in dialysis patients, different assays can lead to very different iPTH results (Souberbielle, 2006; Cavalier, 2012), and at higher iPTH values, the discrepancy in results becomes even greater. This large interassay variability means no specific PTH target can apply to all assays, and use of different assays in the same patient (such as a hospital test versus a dialysis center test) can lead to different interpretations.

Some assays employ a detection antibody that binds at or very near the first amino acid, and are referred to as “biPTH”, “bio-intact PTH”, or “whole PTH”. As these assays are thought to bind exclusively to PTH(1-84), measured levels are approximately 55% of the

corresponding iPTH values. In theory such “bio-intact” assays should be superior to the “intact” PTH assays. Clinical practice, however, has not demonstrated that these assays are superior. Most laboratories continue to employ the iPTH assay, and the 2009 KDIGO bone guidelines recommend continued use of the “intact” iPTH assay rather than the theoretically more precise “bio-intact” 1-84 versions.

- B. **PTH target values.** The purpose of treating hyperparathyroidism in dialysis patients is to prevent the development of severe hyperparathyroidism that can cause severe bone disease and fractures, and contribute to tissue calcification. Medical management of hyperparathyroidism is also intended to reduce the need for surgical parathyroidectomy.

The treatment goals should be balanced against the risks of medical interventions. Overtreatment of hyperparathyroidism can induce adynamic bone disease, which predisposes patients to hypercalcemia and vascular calcification.

The 2009 KDIGO bone guidelines recognized the lack of sufficient outcomes trials to make firm recommendations on the management of hyperparathyroidism in dialysis patients. They recommend balancing the potential benefits of treatments against the known and potential risks. In dialysis patients, they recommend maintaining a stable PTH level over time, generally in a range of two to nine times the upper limit of normal (for most assays this is approximately 150 to 600 pg/mL [16–64 pmol/L]), while avoiding hypercalcemia and hypocalcemia. This range is broader than the older KDOQI guideline recommendation of 150–300 pg/mL (16–32 pmol/L; about two to four times the upper limit of normal). The higher target range was recommended because the narrower KDOQI target appeared to lead to oversuppression of bone turnover and hypercalcemia in many patients.

Dialysis patients should not have iPTH maintained below 150 pg/mL (16 pmol/L), as there is a high likelihood of inducing adynamic bone disease. Persistently low PTH values are more likely with overuse of active vitamin D, cinacalcet, and calcium-based phosphorus binders, as well as with use of high calcium dialysis solutions, (e.g., >3.0 mEq/L [1.5 mM]).

Clinicians should remember that in an individual patient, PTH in a given range does not always correlate with the bone disease. Adynamic bone disease has been found in patients with PTH values above the target range, osteitis fibrosa is not uncommon in patients with PTH levels maintained in the target range (although its severity is usually mild), and osteomalacia is due to vitamin D deficiency and has little correlation with PTH. Clinical events (e.g., fractures, hypercalcemia) that do not correlate with the results of repeated PTH measures warrant further evaluation.

- C. **Serum bone and total alkaline phosphatase.** The KDIGO guidelines also suggest monitoring another marker of high bone turnover, such as bone alkaline phosphatase. In clinical practice, this is an expensive test to obtain, and few centers routinely measure it. Normalization of serum alkaline phosphatase, of which bone alkaline phosphatase is a component, may serve as a secondary indicator that the patient does not have high bone turnover, though it is not predictive of whether adynamic bone disease is present.

Serum total alkaline phosphatase is frequently elevated in dialysis patients, usually due to elevation of bone-specific alkaline phosphatase due to osteitis fibrosa from hyperparathyroidism. However, alkaline phosphatase originates from other tissues, the most

important being liver, intestine, and kidney. Bone alkaline phosphatase can be measured when the source of a high serum alkaline phosphatase is in doubt. Alternatively, an elevation of gamma glutamyl transferase (GGT) suggests the increase in alkaline phosphatase may be due to liver disease, and evaluation of the liver and gall bladder is indicated. If GGT is normal, hyperparathyroid bone disease is likely the cause of the elevated alkaline phosphatase, and more intensive treatment may be indicated. In dialysis patients, both total alkaline phosphatase and bone-specific alkaline phosphatase levels are usually elevated in severe hyperparathyroidism and improve during successful treatment. In clinical practice, a PTH value that is two to nine times the upper limit of normal and a normal serum total alkaline phosphatase suggests that hyperparathyroid bone disease is either mild or absent, and therefore intensification of present therapy to suppress PTH may not be indicated.

- D. **Methods of lowering or raising serum PTH.** As discussed in the opening pages of this chapter, the reasons for hyperparathyroidism in CKD are a low level of 1,25-D (1,25-D suppresses the parathyroid gland), low levels of serum calcium (hypocalcemia stimulates the parathyroid gland to produce PTH), and high levels of serum phosphorus (phosphorus stimulates the parathyroid gland). Accordingly, stimulating the vitamin D receptor, raising the serum calcium or activating the parathyroid gland calcium-sensing receptor by other means, or reducing serum phosphorus, could all be expected to lower serum PTH. Raising the serum calcium to the upper limit of the normal range, once popular, is no longer recommended for fear of precipitating or worsening vascular calcification.

If the serum PTH is below the desired level, reducing the dose of PTH-suppressing drugs (such as vitamin D receptor activators or cinacalcet) or lowering the serum calcium slightly (e.g., by lowering dialysis solution calcium or avoiding calcium-containing phosphorus binders) can be expected to increase PTH levels.

- E. **Vitamin D receptor activators.** Active vitamin D (calcitriol) and vitamin D receptor agonists (see Table 36.4) suppress serum PTH in a dose-dependent fashion. The higher the pretreatment PTH, the larger the dose required to suppress PTH into the desired range. The medications are usually given intravenously during each dialysis, but can be given orally, usually two to three times a week. Because these drugs can increase gut absorption of phosphorus, they should be given cautiously to patients with hyperphosphatemia, and preferably only after elevated serum phosphorus levels have been somewhat controlled. A number of observational studies have suggested that use of calcitriol or vitamin D receptor agonist is associated with increased survival (Duranton, 2013), but randomized outcome trials to confirm this observation have not yet been done.
1. **Calcitriol** (Calcijex; Rocaltrol) or $1,25(\text{OH})_2\text{D}_3$ is a synthetic form of the natural compound, and is usually started at 1–2 mcg IV with each hemodialysis or orally two to three times per week in patients treated with peritoneal dialysis. This drug is usually the least expensive formulation of the active vitamin D compounds.
 2. **Paricalcitol** (Zemplar) or 19-Nor- $1,25(\text{OH})_2\text{D}_2$ is a vitamin D analog that has less hypercalcemic and hyperphosphatemic actions in animal studies. In humans, the evidence of superiority over calcitriol is more limited. A large historical cohort study did find improved survival in dialysis patients receiving paricalcitol compared with

calcitriol (Teng, 2003). The initial dose in mcg per dialysis treatment can be estimated by dividing the pretreatment iPTH by 120. An oral formulation of paricalcitol is also available for patients with CKD or patients on peritoneal dialysis. A starting dose of 1 mcg daily or 2 mcg three times a week can be administered to patients with an iPTH less than or equal to 500 pg/mL (53 pmol/L). An initial dose of 2 mcg daily or 4 mcg three times a week can be started in patients with iPTH greater than 500 pg/mL (53 pmol/L).

3. **Doxercalciferol** (Hectorol) or $1\alpha(\text{OH})\text{D}_2$ is a vitamin D prohormone that is metabolized by the liver to active $1,25(\text{OH})_2\text{D}_2$. Initial dosing is 2.5–5.0 mcg intravenously or orally each dialysis treatment.

Dose adjustments of active vitamin D products for PTH control are based on subsequent PTH determinations, which initially should be performed up to monthly to establish control, then reassessed quarterly. If hypercalcemia (calcium >10.2 mg/dL [2.55 mmol/L]) develops, the dose should be decreased by 30%–50% or held until the hypercalcemia resolves then restarted at a lower dose.

TABLE

36.4

Characteristics of Commonly used Vitamin D Analogs

Medication	Trade Name	Route	Dosing Information	Comments
Calcitriol	Rocaltrol	PO	Starting dose: 0.25 mcg daily or 0.5 mcg three times per week Dose range: 0.25–2 mcg daily Available in 0.25- and 0.5-mcg tablets	Monitor calcium and phosphorus at least monthly
	Calcijex	IV	0.02 mcg/kg (or 1–2 mcg) given three times weekly Titrated by 0.5–1 mcg every 2–4 weeks	
Doxercalciferol	Hectorol	PO	Starting dose: 2.5–5.0 mcg three times per week Titrated by 2.5 mcg q8 wk Available in 2.5 mcg tablets	A vitamin D prohormone that is metabolized in the liver to active 1,25(OH) ₂ vitamin D ₂ . Oral administration in dialysis patients is more hypercalcemic and hyperphosphatemic than IV administration
	Hectorol	IV	Starting dose: 2.5–5.0 mcg three times per week Titrated by 1–2 mcg q8 wk	
Paricalcitol	Zemplar	PO	Dosing: 1–2 mcg daily or 2–4 mcg on a thrice-weekly regimen. Titrated by 1-mcg increments on the daily schedule, or by 2 mcg on the thrice-weekly schedule	Causes minimal alterations in calcium and phosphorus, comparable to placebo
	Zemplar	IV	0.04–0.1 mcg/kg or give dose in mcg equal to biPTH/40 or iPTH/80 three times per week Titrated by 30%–50% at 4-week intervals	The IV preparation can also be administered on a once-weekly regimen based on the cumulative weekly dose

F. **Calcimimetics** bind to the calcium sensing receptor on the parathyroid gland, making it more responsive to the ambient ionized calcium; this results in suppression of PTH, a marked decrease in serum calcium, and a slight decrease in serum phosphorus. Unlike active vitamin D products, calcimimetics result in a decrease in serum calcium and phosphorus. Cinacalcet (Sensipar), the only calcimimetic presently available, is a pill available in 30, 60, and 90 mg. Maximal PTH suppression of 60 to 80% occurs 2 to 4 hours after each dose, and 30 to 50% suppression at 24 hours is observed in about two-thirds of patients. Serum PTH should be measured 12 to 24 hours after a dose. The initial dose of cinacalcet should be 30 mg daily regardless of serum PTH, and should not be initiated if the calcium is <8.4 mg/dL (<2.1 mmol/L). The dose should be increased by 30-mg increments to a maximum of 180 mg per day, based on monthly or quarterly PTH results, provided the corrected calcium is >7.8 mg/dL (1.95 mmol/L). A fall in serum calcium accompanies PTH suppression, and hypocalcemia of <7.5 mg/dL (1.87 mmol/L) occurs in about 5% of patients. Hypocalcemia is rarely symptomatic and can be managed by addition of 500 to

1,000 mg of elemental calcium on an empty stomach, an increase or addition of active vitamin D, or an increase in dialysate calcium to 3.0 or 3.5 mEq/L (1.5 or 1.75 mM). Other major side effects of cinacalcet are nausea and vomiting, which occur in up to 30% of patients, and rash.

A large outcomes trial of cinacalcet versus placebo achieved substantial PTH control (median PTH about 300 vs. 700 pg/mL [32 vs. 74 pmol/L] at 6 months) and lower serum calcium levels (median calcium 9.1 vs. 9.9 mg/dL; 2.27 vs. 2.47 mmol/L), but use of cinacalcet did not reduce cardiovascular events or deaths (EVOLVE Trial Investigators, 2012).

VIII. MISCELLANEOUS THERAPIES

- A. **Bisphosphonates.** While these agents can increase bone density in osteoporosis, they have not been adequately tested or shown to be efficacious in dialysis patients. Bisphosphonates decrease bone resorption by inhibiting osteoclasts. This reduction in bone turnover may be deleterious in dialysis patients, creating a form of adynamic bone disease. Generally, these agents should not be used in dialysis patients.
- B. **Teriparatide.** A synthetic form of PTH(1-34), this polypeptide induces a marked increase in bone density in osteoporotic patients when administered as a daily subcutaneous injection. It has not been tested in dialysis patients, but may be of value in the treatment of adynamic bone disease, as PTH levels usually are low in this disorder. Further studies are needed to define the role of teriparatide in low bone turnover disease, and teriparatide has not been FDA approved in this population.

IX. PARATHYROIDECTOMY. Despite aggressive efforts to control PTH levels, surgical parathyroidectomy (PTX) continues to be necessary in those patients with severe hyperparathyroidism. PTX rates were higher among patients who were younger, female, nondiabetic, receiving peritoneal dialysis, and those with a longer duration of dialysis (Foley, 2005).

- A. **Indications.** Failure of high-dosage intravenous active vitamin D and calcimimetic therapy to improve findings of hyperparathyroidism suggests the presence of large, poorly suppressible glands that require removal.

The indications for parathyroidectomy are listed in Table 36.5. When parathyroidectomy is being contemplated for the treatment of refractory osteitis fibrosa or hypercalcemia, very high PTH levels would be expected, and it is important to document this (e.g., iPTH usually more than 1,000 pg per mL [106 pmol/L]) before contemplating surgery. A lower serum PTH level should be suppressible using calcitriol or an active vitamin D analog. Also, lower serum PTH levels or a normal value for bone-specific alkaline phosphatase should prompt one to question the necessity for parathyroidectomy. Bone biopsy should show marked osteitis fibrosa with many osteoclasts, increased tetracycline labeling, and minimal aluminum staining.

- B. **Relative contraindications.** Recent studies have shown that accumulation of aluminum on the bone mineralizing surface increases markedly after parathyroidectomy and suggest that parathyroidectomy should not be done in patients who are aluminum-loaded. If there is a

history of long-term aluminum exposure, a bone biopsy should be performed prior to parathyroidectomy to exclude significant aluminum accumulation.

- C. **Surgical strategy.** Parathyroid surgery is a complex endeavor and requires the services of a surgeon with experience in this procedure. Aberrantly located glands, and three, five, or even six rather than the usual four glands, may be present. An attempt may be made to localize the glands preoperatively using 10-MHz ultrasonographic scanning or thallium-technetium scanning, but this is usually not necessary.

TABLE

36.5

Indications for Parathyroidectomy

1. Severe progressive symptomatic osteitis fibrosa (skeletal pain and/or fractures) despite adequate medical management, including serum phosphorus control and calcitriol therapy
2. Very high levels of PTH plus any of the following:
 - Persistent hypercalcemia if other causes have been excluded
 - Severe intractable pruritus
 - Persistent severe soft-tissue calcification despite attempts to control the serum phosphorus level
 - Idiopathic disseminated skin necrosis (calciophylaxis)
 - Incapacitating arthritis, peri-arthritis, and spontaneous tendon ruptures

Until recently, the operation of choice had been subtotal parathyroidectomy: total resection of three glands and 75% of the fourth. The alternative approach has been total parathyroidectomy with autotransplantation of some parathyroid tissue into the forearm or, more recently, subcutaneously in the presternal area (Kinnaert, 2000). Both procedures entail some disadvantages, including the risks of permanent hypoparathyroidism and recurrence (or lack of resolution) of bone disease or hypercalcemia. Recurrence and failure to improve are troublesome problems; often, it is uncertain whether the cause is hyperfunction of residual or transplanted parathyroid tissue or the unsuspected presence of an additional gland following surgery.

- D. **Chemical ablation.** Percutaneous injection of ethanol or calcitriol into the parathyroid glands of patients with severe secondary hyperparathyroidism has been used to cause regression of the glands and moderate parathyroid hormone secretion. It is performed using ultrasound or color Doppler flow mapping and may be considered in those who are poor surgical risks and in centers with the appropriate expertise (Kakuta, 1999). The risk of recurrent nerve palsy has been reported to be low.
- E. **Postoperative hypocalcemia.** Within several hours of parathyroidectomy, but especially during the first postoperative days, profound hypocalcemia can develop, the severity of which depends on the degree of osteitis fibrosa, which can be predicted by the extent of preoperative serum alkaline phosphatase elevation and bone histology. In addition to oral calcium supplements (2–4 g per day), large dosages of intravenous calcium (0.5–5.0 g per day) and oral or intravenous calcitriol (2–6 mcg per day) may be required to maintain

serum calcium levels in an acceptable range (Dawborn, 1983). Some advocate starting calcitriol and oral calcium therapy a few days before the procedure even in hypercalcemic patients.

X. **CALCIFIC UREMIC ARTERIOLOPATHY (CUA)**, previously known as “calciphylaxis,” is an unusual disorder seen predominately in dialysis patients. Early signs and symptoms include livedo reticularis and extremely painful red nodules, which progress to ulcerative and necrotic lesions. Risk factors include female gender, obesity, and Caucasian race. Exposure to the uremic milieu may be responsible for altering vascular smooth muscle cells and increasing the expression of factors involved in ectopic mineralization, such as osteopontin and core-binding factor alpha (Moe & Chen, 2003). Further mineralization from elevated calcium and phosphorus levels ultimately results in arteriolar calcification, occlusion, and tissue ischemia. A high index of suspicion is necessary to identify the disease as early as possible. The differential diagnosis includes vasculitis, coumadin-associated skin necrosis, cryoglobulinemia, calcinosis cutis, and panniculitis. Bone scan has been reported to identify calcium deposition in 97% with early plaque-only CUA (Fine & Zacharias, 2002). Skin biopsy shows characteristic arteriolar calcifications in the medial layer.

Once the diagnosis is made, calcium-containing supplements and vitamin D analogs should be discontinued, and non-calcium-based phosphorus-binders should be titrated for aggressive phosphorus control. Parathyroidectomy is recommended for those with CUA and elevated iPTH (>500 pg/mL (53 pmol/L)), though hyperparathyroidism is not required for CUA, and patients may in fact have low to normal iPTH levels (Bleyer, 1998). Coumadin, which inhibits the calcium-regulatory matrix gla-protein, should be discontinued. Sodium thiosulfate, at a dose of 25 g IV three times per week, has been reported to completely resolve the lesions in 26% and improve the process in 47% (Nigwekar, 2013). The mechanism of action is unknown (O’Neill & Hardcastle, 2012). Pamidronate has also been cited in a single case report to effect rapid clinical improvement (Monney, 2004). Wound care is critically important in ulcerative lesions, and surgical debridement and antibiotics may be necessary. Hyperbaric oxygen (Basile, 2002) and low-dose tissue plasminogen activator (Sewell & Pittelkow, 2004) have been reported to promote wound healing in single case studies.

XI. **ALUMINUM TOXICITY.** Aluminum toxicity is rarely seen today because of the development of non-aluminum phosphorus binders and improvement in water purity. Among those still exposed to aluminum-based compounds, greater risk for accumulation occurs in diabetics, the iron-deficient, children, and those with exposure to citrate (which increases aluminum absorption). Aluminum bone disease results in diffuse bone pain or fractures with low iPTH, hypercalcemia, and normal alkaline phosphatase.

Confirmation of aluminum toxicity with the deferoxamine (DFO) test should be done in those with serum aluminum levels between 60 and 200 mcg/L (2,160 and 7,200 nmol/L), those with symptoms of aluminum toxicity, and prior to parathyroidectomy in those with known exposure. The combination of low iPTH and an increase in serum aluminum by 50 mcg/L (1,800 nmol/L) 2 days after a 5-mg/kg DFO administration is predictive of aluminum bone disease. Definitive diagnosis is made with bone biopsy and trabecular staining for aluminum deposition.

In all cases of aluminum toxicity, exposure to aluminum must be identified and stopped. DFO can be administered on a weekly basis at a dose of 5 mg/kg for 2 months. To prevent aluminum-related encephalopathy, those with aluminum levels greater than 200 mcg/L (7,200 nmol/L) should undergo intensive hemodialysis with high-flux membranes. Once levels are less than 200 mcg/L (7,200 nmol/L), DFO treatment can be started. Side effects of DFO include ototoxicity, retinopathy, fatal *Mucor* infections, and precipitation of encephalopathy. For more details see the fourth edition of this Handbook (D’Haese and DeBroe, 2007).

References and Suggested Readings

- Armas LAG, et al. 25-hydroxyvitamin D response to cholecalciferol supplementation in hemodialysis. *Clin J Am Soc Nephrol*. 2012;7:1428–1434.
- Basile C, et al. Hyperbaric oxygen therapy for calcific uremic arteriolopathy: a case series. *J Nephrol*. 2002;16:676–680.
- Bleyer AJ, et al. A case control study of proximal calciphylaxis. *Am J Kidney Dis*. 1998;32:376–383.
- Cannata-Andia JB, et al. Use of phosphate-binding agents is associated with a lower risk of mortality. *Kidney Int*. 2013;84:998–1008.
- Cavalier E, et al. Interpretation of serum PTH concentrations with different kits in dialysis patients according to the KDIGO guidelines: importance of the reference (normal) values. *Nephrol Dial Transplant*. 2012;27:1950–1956.
- Chertow GM, et al. Sevelamer attenuates the progression of coronary and aortic calcification in hemodialysis patients. *Kidney Int*. 2002;62:245–252.
- Cicone JS, et al. Successful treatment of calciphylaxis with intravenous sodium thiosulfate. *Am J Kidney Dis*. 2004;43:1104–1108.
- Clark OH, et al. Localization studies in patients with persistent or recurrent hyperparathyroidism. *Surgery*. 1985;98:1083–1094.
- Coen G, et al. PTH 1-84 and PTH “7-84” in the noninvasive diagnosis of renal bone disease. *Am J Kidney Dis*. 2002;40:348–354.
- Cunningham J, Zehnder D. New Vitamin D analogs and changing therapeutic paradigms. *Kidney Int*. 2011;79:702–707.
- Daugirdas JT, et al; the Frequent Hemodialysis Network Trial Group. The phosphate binder equivalent dose. *Semin Dial*. 2011;24:41–49.
- Daugirdas JT, et al; the FHN Trial Group. Effects of frequent hemodialysis on measures of CKD mineral and bone disorder. *J Am Soc Nephrol*. 2012;23:727–738.
- Dawborn JK, et al. Parathyroidectomy in chronic renal failure. *Nephron*. 1983;33:100–105.
- D’Haese PC, DeBroe ME. Aluminum, lanthanum, and strontium. In: Daugirdas JT, Ing TS, Blake P, eds. *Handbook of Dialysis*, 4th ed. Philadelphia, PA: Wolters Kluwer; 2007:714–726.
- de Francisco ALM, et al. Evaluation of calcium acetate/magnesium carbonate as a phosphate binder compared with sevelamer hydrochloride in haemodialysis patients: a RCT (CALMAG study) assessing efficacy and tolerability. *Nephrol Dial Transplant*. 2010;25:3707–3717.
- Delmez JA, Slatopolsky E. Hyperphosphatemia: its consequences and treatment in patients with chronic renal disease. *Am J Kidney Dis*. 1992;19:303–317.
- D’Haese PC, et al. A Multicenter study on the effects of lanthanum carbonate (Fosrenol) and calcium carbonate on renal bone disease in dialysis patients. *Kidney Int*. 2003;63:S73–S78.

- D'Haese PC, et al. Use of low-dose deferrioxamine test to diagnose and differentiate between patients with aluminum-related bone disease, increased risk for aluminum toxicity, or aluminum overload. *Nephrol Dial Transplant*. 1995;10:1874–1884.
- Duranton F, et al. Vitamin D treatment and mortality in chronic kidney disease: a systematic review and meta-analysis. *Am J Nephrol*. 2013;37:239–248.
- EVOLVE Trial Investigators, et al. Effect of cinacalcet on cardiovascular disease in patients undergoing dialysis. *N Engl J Med*. 2012;367:2482-2494.
- Fine A, Zacharias J. Calciphylaxis is usually non-ulcerating: risk factors, outcome and therapy. *Kidney Int*. 2002;61:2210–2217.
- Floege J. When man turns to stone: extraosseous calcification in uremic patients. *Kidney Int*. 2004;65:2447–2462.
- Floege J, et al. A phase III study of the efficacy and safety of a novel iron-based phosphate binder in dialysis patients. *Kidney Int*. 2014;86:638–647.
- Foley RN, et al. The fall and rise of parathyroidectomy in U.S. hemodialysis patients, 1992 to 2002. *J Am Soc Nephrol*. 2005;16:210–218.
- Gallieni M, et al; Italian Group for the Study of Intravenous Calcitriol. Low-dose intravenous calcitriol treatment of secondary hyperparathyroidism in hemodialysis patients. *Kidney Int*. 1992;42:1191–1198.
- Gauci C, et al. and the NephroTest Study Group. Pitfalls of measuring total blood calcium in patients with CKD. *J Am Soc Nephrol*. 2008;19:1592–1598.
- Goldsmith D, Ritz E, Covic A. Vascular calcification: a stiff challenge for the nephrologists. *Kidney Int*. 2004;66:1315–1333.
- Goodman WG, et al. A calcimimetic agent lowers plasma parathyroid hormone levels in patients with secondary hyperparathyroidism. *Kidney Int*. 2000;58:436–445.
- Gutekunst L. Restricting protein and phosphorus: a dietitian's perspective. In: Daugirdas JT. *Handbook of Chronic Kidney Disease*. Philadelphia, PA; Wolters Kluwer; 2011:127–140.
- Hutchison AJ, et al. Efficacy, tolerability, and safety of lanthanum carbonate in hyperphosphatemia: a 6-month, randomized, comparative trial versus calcium carbonate. *Nephron Clin Pract*. 2005;100:c8–c19.
- Hutchison AJ. Lanthanum carbonate treatment, for up to 6 years, is not associated with adverse effects on the liver in patients with chronic kidney disease stage 5 receiving hemodialysis. *Clin Nephrol*. 2009;71:286–295.
- Jen G, et al. Prevention of secondary hyperparathyroidism in hemodialysis patients: the key role of native vitamin D supplementation. *Hemodial Int*. 2010;14:486–491.
- Kakuta T, et al. Prognosis of parathyroid function after successful percutaneous ethanol injection therapy guided by color Doppler flow mapping in chronic dialysis patients. *Am J Kidney Dis*. 1999;33:1091–1099.
- Kinnaert P, et al. Long-term results of subcutaneous parathyroid grafts in uremic patients. *Arch Surg*. 2000;135:186–190.
- Lewis JB, et al. Ferric citrate controls phosphorus and delivers iron in dialysis patients. *J Am Soc Nephrol*. 2014; in press.
- Lomashvili KA, et al. Phosphate-induced vascular calcification: role of pyrophosphate and osteopontin. *J Am Soc Nephrol*. 2004;15:1392–1401.

- London GM, et al. Arterial calcification and bone histomorphometry in end-stage renal disease. *J Am Soc Nephrol*. 2004;15:1943–1951.
- Lopes AA, et al. Phosphate binder use and mortality among hemodialysis patients in the Dialysis Outcomes and Practice Patterns Study (DOPPS): evaluation of possible confounding by nutritional status. *Am J Kidney Dis*. 2012;60:90–101.
- Lopez-Hilker S, et al. Phosphorus restriction reverses hyperparathyroidism in uremia independent of changes in calcium and calcitriol. *Am J Physiol*. 1990;259:F432–F437.
- Moe SM, Chen NX. Calciphylaxis and vascular calcification: a continuum of extra-skeletal osteogenesis. *Pediatr Nephrol*. 2003;18:969–975.
- Moe SM, et al. Vegetarian compared with meat dietary protein source and phosphorus homeostasis in chronic kidney disease. *Clin J Am Soc Nephrol*. 2011;6:257–264.
- Monney P, et al. Rapid improvement of calciphylaxis after intravenous pamidronate therapy in a patient with chronic renal failure. *Nephrol Dial Transplant*. 2004;19:2130–2132.
- Mudge DW, et al. Does aluminium continue to have a role as a phosphate binder in contemporary practice? *BMC Nephrol*. 2011;12:20.
- Nastou D, et al. Next-generation phosphate binders: focus on iron-based binders. *Drugs*. 2014;74:863–877.
- Navarro JF, et al. Relationship between serum magnesium and parathyroid hormone levels in hemodialysis patients. *Am J Kidney Dis*. 1999;34:43–48.
- Nigwekar SU, et al. Sodium thiosulfate therapy for calcific uremic arteriolopathy. *Clin J Am Soc Nephrol*. 2013;8:1162–1170.
- O'Neill WC, Hardcastle KI. The chemistry of thiosulfate and vascular calcification. *Nephrol Dial Transplant*. 2012;27:521–526.
- Penne EL, et al; for the CONTRAST investigators. Short-term effects of online hemodiafiltration on phosphate control: a result from the randomized Controlled Convective Transport Study. *Am J Kidney Dis*. 2010;55:77–87.
- Penne EL, et al. Role of residual renal function in phosphate control and anemia management in chronic hemodialysis patients. *Clin J Am Soc Nephrol*. 2011;6:281–289.
- Rastogi A. Sevelamer revisited: pleiotropic effects on endothelial and cardiovascular risk factors in chronic kidney disease and end-stage renal disease. *Ther Adv Cardiovasc Dis*. 2013;7:322–342.
- Schaefer K, et al. Reduced risk of hypercalcemia for hemodialysis patients by administering calcitriol at night. *Am J Kidney Dis*. 1992;19:460–464.
- Schiller LR, et al. Effect of the time of administration of calcium acetate on phosphorus binding. *N Engl J Med*. 1989;320:1110–1113.
- Sewell LD, Pittelkow MR. Low-dose tissue plasminogen activator for calciphylaxis. *Arch Dermatol*. 2004;140:1045–1048.
- Souberbielle JC, et al. Inter-method variability in PTH measurement: implication for the care of CKD patients. *Kidney Int*. 2006;70:345–350.
- Spiegel DM, Farmer B. Long-term effects of magnesium carbonate on coronary artery calcification and bone mineral density in hemodialysis patients: a pilot study. *Hemodial Int*. 2009;13:453–459.
- Teng M, et al. Survival of patients undergoing hemodialysis with paricalcitol or calcitriol therapy. *New Engl J Med*. 2003;349:446–456.
- Ubara Y, et al. Histomorphogenic features of bone in patients with primary and secondary

hypoparathyroidism. *Kidney Int.* 2003;63:1809–1816.

Wüthrich RP, et al. Randomized clinical trial of the iron-based phosphate binder PA21 in hemodialysis patients. *Clin J Am Soc Nephrol.* 2013;8:280–289.

Yokoyama K, et al. A randomized trial of JTT-751 versus sevelamer hydrochloride in patients on hemodialysis. *Nephrol Dial Transplant.* 2014a;29:1053–1060.

Yokoyama K, et al. Ferric citrate hydrate for the treatment of hyperphosphatemia in nondialysis-dependent CKD. *Clin J Am Soc Nephrol.* 2014b;9:543-552.

Web References

Uremic bone disease links. <http://www.hdcn.com/crf/bone> and <http://kdigo.org/home/mineral-bone-disorder/>.

Choices in dialysis treatment for infants and children are wide and include the full range of therapies utilized in adult patients. Theoretical considerations of clearance, kinetic modeling, and adequacy of dialysis are equally relevant in pediatric dialysis, although they are less well studied in this population than in adults. There are important technical considerations in performing dialysis on patients whose weights may vary by as much as 50-fold. Furthermore, there are indications for and complications of the dialysis procedure that are unique to children. Finally, chronic care of children receiving dialysis is complex and requires attention to growth and cognitive development, age-appropriate nutritional interventions, consequences of metabolic disturbances, and psychosocial adjustment to achieve the goal of complete rehabilitation.

I. ACUTE DIALYSIS

A. **Indications.** The indications for acute renal replacement therapy in an infant, child, or adolescent are similar to those in adults and include:

1. Oliguric acute renal failure where optimal nutritional and medical support will require fluid and/or electrolyte removal
2. Volume overload with congestive heart failure, pulmonary edema, or severe hypertension not manageable with diuretics or conservative measures; fluid overload greater than 20% of body weight in the setting of critical illness may be an independent indication
3. Hyperkalemia with electrocardiographic abnormalities
4. Metabolic acidosis that cannot be safely corrected with sodium bicarbonate administration because of risk of sodium or volume overload
5. Symptoms of uremic encephalopathy, with particular attention to seizures
6. Uremic pericarditis
7. Tumor lysis syndrome or severe hyperuricemia complicating chemotherapy for malignancy
8. Progressively rising blood urea nitrogen (BUN) level in a situation where imminent recovery is not anticipated and uremic consequences are likely. The BUN level where concern arises will vary with the age of the child; 35–50 mg/dL (12–18 mmol/L) is potentially dangerous in an infant, whereas 150 mg/dL (54 mmol/L) in an adolescent may necessitate initiation of dialysis.

9. Inborn error of metabolism with severe organic acidemia or hyperammonemia
10. Toxic ingestion. Guidelines for extracorporeal therapy for poisoning are found in Chapter 20.

B. Choice of acute dialysis modality

1. **Acute peritoneal dialysis** is often used in infants and young children and has several advantages. It does not require sophisticated equipment or technical expertise. One can avoid the need for vascular access, blood priming, and anticoagulation; hemodynamic instability is uncommon. Continuous peritoneal dialysis (PD) provides efficient clearance in small children. It is frequently used as adjunctive therapy to manage fluid overload in infants after cardiac surgery with cardiopulmonary bypass. However, severe hyperammonemia, hyperphosphatemia, or hyperkalemia often require more rapid correction; in such situations, hemodialysis (sometimes in combination with continuous hemo[di]filtration) may be more appropriate. Furthermore, volume removal by ultrafiltration in PD is often unpredictable and may not be rapid enough in some patients with congestive heart failure or pulmonary edema. Dialysate leakage with risk of peritonitis may limit acute PD.

There are no guidelines as to what constitutes adequate PD in acute renal failure (ARF), and one attempts maximum possible clearance to compensate for catabolic stress, utilizing continuous exchanges. The initial prescription may include hourly exchanges; more frequent exchanges can be performed, although a greater fraction of total time is then spent in filling and draining, rather than in solute exchange. An automated cycler facilitates this process, limiting nursing effort and repeated opening of the catheter. Most cyclers can deliver exchange volumes small enough for infants and young children. When a cycler is unavailable or when fill volumes <150 mL are desirable, a safe alternative is the Dially-Nate set (Utah Medical Products, Gesco), which allows one to connect a bag of dialysate to a closed circuit, including a buretrol device (in-line sterile graduated cylinder) connected to the patient's PD catheter, and a drainage line for effluent dialysate attached to a measurement device. The desired volume fills the buretrol and is then infused into the patient; after a defined dwell, the effluent dialysate is drained and measured, and the process is repeated without opening the system. This allows one to perform closed circuit, low-volume, manual continuous PD in infants and very small children.

Exchange volumes may be targeted at 30–50 mL/kg in infants and up to 1,100 mL/m² in children, but immediately after catheter placement, it is prudent to limit volumes to half or less of this volume to avoid leakage, which predisposes to peritonitis. Hourly exchanges may result in obligate ultrafiltration even when 1.5% dextrose concentration is used, so that parenteral or enteral fluid intake is needed to avoid volume depletion and prolongation of ARF.

2. **Acute hemodialysis** is performed when rapid solute clearance is of paramount importance or PD is contraindicated because of an intra-abdominal process (including recent abdominal surgery, diaphragmatic hernia, omphalocele, or gastroschisis) or respiratory limitation.

Acute hemodialysis in infants and small children requires experience and

technical expertise, as well as size-appropriate dialyzers, blood lines, and vascular catheters. Very small patients may require blood or albumin priming of the hemodialysis circuit. Small patient size allows efficient and rapid solute clearance where appropriate (i.e., ammonia), but must be approached with caution where overly rapid osmolar shifts could precipitate seizures (reportedly more common in children than in adults). Dialyzers are available in a range of sizes for children through older adolescents (Table 37.1); however, the choices in small dialyzers have become fewer, and availability is often limited.

3. **Continuous therapies.** Continuous renal replacement therapy (CRRT) has been utilized in pediatric patients, ranging from preterm infants to older adolescents. The physiologic principles are unchanged from those in adults (see Chapter 15); because of small patient size, clearance can be extremely efficient, replacing a large fraction of endogenous renal function. Prospective registry data on CRRT in infants and children are becoming available and providing insights into practice variation and determinants of outcome (Ashkenazi, 2013). We recognize fluid overload as an independent risk factor for mortality in children with acute kidney injury (AKI) receiving CRRT and adjust ultrafiltration to address that. CRRT has been successfully combined with extracorporeal membrane oxygenation support even in infants and provides better volume management than free-flow systems. Further, continuous therapies permit better phosphorus clearance than intermittent hemodialysis or PD and are thus frequently employed in the tumor lysis syndrome in children with Burkitt lymphoma or acute lymphoblastic leukemia.

Maintaining vascular access with adequate flow in small vessels can be problematic (Table 37.2) and is often the limiting factor. There are older reports of arteriovenous hemofiltration (CAVH), but most centers have found pump-driven venovenous treatments to perform more reliably and to maintain circuit patency longer. As in acute hemodialysis, the entire circuit volume must be considered and a blood or albumin prime used if the circuit volume is >10% of the patient's estimated blood volume. The electrolyte concentrations and pH of the blood prime are far from normal values, and many infants will experience hemodynamic instability at initiation of therapy. Zero balance ultrafiltration has been proposed to bring the electrolyte concentrations in the blood prime close to physiologic values, which might avoid instability at initiation (Hackbarth, 2005). Cooling of the blood circuit is a concern in infants; a blood warmer may be used in-line, although with some models this increases the circuit volume. Hemofilters appropriate for pediatric use are listed in Table 37.3. Ultrafiltration is controlled by volumetric pump or automated weighing to avoid errors in replacement fluid, which, if compounded over days of therapy, could be dramatic in a small, anuric patient.

Dialyzer	Priming Volume (mL)	Surface Area (m ²)	Urea Clearance (Q _B 200 or as Specified)	B ₁₂ Clearance (at Highest Tested Q _B)	K _{DA}	Membrane	Manufacturer
Polyflux 6H	52	0.6	50 Q _B = 5097 Q _B = 100136 Q _B = 150167 Q _B = 200	90	465 Q _B = 200	Polyflux (polyarylethersulfone, polyvinylpyrrolidone, polyamide)	Gambro
CA50, CA70	35, 45	0.5, 0.7	128 (147 Q _B = 300), 153 (175 Q _B = 300)	27, 36	243, 333	Cellulose acetate	Baxter
F3, F4, F5	28, 42, 63	0.4, 0.7, 1.0	125, 155 (183 Q _B = 300), 170 (206 Q _B = 300)	20, 34, 47	231, 364, 472	Polysulfone	Fresenius
Filtrzyer B3-0.8A	49	0.8	163	61	404	PMMA	Toray

PMMA, polymethylmethacrylate.

TABLE
37.2 Catheters for Use in Pediatric Extracorporeal Renal Replacement Therapy

Patient Size	Catheter Size	Access Location
Neonate	UVC—5.0 F	Umbilicus
	UAC—3.5, 5.0 F	Umbilicus
	<i>or</i> 5.0 F single lumen	Femoral vein(s)
	<i>or</i> 6.5, 7.0 F dual lumen	Femoral vein(s)
3–15 kg	6.5, 7.0 F dual lumen	Femoral/subclavian vein
16–30 kg	7.0, 9.0 F dual lumen	Femoral/internal jugular/subclavian
>30 kg	9.0, 11.5 F dual lumen	Femoral/internal jugular/subclavian

UVC, umbilical vein catheter; UAC, umbilical artery catheter; F, French gauge.

Currently available machines, including the Gambro Prismaflex (Gambro Lundia AB, Lund, Sweden), the Braun Diapact (B. Braun Medical, Bethlehem, PA), and the NxStage (NxStage Medical Inc., Lawrence, MA), have been used in children, although the NxStage does not permit blood flow rates in a range appropriate for small patients. Several studies have demonstrated the success of CRRT in critically ill infants and children. Ultrafiltration rates in infants and small children may be as low as 5–30 mL/hr without replacement fluid (slow continuous ultrafiltration, SCUF) or as high as 100–600 mL/hr with replacement fluid (C-HF); larger children can tolerate ultrafiltration and replacement rates near those of adults. Commercially available bicarbonate-based dialysate or replacement solution (PrismaSol, PrismaSATE, [Gambro Lundia AB, Lund, Sweden], Accusol, [Baxter Healthcare, Deerfield, IL], Pureflow (NxStage Medical, Inc., Lawrence, MA), Normocarb (Dialysis Solutions Inc., Whitby, ON), or Hemosol BO [Gambro Lundia AB, Lund, Sweden], is the safest choice; errors in local preparation of solutions in hospital pharmacies are well recognized and are no longer appropriate now that standardized solutions are available. Successful circuit anticoagulation has been reported with both heparin and citrate. Since the citrate infusion rate is scaled to circuit blood flow, which is relatively large in infants and small children, citrate accumulation may occur after prolonged therapy, resulting in “citrate lock” or persistently low ionized calcium levels

despite calcium infusion. The combination of fixed concentration bicarbonate-containing replacement fluid and citrate anticoagulation may result in metabolic alkalosis after several days of therapy. In reported series, infants <5 kg are more often anticoagulated with heparin. Doses for systemic heparin anticoagulation in infants are larger than those reported for adults, and monitoring the system by activated clotting times (ACTs) is recommended. Circuit life is significantly shorter in pediatric patients run without anticoagulation.

TABLE

37.3

Hemofilters and Sets Appropriate for Pediatric Use

Hemofilter	Priming Volume (mL)	Surface Area (m ²)	Ultrafiltration Rate (mL/min, $Q_B = 100$)	Membrane	Manufacturer
Minifilter Plus	15	0.07	1–8	Polysulfone	Baxter
RenafloII HF 400, 700	28, 53	0.3, 0.7	20–35, 35–45	Polysulfone	Minntech
Prismaflex, M60, M100 set	93, 152	0.6, 0.9	38,44	AN69	Gambro
Prismaflex HF20	60	0.2		PAES	Gambro

AN69, acrylonitrile and sodium methallyl sulfonate; PAES, polyarylethersulfone.

II. CHRONIC DIALYSIS

A. **Indications.** Optimal management of chronic kidney disease (CKD) avoids some of the historical indications for initiation of dialysis. Anemia, acidosis, hyperparathyroidism, and growth delay can often be managed medically, so nephrologists must be attuned to subtle indications of uremia, that is, diminished energy (less vigorous play), resumption of napping, anorexia (with absence of expected weight gain), and inattentiveness at school or failure to attain expected developmental milestones, in order to recognize the appropriate time to begin dialysis. There is no consensus as to the specific level of GFR at which dialysis should be started. Symptomatic uremia or metabolic disturbances such as hyperkalemia, hyperphosphatemia, malnutrition, or growth failure that cannot be managed conservatively are agreed upon as indications for initiation of renal replacement therapy. Chronic dialysis is usually an interim measure to allow time to prepare for kidney transplantation.

B. Choice of chronic dialysis modality

1. Chronic PD is often the therapy of choice for pediatric patients. Transperitoneal solute exchange in children appears to be as efficient as in adults. Since peritoneal surface area is correlated with body surface area, small children have a relatively large surface for solute exchange compared with adults, which makes PD an effective

modality. Peritoneal equilibration testing (PET) shows that very young children are more likely to fall in the category of high or high-average transport, although this observation appears to be the result of large surface area for transport rather than a difference in peritoneal membrane characteristics and can be corrected for by testing patients at fill volumes of 1,000–1,100 mL/m². Adolescents and teenagers have PET results more typical of adults. Enhanced glucose absorption will result in relatively rapid attainment of osmotic equilibrium between dialysate and plasma, limiting ultrafiltration on long dwells. Automated forms of PD utilizing short dwells are most commonly used in children to accommodate high average peritoneal transport in young children and to improve treatment adherence in older children.

PD offers additional benefits as a chronic dialysis modality. It is technically simple and avoids the need for chronic vascular access (which is particularly difficult in infants and small children). Blood pressure and volume status may be better controlled with PD than with hemodialysis. Less time is spent in the hospital and in the dialysis unit, with more time spent at school and engaged in other age-appropriate activities. Parents often feel they have greater control over their child's care when they perform PD.

- a. **Limitations to peritoneal dialysis.** Previous abdominal surgery may result in intra-abdominal adhesions that make PD impossible, particularly repair of complex urogenital anomalies, which are often a cause of end-stage kidney disease (ESKD) in children. However, one can rarely predict whether adhesions will limit therapy, and a trial of PD is usually warranted. The presence of a ventriculoperitoneal shunt was once considered a relative contraindication to PD; however, multicenter data show that dialysis can be performed successfully without ascending infection even in the setting of peritonitis (Dolan, 2013). The presence of a ureterostomy, pyelostomy, or loop ileostomy is not an absolute contraindication to performance of PD, although the risk of exit site infection and peritonitis with urinary organisms is increased.
- b. **Transplantation in peritoneal dialysis patients.** PD is continued up to the time of renal transplantation without increased risk of infection. The PD catheter is often removed at the time of living-donor transplantation (assuming immediate graft function), but sometimes it is left in place if a deceased donor transplant is performed. The catheter will then be removed electively once graft function is stable; delay in catheter removal has been associated with posttransplantation peritonitis in the dry abdomen.
- c. **Complications of peritoneal dialysis.** The complications of pediatric PD include those already described in adults (see Chapters 28–29). PD presents particular problems for children and families. Months or years of a demanding regimen may result in “burnout” or caregiver fatigue, which exacerbates underlying family conflicts; nonadherence to therapy becomes common, particularly among adolescents. The presence of a PD catheter may adversely affect body image. Children have a higher rate of peritonitis than adults, which further complicates therapy. Eradication of nasal *Staphylococcus aureus* carriage leads to decreased

exit site infection and peritonitis in adults, but studies in children have shown no benefit. Congenital defects in the diaphragm may result in communication between the pleural and peritoneal spaces. In some cases, a change to automated peritoneal dialysis (APD) with empty periods may permit continuation of PD. Some children become obese from excessive glucose absorption from dialysate; this presents additional problems for body image as well as adversely affecting blood lipid levels and an already increased risk of cardiovascular disease. Chronic hypoalbuminemia develops in some patients, particularly with repeated peritonitis; its long-term consequences for growth in stature and lean body mass are unknown.

C. Apparatus for acute and chronic peritoneal dialysis

1. Lactate-based PD solutions are available in a range of bag sizes appropriate for small patients who perform chronic ambulatory peritoneal dialysis and automated (cycler) PD. Calcium concentrations of 1.25 mM and 1.75 mM are used, depending on the desired calcium balance and type and amount of phosphorus binder being used. Standard dextrose concentrations (1.5%, 2.5%, and 4.25%) are utilized, depending on the need for ultrafiltration. Enhanced glucose absorption in small children occasionally warrants higher glucose concentration to maintain ultrafiltration, although short-dwell dialysis is usually preferred in that situation. Amino acid-containing PD solution is tolerated in children, although there remains a greater reliance on supplemental tube feeding in infants and young children. Icodextrin-containing solutions have been used in children for long dwells to limit peritoneal glucose exposure. Neutral pH solutions of pure bicarbonate or a bicarbonate/lactate combination have been shown to be safe in children and offer the potential benefit of protection of peritoneal membrane integrity. The long-term impact of new solutions on acid–base and nutritional status is still unclear, and their role in chronic care of pediatric PD patients is still to be determined.
2. PD catheters are available in neonatal and pediatric sizes of almost any configuration used in adults, including Tenckhoff (curled and straight), swan-neck, and Toronto-Western, usually with a choice of one or two cuffs. Most commonly placed in children is a curled Tenckhoff catheter with a straight tunnel; North American Pediatric Renal Trials and Collaborative Studies data suggest a benefit to double-cuffed catheters and downward-oriented exit sites in decreasing peritonitis rates.
 - a. **Implantation.** Chronic catheters are almost invariably implanted surgically in pediatric patients under general anesthesia. Laparoscopic placement is preferred if surgical experience is available. Laparoscopic technique allows the surgeon to see that the catheter is placed in an optimal position, and it minimizes incision size and healing time. Several technical points appear to be important:
 1. Sealing the peritoneum around the catheter (to prevent leakage) by use of a pursestring suture, which is also affixed to the cuff. The exit site should be directed caudally, as shown in Figure 37.1, to facilitate drainage and to minimize the risk of exit site infection.
 2. Use of a second pursestring suture to seal the posterior rectus sheath opening and fix the posterior rectus sheath to the upper part of the cuff (to prevent leakage and displacement; this is not shown in Fig. 37.1).

3. Performance of a partial omentectomy (to prevent obstruction)
4. Intraoperative search for and closure of associated hernial defects, especially a patent tunica vaginalis.
5. Intraoperative testing of the catheter to verify that there is free inflow and outflow of dialysate.

We try to allow 2 weeks for healing of the abdomen before using the catheter. It can be used immediately for acute PD or unanticipated clinical deterioration in CKD but one risks early leakage. Small exchange volumes and performance of APD in the supine position may help avoid dialysate leakage.

- b. Acute “temporary” catheters can be placed after prefilling the abdomen with dialysate as in adults (see Chapter 23 for description of the technique in adults). Older acute PD catheters were much stiffer than chronic catheters, conferring a greater risk of bowel injury. Newer, more flexible acute PD catheters have been developed, and some have reported success with their use with a low leakage and infection rate. However, most centers utilize a surgically implanted chronic PD catheter for acute peritoneal dialysis, placing it at bedside in the intensive care unit in the most unstable patients.

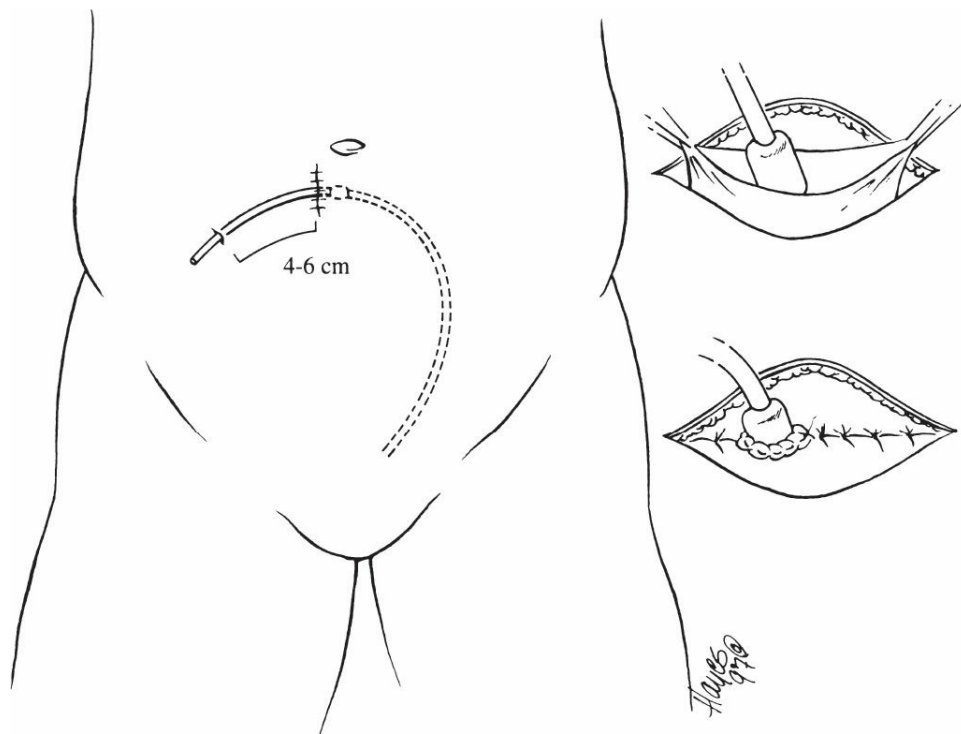

FIGURE 37.1 One method of implanting a peritoneal catheter in children. The pursestring suture used to seal the peritoneum includes the catheter cuff. A second pursestring suture (not shown) may also be used as described in the text to seal the posterior rectus sheath. (Modified from Alexander SR, et al. Clinical parameters in continuous ambulatory peritoneal dialysis for infants and children. In: Moncrief JW, Popovich RP, eds. *CAPD update*. New York, NY: Masson, 1981.)

3. APD cyclers have facilitated PD in young patients, and all available cyclers permit sufficiently small exchange volumes to be used even in infants. Pediatric cycler tubing is available for some models of cyclers; it helps reduce dialysis inefficiency due to

dead space in the tubing, which is an important consideration with very small dwell volumes (<200 mL).

D. Chronic peritoneal dialysis prescription

1. **Continuous ambulatory peritoneal dialysis (CAPD).** The technique for performing CAPD in the pediatric patient is similar to that in adults. Fill volumes are determined by patient comfort, but most children can tolerate 40–50 mL/kg or 800–1,100 mL/m² without discomfort or leakage once their catheter exit site is well healed, although this may require assessment of intraperitoneal pressure. The choice of glucose concentration depends on ultrafiltration needs (fluid intake minus urine output and insensible losses).
 - a. Kinetic modeling of CAPD as Kt/V -urea and creatinine clearance has been performed in children; however, outcome data to define adequate clearance are not available. The NKF KDOQI (2006 update) recommendation for adequate CAPD in children is a weekly Kt/V -urea of 1.8 per week; if residual renal function contributes to this clearance, it should be measured regularly. Collections of effluent dialysate and residual urine output (in continent patients with normal bladder function) are used to ensure that target clearance values are being achieved and that loss of kidney function is not compromising the adequacy of therapy. Patients unable to perform urine collections should be assumed to have no residual GFR to avoid inadvertent underdialysis. Many patients can achieve acceptable clearance and ultrafiltration with four exchanges per day; some will require more. The risk of noncompliance with the dialysis prescription and missing exchanges increases as the task of dialysis becomes more burdensome and intrudes on usual family activities.
2. **APD** is well suited for chronic PD in children, accommodating their efficient solute exchange and higher risk of peritonitis. APD can be performed without a daytime dwell (nightly intermittent peritoneal dialysis, NIPD), with a daytime dwell (continuous cycling peritoneal dialysis, CCPD), or with a daytime dwell and midday exchange if solute clearance or fluid removal necessitate. The daytime dwell is recommended to improve middle molecule clearance in those patients without residual renal function. NIPD may allow improved nutritional intake and decrease the risk of hernia formation, but clearance will likely be adequate only in patients with high or high-average transport as measured by PET or those with residual renal function. The day dwell of CCPD may allow one to shorten nightly treatments (desirable in older children) or improve clearance for low and low-average transporters; yet high transporters usually absorb most of their long dwell if it is left in all day. The initial prescription is guided by transport characteristics determined by PET, typically ranging from four to eight exchanges per night with dwell times of 45 minutes to 2 hours.
 - a. **Kinetic modeling.** Although kinetic modeling of PD delivery has been performed in children treated by CCPD and NIPD, outcome data to define adequate clearance are not available. Target clearance (peritoneal and renal) is the same as for CAPD, a weekly Kt/V -urea of 1.8. Dialysate and urine collections are performed to assess the actual delivered dialysis dose at a given prescription. Collections are repeated whenever the prescription is changed and at regular intervals to assess

changes in residual renal function and peritoneal transport function. In practice, young children with PET-defined high or high-average permeability peritoneal membranes can almost always exceed these values, particularly if there is residual renal function. Older children with low-average permeability peritoneal membranes and without residual renal function often require a midday exchange to achieve acceptable clearances.

3. **Tidal dialysis** is used in children; it can enhance clearance in patients with borderline values for Kt/V who might otherwise need to change modalities. Children with abdominal pain at the end of a drain may be more comfortable using tidal dialysis with less frequent complete drains. Tidal therapy is unwise in infants because of the risk of overfilling of the abdomen with respiratory compromise when the child cannot alert caregivers to distress.

E. **Chronic hemodialysis.** Chronic hemodialysis is the appropriate modality for children and families not capable of providing reliable home care. Furthermore, large adolescents with low-permeability peritoneal membranes may not achieve adequate clearance on PD without a burdensome exchange schedule, and such adolescents are appropriate candidates for hemodialysis. Because hemodialysis treatments take children out of usual activities (school and play), a hemodialysis unit must provide intensive nursing, tutoring, and play therapy during dialysis treatments.

1. **Hemodialysis equipment**

- a. **Vascular access.** Vascular access remains a major limitation to successful hemodialysis in small children. Placing and maintaining permanent accesses in small vessels requires experienced and dedicated surgeons and radiologists. Vascular catheters can be placed by interventional radiologists or surgeons depending on the best experience available in an institution. A conservative strategy for permanent access is critical because of the lifelong need for renal replacement therapy. Some young adults leave pediatric dialysis units after many years of hemodialysis treatments (with interval failed renal transplants), and one must ensure they have not depleted all options for long-term vascular access.

1. **Catheters** (Table 37.2). Available double-lumen hemodialysis catheters range from 7 F to 14 F in lengths appropriate for small children through older adolescents. Both temporary and permanent catheters are available, and precurved models for internal jugular cannulation are available in larger sizes. The catheter tip should be radiologically positioned in the junction of the superior vena cava and right atrium.

In small infants and neonates, single-lumen catheters may be more appropriate considering vessel size. In neonates, a catheter can be inserted into the vena cava through the umbilical vessel if the vessel is still patent. Most of these catheters can be left in place for several weeks.

2. **Fistulas and grafts.** In older children, creation of an arteriovenous fistula between the radial artery and cephalic vein in the nondominant arm with an end-to-side anastomosis is a common mode of vascular access. When blood vessel size is too small for constructing an adequate fistula, a polytetrafluoroethylene

(GoreTex or Impra) graft can be placed between an extremity artery and vein. Children with myelomeningocele may prefer a graft placed in the thigh because of absent sensation if the vasculature is sufficiently developed to support that. Lower extremity grafts allow unimpeded play or schoolwork during dialysis treatments, but risk leg edema and hypertrophy.

3. **Blood flows.** Desired blood flow rate is targeted to urea clearance specifications for a chosen dialyzer. In a patient with advanced uremia, an initial urea clearance of 3 mL/min per kg is prudent to avoid symptomatic disequilibrium; higher urea removal rates are usually tolerated after the first few treatments. Smaller blood vessels cause higher venous resistance than in adults, which eventually limits flow, typically in the range of 50–150 mL/min in small children and 200–350 mL/min in older children. Small catheters often limit flow to 25–100 mL/min because of limited arterial inflow.
 - b. **Dialyzers.** A limited listing of dialyzers that may be appropriate for small patients is provided (Table 37.1).
 - c. **Blood lines.** Appropriately sized blood lines allow control of circuit volume. If the volume of the entire extracorporeal circuit exceeds 10% of the patient's blood volume (>8 mL/kg), a warmed blood (or albumin) prime is usually given to ensure hemodynamic stability. Small volume blood lines have become more difficult to find in an era of integrated hemodialysis machines. If small volume lines are chosen, it is important that the blood pump be properly calibrated for the chosen lines. Neonatal lines are not compatible with most currently available volumetric dialysis machines.
 - d. **Dialysis solution.** Bicarbonate dialysis solution is standard for pediatric hemodialysis; it provides better hemodynamic stability and fewer intradialytic symptoms. Patients with small muscle mass will be unable to metabolize a large acetate load quickly.
 - e. **Dialysis machines.** Dialysis machines that provide volumetric ultrafiltration control are required. Small errors in ultrafiltration volume (of a few hundred milliliters) may cause symptomatic hypotension or chronic volume overload. Blood flows must be accurate within the range of 30–300 mL/min, and the blood pump calibrated to different size lines.
2. **Hemodialysis prescription.** Small patients require a cautious approach to avoid disequilibrium by targeting urea clearance of 3 mL/min per kg, which is calculated from the specifications of the chosen dialyzer and the blood flow attainable through the patient's access. Early treatments may be programmed even more slowly if the patient is very uremic; repeated short treatments are usually advisable during initiation of hemodialysis when the BUN is extremely elevated. Once a stable, chronic dialysis prescription is attained, more efficient urea clearance is usually well tolerated, and fluid removal is more often a cause of intradialytic symptoms. With conditioning and distraction, most children can tolerate hemodialysis sessions lasting 2–4 hours.
 - a. **Anticoagulation.** The strategy for heparin administration to infants and children is similar to that for adults. Clotting is infrequent when the ACT is prolonged to

approximately 150% of the population baseline value. A “low-dose” heparin protocol would be used to prolong the clotting time to 125% of the population baseline value. The initial loading dosage is usually 10–20 units/kg, with higher dosages being used for infants and children weighing <15 kg. The initial maintenance heparin infusion rate (for the first 20–30 minutes) can be set at 0.3–0.5 units/kg/min, with further adjustments based on changes in the ACT. Low molecular weight heparin has been used in children receiving chronic hemodialysis. Heparin-induced thrombocytopenia occurs in children, and anticoagulation has been successful with danaparoid, hirudin, and argatroban, although published reports are few.

In older children, heparin-free dialysis can be performed successfully. Different dialyzer membrane types have not been systematically compared with regard to clotting. Clotting will be more likely in smaller children, in whom the blood flow rate is usually low relative to the size of the dialyzer. Intermittent saline flushes of the dialysis circuit will result in excessive volume administration in small children unless removal of excess fluid by ultrafiltration is carried out simultaneously.

- b. **Kinetic modeling of hemodialysis.** Formal three-point urea kinetic modeling of hemodialysis has been performed in children, and results are useful in assessing the efficiency of the dialysis treatment as well as dietary protein intake (as a function of urea generation rate) during the interdialytic period. Recommended dietary protein intake in children is greater than that in adults, and the long-term effects of inadequate intake on growth and neurologic development are of even greater concern. The technical aspects of kinetic modeling are discussed in Chapter 3 and are applied similarly in children. The slow-flow technique for blood sampling is important for accurate measurement, and the duration of slow flow is determined by the volume of the blood line from the needle or catheter to the sampling port. Pediatric blood lines can be adequately cleared by a slow-flow rate (60 mL/min) for 17 seconds; we predict infant lines will require 12 seconds at a slow-flow rate of 20 mL/min. The greater reliance on catheters in pediatric dialysis raises concern that recirculation will diminish treatment efficiency.
- c. **Adequacy of hemodialysis.** When small patients receive efficient clearance (i.e., relatively high K/V), there is a greater amount of postdialysis urea rebound with reequilibration of urea from either the intracellular space or relatively underperfused tissues. Thus, single-pool modeling overestimates dose of dialysis and urea generation rate. The NKF KDOQI 2006 recommendation in adults is for a minimum delivered dialysis dose of a single-pool $Kt/V = 1.2$. The guidelines recommend using single-pool Kt/V to guide therapy, but to increase the minimum dose for smaller patients, including children. A minimum sp Kt/V value of 1.4–1.5 would seem to be appropriate for children, and in practice, such a minimum value is easily achievable. Equilibrated Kt/V is recommended by the European Best Practice Guidelines, and this can be derived from single-pool Kt/V and the rate of dialysis using the Tattersall equation described in Chapter 3. Yet another approach

is to extrapolate from a postdialysis sample taken 15 minutes after dialysis (Goldstein, 1999). Whether $spKt/V$ or equilibrated Kt/V is used to target dose, it is prudent to err on the side of providing more therapy when treating this vulnerable population. Small children have a high surface area to total body water ratio, and alternative scaling of hemodialysis dose to body surface area would require even higher doses of Kt/V (Daugirdas, 2010). Residual renal function can significantly impact the hemodialysis prescription, especially in very small patients. Regular measurements are needed to ensure overall treatment adequacy as the GFR falls. If patients are unable to perform urine collections, they should be assumed to have no residual GFR to avoid inadvertent underdialysis.

d. **Complications**

1. **Disequilibrium and seizures.** Infants and small children develop seizures as a manifestation of the disequilibrium syndrome more commonly than adults. For this reason, the blood flow rate and session length are usually limited for the first few treatments. Overly rapid urea removal is generally avoided by choosing an appropriately sized dialyzer and blood flow rate to provide 3 mL/min per kg urea clearance for the initial treatments; often, blood flows are limited by the caliber of the dialysis access. Other measures sometimes utilized to help prevent disequilibrium syndrome include keeping the dialysate sodium at or slightly above the plasma level and the prophylactic infusion of mannitol (0.5–1.0 g/kg body weight) during the hemodialysis session.
2. **Hypotension.** Intradialytic hypotension and cramping with fluid removal >5% of body weight are common, yet interdialytic weight gains can be large in anuric children on largely liquid diets and in noncompliant adolescents, resulting in sustained interdialytic hypertension. Volume removal must be closely monitored because blood pressure is normally lower in children than in adults and there is a narrower margin to hypotension. Infants and very young children are prone to precipitous falls in blood pressure with no warning and no ability to communicate distress. Isolated ultrafiltration or lower dialysate temperature may make fluid removal more tolerable. If hypoalbuminemia is present, intravenous albumin infusion (0.5–1.5 g/kg) will increase oncotic pressure and may permit ultrafiltration. Repeated treatments may be the only way to remove fluid safely, and small children often require four or five treatments per week for fluid and blood pressure management.
3. **Hypothermia with isolated ultrafiltration.** If warmed dialysis solution is not circulated, then the extracorporeal blood circuit will function as a radiator, cooling the blood and the child. Body temperature should be monitored throughout dialysis, especially during isolated ultrafiltration.

III. CARE OF THE PEDIATRIC ESKD PATIENT

- A. **Nutrition.** Comprehensive nutritional management is important for the achievement of growth and physical development through ESKD. The recommended energy intakes for pediatric dialysis patients depend on their ages and should be the same as the estimated energy

requirement (EER) for their nonuremic counterparts. For infants, the EER for energy is approximately 100 kcal/kg per day. Such high intakes usually require supplementation, and gavage feeding is standard practice to avoid undernutrition and growth failure. In older children, obesity has become a greater concern and can adversely affect posttransplant outcomes; thus nutrition counseling in this age group will be markedly different than in infants and toddlers.

Protein requirements for children depend on their age and are greater than those in adults. The daily recommended intake (DRI) of protein for pediatric dialysis patients is the same as that for their nonuremic counterparts plus an estimate of amino acids and protein lost through dialysis. There is an emphasis on the early use of supplements, both orally and through gastrostomy tubes. There is limited experience with the use of amino acid-containing PD fluids, although individual patients have been treated for up to a year.

Supplementation of water-soluble vitamins is routine practice for children treated with chronic PD or hemodialysis. Fat-soluble vitamins should not be supplemented as clearance of vitamin A metabolites is impaired, risking hypervitaminosis A; an appropriate multivitamin not containing vitamin A must be selected.

It is difficult to impose fluid, sodium, phosphate, and potassium restrictions on pediatric patients; however, such restrictions may be unnecessary when PD is the treatment modality. Potassium and phosphorus binders are almost always required for adolescents, yet some infants receiving efficient dialysis will require supplementation. For hemodialysis patients, restrictions depend on the amount of residual urinary output, but always require individual dietary guidance to achieve stringent fluid, sodium, and potassium intake. Infants pose a particular challenge; daily fluid intake in an anuric infant on hemodialysis should be limited to 400–500 mL/m², and formula should be concentrated and appropriately supplemented to achieve nutritional goals. However, polyuric infants will require supplemental fluid and sodium to maintain volume status and permit growth.

Enteral feeding supplements designed for adults should be used cautiously in young children. Fortunately a whey-based infant formula lower in phosphorus and potassium is available; infants with formula allergies and intolerances present special challenges. Oral hypersensitivity and food avoidance are common in infants and young children, and carefully timed solid food introduction with speech therapy is usually necessary.

B. Hypertension. Hypertension is a particular concern given the accelerated rate of cardiovascular disease in children with CKD. Attention is directed to the maintenance of normal volume status and age-appropriate blood pressure. High blood pressure in children undergoing PD is usually the result of incorrect dialysate glucose concentrations chosen at home coupled with excessive sodium and fluid intake; it is usually managed with dietary counseling, parent education, and close monitoring of weight and blood pressure at home. In hemodialysis patients, hypertension may be the result of inadequate fluid removal during dialysis and nonadherence to sodium and fluid restrictions. In patients who remain hypertensive despite increased dialysis time, lowered dialysate temperature or isolated ultrafiltration may make volume removal more tolerable. Dietary and psychological counseling for the patient and family are advisable in cases of repeated nonadherence as this may reflect more serious difficulties in coping with the chronic disease process. Some

patients remain hypertensive despite apparent euvolemia, and antihypertensive medications are indicated. All antihypertensive agents typically prescribed for adults have been used successfully in pediatric dialysis patients, and doses should be titrated to age-appropriate blood pressure targets and reassessed frequently.

- C. **Anemia.** Children undergoing hemodialysis tend to be anemic more often than adults and have a lower hemoglobin at the initiation of dialysis. Children respond well to erythropoietin; the indications, route of administration, and potential complications are similar for children and adults. Dosage per kilogram is often higher in very young children (150–300 units/kg per week) than in adults. Iron deficiency and repeated episodes of peritonitis adversely affect the erythropoietin response, and nonadherence to home therapy is occasionally a problem. Iron supplementation, either intravenous or oral, is usually necessary in pediatric ESKD patients; blood loss in the hemodialysis circuit is an important cause of iron deficiency in very small patients, especially when more than three treatments per week are prescribed. Androgen therapy, rarely used in adults, is contraindicated in prepubertal children because it will lead to premature closure of epiphyses.
- D. **Growth.** Few longitudinal studies describing growth in pediatric patients undergoing CAPD or APD have been undertaken. Initial data comparing growth with CAPD or APD with that obtained with hemodialysis seemed to favor the PD approach; however, definitive controlled studies have not been performed. In children undergoing CAPD or APD, improvement in growth has been linked to a reduction in the degree of secondary hyperparathyroidism. Others have attributed better growth with CAPD or APD to improved nutritional intake, but increasing energy intake much above the EER will not usually be of benefit.
1. **Recombinant human growth hormone (rhGH) therapy.** There is evidence that rhGH treatment increases growth rate in children receiving chronic dialysis, although not as effectively as in children with nondialysis CKD. The usual dosage is 0.05 mg/kg per day or 30 IU/m² per week as a nightly subcutaneous injection, although other dosing strategies have been used. Slipped capital femoral epiphyses and worsening of metabolic bone disease may occur with rhGH; secondary hyperparathyroidism should be controlled prior to initiation of therapy. Growth hormone therapy is often paused at the time of renal transplantation, and growth velocity reassessed with a functioning allograft. Glucocorticoid minimization or withdrawal is integral to successful growth after transplant.
 2. **Acidosis.** Metabolic acidosis is common in children with ESKD and is more problematic in those receiving hemodialysis than those treated with PD. Chronic acidosis may impair growth by affecting bone mineralization through the growth hormone/insulin-like growth factor-1 axis, as well as exerting a catabolic effect on lean body mass. Some pediatric patients benefit from oral sodium bicarbonate or sodium citrate therapy or higher dialysate bicarbonate concentrations to maintain a serum bicarbonate concentration ≥ 22 mmol/L.
 3. **Renal osteodystrophy.** Renal osteodystrophy can be ameliorated in children undergoing dialysis treatment by good control of serum calcium, phosphorus, bicarbonate, intact

parathyroid hormone, and alkaline phosphatase levels. Calcitriol and vitamin D analogs are used to treat hyperparathyroidism and associated bone disease. There are small series reporting the use of cinacalcet in children, but there is little guidance regarding dosing or outcomes in the youngest patients. Hyperphosphatemia should be controlled by dietary manipulation and by oral administration of phosphate binders to an age-appropriate serum phosphorus level. Phosphorus intake is targeted at or below the DRI for age with greater restriction in patients with hyperphosphatemia or hyperparathyroidism. Calcium carbonate and calcium acetate have long been used as phosphate binders, but sevelamer is a good choice even in infants and young children because of a greater awareness of the risks of calcium overload and recognition of early cardiac calcification in adolescents and young adults with ESKD. Calcium acetate is available in a liquid formulation, and sevelamer is available in powder, which have facilitated dosing in infants and young children. The use of aluminum-containing phosphate binders should be avoided in infants and young children with CKD because of bone and neurotoxicity. There are no long-term data on the safety of lanthanum in children.

References and Suggested Readings

- Ashkenazi DJ, et al. Continuous renal replacement therapy in children ≤ 10 kg: a report from the prospective pediatric continuous renal replacement therapy registry. *J Pediatr*. 2013;162:587–592.
- Canepa A, et al. Use of new peritoneal dialysis solutions in children. *Kidney Int*. 2008;73:S137–S144.
- Daugirdas JT, et al. Dose of dialysis based on body surface area is markedly less in younger children than in older adolescents. *Clin J Am Soc Nephrol*. 2010;5:821–827.
- Dolan NM, et al. Ventriculoperitoneal shunts in children on peritoneal dialysis: a survey of the International Pediatric Peritoneal Dialysis Network. *Pediatr Nephrol*. 2013;28:315–319.
- Fischbach M, Warady, B. Peritoneal dialysis prescription in children: bedside principles for optimal practice. *Pediatr Nephrol*. 2009;24:1633–1642.
- Furth SL, et al. Peritoneal dialysis catheter infections and peritonitis in children: a report of the North American Pediatric Renal Transplant Cooperative Study. *Pediatr Nephrol*. 2000;15:179–182.
- Goldstein SL, et al. Evaluation and prediction of urea rebound and equilibrated Kt/V in the pediatric hemodialysis population. *Am J Kidney Dis*. 1999;34:49–54.
- Goldstein SL, et al. Quality of life for children with chronic kidney disease. *Semin Nephrol*. 2006;26:114–117.
- Gorman G, et al. Clinical outcomes and dialysis adequacy in adolescent hemodialysis patients. *Am J Kidney Dis*. 2006;47:285–293.
- Hackbarth RM, et al. Zero balance ultrafiltration (Z-BUF) in blood-primed CRRT circuits achieves electrolyte and acid-base homeostasis prior to patient connection. *Pediatr Nephrol*. 2005;20:1328–1333.
- Kidney Disease Improving Global Outcomes. Clinical practice guideline for chronic kidney disease-mineral and bone disorder (CKD-MBD). *Kidney Int*. 2009;76(suppl 113):S1–S130.
- Kidney Disease Improving Global Outcomes. Clinical practice guideline for acute kidney injury.

Kidney Int. 2012;2(suppl 1):1–138.

- Kramer AM, et al. Demographics of blood pressure and hypertension in children on renal replacement therapy in Europe. *Kidney Int.* 2011;80:1092–1098.
- Mendley SR. Acute dialysis in children. In: Henrich WL, ed. *Principles and Practice of Dialysis*, 4th ed. Philadelphia, PA: Lippincott Williams & Wilkins; 2009:641–652.
- Monagle P, et al. Antithrombotic therapy in children: the Seventh ACCP Conference on antithrombotic and thrombolytic therapy. *Chest.* 2004;126(suppl 3):645S–687S.
- National Kidney Foundation. KDOQI clinical practice guidelines for hemodialysis adequacy, update 2006. Guideline 8. Pediatric hemodialysis prescription and adequacy. *Am J Kidney Dis.* 2006;48(suppl 1):S45–S47.
- National Kidney Foundation. KDOQI clinical practice guidelines for peritoneal dialysis adequacy, update 2006. Guideline 6. Pediatric peritoneal dialysis. *Am J Kidney Dis.* 2006;48(suppl 1):S127–S129.
- Rees L, et al. Growth in very young children undergoing chronic peritoneal dialysis. *J Am Soc Nephrol.* 2011;22:2303–2312.
- Schaefer F, et al. Peritoneal transport properties and dialysis dose affect growth and nutritional status in children on chronic peritoneal dialysis. Mid-European Pediatric PD Study Group. *J Am Soc Nephrol.* 1999;10:1786–1792.
- Shmitt CP, et al. Effect of the dialysis fluid buffer on peritoneal membrane function in children. *Clin J Am Soc Nephrol.* 2013;8:108–115.
- Smye SW, et al. Paediatric haemodialysis: estimation of treatment efficiency in the presence of urea rebound. *Clin Phys Physiol Meas.* 1992;13:51–62.
- Sutherland SM, et al. Fluid overload and mortality in children receiving continuous renal replacement therapy: the prospective pediatric continuous renal replacement therapy registry. *Am J Kidney Dis.* 2010;55:316–325.
- Symons JM, et al. Continuous renal replacement therapy with an automated monitor is superior to a free-flow system during extracorporeal life support. *Pediatr Crit Care Med.* 2013;14:e404–e408.
- Warady B, et al. *Pediatric Dialysis*. Dordrecht: Kluwer Academic; 2004.
- Warady BA, et al. Consensus guidelines for the prevention and treatment of catheter-related infections and peritonitis in pediatric patients receiving peritoneal dialysis: 2012 update. *Perit Dial Int.* 2012;32(suppl 2):S32–S86.

Web References

- North American Pediatric Renal Trials and Collaborative Studies Annual Dialysis: <https://web.emmes.com/study/ped/annlrept/annualrept2011.pdf>.
- Pediatric Continuous Renal Replacement Therapy website: <http://www.pcrct.com/>.

In end stage kidney disease (ESKD) patients, mortality due to cardiovascular disease (CVD) is 10 to 30 times higher than in the general population. For example, a 30-year-old dialysis patient has a similar CVD mortality risk to that of an 80-year-old in the general population. This increased risk likely reflects the very high prevalence of CVD, increased prevalence and severity of diabetes, hypertension and left ventricular hypertrophy, and nontraditional risk factors such as chronic volume overload, hyperphosphatemia, anemia, oxidant stress, and other aspects of the uremic milieu (Table 38.1). In this chapter, we focus on epidemiology and management of traditional and nontraditional CVD risk factors, and on ischemic heart disease, heart failure, pericardial effusion, valvular disease, and arrhythmia.

I. TRADITIONAL RISK FACTORS

- A. **Blood pressure.** Data on blood pressure targets and optimal strategies and agents for blood pressure management in dialysis remain insufficient (Inrig, 2010). These are discussed in further detail in Chapter 33.
- B. **Diabetes.** Dialysis patients with diabetes are at higher risk for acute coronary syndromes and have worse outcomes following coronary interventions than those without diabetes. Additionally, there is increased prevalence of heart failure. Poor blood glucose control (as assessed by glycosylated hemoglobin levels) is associated with increased mortality in dialysis patients, although precise targets remain uncertain. Cohort data suggest that a hemoglobin A1C threshold of 8% may be a reasonable target in healthier dialysis patients for cardiovascular risk reduction (Ricks, 2012), while less stringent targets may be appropriate in those with more extensive comorbidity. See Chapter 32.
- C. **Smoking.** Smoking is associated with progression in early stage CKD patients, and may well adversely impact residual kidney function in dialysis patients. Smoking strongly associates with all-cause mortality in dialysis patients and likely associates with CVD. Critically, in USRDS data, former smokers had a similar risk as lifelong nonsmokers, suggesting a benefit of smoking cessation and a role for directed intervention.

Traditional Risk Factors	Nontraditional Risk Factors
Older age	Extracellular fluid volume overload
Male gender	Abnormal calcium/phosphate metabolism
Hypertension	Vitamin D deficiency
Diabetes	Anemia
Smoking	Oxidant Stress
Dyslipidemia	Inflammation
Left ventricular hypertrophy	Homocysteine
Physical inactivity	Malnutrition
Menopause	Albuminuria
Family history of cardiovascular disease	Thrombogenic factors
	Sleep disturbances
	Altered nitric oxide/endothelin balance
	Marinobufagenin
	Uremic toxins

D. Dyslipidemia

1. **Lipid profile patterns.** Dyslipidemia is very common in all stages of kidney disease, including both hemodialysis and peritoneal dialysis patients. Dyslipidemia, particularly high low-density lipoprotein (LDL) cholesterol and high triglyceride levels, is particularly common in peritoneal dialysis, where the glucose-enriched milieu predisposes to a more atherogenic lipid profile. In dialysis, similar to many advanced chronic disease states, the relationship of total or LDL cholesterol to mortality is “U”-shaped; patients with high cholesterol levels, likely due to increased atherogenic risk, and also patients with low levels, likely due to associated malnutrition, both are at heightened risk (Kilpatrick, 2007). Total cholesterol and, in particular, high-density lipoprotein (HDL) cholesterol levels may be reduced, and atherogenic lipoprotein remnants and lipoprotein (a) are often increased.

Nearly one-third of dialysis patients have hypertriglyceridemia, defined by levels above 200 mg/dL (2.26 mmol/L), with levels occasionally 600 mg/dL (6.8 mmol/L) or higher. The predominant underlying cause is a deficiency of lipoprotein lipase, resulting in reduced lipolysis of triglyceride (TG)-rich very low-density lipoproteins (VLDL) and yielding high quantities of atherogenic remnant lipoproteins. Enrichment of LDL particles with triglycerides also suggests partial deficiency of hepatic lipase. These basic defects may be enhanced by β -adrenergic blockers, high-carbohydrate diets, absorption of glucose from peritoneal dialysate, the use of heparin, and decreased hepatic blood flow from cardiac disease.

2. **Measurement.** If not previously assessed, it is likely worthwhile to evaluate a lipid profile at least once in all dialysis patients. This can establish a diagnosis of severe hypercholesterolemia or hypertriglyceridemia (i.e., 1,000 mg/dL [11.3 mmol/L] or higher) that may prompt focused treatment or evaluation for secondary causes of dyslipidemia (Miller, 2011). Lipid panels are optimally obtained in the fasting state, particularly for evaluation of serum triglyceride levels, although, as many dialysis patients receive treatments in the afternoon or evening and data on therapy efficacy are

limited, a random screening may be most practical.

The current KDIGO lipid guideline, similar to the recent American Heart Association guideline, notes limited data to support dose escalation of lipid-lowering therapies and therefore favors a “fire-and-forget” strategy (KDIGO Lipid Work group, 2013). Accordingly, in patients already treated with a high potency statin, there is no indication to routinely measure cholesterol. Similarly, in dialysis patients not currently treated with a statin, given the data discussed below on statin efficacy for CVD prevention, there is no indication to routinely measure cholesterol.

3. Treatment

- a. **Principles.** Treatment strategies for dyslipidemia include medications and lifestyle modifications. As in the general population, first-line therapy for most patients is dietary and lifestyle modification, including exercise whenever feasible. While the utility of lifestyle modifications for changing the lipid profile remains uncertain, there is little drawback to this strategy, particularly given other potential benefits, minimal risk, and a lack of benefit on hard outcomes associated with pharmacologic therapy.

Dietary prescriptions are best accomplished with guidance from a nutritionist with experience in management of kidney disease patients. Recommendations listed in Chapter 31 should generally be followed. These include consumption of a diet containing about 25%–35% of total calories as fat; of this, about 20% should be monounsaturated, 10% polyunsaturated, and <7% saturated fat. In patients with hypertriglyceridemia, mild restriction of total carbohydrate intake and limitation of the use of refined carbohydrate may be indicated. Additionally, alcohol ingestion should be discouraged. Despite the risk of malnutrition in many dialysis patients, there may be a minority where overall calorie restriction is indicated to achieve ideal body weight, especially among those receiving peritoneal dialysis. In PD patients, sodium restriction may reduce the use of higher dialysate glucose concentrations; this would yield less glucose absorption and decrease the stimulus for hypertriglyceridemia (see Chapter 29). If possible, physical training and regular exercise are recommended as they may result in an improved cardiovascular risk profile and an improved sense of well-being.

- b. **Statin therapy.** Although dialysis patients are in the highest risk group for CVD events, several large clinical trials have failed to show a significant benefit with statin therapy, despite substantial LDL-C lowering with therapy in these trials. Accordingly, in contrast to the prior KDOQI guideline, the 2013 KDIGO Clinical Practice Guideline for Lipid Management in Chronic Kidney Disease suggests that statins or a statin/ezetimibe combination not be initiated in adults with dialysis-dependent CKD.

In incident dialysis patients already being treated with statin therapy, these medications likely should be continued. This conclusion is based on results from the Study of Heart and Renal Protection (SHARP), which enrolled not only dialysis patients but also more than 6,000 individuals with stage 3b and 4 CKD, more than 2,000 of whom progressed to require dialysis or kidney transplant. In

general, simvastatin/ezetimibe was continued during kidney replacement therapy, and, in analyses of SHARP participants who at baseline did not require dialysis, statin/ezetimibe therapy was associated with significant cardiovascular event reduction. As many of these individuals continued on therapy following dialysis initiation, it seems reasonable to continue statin therapy in individuals treated with statins at the time of dialysis initiation. Although there are no studies evaluating dialysis patients with an acute myocardial infarction (MI) who were not previously treated with a statin, it also seems reasonable to initiate statin therapy in those with a relatively good longer-term prognosis.

One area of insufficient knowledge is peritoneal dialysis (PD). SHARP included 496 PD patients, but, aside from SHARP, PD patients have not been included in clinical trials. In SHARP, there was a trend to a benefit with lipid-lowering therapy versus placebo in this subgroup. Similarly, in a post hoc analysis of the US Renal Data System observation Dialysis Morbidity and Mortality Wave 2 cohort that used propensity score matching, lipid-lowering therapy in PD patients was associated with a significantly reduced risk of all-cause and cardiovascular death.

In sum, based on available data, statins should be continued in those individuals already using these agents, with attention paid to dose and drug-drug interactions (Table 38.2). Additionally, in dialysis patients not previously prescribed a statin, in the opinion of the authors, statin treatment of those dialysis patients with longer life expectancies (i.e., individuals listed for transplantation) or those experiencing recent acute coronary syndromes may be appropriate. Given the paucity of data in peritoneal dialysis but physiology that suggests higher atherosclerosis risk, a “fire-and-forget” approach may also be beneficial in PD patients (Goldfarb-Rumyantzev, 2007).

While statin use is generally safe in the dialysis population, a number of medications increase blood levels of statins via co-metabolism by hepatic cytochrome P450 enzymes; these include calcineurin inhibitors, macrolide antibiotics, azole antifungal agents, calcium channel blockers, fibrates, and nicotinic acid, and are best documented with simvastatin. Potential drug–drug interactions should be assessed in each patient. Statins may cause myopathy, and the risk of myopathy may be increased in CKD. This is particularly apparent with concurrent use of fibrates, and this combination should be avoided in CKD.

TABLE

38.2

Lipid-lowering Medication Dose Adjustments for Reduced GFR

Agent	Dose Adjustment in Dialysis	Notes
Statins^a		
Atorvastatin	None	
Fluvastatin	↓ to 50%	Decrease dosage by half at GFR <30
Lovastatin	↓ to 50%	Decrease dosage by half at GFR <30

Pravastatin	No	Starting dose of 10 mg/d recommended for GFR <60
Rosuvastatin	↓	Decrease to a maximum of 10 mg/d at GFR <30; recommended starting dose is 5 mg/d
Simvastatin	See note	If GFR <10, start at 5 mg/d and use doses above 10 mg daily with caution; may interact with amlodipine and other calcium channel blockers

Bile Acid Sequestrants

Cholestyramine	No	Not absorbed
Cholestipol	No	Not absorbed
Colesevelam	No	Not absorbed

Fibrates^b

Bezafibrate	See note	Concurrent use of fibrates and statins contraindicated in advanced CKD.
Ciprofibrate	See note	
Clofibrate	See note	
Fenofibrate	See note	
Gemfibrozil	See note	

Miscellaneous

Ezetimibe	No	None
Nicotinic Acid	↓ to 50%	May worsen glycemic control and cause orthostasis, hyperuricemia, and flushing; may have phosphorus binding effects

^a Statins may interact with other medications used in dialysis patients, including calcineurin inhibitors, several antibiotics, and, potentially, calcium channel blockers.

^b Based on package inserts, all fibrates are contraindicated in dialysis patients. Small short-term studies have safely utilized fibrates in dialysis patients, with one study using gemfibrozil 600 mg twice daily and another using fenofibrate 100 mg daily without any serious adverse effects. The FIELD trial of 9795 patients with type 2 diabetes evaluated fenofibrate 200 mg daily versus placebo and noted no adverse safety signals in the 519 patient subset with stage 3 CKD.

- c. **Hypertriglyceridemia management.** Statins have some effect in lowering serum triglyceride level, although they are less effective than fibrates and/or nicotinic acid for this purpose. In contrast, bile acid resins may actually increase triglyceride levels. There are no data supporting a benefit of fibrates or nicotinic acid on outcome improvement in dialysis patients, particularly in those with only modest elevations in serum triglyceride level (<500 mg/dL [<5.7 mmol/L]), and these agents should not be first-line therapy in this setting. Based on this paucity of data, the 2013 KDIGO guidelines state that: “Fibric acid derivatives are not recommended to prevent pancreatitis or reduce cardiovascular risk in adults with

CKD and hypertriglyceridemia.” There are no data to guide treatment decisions in dialysis patients with very high TG levels (>500 mg/dL [>5.7 mmol/L]); accordingly, treatment decisions need to balance potential risks associated with severe hypertriglyceridemia with the risks and benefits associated with therapy. Of note, adequate data do not exist to guide fibrate dosing in dialysis patients as the safety of this class has not been assessed sufficiently in dialysis patients. Small studies and reports suggest that fibrates may be safe, although some dose reduction may be prudent if these agents are used in dialysis (Table 38.2) and concurrent use with a statin is contraindicated. Available fibrates include gemfibrozil, bezafibrate, ciprofibrate, clofibrate, and fenofibrate.

- d. **Other lipid-lowering agents.** Alternatives to statins and fibrates include bile acid sequestrants (including the phosphate binder, sevelamer), nicotinic acid, and ezetimibe. Bile acid sequestrants can interfere with absorption of other medications; bile acid sequestrants should not be used when triglycerides (TG) are >400 mg/dL (>4.5 mmol/L), and their use is relatively contraindicated when TG are >200 mg/dL (>2.3 mmol/L) since they may increase triglycerides in some patients. Doses do not need to be reduced in dialysis patients (Table 38.2). Sevelamer acts by the same mechanism to lower both total and LDL cholesterol, and may be a good choice when phosphorus binding is also desired. While not as effective for LDL lowering, nicotinic acid has the greatest favorable effects on HDL cholesterol levels of available drug therapies, and also lowers serum triglyceride levels. However, there are no data to support a benefit of nicotinic acid on CVD or mortality outcomes. Dosage should be reduced by about 50% in ESKD, given its substantial renal excretion. The potential of nicotinamide as a phosphorus binder has been advocated, but data are inadequate to support this indication. Adverse effects can include hyperglycemia and hepatotoxicity in individuals with underlying liver disease or when high doses are used. Flushing may be attenuated with concurrent aspirin use or by giving longer-acting preparations. Nicotinic acid is more often used as a first-line therapy when severe hypertriglyceridemia (>500 mg/dL, or 5.8 mmol/L) needs to be treated to protect against pancreatitis, or when a statin is contraindicated. Ezetimibe is a drug that inhibits cholesterol absorption. There are few data available on its use in kidney failure, although its use in conjunction with simvastatin in SHARP suggests safety.

E. **Left ventricular hypertrophy**

1. **Epidemiology.** Left ventricular hypertrophy (LVH) is highly prevalent, frequently developing prior to the need for kidney replacement therapy, and likely reflecting pressure and volume overload (KDOQI CVD, 2005). Over 30% of participants in the Frequent Hemodialysis Network studies, a group that overall was healthier than the general dialysis population, had LVH at study entry (defined using cardiac magnetic resonance imaging), with other studies showing prevalence rates of (50%–75%) patients. LVH in dialysis patients is an independent risk factor for subsequent adverse cardiovascular events and death.

Most LVH is initially concentric, representing a uniform increase in wall

thickness secondary to pressure overload from hypertension, stiffened blood vessels, or aortic stenosis. Anemia and volume overload resulting from chronic inability to effectively remove ingested sodium and fluid may each result in eccentric hypertrophy. The endpoint is often a dilated cardiomyopathy with eventual reduction in systolic function. These end-stage patients typically have low blood pressure and may be responsible for the “J”-shaped (or “U”-shaped) relationship observed between blood pressure and mortality in dialysis patients.

LVH most often is diagnosed with echocardiography, an inexpensive, noninvasive widely available test. Cardiac function should be assessed in the euvolemic state, as both significant volume depletion and overload may reduce left ventricular inotropy. Accordingly, in dialysis patients, two-dimensional echocardiography is likely to be most informative if performed on a day during the interdialytic interval. While three-dimensional echocardiography may be useful to assess left ventricle (LV) structure as it avoids the use of geometric assumptions of LV shape that are required to estimate LV mass and volume, the increasing availability of cardiac magnetic resonance imaging likely provides the most accurate assessment of LV structure. Screening echocardiography is currently recommended for incident dialysis patients; however, there is no evidence that this improves clinical outcomes.

2. **Prevention and management.** Some data suggest that with modification of risk factors, including anemia and systolic blood pressure, strict management of volume, management of mineral and bone disorder, and use of ACE inhibitor or angiotensin receptor blocker therapy, regression of LVH may occur in dialysis patients. Data are inconsistent on whether high flow arteriovenous fistulas may lead to maladaptive cardiac remodeling. That regression of LVH results in reduced CV events and decreased mortality risk appears likely, as multiple post hoc analyses have shown a lower risk of adverse events in participants in whom LVH regressed over the course of clinical trials. Accordingly, in dialysis populations, LVH has been used both as a factor in determining study eligibility and as a surrogate outcome to infer subsequent CV and mortality risk reduction.

With regard to RAAS inhibition, the largest outcomes study to date evaluating the effect of renin–angiotensin–aldosterone system blockade in dialysis patients with LVH was the Fosinopril in Dialysis Study which randomized 397 hemodialysis patients to fosinopril versus placebo, and showed no benefit on cardiovascular events over a 2-year period (Zannad, 2006). Other trials examining left ventricular mass reduction have, however, suggested a benefit. Randomized trials in CKD targeting normalization of hemoglobin levels with recombinant human erythropoietin had no effect on left ventricular mass. In hemodialysis patients enrolled in the Frequent Hemodialysis Network study, those who received more frequent hemodialysis had a significant improvement in LV mass; whether this benefit was mediated through improved control of blood pressure, volume, phosphorus, or other factors is uncertain.

II. **NONTRADITIONAL RISK FACTORS.** These are listed in Table 38.1. In-depth discussion of some of these is beyond the scope of the Handbook, but we briefly summarize the most pertinent

issues. Volume control is discussed in chapters 12, 26, and 33.

A. **Mineral and bone disorder.** Mineral and bone disorders, discussed in Chapter 36, may affect the cardiovascular system in multiple ways (Lau & Ix, 2013). First, both elevated PTH and reduced 1,25-vitamin D levels may directly affect the myocardium, promoting hypertrophy. Second, hyperphosphatemia, positive calcium balance in the setting of impaired bone buffering, and other factors in the uremic milieu including loss of calcification inhibitors can combine to promote vascular calcification. Third, other hormones, including FGF23, may promote LVH and may also act independently or through other calcification promoters to promote vascular calcification. Vascular calcification occurs at both the arterial media and the intima, with medial calcification generally more pronounced among dialysis patients. Medial calcification is associated with stiffer blood vessels, as evidenced by increased pulse wave velocity. This increases cardiac afterload and promotes LVH. Furthermore, during the cardiac cycle, the systolic pressure wave normally reflects back onto the heart during early diastole, promoting coronary filling. With stiffened arteries and increased pulse wave velocity, this reflected wave returns to the heart prematurely—during late systole. This results in loss of the coronary filling effect and increased afterload as the heart has to pump against the reflected pressure wave from the previous contraction.

Vascular calcification may be diagnosed in several ways. Plain radiographs are specific but insensitive, while electron beam and spiral computed tomography are sensitive and specific but expensive and associated with significant radiation exposure on repeated use. Ultrasound, most commonly of the carotid arteries, is relatively inexpensive and noninvasive, but requires a trained operator and may lack precision to closely track changes over time. Use of such tests needs to be justified by their impact on clinical decision making. At the present time, there is no reliable method of reversing cardiac calcification, although some studies have suggested that use of non-calcium-containing binders results in more favorable calcium balance. Dialysis prescriptions resulting in negative phosphorus balance also may slow progression of calcification. A reasonable strategy may be to limit the use of calcium-containing phosphorus binders in patients in whom extensive vascular calcification has been documented. This is discussed in more detail in Chapter 36.

B. **Anemia.** Anemia is common in CKD patients, especially at dialysis initiation, and its severity correlates with the extent of LVH. While in observational studies, patients with higher hemoglobin levels have fewer cardiovascular disease events, treatment with recombinant erythropoietin to raise hemoglobin levels to the normal range may be associated with increased cardiovascular risk. Anemia management is discussed in detail in Chapter 34.

C. **Sleep.** Sleep abnormalities, discussed in Chapter 40, are highly prevalent in dialysis patients and are associated with coronary artery disease. Nocturnal hypoxemia associated with sleep apnea is associated with increased CVD events and may represent a potentially modifiable risk factor.

D. **Oxidant stress and inflammation.** Numerous factors in the dialysis patient increase oxidant stress and inflammation burden. These include dialysis using catheters, underlying illness and infection, malnutrition, and perhaps the dialysis procedure itself. Many protective

mechanisms against inflammation are impaired, including reduced serum levels of free thiols such as glutathione. Retained, failed arteriovenous (AV) grafts, or kidney allografts also may be a source of continued inflammatory stimulus. At this time, specific treatment strategies to reduce inflammation or oxidant stress are neither widely used nor adequately supported by randomized trials, and results of studies investigating the potential benefit of antioxidant therapies in the dialysis population have been disappointing.

III. ISCHEMIC HEART DISEASE

- A. **Overview.** Acute myocardial infarction (MI) and acute coronary syndromes are exceedingly common in the ESKD population and associated with poor outcomes. One study in Taiwan demonstrated 30% 1-year mortality following acute coronary syndrome in dialysis patients, while US data show a 50% higher in-hospital mortality rate for dialysis patients admitted with acute MI (Herzog, 2007) and 1-year mortality of approximately 60%.

Both atherosclerosis and arteriosclerosis contribute to pathogenesis; arteriosclerosis, often synonymous with vascular stiffness and manifesting as a loss of arterial elasticity, may result in LVH with subsequent increased myocardial oxygen demand and altered coronary perfusion followed ultimately by subendocardial ischemia. Small vessel coronary artery disease also plays a role: in one study, up to 50% of nondiabetic dialysis patients with symptoms of myocardial ischemia did not have significant large caliber coronary artery disease, implicating isolated small vessel disease as a cause of ischemia.

- B. **Diagnosis.** Routine screening is not currently recommended for dialysis patients, and even screening of asymptomatic transplant candidates is controversial. There are no pre-operative screening guidelines specific to dialysis patients, and it is reasonable to use general population guidelines, recognizing that the extent of comorbid conditions prevalent in the dialysis population is likely to place them into the highest cardiovascular risk group. Because many dialysis patients are unable to achieve adequate exercise levels for valid stress tests, pharmacologic stress tests should be used in this population. Furthermore, because of the high incidence of baseline electrocardiogram abnormalities, either nuclear or echocardiographic imaging should be utilized in stress testing. There is no absolute contraindication to cardiac catheterization in patients treated with dialysis, although preservation of existing kidney function is an important consideration, especially in those treated with PD, and the associated risk of contrast nephropathy should be kept in mind.

Diagnosis of acute MI can be challenging, as cardiac biomarker levels, including troponins, may be elevated chronically (DeFilippi, 2003). Chronic troponin elevation itself is a marker of worse prognosis, likely representing ongoing injury and subclinical ischemia. The American Heart Association suggests that, if chronic, minor elevations in cardiac biomarkers in kidney failure should not be classified as injury; however, rising and/or falling cardiac biomarker levels in the appropriate clinical setting likely are consistent with acute MI (Thygesen, 2012).

- C. **Prevention.** There are few clinical trials evaluating primary and secondary prevention strategies in dialysis patients. If hemorrhagic risk and blood pressure permit, aspirin, β -blockers, ACE inhibitors or angiotensin receptor blockers, and nitrate preparations may all be appropriate for secondary prevention.

D. Treatment

1. **Management of angina pectoris and stable coronary artery disease.** The pharmacologic approach to angina in dialysis patients is likely similar to that in the general population. The progressive introduction of sublingual nitrates, oral long-acting nitrates, β -blockers, and calcium channel blockers is appropriate. Usual dosages of sublingual and oral nitrates can be given to dialysis patients.

While there is strong evidence for the benefits of aspirin for secondary prevention of atherosclerotic CVD events in individuals with intact kidney function and coronary artery disease, with or without ischemic cardiomyopathy, there are conflicting reports of worse heart failure outcomes associated with aspirin use in patients with kidney disease. This may relate to attenuation of the beneficial effects of ACE inhibitors due to aspirin-mediated inhibition of kinin-mediated prostaglandin synthesis. Limited observational data in dialysis patients have not shown a beneficial effect on cardiovascular outcomes associated with low-dose aspirin, but these reports are limited by study design. Clinical trials examining aspirin use and use of other antiplatelet agents for access patency show no evidence of harm associated with aspirin or clopidogrel use, but benefit remains uncertain. At this time, given the significant benefits of aspirin use in nondialysis patients with coronary artery disease, there is insufficient evidence to recommend against the use of aspirin in dialysis patients with coronary artery disease.

2. **Chest pain during the hemodialysis session.** For patients who develop chest pain primarily during the hemodialysis session, a number of potential therapeutic options are available. Nasal oxygen may be beneficial in this setting. If the anginal episode is associated with hypotension, initial treatment should include raising the blood pressure by elevating the feet and by cautiously administering saline. Sublingual nitroglycerin can be given if the blood pressure has increased to a clinically acceptable value. Possibly, the blood flow rate should be reduced and ultrafiltration should be stopped until the anginal episode subsides. Cooling the dialysate may also help maintain cardiac perfusion, particularly in individuals prone to intradialytic hypotension (Selby, 2006). Predialysis administration of 2% nitroglycerin ointment may be of benefit when applied 1 hour prior to a hemodialysis session, assuming that the blood pressure will tolerate this intervention. Predialysis administration of β -blockers and oral nitrates may be of benefit, but must be done cautiously because the risk of hypotension during the dialysis session may be increased. Of note, several β -blockers require dose reduction in dialysis patients, including atenolol, which has extensive kidney clearance. Among commonly used β -blockers, atenolol and metoprolol are extensively cleared with hemodialysis, while carvedilol and labetalol do not have substantial dialysis-related clearance. Calcium channel blockers could be of use in situations where β -blockade is contraindicated or inadequate; however, given the negative cardiac inotropy associated with this class and the high prevalence of systolic dysfunction in dialysis patients, calcium channel blockers, particularly the nondihydropyridines (diltiazem and verapamil), should be used with caution.
3. **Revascularization.** The optimal treatment of coronary artery disease in dialysis patients

remains uncertain. Medical management, percutaneous intervention (PCI) including angioplasty with use of either drug eluting or bare metal stents, and coronary artery bypass graft (CABG) surgery, all have roles in individualized care (Charytan, 2014).

Given the high periprocedural risks associated with CABG, if anatomy permits and symptoms persist despite medical management, PCI is likely the better approach for patients who are not transplant candidates or at higher perioperative risk if undergoing CABG. As in the general population, CABG incorporates greater short-term risk in exchange for longer-term benefits, and balancing this trade-off is essential to individualizing therapy. For PCI, data are insufficient to support drug eluting stents over bare metal stents, and a key determination for stent type may be whether an individual dialysis patient can safely use clopidogrel for 1 year or more; if longer-term clopidogrel use is an option, many interventionalists will select a drug eluting stent based on general population and early stage CKD data. As with most procedures, those done on an emergent basis are associated with worse outcomes. Thrombolytics and glycoprotein IIb/IIIa antagonists are likely beneficial, particularly when interventional cardiology is unavailable, but may be associated with a higher risk of bleeding complications.

IV. CARDIOMYOPATHY AND HEART FAILURE

A. **Pathophysiology.** Heart failure is highly prevalent and related to many common factors in the dialysis population. Although there is no universally accepted definition, heart failure is generally characterized by volume overload, pulmonary edema, and dyspnea. Heart failure may occur as a result of left ventricular dysfunction (systolic dysfunction) or diastolic dysfunction in which the LV has a normal ejection fraction but impaired filling. Diastolic dysfunction is often associated with LVH and systemic hypertension, both of which are extremely common in dialysis patients. Systolic dysfunction is frequently a result of ischemic disease and dilated cardiomyopathy. For obvious reasons, dialysis patients are particularly vulnerable to fluid overload, and pulmonary edema in the setting of marked fluid overload may not represent cardiac dysfunction. However, frequent pulmonary edema with minimal intradialytic weight gain may be an important clue of cardiac dysfunction. An additional clue may be dialysis-related hypotension, as dysfunctional hearts likely have reduced capacity for adaptation to intravascular volume loss. Furthermore, ultrafiltration may never allow accumulation of excess fluid, rendering hypotension the sole manifestation of heart failure.

Although the diagnosis of heart failure is clinical, echocardiography is invaluable for diagnosing systolic and diastolic dysfunction. Echocardiography may also suggest the cause of disease, identifying wall motion abnormalities that may indicate ischemia and infarcts, LVH that may predispose to diastolic dysfunction, and valvular disease with its effects on cardiac morphology. KDOQI guidelines recommend obtaining echocardiograms at dialysis initiation after dry weight is established and every 3 years thereafter; these recommendations are opinion-based (KDOQI CVD, 2005).

B. **Treatment.** Chronic therapy for heart failure in dialysis patients has not been adequately studied; therefore, most recommendations are either extrapolated from the general

population or based on smaller trials. Restriction of sodium intake, including avoidance of routine sodium modeling, is important, since, with most thrice-weekly hemodialysis schedules, the ability to remove excess fluid is limited. More frequent dialysis therapies, including daily hemodialysis and PD, may help optimize volume status. Maintaining a balance between fluid overload on the one hand and symptomatic hypotension on the other may be extremely difficult in some dialysis patients. In the future, newer technologies, including intradialytic blood volume monitoring and bioimpedance analysis, may have more clearly delineated roles for optimizing volume management. In general, we favor maintenance of near euvolemia over pharmacologic therapy in the treatment of heart failure in dialysis patients.

1. Traditional drug therapy

- a. **ACE inhibitors** are beneficial in nonuremic patients with chronic heart failure and may be beneficial in dialysis patients, with one prior meta-analysis showing a reduction in LV mass. There are limited data showing a survival benefit with these agents. One small Italian study did show a mortality benefit with dual ACE inhibitor and ARB therapy versus ACE inhibitor therapy alone in hemodialysis patients with a left ventricular ejection fraction below 40%, a strategy that is not routinely recommended (Cice, 2010). On the other hand, one relatively large randomized trial of olmesartan versus placebo failed to show any improvement in terms of cardiovascular event rate or death (Iseki, 2013). Major limitations associated with use of these agents include hypotension and hyperkalemia. If there is a contraindication to ACE inhibitor use, it seems reasonable to extrapolate from data in the general population and substitute angiotensin receptor blockers (ARBs). Most ACE inhibitors are cleared during dialysis while ARBs are not dialyzable.
- b. **α -Blockers**, another mainstay of heart failure therapy in the general population, also are of uncertain benefit in the dialysis population. In an Italian study, carvedilol, well studied for heart failure in the general population, reduced mortality in dialysis patients with left ventricular dysfunction (Cice, 2003). Carvedilol dosing is the same as in the general population. One small trial compared thrice weekly posthemodialysis administration of lisinopril with atenolol (Agarwal, 2014), with both groups having a similar reduction in LV mass, the primary outcome; of note, the group treated with atenolol had fewer deaths and heart failure hospitalizations, secondary outcomes for which the study was not powered. It is difficult to draw treatment conclusions from this study as the dosing intervals for lisinopril were very atypical for clinical practice. Several β -blockers, including atenolol, have markedly reduced elimination rates in kidney failure and should either not be used or be used at either a lower dose or increased dosing interval (Chapter 33). In general, non-kidney-metabolized β -blockers, such as metoprolol and carvedilol, can be safely titrated to heart rate and blood pressure. Dialysis clearance also varies for specific β -blockers, with atenolol and metoprolol both extensively cleared with high-flux hemodialysis while carvedilol and labetalol have minimal hemodialytic clearance.

- c. **Aldosterone blocking agents**, including spironolactone and epleronone, are beneficial in the general population with heart failure and, given the known effects of aldosterone on arterial stiffness and cardiac remodeling, could be beneficial in the dialysis population. With only one small trial suggesting a benefit on clinical outcomes with low-dose spironolactone (Matsumoto, 2014), use of these agents has not been adequately studied in the dialysis population for safety or efficacy. Despite the lack of substantial kidney function, of theoretical concern would be a possible increased risk of hyperkalemia, particularly if aldosterone antagonists were used in conjunction with ACE inhibitors or ARBs.
 - d. **Cardiac glycosides**, namely digoxin, are frequently used in heart failure in the general population, where it has been shown that they improve morbidity but not mortality. Digoxin, when used in dialysis patients, should be utilized judiciously with careful attention to dosage and drug levels. Maintenance dosing should begin at low doses (0.0625 mg or 0.125 mg) every other day. A loading dose generally should not be used. Care should be taken in complex drug regimens as many other medications affect digoxin levels.
2. **Role of arteriovenous (AV) fistulas and grafts.** Although forearm fistulas occasionally lead to a high output state, this problem is more often encountered with upper arm high flow fistulas, and close attention to the size of the AV fistula is an essential part of longitudinal dialysis patient care. Bradycardia during fistula or graft occlusion (by finger pressure) suggests that the AV shunt is importantly and pathologically contributing to an increased cardiac output (Branham's sign). The test is specific, but absence of bradycardia on fistula or graft occlusion by no means exonerates the AV communication as a cause of the heart failure. Although limited data exist implicating fistulas in clinically apparent heart failure, flow reduction procedures can be used to address potential concerns with high flow fistulas while maintaining fistula patency.
 3. **Carnitine.** Predominantly anecdotal evidence has suggested cardiovascular benefits with L-carnitine therapy at recommended intravenous doses of 20 mg/kg of total body weight following the dialysis procedure. Suggested indications for carnitine therapy have included anemia with extremely high erythropoietin requirements, intradialytic hypotension, and muscle weakness. L-carnitine has also been recommended for treatment of symptomatic cardiomyopathy with a documented impaired ejection fraction that has not responded adequately to standard medical therapy. Despite multiple suggested uses for L-carnitine, there are no strong data to support its utilization in dialysis at this time.

V. **PERICARDIAL DISEASE.** Pericardial disease most commonly manifests as acute uremic or dialysis-associated pericarditis although chronic constrictive pericarditis may also be seen. Most estimates of the clinical incidence of pericardial disease in prevalent dialysis patients are <20%.

A. **Uremic pericarditis.** Uremic pericarditis describes patients who develop clinical manifestations of pericarditis prior to or within 8 weeks of initiation of kidney replacement therapy. In the current era, uremic pericarditis is rare, but remains an indication for and

responds extremely well to initiation of kidney replacement therapy.

B. **Dialysis-associated pericarditis.** Dialysis-associated pericarditis is a syndrome that occurs after a patient is stabilized on dialysis and is more common than uremic pericarditis. The etiology of dialysis pericarditis remains unknown, but may be at least in part dependent on inadequate dialysis and volume overload. However, other causative factors are likely present, given that intensification of dialysis frequently does not result in resolution.

1. **Clinical manifestations and diagnosis.** The most common symptom of pericarditis is chest pain, generally pleuritic in nature exacerbated by reclining and reduced with leaning forward. Pericarditis may be accompanied by nonspecific symptoms, including fever, chills, malaise, dyspnea, and cough, with respiratory symptoms potentially reflecting a pericardial effusion. Physical examination may reveal a pericardial friction rub. When hemodynamically significant, pericardial disease accompanied by an effusion may be characterized by hypotension, particularly during hemodialysis. Jugular venous distension, elevated pulsus paradoxus, and distant heart sounds may also be present. Chest radiograph may reveal an enlarged cardiac silhouette that may be difficult to distinguish from LVH. Dialysis-related pericarditis often does not manifest with the classical electrocardiogram finding of diffuse ST segment elevation because there may only be minimal inflammation of the epicardium. Echocardiography is useful in identifying pericardial effusions, but effusions may be absent in patients who have adhesive, noneffusive pericarditis.

2. Treatment

- a. **Monitoring.** Small (<100 mL), asymptomatic pericardial effusions are fairly common in dialysis patients and require no acute intervention. Larger effusions present a risk for tamponade and need to be monitored closely using serial echocardiograms. Hemodynamic and even echocardiographic signs of impending tamponade are not always reliable.
- b. **Intensification of hemodialysis** is the mainstay of therapy, but is only effective approximately 50% of the time. This may be accomplished by increasing dialysis frequency to 5–7 days per week with careful attention to electrolytes, including phosphorus and magnesium, avoidance of over-alkalinization, and volume status. Heparin during dialysis has traditionally been avoided out of concern for hemorrhagic tamponade.
- c. **Adjuvant medical therapies**, including oral and parenteral glucocorticoids and nonsteroidal anti-inflammatory medications, have generally not been effective and are not indicated.
- d. **Surgical drainage.** Failure to recognize the need for timely surgical drainage of large pericardial effusions may have dire consequences for the patient as the onset of tamponade may be rapid and without premonitory signs. Hence, regular echocardiographic monitoring of the size of an effusion is vital. Surgical drainage by subxiphoid pericardiostomy should be strongly considered whenever the effusion size is estimated by echocardiography to exceed 250 mL (posterior echo-free space larger than 1 cm) even when hemodynamic compromise is absent. Surgical drainage is mandatory when overt tamponade appears. Subxiphoid

pericardiostomy is the surgical drainage procedure of choice (i.e., insertion under local anesthesia of a large-bore tube into the pericardial space). The tube is left in place to closed drainage for several days until drainage ceases. Instillation of locally acting steroids has not been proven necessary and increases the risk of infection. Pericardiocentesis using a blindly inserted needle is dangerous and never indicated except as an emergency therapy for patients with life-threatening tamponade. Pericardiocentesis is the most common method used for pericardial fluid removal and can be performed under fluoroscopic, echocardiographic, or CT guidance. Of note, hemorrhagic effusions are poorly evacuable through the needle. Anterior pericardiectomy has been favored by some, but general anesthesia and thoracotomy are unnecessary risks given the uniformly successful response to drainage by subxiphoid pericardiostomy.

- C. **Constrictive pericarditis.** Constrictive pericarditis can appear as an unusual complication of dialysis-associated pericarditis or as the first manifestation of pericardial disease. Constrictive pericarditis may also masquerade as congestive cardiac failure; the best means of differentiation is by right heart catheterization. Even then, the diagnosis may be in doubt and can be proven only by a favorable response to total pericardiectomy.
- D. **Purulent pericarditis.** Occasionally, patients are found to have purulent pericarditis as a complication of septicemia, often as a result of access site infection. These patients often require anterior pericardiectomy in addition to antimicrobial therapy.

VI. VALVULAR DISEASE

- A. **Endocarditis.** Infective endocarditis is a relatively common complication of hemodialysis. Venous hemodialysis catheters are prone to infection and endocarditis is a frequent complication of catheter-related bacteremia; the presence of cardiovascular implantable electronic devices may also be associated with an increased risk of endocarditis. An additional recently appreciated factor predisposing to endocarditis is cannulation of AV fistulas using a buttonhole technique. Endocarditis is relatively common in dialysis patients even without the above risk factors. The majority of cases are due to gram-positive organisms (*S. aureus*, *S. epidermidis*, and *Enterococcus*). The presence of underlying valvular disease including calcification may increase the risk. Prevention is focused on avoiding use of venous catheters as much as possible, prolonged antimicrobial therapy for staphylococcal bacteremia when it occurs, and reinforcement of proper vascular access technique, including exit site and cannulation site care. In many patients, acute bacterial endocarditis will complicate an already recognized episode of *Staphylococcus aureus* or other gram-positive bacteremia, and these bacteremias should be treated as presumed endocarditis.

Bacteremia therapy consists of an antistaphylococcal agent (nafcillin or its equivalent for methicillin-sensitive *S. aureus*, or vancomycin for methicillin-resistant *S. aureus*) with or without an additional agent for synergistic therapy (e.g., gentamicin, rifampin) for at least 4–6 weeks. First generation cephalosporins that can be dosed at hemodialysis are sometimes used to avoid the need for additional vascular access, recognizing the ongoing infection risks associated with vascular catheters as well as the need to preserve veins for

AV fistulas and grafts. Such prolonged antimicrobial therapy should help avoid the complication of valvular sequestration of infection in most patients with bacteremia diagnosed at an early stage.

1. **Symptoms and signs.** Dialysis patients with endocarditis usually, but not always, have fever. Murmurs, leukocytosis, and septic emboli may also be present; however, the clinical evaluation of murmurs may prove difficult because cardiac murmurs are common in the ordinary dialysis population owing to anemia, valvular calcification, and the presence of AV fistulas. Because a substantial percentage of dialysis patients are normally hypothermic, the body temperature with infection may be elevated to only slightly above the normal range or not at all.
2. **Diagnosis** is chiefly dependent on positive blood cultures and clinical suspicion. Transthoracic and, if echocardiography windows are limited, transesophageal echocardiography may be critical to making the diagnosis.
3. **Treatment** of endocarditis in hemodialysis patients will usually be directed at gram-positive organisms and regimens should be tailored to bacterial sensitivities. In general, empiric therapy in individuals with fever and a dialysis catheter will be initiated with vancomycin, because of both the high incidence of methicillin-resistant *S. aureus* and the ease of administration. Some practitioners will add empiric gram-negative coverage with an aminoglycoside or third generation cephalosporin. In the presence of methicillin-sensitive *S. aureus*, antistaphylococcal penicillins like nafcillin or first generation cephalosporins like cefazolin are preferable. In cases of severe *S. aureus* infection, other agents may be added for synergy, including aminoglycosides and rifampin. Care must be taken with aminoglycoside use due to the incidence of ototoxicity. Newer antistaphylococcal agents such as daptomycin have been developed, but use should be judicious and aided by input from an infectious disease specialist to avoid development of widespread resistance. In all cases, there should be a high degree of suspicion for line and access infections, and a low threshold for removal of central venous catheters.
4. **Valve replacement.** ESKD is not a contraindication to valve surgery. Indications for surgery are the same as in the general population: progressive valvular destruction, progressive heart failure, recurrent embolization, and failure to respond to appropriate antibiotic therapy. Based on USRDS data, in-hospital mortality following aortic or mitral valve replacement for bacterial endocarditis is approximately 14%, and 6-month survival is approximately 60% and does not differ between tissue and prosthetic valves (Leither, 2013). Whether a role exists for transcatheter aortic valve replacement in the setting of endocarditis remains unknown, and the literature is currently limited to case reports in the general population.

VII. VALVULAR CALCIFICATION AND STENOSIS

- A. **Mitral annular calcification.** Mitral annular calcification may occur in as many as 50% of patients on dialysis and is also common in the elderly general population. It is recognized on echocardiography as a uniform echodense rigid band located near the base of the posterior mitral leaflet, and may progressively involve the posterior leaflet. Complications

include conduction abnormalities, embolic phenomena, mitral valve disease, and increased risk of endocarditis. There are no proven preventive or treatment strategies.

B. Aortic calcification and stenosis. Aortic valve calcification occurs in 25%–55% of dialysis patients. Risk factors are similar to those for other forms of vascular calcification. Calcification may result in progressive immobilization of the aortic leaflets, eventually restricting flow. Functional aortic stenosis exists when the valve leaflets thicken to the extent that a pressure gradient develops across the aortic valve.

1. **Symptoms and signs.** Angina, congestive heart failure, and syncope are the cardinal symptoms of critical aortic stenosis. Frequent episodes of intradialytic hypotension may be a clue as the heart has difficulty in adapting to conditions of reduced filling. The classical systolic murmur that radiates to the carotid arteries may be present; this typically begins after S1 and ceases prior to S2; additionally, S2 may be fixed or paradoxically split. However, it is often difficult to differentiate the murmur of aortic stenosis from that heard in aortic sclerosis or from benign flow murmurs.

2. **Diagnosis** is by echocardiography and cardiac catheterization, and mirrors diagnostic methods in the nondialysis population.

3. **Valve replacement** is the therapy of choice. Timing depends on perceived risks versus anticipated benefits. Studies from the USRDS have not demonstrated any difference in survival based on the use of tissue versus nontissue bioprosthetic valves. The mortality rate for valve replacement (with or without concurrent coronary artery bypass surgery) is relatively high for dialysis patients; however, in most cases, the prognosis is worse if clinically indicated surgery is not performed or if emergent surgery rather than elective surgery is performed. To date, several small case series have reported successful transcatheter aortic valve implantation procedures in dialysis patients, although dialysis patients have been excluded from clinical trials assessing this less invasive procedure.

VIII. VENTRICULAR ARRHYTHMIAS, CARDIAC ARREST, AND SUDDEN CARDIAC DEATH

A. Risk factors. Many comorbid conditions that are highly prevalent in dialysis patients are also associated with arrhythmias. These include LVH, chamber enlargement, valve abnormalities, and ischemic heart disease. Additionally, serum levels of cations that can affect cardiac conduction, including potassium, calcium, hydrogen, and magnesium, are often abnormal and undergo rapid fluctuation during hemodialysis.

B. Cardiac arrest and acute arrhythmias. Sudden cardiac death is common among dialysis patients, with rates of 49 per 1,000 patient years in the hemodialysis population and 36 per 1,000 patient years among PD patients. According to the 2013 USRDS, cardiac arrest and arrhythmia account for ~25% of all deaths in dialysis patients. Thirty-day survival after cardiac arrest is only 32% and 1-year survival 15%. Potential strategies to reduce the risk of fatal cardiac risk include careful attention to fluid and electrolyte shifts. The risk of arrhythmias and cardiac arrest are increased in patients being dialyzed using a dialysate potassium level of less than 3 mEq/L (3 mM), and are most notable at lower potassium dialysate concentrations; it is the opinion of many nephrologists that low potassium dialysate (<2 meq/L [<2 mM]) should be avoided if possible. One recent study also

suggested an increased risk of sudden death associated with use of a low dialysis solution calcium concentration, particularly in individuals with higher serum calcium levels. Finally, multiple studies demonstrate a higher risk of sudden death following the long interdialytic interval among patients treated with thrice-weekly hemodialysis, further suggesting that electrolyte or volume abnormalities may be complicit.

For acute arrhythmias that occur during dialysis, the dialysis session should be terminated and blood returned cautiously. Urgent cardioversion per advanced cardiac life support (ACLS) guidelines is indicated for all patients with an unstable rhythm, and all dialysis facilities should have automated external defibrillators available and staff trained in their use. Amiodarone, currently the first-line pharmacologic intervention for ventricular tachycardia in the general population, is dosed identically in dialysis patients. Airway management and cardiac monitoring is essential. Administration of procainamide and other class Ia antiarrhythmics should be undertaken with caution as they may cause QT prolongation and torsades de pointes in dialysis patients.

Adequate data on the benefits of implantable cardioverter defibrillators (ICD) are lacking in dialysis patients. While, intuitively, given the high risk of ventricular arrhythmia, ICD use appears sensible, ICDs are associated with an increased risk of infection and central vein stenosis (Hickson, 2014).

C. Chronic arrhythmias

1. **Atrial fibrillation** remains the most common arrhythmia in both the general and dialysis population, and often occurs in patients with structural heart disease and, in particular, left atrial enlargement. Prevalence estimates for paroxysmal and permanent atrial fibrillation are as high as 30% in individuals with advanced CKD, including dialysis patients.

a. **Drug therapy.** The benefits of rhythm versus rate control remain uncertain at this time. Several medications have traditionally been used for rate control in atrial fibrillation, including digoxin, β -blockers, nondihydropyridine calcium channel blockers and amiodarone. β -Blockers or nondihydropyridine calcium channel blockers such as diltiazem are good choices for rate control in patients with intact systolic function, but may be contraindicated in subjects with reduced cardiac function due to their negative inotropic effects. In these subjects, there clearly is a trade-off, as chronic control of tachycardia may offset any drug-related decrease in cardiac inotropy. Although a less effective agent for rate control, digoxin is frequently used in patients with reduced systolic function. Paradoxically, digoxin use is also associated with a high risk of arrhythmias. When digoxin is used in dialysis patients, extreme care must be taken to minimize electrolyte shifts and, in particular, hypokalemia. These patients should generally be on a 3 mEq/L potassium bath. Less alkaline dialysate may also be necessary to prevent potassium shifts. Amiodarone may be the drug of choice when rate control is not adequate with β -blockers or calcium channel blockers. Importantly, owing to drug interactions among warfarin, amiodarone, and digoxin, combinations of these drugs should be used with caution.

b. **Anticoagulation.** The risks and benefits of warfarin therapy should be considered on

an individual basis in all dialysis patients with chronic and paroxysmal atrial fibrillation. There are no consistent data regarding anticoagulation for atrial fibrillation in the dialysis population. Recently, warfarin use has been linked to calciphylaxis in dialysis patients (warfarin skin necrosis and calciphylaxis have similar pathologic appearance). Warfarin is also associated with an increased risk of vascular calcification. The 2014 AHA/ACC/HRS Guideline for the Management of Patients with Atrial Fibrillation states that it's reasonable to prescribe warfarin to hemodialysis patients with nonvalvular atrial fibrillation with a CHA2DS2-VASc score of 2 or greater; implicit in the strength of the recommendation is that additional studies are needed to support this statement (January, 2014). These same guidelines are silent regarding warfarin use in PD patients.

2. **Ventricular arrhythmias and ectopy** are common in the dialysis population. There are no data indicating that cardiac management of patients prone to arrhythmia should be any different than in the general population. When indicated, dialysis patients may benefit from implantable defibrillators, although the cost–benefit of these devices remains uncertain given their unproven benefit in this population and potential risks as described above. Amiodarone therapy is generally well tolerated in dialysis patients, and dosing is identical to that in the general population.

IX. STROKE. Cerebrovascular disease is also very common in individuals with CKD, with high incidence of both ischemic and hemorrhagic events. Even in the absence of clinically evident strokes, silent lesions and substantial brain white matter disease may be present. The presence of cardiovascular disease is associated with cerebrovascular manifestations in individuals with CKD, including worse cognitive function. As discussed above, given the frequency with which atrial fibrillation occurs in individuals with kidney failure, the use of warfarin and other anticoagulants for stroke prophylaxis in the dialysis population urgently requires an adequately powered clinical trial to inform optimal treatment decisions.

References and Suggested Readings

Agarwal R, et al. Hypertension in hemodialysis patients treated with atenolol or lisinopril: a randomized controlled trial. *Nephrol Dial Transplant*. 2014;29:672–681.

Charytan DM. How is the heart best protected in chronic dialysis patients?: between scylla and charybdis: what is the appropriate role for percutaneous coronary revascularization and coronary artery bypass grafting in patients on dialysis? *Semin Dial*. 2014;27:325–328.

Cice G, et al. Carvedilol increases two-year survival in dialysis patients with dilated cardiomyopathy: a prospective, placebo-controlled trial. *J Am Coll Cardiol*. 2003;41:1438–1444.

Cice G, et al. Effects of telmisartan added to angiotensin-converting enzyme inhibitors on mortality and morbidity in hemodialysis patients with chronic heart failure a double-blind, placebo-controlled trial. *J Am Coll Cardiol*. 2010;56:1701–1708.

deFilippi C, et al. Cardiac troponin T and C-reactive protein for predicting prognosis, coronary atherosclerosis, and cardiomyopathy in patients undergoing long-term hemodialysis. *JAMA*. 2003;290:353–359.

- Goldfarb-Rumyantzev AS, et al. The association of lipid-modifying medications with mortality in patients on long-term peritoneal dialysis. *Am J Kidney Dis.* 2007;50:791–802.
- Herzog CA, et al. Clinical characteristics of dialysis patients with acute myocardial infarction in the United States: a collaborative project of the United States Renal Data System and the National Registry of Myocardial Infarction. *Circulation.* 2007;116:1465–1472.
- Hickson LJ, et al. Clinical presentation and outcomes of cardiovascular implantable electronic device infections in hemodialysis patients. *Am J Kidney Dis.* 2014;64:104–110.
- Inrig JK. Antihypertensive agents in hemodialysis patients: a current perspective. *Semin Dial.* 2010;23:290–297.
- Iseki K, et al.; Olmesartan Clinical Trial in Okinawan Patients Under OKIDS (OCTOPUS) Group. Effects of angiotensin receptor blockade (ARB) on mortality and cardiovascular outcomes in patients with long-term haemodialysis: a randomized controlled trial. *Nephrol Dial Transplant.* 2013;28:1579–1589.
- January CT, et al. 2014 AHA/ACC/HRS Guideline for the Management of Patients With Atrial Fibrillation: Executive Summary: A Report of the American College of Cardiology/American Heart Association Task Force on Practice Guidelines and the Heart Rhythm Society. *Circulation.* 2014, in press.
- Kidney Disease: Improving Global Outcomes (KDIGO) Lipid Work Group. KDIGO Clinical Practice Guideline for Lipid Management in Chronic Kidney Disease. *Kidney Int.* 2013;(suppl 3):259–305.
- K/DOQI. K/DOQI clinical practice guidelines for cardiovascular disease in dialysis patients. *Am J Kidney Dis.* 2005;45(suppl 3):S1–S153.
- Kilpatrick RD, et al. Association between serum lipids and survival in hemodialysis patients and impact of race. *J Am Soc Nephrol.* 2007;18:293–303.
- Lau WL, Ix JH. Clinical detection, risk factors, and cardiovascular consequences of medial arterial calcification: a pattern of vascular injury associated with aberrant mineral metabolism. *Semin Nephrol.* 2013;33:93–105.
- Leither MD, et al. Long-term survival of dialysis patients with bacterial endocarditis undergoing valvular replacement surgery in the United States. *Circulation.* 2013;128:344–351.
- Matsumoto Y, et al. Spironolactone reduces cardiovascular and cerebrovascular morbidity and mortality in hemodialysis patients. *J Am Coll Cardiol.* 2014;63:528–36.
- Miller M, et al. American Heart Association Clinical lipidology, thrombosis, and prevention committee of the council on nutrition, physical activity, and metabolism; council on arteriosclerosis, thrombosis and vascular biology; council on cardiovascular nursing; council on the kidney in cardiovascular disease. Triglycerides and cardiovascular disease: a scientific statement from the American Heart Association. *Circulation.* 2011;123:2292–333.
- Ricks J, et al. Glycemic control and cardiovascular mortality in hemodialysis patients with diabetes: a 6-year cohort study. *Diabetes.* 2012;61:708–715.
- Selby NM, et al. Dialysis-induced regional left ventricular dysfunction is ameliorated by cooling the dialysate. *Clin J Am Soc Nephrol.* 2006;1:1216–225.
- Thygesen K, et al. Joint ESC/ACCF/AHA/WHF task force for Universal definition of myocardial infarction. Third universal definition of myocardial infarction. *J Am Coll Cardiol.* 2012;60:1581–1598.

Zannad F, et al. Prevention of cardiovascular events in end-stage renal disease: results of a randomized trial of foscinopril and implications for future studies. *Kidney Int.* 2006;70:1318–1324.

In women with end stage kidney disease, fertility is decreased but the possibility of pregnancy is high enough that it needs to be prevented if not desired and managed carefully by a multidisciplinary team if it does occur. The hypothalamic–pituitary–ovarian axis is deranged, contributing to decreased fertility, loss of libido, and abnormal uterine bleeding.

I. BIRTH CONTROL

- A. **Indications.** Forty percent of women under the age of 55 treated with dialysis menstruate, but periods may be anovulatory or characterized by a shortened luteal phase (Holley, 1997). Infertility is the rule, with pregnancy occurring in 0.3% to 1% per year in women aged 14–44. There is some suggestion that the use of erythropoietin and the increasing intensity of dialysis resulting from increased target Kt/V may have changed the hormonal abnormalities and other factors contributing to infertility in dialysis patients and that the frequency of pregnancy may have increased. A role for increased dialysis in increasing fertility is suggested by the experience of the nocturnal dialysis program at the University of Toronto, where, on average, women are receiving 36 hours of dialysis per week (Nadeau-Fredette, 2013). In this program, conception has occurred in 15% of women of childbearing age. Dialysis patients on standard dialysis regimens occasionally conceive, and when pregnancies occur, patient management is enormously complicated. Birth control is advisable for women who do not wish to conceive. It is difficult to identify women at high risk for pregnancy. Women who become pregnant once on dialysis frequently conceive again. Women who have become pregnant with renal insufficiency prior to starting dialysis, and women with regular menses are at increased risk, but pregnancies have occurred in women treated with dialysis following years of amenorrhea.
- B. **Methods of contraception.** Diaphragms and condoms can be used as in individuals with normal renal function. The incidence of pregnancy with barrier methods is as high as 25%–29% per year in normal women, but would be expected to be much lower in dialysis patients. Many women may opt for more effective and less cumbersome methods of contraception. Oral contraceptives can be used but are contraindicated in women with a history of thrombophlebitis or severe hypertension. Low-dose estrogen oral contraceptives can be used in patients with lupus who have no history of thrombosis or uncontrolled hypertension. Copper and levonorgestrel containing IUDs (intrauterine devices) can be used in women with diabetes, diabetes with nephropathy, systemic lupus erythematosus,

and multiple cardiovascular risk factors, and are good birth control methods for women both on hemodialysis (HD) and peritoneal dialysis (PD). There are no guidelines from the U.S. Medical Eligibility Criteria for Contraceptive Use or from randomized controlled trials. There has been some concern that IUDs might increase the risk of peritonitis in women on PD, but this risk has not been well studied. There has also been concern without information on the effect of estrogen on access patency. The provision of estrogen offers the theoretical benefit of protecting bones from the effects of hypoenestrogenemia seen in dialysis patients.

Many women on dialysis have prolonged periods of anovulatory bleeding, associated with the unopposed effect of estrogen on the endometrium. Estrogen–progesterone cycling might reduce the risk of endometrial cancer that is associated with unopposed estrogen. Treatment of infertility has generally not been attempted because pregnancy is dangerous for the mother and the outcome is still poor. The exception is a switch to nocturnal dialysis with higher rates of conception.

II. PREGNANCY

- A. **Frequency and outcome.** Estimates of the frequency of pregnancy in women of childbearing age treated with dialysis range from a high of 1.4% per year in Saudi Arabia to 0.44% in Japan to a low of 0.3% per year in Belgium (Nadeau-Fredette, 2013). The frequency of pregnancy in American women on dialysis is about 0.5% per year (Okundaye, 1998). For reasons that are unclear, conception occurs two to three times more frequently in hemodialysis patients than in PD patients. The likelihood of pregnancy in a dialysis patient resulting in a surviving infant, excluding elective abortions, is about 50%. The chances of success improve once she has reached the second trimester, and then it approaches 60%–70%. There is a further improvement in outcome with intensive dialysis. For women who start dialysis after conception, the likelihood of having a surviving infant is 75%–80%. Of unsuccessful pregnancies, 68% result in spontaneous abortion, 13% in stillbirth, 16% in neonatal death and 3% in therapeutic abortion for life-threatening maternal problems. Approximately 40% of spontaneous abortions occur in the second trimester.
- B. **Diagnosis.** A high index of suspicion is required to make a timely diagnosis of pregnancy. Amenorrhea is common, and symptoms of early pregnancy such as nausea are often attributed to metabolic or gastrointestinal problems. A blood-based pregnancy test (serum levels of the β subunit of HCG) should be done prior to radiographic studies for abdominal complaints. Urine pregnancy tests are not reliable even if the patient is not anuric. Even with blood tests, false positives and false negatives occur. The small amounts of HCG produced by somatic cells may be excreted slowly enough in renal failure for blood levels to be borderline positive for pregnancy. Occasionally, these borderline results have led to cancellation of elective surgery. During pregnancy, β -HCG levels are more elevated than expected for gestational age, so gestational age is best assessed by ultrasound. Failure to appreciate the high β -HCG levels has led to mistaken diagnosis of a hydatidiform mole and the mistaken belief that a pregnancy was not viable when no fetal heart beat was found when high levels of β -HCG led doctors to think the pregnancy was more advanced than it was (Potluri, 2011). The reasons for false negative tests are unclear. Similarly, serum tests

of α -fetoprotein done to screen for Down's syndrome may be falsely elevated in pregnant dialysis patients, and amniocentesis with karyotyping should be done to confirm abnormal results.

- C. **Management of hypertension during pregnancy.** The major maternal risk associated with pregnancy in dialysis patients is severe hypertension. Eighty percent of pregnant dialysis patients have some degree of hypertension (BP >140/90 mm Hg). Forty percent have severe hypertension with diastolic blood pressures greater than 110 mm Hg or systolic blood pressures greater than 180 mm Hg. Seventy-five percent of severe hypertension occurs before the third trimester. Intensive care unit admissions for control of accelerated hypertension are required in 2% to 5% of pregnant dialysis patients. Patients should be taught to take their blood pressure on nondialysis days and report any increases in blood pressure promptly. Monitoring of blood pressure should continue for 6 weeks postpartum. Hypertension, even when severe, may not require the termination of pregnancy. The first step toward blood pressure control as in the nonpregnant patient is to make sure that the woman is euvolemic.
1. **Drug therapy.** If the blood pressure remains higher than 140/90 mm Hg when the patient is euvolemic, there are several first line drugs that can be used safely, including α -methyldopa, labetalol, and calcium channel blockers. There is less experience with β -blockers and clonidine, but, with the exception of atenolol, these are probably safe. Hydralazine can be added to any of these first line drugs, but it does not work as a single agent when given orally. Angiotensin converting enzyme inhibitors and angiotensin receptor blockers are contraindicated in pregnancy. In animal studies, they have been associated with a fetal loss rate of 80%–93%. In humans, their use has been associated with an ossification defect in the skull, dysplastic kidneys, neonatal anuria, and death from hypoplastic lungs. One report that noted an increase in congenital anomalies with first trimester exposure to ACE inhibitors has driven practice away from first trimester use (Cooper, 2006) despite contradictory data in other studies.
 2. **Superimposed preeclampsia and hypertensive crisis.** Women treated with chronic dialysis are at increased risk for superimposed preeclampsia, but the diagnosis is difficult to make in the absence of findings of the HELLP (**H**emolysis, **E**levated **L**iver **E**nzymes, **L**ow **P**latelets) syndrome such as thrombocytopenia, elevated liver enzymes, or microangiopathic hemolytic anemia.

There appears to be some benefit of low-dose aspirin in preventing preeclampsia in women at high risk for the disease. Although dialysis patients have not been specifically studied, they constitute an extremely high-risk group and can be given 75 mg daily of aspirin.

- a. **Antihypertensive drugs.** Intravenous hydralazine is the drug of first choice for hypertensive crisis in pregnant women and should be given in doses of 5–10 mg every 20–30 minutes. Labetalol is a good alternative. It can be given as a 20-mg bolus repeated every 30 minutes to a maximum of 220 mg or as a continuous infusion with 1 to 2 mg/min followed by 5–10 mg/hr to a maximum of 300 mg.
- b. **Magnesium.** Magnesium is superior to other anticonvulsants for seizure prophylaxis in women with preeclampsia, but it must be used with extreme caution in dialysis patients. A loading dose can be given safely. Additional magnesium should not be

given until after dialysis or until after a drop in the serum magnesium level has been demonstrated. Magnesium potentiates the hypotensive effects of calcium channel blockers, and any calcium channel blocker should be stopped if magnesium is required.

D. Dialysis regimen during pregnancy

1. **Dialysis modality.** In direct comparisons of dialysis modalities, there is no difference in outcome of pregnancy between hemodialysis patients and peritoneal dialysis patients, as measured by either infant survival or mean gestational age of live-born infants (Okundaye, 1998). However, it is easier to increase the amount of dialysis delivered with hemodialysis. The higher success rates reported in more recent studies have been achieved in hemodialysis patients. Although dialysis modality should not be changed because of pregnancy, it may be easier to start hemodialysis in a pregnant woman than peritoneal. If peritoneal dialysis is elected, placement of a peritoneal catheter is possible at any stage of pregnancy, but immediate use and increased intra-abdominal pressure may increase the risk of leaking around the catheter. There have been instances of mechanical problems with peritoneal catheters with changes in fetal position. Some nephrologists have elected to supplement peritoneal dialysis with hemodialysis when pregnancy is near term.
2. **Intensive dialysis.** There is growing evidence that the likelihood of a surviving infant is increased with intensive dialysis. The ideal number of hours of dialysis has not been established. There was a marked improvement in outcomes for women dialyzed more than 20 hours per week, with a corresponding decrease in severe prematurity compared with less intense regimens (Hou, 2010). Infant survival was 75% for pregnancies in the group dialyzed more than 20 hours a week compared with 33% and 44% for less intensively dialyzed groups. Mean gestational age for babies born to women dialyzed more than 20 hours a week was 34 weeks compared with 30 weeks in less intensively dialyzed women. Even better outcomes have been seen in women undergoing nocturnal hemodialysis 48 hours weekly with most infants surviving and born close to term (Nadeau-Fredette, 2013). In a comparison of pregnancy results in the United States versus Canada, there was a suggestion of a “dose response” relationship between duration of weekly dialysis and pregnancy outcomes (Hladunewich, 2014). There may be some amount of dialysis between 20 and 48 hours a week that will lead to satisfactory outcomes. Daily dialysis decreases the fluid removal at each treatment, decreasing the risk of hypotension during dialysis. Daily dialysis also allows the patient to eat a high-protein diet to ensure that the needs of pregnancy are met.

Increasing the intensity of dialysis in peritoneal dialysis patients is difficult. Late in pregnancy, women have difficulty with severe abdominal distension, and exchange volume may have to be decreased. It becomes necessary to increase the frequency of exchanges even to maintain the same level of dialysis. A combination of frequent daytime exchanges and nighttime cycler is often necessary.

Some have raised the question whether increased dialysis might have a detrimental effect by causing electrolyte abnormalities or by removing progesterone. Progesterone withdrawal plays a role in the initiation of labor. Measurements of serum

progesterone levels during dialysis in pregnant dialysis patients are variable. Brost and colleagues (1999) measured pre- and postdialysis progesterone levels in seven pregnant dialysis patients. Changes in serum progesterone ranged from a 52% decrease in levels to an 8% increase (Brost, 1999). Changes in serum progesterone were not associated with changes in home uterine activity monitoring.

3. **Dialysis solution calcium.** With the recognition of the risk of soft tissue calcification in long-term dialysis patients, a 2.25 mEq/L (1.125 mM) or 2.5 mEq/L (1.25 mM) calcium concentration has replaced 3.5 mEq/L (1.75 mM) as standard. When a bath containing 2.5 mEq/L (1.25 mM) is used, the patient is usually in positive calcium balance, averaging about 200 mg/treatment. There is some production of calcitriol by the placenta that may increase serum calcium. Predialysis serum calcium levels should be checked weekly. The fetus needs 25 to 30 g of calcium for calcification of the fetal skeleton. With a 2.5 mEq/L (1.25 mM) bath, 25 weeks of dialysis should provide enough calcium, but premature birth is common enough, and calcium flux variable enough, that oral supplementation is advisable. If the woman requires phosphate binders, 1 to 2 g of elemental calcium should be sufficient. Over the long term, dialysate calcium should be low enough to minimize soft tissue calcification, but over the short term of pregnancy, calcium should be sufficient for the fetal skeleton. Skeletal abnormalities have been described in one baby born to a dialysis patient. For women who need phosphate binders, calcium-containing binders are the only group known to be safe in pregnancy. There is no experience with sevelamer or lanthanum carbonate in pregnancy. Lanthanum is neurotoxic in fetal mice.

Some women become hypophosphatemic. Often, phosphate binders are no longer required, and it may be necessary to add phosphorus to the bath (e.g., 4 mg/dL [1.3 mM] phosphorus or higher). For women who do not need phosphate binders, calcium can be provided in a lower dose separate from meals. Experience with cinacalcet in pregnancy is limited to a few case reports of use in primary hyperparathyroidism. Serum calcium and phosphorus should be monitored weekly. Hypercalcemia may suppress the fetal parathyroid glands and cause neonatal tetany.

4. **Dialysis solution bicarbonate.** With a standard bath, daily dialysis carries a theoretical risk of alkalosis. Metabolic alkalosis carries an increased risk in pregnant women who have a concurrent respiratory alkalosis; however, in the few instances where arterial blood gases have been done, compensatory hypercapnia has occurred in women with severe metabolic alkalosis. Serum bicarbonate in normal pregnancy is 18–20 mmol/L. A 25 mM bicarbonate dialysis bath is usually effective in avoiding alkalosis. When this bicarbonate concentration is not available, bicarbonate can be removed by increasing ultrafiltration and replacing the losses with saline.
5. **Dialysis solution sodium.** Normal serum sodium is decreased during pregnancy to approximately 134 mmol/L. Since thirst is normal, the pregnant woman will take in enough water to normalize serum sodium if it is high at the end of dialysis. With daily dialysis, fluid removal should be modest enough to make sodium modeling unnecessary.
6. **Monitoring weight gain.** Determination of optimal postdialysis weight is problematic in

pregnant dialysis patients. Recommended weight gain for women who become pregnant at their ideal body weight is 11.5–16 kg. Only 1.6 kg of this weight gain occurs in the first trimester. During pregnancy, there is a 50% increase in blood volume, but vasodilatation normally prevents the development of hypertension. There is some evidence that blood volume does not increase appropriately in pregnant women with renal insufficiency, but blood volume has not been studied in pregnant dialysis patients.

In early pregnancy, it may become difficult to dialyze the patient down to her prepregnancy dry weight, but the change should be only 0.9 to 2.3 kg, depending on the prepregnancy body mass index (BMI). Recommended weight gain in the second and third trimesters is between 0.3 and 0.5 kg per week, again depending on the prepregnancy BMI. While the nutritionist in the dialysis unit can provide dietary guidelines for appropriate weight gain during pregnancy, the most pressing question for the dialysis unit staff is determining how much of the weight change between treatments is excess fluid and how much is part of the desired pregnancy-associated weight gain.

With daily dialysis, fluid gain between treatments should be small, but the majority of the day-to-day change in weight is still usually fluid. The woman should have a careful weekly examination to look for signs of fluid overload. With daily dialysis, volume-related hypertension should be minimized, and if there is any increase in blood pressure, particularly during dialysis, the patient should be evaluated for preeclampsia.

7. **Heparinization.** Clotting of the extracorporeal circuit or the dialysis access occurs frequently during pregnancy. Heparin does not cross the placenta, and unless there is vaginal bleeding, it is not necessary to lower the dose.
- E. **Management of anemia.** Anemia in pregnant women is associated with premature birth and low birth weight. The hemoglobin level at which anemia contributes to these problems is not well established. Dialysis patients who become pregnant usually experience worsening anemia. Plasma volume increases while red cell mass, which increases in normal pregnancy, is limited by erythropoietin dose. While target hemoglobin levels for nonpregnant dialysis patients have decreased, a target for pregnancy has not been clearly established. However, we would choose a target of 10–11 g/dL (100–110 g/L) until more data are available, based on the World Health Organization's definition of anemia in pregnancy as a hemoglobin of 11 g/dL (110 g/L) or less.
1. **Erythropoiesis stimulating agents (ESA).** It has become usual practice to continue erythropoietin during pregnancy. Prior to the availability of erythropoietin, transfusion was usually needed in any pregnancy that progressed beyond the first trimester. All ESAs available are listed by the USA as being in “category C” in pregnancy (FDA pregnancy drug risk categories are A, B, C, D, and X, with X being the highest risk). Congenital anomalies have not been reported in the infants of the small number of women who took erythropoietin during organogenesis. In animals, congenital anomalies have been seen, but only at doses of 500 units/kg. Recombinant erythropoietin does not cross the placenta, but it is not known whether darbepoetin crosses the placenta. There are a few case reports of the use of darbepoetin in pregnancy without problems. Erythropoietin has been associated with hypertension in nonpregnant patients, but it is

difficult to determine what factors influence hypertension during pregnancy. Women treated with erythropoietin prior to pregnancy require increased doses during pregnancy. The hematocrit has usually dropped by the time the pregnancy is recognized. We recommend increasing the dose of erythropoietin by 25% until the target hemoglobin is reached.

2. **Iron therapy.** While the effects of pharmacologic doses of erythropoietin stimulating agents on the fetus are unknown, there is a little known downside to treating iron deficiency. Pregnancy in normal women requires 700–1150 mg of iron. Daily hemodialysis increases iron losses over the usual amounts. We have found an increase in iron requirements during pregnancy and have given intravenous iron, but because of the high rate of transfer to the fetus, especially after 30 weeks' gestation, we limit individual doses to 62.5 mg. The FDA has labeled ferric gluconate and iron sucrose category B risk for pregnancy.
3. **Folate.** Folate requirements are increased in normal pregnant women. Folate deficiency is associated with an increase in neural tube defects. Folate losses increase with intensive dialysis, and folate supplementation should be quadrupled.

III. **LABOR AND DELIVERY.** Eighty percent of infants born to dialysis patients are premature. Reasons for prematurity include premature labor, maternal hypertension, and fetal distress, with premature labor being the most common.

Efforts to prevent premature labor include serial measurements of cervical length and in some cases cerclage. Progesterone has been used in other settings to prevent premature labor, and although it has not been used in dialysis patients, their risk of premature labor is so high that they should be considered candidates for its use.

Premature labor in dialysis patients has been successfully treated with terbutaline, magnesium, nifedipine, and indomethacin. Magnesium has been given intravenously in hemodialysis patients and has been added to the peritoneal dialysis solution in peritoneal dialysis patients. Magnesium must be used with extreme care in women with renal failure. Blood levels should be monitored frequently. A loading dose can be given, but additional doses should be given only after dialysis and when the level is low. The use of magnesium in combination with nifedipine should be avoided because the combination can cause profound hypotension. Indomethacin has also been used with success, but patients must be monitored for oligohydramnios, and the fetus must be monitored for right heart dilatation. Indomethacin can be used only for a short time. While all tocolytics (a tocolytic is an anticontraction medication used to repress labor) are used for a short time, premature labor frequently recurs, and repeated use of indomethacin is problematic. In women with residual kidney function, indomethacin use may result in further deterioration in glomerular filtration rate and the need for increased dialysis.

Infants of dialysis patients are frequently small for gestational age, but it is not clear whether their growth restriction is the result of uremic toxins *per se* or of maternal hypertension. Decreased intrauterine growth restriction in nocturnal dialysis patients suggests a role for accumulated uremic toxins. There is an increased risk of stillbirth in dialysis patients, and antenatal monitoring should be started as soon as there is a chance of survival outside the mother (26 weeks).

In PD patients, caesarian section can be done extraperitoneally, leaving the catheter in place, and PD can be resumed 24 hours after delivery, starting with small exchange volumes and increasing over a 48-hour period. If there is leakage from the incision, the patient can be hemodialyzed for 2–4 weeks.

Even a normal appearing infant should be monitored in a high-risk nursery. At birth, the infant, whose kidneys are normal for gestational age, will have a blood urea nitrogen (BUN) and serum creatinine levels similar to the mother's, and the infant will experience a solute diuresis, requiring careful monitoring of electrolytes and volume status.

There does not appear to be any increased risk of congenital anomalies, but information on growth and development is sketchy.

IV. DYSpareunia. Some women dialysis patients may experience dyspareunia because of estrogen deficiency and resulting vaginal dryness. Postmenopausal women experiencing these symptoms can be prescribed either a conjugated estrogen cream, a sustained-release intravaginal estrogen ring or a vaginal low-dose estrogen tablet. Typical doses for local estrogen are one estradiol tablet, 10 mcg, inserted intravaginally once a day for 7 days, and then two or three times a week. A vaginal ring containing 2 mg of estradiol can be inserted and then replaced every 3 months. Conjugated estrogen cream can be used; the usual dose is 0.5 g per day for 21 days on, then 7 days off. An alternative regimen is to apply the cream twice weekly. Estrogen cream has been associated with more side effects, for example, breast tenderness, vaginal bleeding, and perineal pain. The North American Menopause Society does not recommend use of progestogen in women treated with local estrogen therapies. Oral estrogen is rarely necessary in dialysis patients, and when needed, a daily dose of 0.3 mg of conjugated estrogen and 2.5 mg of medroxyprogesterone provides enough estrogen to prevent dyspareunia since estrogen is metabolized more slowly in dialysis patients. If there is breakthrough bleeding on this combination, progesterone can be increased to 5 mg.

V. SEXUAL DYSFUNCTION

A. Incidence and etiology. Fifty percent of female dialysis patients under the age of 55 are sexually active. A majority of women on dialysis experience some sexual dysfunction. They suffer both decreased libido and decreased ability to achieve orgasm. Treatment with erythropoietin appears to be associated with an improvement in sexual function, but most of the data collected have been in men. Various reasons for sexual dysfunction have been proposed, including hyperprolactinemia, gonadal dysfunction, depression, hyperparathyroidism, and change in body image.

B. Hyperprolactinemia. Studies from 30 years ago reported hyperprolactinemia in 75%–90% of female dialysis patients. The mean serum prolactin levels in women with sexual dysfunction are higher than in patients with normal sexual function. While prolactin levels have not been formally reevaluated, informal observation suggests that the frequency of hyperprolactinemia has decreased. Treatment of hyperprolactinemia with the dopamine agonist bromocriptine has been reported (in limited uncontrolled studies) to improve sexual function in both men and women on dialysis. It has not come into widespread use because hemodialysis patients may be particularly susceptible to the hypotensive effects of

this drug. When correctable physical problems cannot be found, dialysis patients should be referred for sex therapy, as would patients without renal failure.

VI. ABNORMAL UTERINE BLEEDING. In 2011, the International Federation of Gynecology and Obstetrics (FIGO) developed new terminology for what was previously called “Dysfunctional Uterine Bleeding,” and the term Abnormal Uterine Bleeding is now preferred.

A. Incidence Many women develop amenorrhea when the glomerular filtration rate falls to less than 10 mL/min. Menstruation returns in as many as 60% once dialysis is started. Regular menstruation has become more common in premenopausal women with end stage kidney disease (ESKD) than it was in the early days of dialysis; however, over half of women with ESKD who menstruate report hypermenorrhea. Women on HD and those on PD report similar menstrual abnormalities. Approximately 60% of those who menstruate have irregular cycles. Abnormal uterine bleeding is common and is of concern because it may be an early sign of endometrial cancer. Blood loss may lead to severe anemia even in women treated with erythropoietin, although the introduction of erythropoietin has made the management of abnormal uterine bleeding substantially easier.

B. Management

1. **Screening for malignancy.** Management depends on age and therefore risk for carcinoma. There is some suggestion that women on hemodialysis may be more likely to have endometrial hyperplasia and carcinoma compared with women without renal disease, so a high index of suspicion is warranted.

a. **Women older than 40 years of age** who have abnormal uterine bleeding should have endometrial sampling. In general, endometrial biopsy done in the office has replaced dilatation & curettage, because there is excellent correlation between the histopathology of endometrial specimens taken by biopsy in the office and D&C (dilatation and curettage) performed in the operating room. If the endometrial biopsy is nondiagnostic, or bleeding persists after a negative biopsy, further diagnostic testing should be done.

b. **Women younger than 40 years.** The cancer risk is relatively small, and a yearly Papanicolaou smear is usually sufficient to screen for malignancy.

2. **Anticoagulation.** The lowest possible dosage of heparin should be used to perform hemodialysis when a woman is menstruating. Heparin-free techniques are described in Chapter 14.

3. **Bloody peritoneal fluid during peritoneal dialysis.** During menstruation or ovulation, the peritoneal fluid can become bloody (Lew, 2007). There is no specific management, except perhaps to avoid addition of heparin to the peritoneal dialysis solution. In some cases, frank hemoperitoneum may occur, requiring suppression of ovulation (Harnett, 1987). An aseptic peritonitis picture during menstruation or ovulation has also been reported (Poole, 1987). Bloody peritoneal fluid frequently occurs after gynecologic procedures.

4. **Management of anemia.** Anemia should be managed with erythropoietin, as in other dialysis patients. Heavy uterine bleeding will result in increased iron requirements, and additional intravenous iron may have to be given.

5. **Hormonal therapy.** Given the evidence that hormonal replacement therapy may increase the incidence of cardiovascular events, and the excess cardiovascular mortality among women with ESKD, the risks associated with hormone replacement therapy may outweigh the benefits (see discussion below.)
 - a. Intrauterine delivery of progesterone in the form of **levonorgestrel intrauterine system** (Mirena) is probably the safest therapy and first line treatment for patients on hemodialysis who are experiencing abnormal uterine bleeding. Once the intrauterine device has been implanted, scanty menstruation should develop within 3 months. Peritonitis has been reported after placement of IUDs in patients on PD, so these patients should receive prophylaxis prior to insertion of the IUD. (American College of Cardiology guidelines do not recommend antibiotic prophylaxis prior to IUD insertion to prevent endocarditis.) This system is highly effective and in the vast majority of cases will obviate the need for systemic hormonal therapy.
 - b. **Oral contraceptives** would be a second line treatment, but they should be avoided if blood pressure control or risk of thrombotic disease is a problem. The theoretical benefits of using estrogen progesterone combinations to prevent uterine cancer and osteoporosis have been discussed above.
 - c. **Medroxyprogesterone acetate (Depo-Provera).** Progesterone can be given either intramuscularly as Depo-Provera 100 mg once a week for 4 weeks or orally as 10 mg daily for the first 10 days of the menstrual cycle. This drug is best reserved for patients with chronic hypermenorrhea who do not respond to more conservative intrauterine or oral hormonal therapy. Because many patients on dialysis have a bleeding tendency, IM injections on a regular basis are undesirable. Moreover, the half-life of IM medroxyprogesterone acetate in dialysis patients is unpredictable. Progestins work best in the setting of anovulatory bleeding.
 - d. **Gonadotropin releasing hormone agonists.** These can be given as an intramuscular injection once a month (leuprolide acetate) or a daily intranasal dose. These drugs are extremely expensive and should be reserved for patients who continue to have excessive menstrual bleeding and who do not respond to intrauterine progesterone, oral contraceptives, or progestins. There is one report of ovarian hyperstimulation in a patient on chronic dialysis who received two doses of leuprolide acetate (Hampton, 1991).
 - e. **High-dosage intravenous estrogens.** In the case of acute excessive blood loss, high dose estrogen therapy can be used, giving 25 mg of conjugated estrogens IV every 6 hours. Bleeding usually subsides within 12 hours.
 - f. **Deamino arginine vasopressin (DDAVP).** In a setting of acute blood loss when bleeding time is prolonged, DDAVP should be given in a dosage of 0.3 µg/kg in 50 mL of saline every 4–8 hours for three to four doses.
6. **Nonsteroidal anti-inflammatory agents** have been shown to be effective in women who ovulate. These agents may be less effective in the setting of ESKD because of the increased incidence of anovulatory cycles in women with ESKD. Also, women with end stage kidney disease are at increased risk for gastrointestinal complications.

7. **Endometrial ablation.** Endometrial ablation can be performed by several surgical techniques: hysteroscopic endometrial ablation with laser, photocoagulation, roller ball, or loop resection. Patients are pretreated with either danazol or gonadotropin releasing hormone for 3–4 weeks before the procedure to thin the endometrium. The procedure leads to permanent infertility.
8. **Hysterectomy.** For postmenopausal women with significant dysfunctional uterine bleeding, hysterectomy may be the approach of choice. Laparoscopic hysterectomy is now an option and for leiomyomata too large for laparoscopic surgery, gonadotropin releasing hormones can be given to reduce the size of fibroids enough to make laparoscopic hysterectomy possible. The proposed operation should be carefully discussed with the patient, and concomitant medical problems and the risks of surgery should be taken into consideration. With the advent of endometrial ablation with laser, hysterectomy will now probably be reserved for women who have bleeding secondary to uterine fibroids or to other uterine or pelvic pathology that in itself warrants the surgery. Hysterectomy should be done only as a life-saving procedure in a premenopausal woman who is a candidate for renal transplantation because the latter will frequently restore fertility.

VII. HORMONE REPLACEMENT THERAPY. Women with end stage kidney disease treated with dialysis experience menopause on average 5 years earlier than women without renal failure. The role of hormone replacement therapy (HRT) in dialysis patients has never been clear. About 10% of postmenopausal women on dialysis take HRT. Most report that HRT was started before the initiation of dialysis. Of women not taking hormone replacement therapy, a majority say they would not take HRT if advised to do so by their doctors. Recent evidence of the risk of HRT raises concern about its use in ESKD patients. The Women's Health Initiative Study demonstrated an increased risk of breast cancer, pulmonary embolism, deep vein thrombophlebitis, and of coronary and cerebrovascular disease after long-term replacement of estrogen and progesterone in normal postmenopausal women. The only health advantage for women in the treatment group was in reduced fractures.

Women with ESKD have more than a 20-fold increased incidence of cardiovascular disease compared with women without ESKD while multifactorial bone disease is also more common and more severe in dialysis patients. The risk of hip fracture is higher in dialysis patients than in healthy people of the same age and sex. When young women on dialysis who have regular menses are compared with young women with amenorrhea, the group with amenorrhea has a significantly lower bone mineral density. Raloxifene 60 mg daily has been used successfully to prevent bone loss in postmenopausal estrogen-deficient dialysis patients, and this drug provides a safe alternative to HRT.

The use of HRT should be limited to the relief of symptoms of estrogen deficiency that cannot be relieved by other treatments. Only the patient can decide the importance of relieving these symptoms after understanding the risks. The increased risk of cardiovascular disease and breast cancer in healthy women taking HRT was small enough that many women have continued them. Unfortunately, the specific risk of HRT in hemodialysis patients has not been determined, and we can only extrapolate from the data in healthy women and women with preexisting heart

disease in advising patients of the risk.

It is still the general practice to treat women with premature ovarian failure or early surgical menopause with HRT. It may be difficult to know whether a woman is postmenopausal since even women with FSH and LH in the postmenopausal range may have normalization after transplant. A very small study (13 patients) found an improvement in sexual function and general well-being as well as an improvement in L2-L4 bone density in premenopausal dialysis patients taking HRT.

HRT is contraindicated in women with active liver disease and deep vein thrombophlebitis. Estrogen may make lupus flares more likely and may worsen hepatic cystic disease in women with polycystic kidney disease.

If HRT is prescribed, the dose should be adjusted in women on dialysis. Estrogen levels increase more in dialysis patients than in normal controls when estrogen is administered. If oral HRT is given to dialysis patients, the dose used should be about half of what would be given to a woman without renal failure. Transdermal estrogen may have less effect on clotting factors than oral estrogen.

VIII. GYNECOLOGIC NEOPLASMS

A. **Benign.** Uterine fibroids, or leiomyomata, are extremely common, occurring in as many as 80% of women over the age of 30, with approximately 25% of them being symptomatic. There is no information about their incidence in chronic renal failure. Uterine fibroids usually present with either menometrorrhagia or symptoms related to the enlarging uterus pressing on nearby organs, that is, pain, pressure, and constipation. Small, asymptomatic leiomyomata can be managed with observation. Indications for therapy include symptomatic bleeding, pain or pressure, urinary retention, torsion, degeneration with acute abdominal pain, prolapse through the cervix, and increase in the size after menopause. Women still in the childbearing age range who are potential candidates for transplant should have myomectomy performed rather than hysterectomy if that is surgically feasible, to preserve childbearing potential. Recently, a number of treatments other than hysterectomy have become available, including medical therapy with mifepristone (RU486, an abortifacient), gonadotropin releasing hormone agonists, laparoscopic myomectomy, myolysis, and uterine artery embolization. Laparoscopic myomectomy should not be done in women who plan childbearing because of the increased risk of uterine rupture when pregnancy occurs.

B. **Screening.** Women treated with dialysis are less likely to get regular mammograms and pap smears than women in the general population. The incidence of cervical cancer is increased in women with ESKD, while the incidence of breast cancer is similar to women without kidney disease. Several recent studies suggest that screening for malignancies in women with end stage kidney disease results in a negligible increase in life expectancy because of the shortened survival of women with end stage kidney disease. Such an outlook does not allow for the possibility that great strides will be made in the care of ESKD patients leading to prolonged survival. Young women, women awaiting transplantation, and women with increased risk for breast, ovarian, and cervical cancer should be screened. Women with the highest risk for cervical cancer include women who have been

treated with immunosuppressive therapy or who are currently on immunosuppressive therapy, either for previous transplant or for their underlying disease, or women with AIDS. These women should have pap smears performed every year.

C. **Evaluation of cancer in women who are symptomatic.** Endometrial cancer usually presents as abnormal uterine bleeding, the investigation and management of which was discussed above. Ovarian cancer usually presents with vague abdominal symptoms and later as an ovarian mass. Abdominal discomfort, nausea, and weight loss induced by ovarian cancer may initially be misinterpreted as symptoms of uremia or underdialysis. In patients on PD, ovarian cancer may present as bloody peritoneal fluid, an abnormal peritoneal cell count, or a change in the color of the fluid. A high index of suspicion is necessary to detect ovarian cancer at an early and potentially curable stage. The use of CA125 (cancer antigen 125) to screen for or follow ovarian cancer is of limited value in dialysis patients. It is not efficiently removed by dialysis and is also produced by mesothelial cells, giving rise to elevated levels, especially in PD patients.

D. **Diagnostic procedures**

1. **Lower gastrointestinal X-ray series.** When performing a lower gastrointestinal X-ray examination, the amount of water used to dilute the contrast material can be diluted to one-fourth the normal amount.
2. **Computed tomography.** Intravenous contrast infusion, if needed to perform a CT scan or angiography, is not contraindicated in dialysis patients. Although the administration of contrast involves increasing intravascular volume and osmolality, immediate dialysis following the study can be performed in the rare instance of symptoms. Dialysis can be done the following day if she is asymptomatic. A patient on peritoneal dialysis requiring an abdominal CT scan should present for the examination with dialysis fluid in the abdomen.
3. **Pelvic and abdominal ultrasonography.** The patient on peritoneal dialysis with a suspected pelvic or ovarian lesion should undergo ultrasound scanning of the involved area. In those instances where pelvic pathologic changes cannot be visualized without distending the bladder, the bladder can be filled via a Foley catheter.
4. **Transvaginal ultrasound.** It is possible to delineate pelvic abnormalities more clearly using transvaginal ultrasound, because of the proximity of the probe to the pelvic organs and the relatively thin vaginal vault, which enables the use of higher sound frequencies and therefore higher resolution. On the other hand, a transabdominal probe will give a more panoramic view of the pelvis, showing the interrelationship of the major anatomic structures in the pelvic organs and their possible pathology. A transvaginal probe is able to furnish a more focused image of the organ of interest, but only permits effective imaging to no more than 7–10 cm in depth.

Unlike transabdominal pelvic ultrasound, it is best for the patient to have the transvaginal ultrasound study done while her bladder is empty. Since many patients on dialysis are not able to fill their bladders unless a Foley catheter is in place and fluid instilled into the bladder, it makes sense to first perform a transvaginal ultrasound if pelvic pathology is suspected and proceed to transabdominal pelvic sonogram if the information needed cannot be obtained with the transvaginal approach. PD patients

should have the abdomen full for transabdominal ultrasound and empty for transvaginal ultrasound.

5. **Magnetic Resonance Imaging.** For women who are on PD, MRI of the peritoneal cavity can be done without any contrast, using the dialysate as contrast medium. This makes MRI of the abdomen and pelvic region the best modality to evaluate potential anatomic abnormalities in women on PD. Use of gadolinium as a contrast agent to enhance MRI should be done only after considering the very serious potential risk of nephrogenic systemic fibrosis. There is some evidence that with poststudy dialysis the risk of nephrogenic systemic fibrosis is not as high as once thought (Amet, 2014).

E. **Management.** The management of gynecologic cancers and nonmalignant tumors in women with chronic renal failure includes surgical excision and chemotherapy.

1. **Surgery.** In PD patients, any gynecologic procedure more invasive than a PAP smear (e.g., endometrial or cervical cone biopsy) should be performed with an empty peritoneal cavity. The patient should receive prophylactic antibiotics as described below.

In patients with peritoneal catheters undergoing pelvic or abdominal operations, we leave the catheter in place unless there is bacterial contamination of the peritoneal cavity. When there is a low but measurable risk of peritoneal contamination as in a vaginal hysterectomy, we administer 1.0 g of vancomycin hydrochloride and 1.0 g of cefoxitin prophylactically IV just prior to surgery. If the patient is known to be colonized with *Pseudomonas*, tobramycin 2.0 mg/kg IV should be added to the prophylactic regimen. Postoperatively, the catheter is irrigated with 500 mL of peritoneal dialysis solution three times daily to maintain patency. Irrigations are decreased to once daily when the fluid is no longer bloody. We wait 10 days to 2 weeks before using the catheter again, maintaining the patient by hemodialysis during the interim.

2. **Chemotherapy.** Use of chemotherapeutic agents in dialysis patients is beyond the scope of this Handbook.

References and Suggested Readings

- Amet S, et al. Incidence of nephrogenic systemic fibrosis in patients undergoing dialysis after contrast-enhanced magnetic resonance imaging with gadolinium-based contrast agents: the Prospective Fibrose Néphrogénique Systémique study. *Invest Radiol*. 2014;49:109–115.
- Ansari N, et al. Gynaecologic Nephrology. *Am Med J*. 2013;3:147–160.
- Barua M, et al. Successful pregnancies on nocturnal home hemodialysis. *Clin J Am Soc Nephrol*. 2008;3:392–396.
- Brost BC, et al. Effect of hemodialysis on serum progesterone level in pregnant women. *Am J Kidney Dis*. 1999;33:917–919.
- Cooper WO, et al. Major congenital malformations after first-trimester exposure to ACE inhibitors. *N Eng J Med*. 2006;354:2443–2451.
- Dimitriadis C, Bargman J. Gynecologic issues in peritoneal dialysis. *Adv Perit Dial*. 2011;27:101–105.

- Hampton HL, Whitworth NS, Cowan BD. Gonadotropin-releasing hormone agonist (leuprolide acetate) induced ovarian hyperstimulation syndrome in a woman undergoing intermittent hemodialysis. *Fertil Steril*. 1991;55:429.
- Harnett JD, et al. Recurrent hemoperitoneum in women receiving continuous ambulatory peritoneal dialysis. *Ann Intern Med*. 1987;107:341.
- Hladunewich MA, et al. Intensive hemodialysis associates with improved pregnancy outcomes: a Canadian and United States cohort comparison. *J Am Soc Nephrol*. 2014;25:1103–1109.
- Holley JL, et al. Gynecologic and reproductive issues in women on dialysis. *Am J Kidney Dis*. 1997;29:685–690.
- Holley JL. Screening, diagnosis, and treatment of cancer in long-term dialysis patients. *Clin J Am Soc Nephrol*. 2007;2:604–610.
- Hou S. Daily dialysis in pregnancy. *Hemodial Int*. 2004;8:167–171.
- Hou S. Pregnancy in women treated with dialysis: lessons from a large series over 20 years. *Am J Kidney Dis*. 2010;56:5–6.
- Kajbaf S, Nichol G, Zimmerman D. Cancer screening and life expectancy of Canadian patients with kidney failure. *Nephrol Dial Transplant*. 2002;17:1786–1789.
- Kramer HM, Curhan GC, Singh A. Permanent cessation of menses and post menopausal hormone use in dialysis dependent women. *Am J Kidney Dis*. 2003;41:643–650.
- Lew SQ. Hemoperitoneum: bloody peritoneal dialysate in ESRD receiving peritoneal dialysis. *Perit Dial Int*. 2007;27:226–233.
- Lin HF, et al. Increased risk of cancer in chronic dialysis patients: a population based cohort study in Taiwan. *Nephrol Dial Transplant*. 2012;27:1585–1590.
- Ma TL, Wang CL, Hwang JC. Recurrent peritonitis episodes in a continuous ambulatory peritoneal dialysis patient after gynecologic procedures. *Perit Dial Int*. 2012;32:113–114.
- Mattix H, Singh AK. Estrogen replacement therapy: implications for post menopausal women with end-stage renal disease. *Curr Opin Nephrol*. 2000;9:207–214.
- Nadeau-Fredette AC, et al. End-stage renal disease and pregnancy. *Adv Chronic Kidney Dis*. 2013;20:246–252.
- Nakamura Y, Yoshimura Y. Treatment of uterine leiomyomas in perimenopausal women with gonadotropin-releasing hormone agonists. In: Pitkin RM, Scott JR, ed. *Clin Obstet Gynecol*. 36: 9/93
- Navaneethan SD, et al. Prevalence and correlates of self reported sexual dysfunction in CKD: a metaanalysis of observational studies. *Am J Kidney Dis*. 2010;56:670–685.
- Okundaye IB, Abrinko P, Hou S. A Registry for Pregnancy in Dialysis Patients. *Am J Kidney Dis*. 1998;31:766–773.
- Poole CL et al. Aseptic peritonitis associated with menstruation and ovulation in a peritoneal dialysis patient. In: Khanna R, et al. eds. *Advances in Continuous Ambulatory Peritoneal Dialysis*. Toronto: Peritoneal Dialysis Bulletin; 1987.
- Potluri K, et al. Beta HCG in a pregnant dialysis patient: a cautionary tale. *Nephrol Dial Transplant Plus*. 2011;4:42–43.
- Shan HY, et al. Use of circulating antiangiogenic factors to differentiate other hypertensive disorders from preeclampsia in a pregnant woman on dialysis. *Am J Kidney Dis*. 2008;51:1029–1032.
- Stengel B. Chronic kidney disease and cancer: a troubling Connection. *J Nephrol*. 2010;23:253–262.

Strippoli GFM, et al. Sexual dysfunction in women with ESRD requiring hemodialysis. *Clin J Am Soc Nephrol.* 2012;7:974–981.

Weisbord SD. Female sexual dysfunction in ESRD: an underappreciated epidemic? *Clin J Am Soc Nephrol.* 2012;7:881.

Web References

National Collaborating Center for Women's and Children's Health. Hypertension in pregnancy: the management of hypertensive disorders during pregnancy. CG107 Hypertension in pregnancy: full guideline, <http://www.nice.org.uk/guidance/CG107>. Accessed July 7, 2014.

Chronic kidney disease (CKD) patients are subject to a wide variety of pathophysiologic processes that challenge the structural and functional integrity of both central and peripheral nervous systems. Neurologic dysfunction can be episodic or chronic and can reflect a wide range of humoral, metabolic, inflammatory, and vascular insults. These may be attendant to the underlying conditions that have led to end stage kidney disease (ESKD), advanced uremia itself, or to the dialysis procedure (on a variety of levels). The integrated product of these factors contributes to neurocognitive performance, depression, health-related quality of life, and the ability of the patient to tolerate the dialysis procedure whilst leading a full and independent life in the hours spent not actually receiving dialysis. This chapter is limited to discussion of the brain and peripheral nervous system, and encompasses sleep disorders and combination pathologies such as restless legs syndrome.

- I. **CENTRAL NERVOUS SYSTEM.** When considering dysfunction of the central nervous system (CNS) in the dialyzed uremic patient, it's important to consider the range of structural abnormalities that can occur, as well as the impact of the uremic milieu. Many of these considerations are often present together and may result in compound effects.
 - A. **Intracranial bleeding and ischemic stroke.** Spontaneous subdural hemorrhage is common. The rate has been increasing over recent years, possibly associated with increased use of anticoagulation in patients with atrial fibrillation in an attempt to reduce the risk of stroke. Intracranial or subarachnoid bleeds are not uncommon (even during the dialysis procedure itself). They are a particular problem in patients with polycystic kidneys who may have intracranial aneurysms. Headache occurs in both disequilibrium and early cerebral hemorrhage, but the pattern of recovery is different and new onset headache may need to be investigated for possible intracranial bleeding by CT or MRI (embracing the limitations of contrast use in this population). Heparin-free dialysis should be used. Both ischemic and hemorrhagic strokes are common and catastrophic events, but usually present little diagnostic challenge. Both short- and long-term management are controversial with there being very little data relating to the application of intracerebral thrombolysis or primary/secondary preventative measures in hemodialysis patients. The efficacy and safety profile of all of these interventions may very well be very different in dialysis patients compared with the general population, where they were developed.
 - B. **Subclinical brain structural abnormalities.** There are several pathologies detectable by brain MRI

in the brain of dialysis patients. These may be entirely asymptomatic or linked to more subtle defects in neurocognitive function, often only apparent on specific testing. They are often progressive. Many of these changes do not appear to be associated with classical cardiovascular risk factors, and instead seem to be predominantly driven by other factors such as microvascular disease, inflammation, and challenged perfusion (both in general and episodically during hemodialysis). These abnormalities range from silent cerebral infarct to changes both in the white matter (leukoaraiosis) and grey matter (cortical atrophy).

1. **Silent cerebral infarcts.** Nakatani and coworkers examined the hypothesis that hemodialysis patients develop silent cerebral infarcts (SCI). These silent infarcts are mainly subcortical and lacunar without causing any neurologic deficit, but are thought to be a risk factor for developing symptomatic infarct or hemorrhagic strokes. Nakatani and coworkers (2003) examined a group of 50 hemodialysis patients and found that in those who developed SCI, associated risk factors were smoking, lower HDL cholesterol, higher uric acid levels, and higher levels of hepatocyte growth factor. Echocardiographically, the group who developed SCI had higher interventricular septal thickness at the end of diastole, higher posterior wall thickness at the end of diastole, and higher left ventricular mass index. On 24-hour blood pressure monitoring, the group with silent infarcts was not more hypertensive in general, but did not evidence the healthy pattern of a nocturnal fall in blood pressure. One possible mechanism in the causation of SCI might be microbubbles generated during the hemodialysis procedure and undetected by the air alarms may find their ways into the cerebral circulation and cause ischemic damage (Forsberg, 2010).
2. **Cerebral atrophy.** Cerebral (cortical) atrophy has been identified in hemodialysis patients through both CT and MRI-based studies. The degree of cerebral atrophy is associated with duration of dialysis. Cerebral blood flow is lower in between dialysis sessions and higher during hemodialysis. These hemodynamic changes and changes in cerebral oxygenation are less pronounced in peritoneal dialysis patients, suggesting that there may be iatrogenic cerebral effects of hemodialysis (Prohovnik, 2007).
3. **Leukoaraiosis.** Leukoaraiosis describes nonspecific changes in the brain white matter caused by loss of axons and myelin. This is usually associated with ischemic injury. The MRI appearance is that of high signal intensity on T2-weighted images. Leukoaraiosis is a risk factor for developing dementia, mobility problems, and strokes, and has been described in the literature primarily as an age-related phenomenon. In the non-CKD population, leukoaraiosis is associated with reduction in cognitive function and with increased prevalence and severity of depression.

Several studies have identified this pattern of structural brain injury as being common in hemodialysis patients; in fact, a universal finding after only 3 months of hemodialysis. The severity of reduction in cognitive function was proportional to the distribution and amount of white matter injury, and in turn this was proportional to the degree of cardiovascular instability during hemodialysis sessions (Eldehni, 2014).

C. **Humoral abnormalities influencing brain function**

1. **Uremic encephalopathy.** Encephalopathy is a cardinal feature of untreated uremia. Initial

manifestations are subtle: flattened affect, irritability, and poor rapport with others. Formal evaluation at this stage may reveal patchy cognitive or psychomotor behavior. Event-related brain potentials (stimulus-evoked averaged electroencephalogram [EEG] waveforms) may be abnormal. As uremia advances, lassitude gives way to disorientation, confusion, delirium, stupor, and, preterminally, coma. There are accompanying motor disturbances: tremulousness, myoclonus, and asterixis (flapping tremor). These major signs of uremic encephalopathy will reliably regress within a week or so of initiation of regular dialysis; failure to do so should lead to an alternative or additional diagnosis.

2. **Metabolic and electrolytic causes.** Hypercalcemia from any cause (often relating to CKD mineral bone disorder or its treatments) can present as an acute confusional state or coma. Severe low or high serum sodium levels can also result in a predominantly neurologic presentation. The presence of cerebral atrophy often makes the dialysis patient remarkably resistant to the development of severe cerebral edema as a result of abnormal tonicity. Hypoglycemia may present in diabetic patients due to inappropriate hypoglycemic therapy, or to further reductions in residual renal function with reduced insulin metabolism. In nondiabetic patients hypoglycemia may occur as a result of reflex hyperinsulinemia after exposure to hemodialysis solutions containing higher glucose concentrations, or as a hypoglycemic response to glucose-free dialysate.

Acute aluminum intoxication can present with an acute neurotoxicity syndrome characterized by agitation, confusion, seizures, myoclonic jerks, and coma. This is quite uncommon now compared with the bygone era when there were less stringent water treatment standards and heavy reliance on aluminum-containing salts for oral binding of phosphate. Still, even today, the acute syndrome can be seen when dialysis solution becomes highly contaminated with aluminum for some reason, or in the course of deferoxamine therapy. In this setting, the plasma aluminum level is usually more than 500 mcg/L (19 μ mol/L), and typical EEG changes (multifocal bursts of slow or delta wave activity, often accompanied by spikes) are present. More information about aluminum toxicity is given in Chapter 36 on mineral bone disorders.

3. **Infection and inflammation.** Both systemic and local infection and inflammation can affect the brain in dialysis patients. Sepsis in this patient group not uncommonly presents without a typical pyrexial response (especially in the elderly), and the initial manifestation can be central obtundation. Dialysis patients are immunosuppressed both as a consequence of the uremic state and of immunomodulatory therapy given as part of treatment of their underlying disease. They also are at higher risk of a wide range of encephalitic or meningitic processes, especially those with more “slow burning” presentations such as tuberculous meningitis.

Endotoxemia is another important factor that could be implicated in the pathogenesis of hemodialysis-induced brain injury. Endotoxemia is well described in CKD5D patients, and it induces a systemic proinflammatory state (McIntyre, 2011). These patients suffer gut hypoperfusion and increased bowel permeability, resulting in bacterial and endotoxin translocation to the circulation. The level of resultant circulatory stress is associated with the severity of endotoxemia. Hemodialysis patients

are in a chronic state of endotoxemia, with acute exacerbations from recurrent mesenteric ischemia accompanying each hemodialysis session. The repeated endotoxemic insult may also aggravate the effects of hemodialysis on cerebral perfusion with secondary ischemic white matter subcortical brain injury.

D. Acute episodic dysfunction

1. **Disequilibrium syndrome.** Rapid correction of advanced uremia is sometimes complicated by a characteristic syndrome of neurologic dysfunction appearing in the last part of dialysis or shortly afterward. Hemodialysis is usually involved, but disequilibrium can also occur with peritoneal dialysis. In its mildest form, the syndrome is limited to restlessness, headache, nausea, and vomiting; more severe manifestations include confusion and major seizures. The syndrome is believed to be caused by brain swelling due to a lag in osmolar shifts between blood and brain during dialysis, but changes in brain pH may also play a role. Disequilibrium occurs in a major form in previously undialyzed patients, but minor features may complicate chronic therapy. Disequilibrium is more likely to occur when patients with advanced states of uremia are dialyzed for excessive lengths of time during their first treatment sessions, especially in the era of using higher-efficiency dialyzers in this setting. The initial dialyses should be relatively short, so as to reduce elevated serum urea levels slowly over the course of several days. The routine use of anticonvulsants in this setting should be avoided.
2. **Other factors effecting tonicity.** Rapid shifting of other osmotically active substances (glucose and sodium) may also contribute to presentation with acute obtundation, and further consideration may need to be given to glucose level correction and careful individualization of dialysate conductivity to minimize these additional insults.
3. **Dialysis-induced reduction in cerebral perfusion/oxygenation.** Failure to maintain blood pressure during dialysis may also precipitate an acute reduction in consciousness levels. Diagnosis and management of intradialytic hypotension is dealt with in more detail in other sections of this handbook, but immediate recognition and corrective measures are essential to restore normal functioning and reduce the risk of a watershed area cerebral infarct. Such episodes may also be important in driving chronic subclinical white matter injury.
4. **Coning.** Uncal and cerebellar tonsillar herniation can occur without other coexisting pathologic lesions. This can present with a severe dialysis-induced headache and a reduced level of consciousness, and result in death. More commonly, this presentation occurs in the setting of either inherited abnormalities predisposing to coning (such as the so-called *Chiari malformation*, where there is partial hindbrain herniation through the foramen magnum, sometimes seen in *spina bifida*) or after neurosurgery. Cerebrospinal fluid diversion and, in particular, shunt malfunction can also increase the risk of dialysis-induced brainstem herniation. Limitation of ultrafiltration rate and careful matching of dialysate tonicity to plasma are the essentials of management in this setting.
5. **Nonconvulsive *status epilepticus*.** *Status epilepticus* may present with confusion or more severe reductions in the level of consciousness. When occurring without obvious convulsive activity (Iftikhar, 2007), it may mimic collapse from either a catastrophic

intracerebral event (although with normal brain imaging) or acute cardiovascular insufficiency.

Typically, the EEG in nonconvulsive *status epilepticus* shows generalized spike-and-wave complexes at 3 Hz or repetitive generalized or focal spikes, sharp-waves, and spike-and-wave complexes at $> 4/\text{sec}$. Events that can precipitate nonconvulsive status include alcohol, drug withdrawal, infection, hypoxia, cerebrovascular accident, menstruation, cyclosporine A therapy, malignancy, and antibiotic neurotoxicity. Antibiotics which have been reported to cause seizures in patients with decreased renal function, include penicillins, cephalosporins, imipenem/cilastatin, and quinolones. Management is focused on dealing with precipitating causes and use of standard anticonvulsant drugs for the management of acute epilepsy.

E. **Differential diagnosis of acute obtundation syndrome, dialysis disequilibrium, and chronic dementia.** The differential diagnosis for each of these conditions is large. A partial list to consider when confronted with a patient with acute obtundation is given in Table 40.1. Mimics of dialysis disequilibrium are given in Table 40.2, and those for chronic dementia in Table 40.3. Proposed management strategies for acute obtundation are shown in Figure 40.1 and for chronic obtundation in Figure 40.2.

F. **Diagnosis and management of epileptic seizures**

1. **Etiology.** Seizures are not uncommon in dialysis patients. Generalized seizures are an integral feature of advanced uremic encephalopathy. Seizures can also be a manifestation of severe disequilibrium syndrome, as discussed above. Table 40.4 lists the most common associated conditions. Intracranial hemorrhage commonly leads to focal seizures, while most of the other causes lead to generalized seizures.

Seizures characterize both aluminum-induced encephalopathy and severe hypertension. In children with renal failure, the incidence of seizures is higher than in adults. Predialysis hypocalcemia can result in seizures during or soon after dialysis because of the fall in serum ionized calcium level associated with rapid correction of acidosis. As in any patient with hypocalcemia, associated (and often causal) hypomagnesemia should be excluded. Hypoglycemia can occur if glucose-free dialysis solution is used.

Seizures tend to be more common in patients taking a variety of “epileptogenic” drugs. Penicillins and cephalosporins are common offenders, especially if high doses are given or when provision for dose reduction in the setting of CKD has not been made. A selection of other epileptogenic drugs is given in Table 40.4. A variety of poisonings in dialysis patients can also present with seizures, including star fruit ingestion (numbness, weakness, obtundation, seizures). Some anticonvulsant drugs may have enhanced removal by high-efficiency hemodialysis (e.g., carbamazepine) and this may result in precipitation of seizures due to reduction of drug plasma levels below the therapeutic threshold.

Uremic encephalopathy

Drug intoxication (by drugs renally excreted)

Antibiotics

Antiviral agents

Opiates

Anticonvulsants

Central nervous system infection

Meningitis

Encephalitis

Endocarditis

Hypertensive encephalopathy

Hemorrhage

Subarachnoid

Subdural

Intracranial

Acute aluminum toxicity (coingestion of citrate, highly contaminated dialysate)

Wernicke's encephalopathy (in patients with vomiting, poor food intake)

TABLE

40.2

Conditions That May Mimic Dialysis Disequilibrium Syndrome

Intracranial bleeding

Subdural

Subarachnoid

Intracranial

Metabolic disorders

Hyperosmolar states

Hypercalcemia

Hypoglycemia

Hyponatremia

Cerebral infarction

Hypotension

Excessive ultrafiltration

Cardiac arrhythmia

Myocardial infarction

Anaphylaxis

- Idiopathic presenile dementia
- Vascular dementia
- Depression
- Chronic subdural hematoma
- Drug intoxication
- Metabolic disorders
 - Hypercalcemia (autonomous hyperparathyroidism or iatrogenic)
 - Hypoglycemic brain damage
- Demyelination syndrome secondary to hyponatremia
- Uremia (underdialysis)
- Hydrocephalus (possibly secondary to subarachnoid hemorrhage)
- Anemia
- Thiamine deficiency (chronic Wernicke–Korsakoff syndrome)
- Chronic infection
- Aluminum encephalopathy (dialysis dementia)

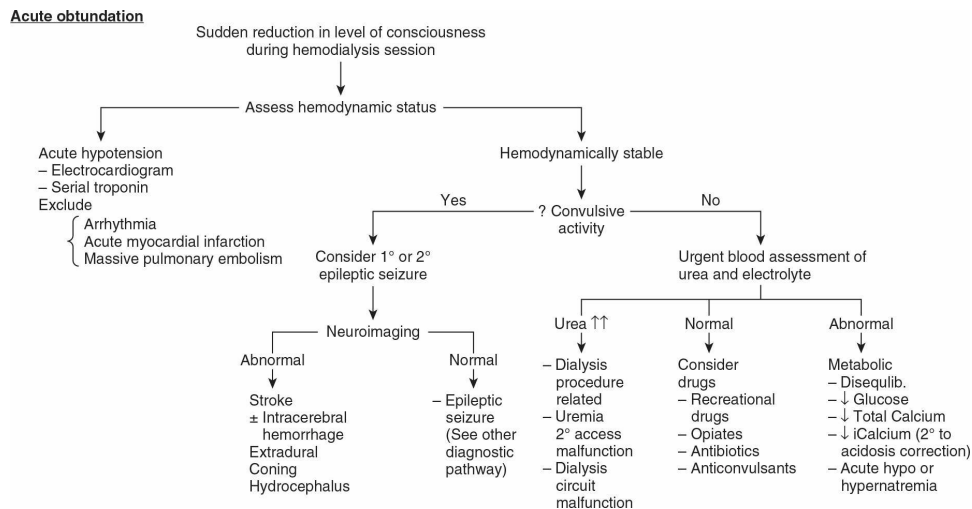

FIGURE 40.1 Evaluation and Management of Acute Obtundation.

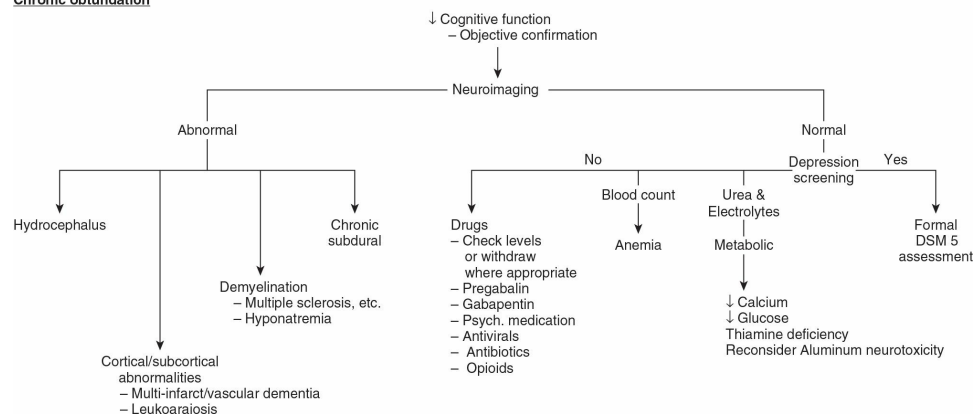

FIGURE 40.2 Evaluation and management of chronic obtundation. DSM 5, Diagnostic and Statistical Manual of Mental Disorders, 5th edition.

TABLE

40.4

Seizures in Dialysis Patients

Etiology

Disequilibrium syndrome

Hypertensive encephalopathy

Intracranial hemorrhage

Drug-induced reduction in fit threshold

Alcohol withdrawal

Metabolic

Hypoglycemia

Hypocalcemia

Hyperosmolality due to peritoneal dialysis

Hypernatremia (accidental due to hemodialysis machine malfunction) or hyponatremia

Severe hypotension

Anoxia

Arrhythmia

Uremic encephalopathy (unlikely in dialysis patients)

Toxins (star fruit ingestion)

Anaphylaxis

Aluminum encephalopathy

Air embolism

Prevention

Identification of susceptible subgroups

Predialysis serum urea nitrogen level >130 mg/dL (46 mmol/L)

Severe hypertension

Previous seizure disorder

Alcoholism

Predialysis hypocalcemia (<6 mg/dL, 1.5 mmol/L) with acidosis

Limiting initial dialysis session blood flow rate, length and ultrafiltration rate
Maintenance of dialysis solution sodium concentration at or above plasma level
Use of 3.5 mEq/L (1.75 mM) or 4.0 mEq/L (2.0 mM) calcium bath in hypocalcemic patients;
administration of IV calcium during dialysis if necessary
Scrupulous attention to blood pressure control during EPO therapy
Limiting exposure to ethanol and to “epileptogenic” drugs

Penicillins
Fluoroquinolones
Cyclosporine
Meperidine (Demerol)
Theophylline
Metoclopramide
Lithium

Therapy

Stopping dialysis
Maintenance of airway patency
Drawing blood for glucose, calcium, and other electrolytes
If hypoglycemia is suspected, administration of IV glucose
Administration of IV diazepam or lorazepam, and also phenytoin if required
Treatment of metabolic disturbance if present

- 2. Diagnosis.** Electroencephalography is of somewhat limited value in the evaluation of seizures in dialysis patients. Patients with renal failure rarely have a normal EEG, the most common abnormal findings being reduced voltage, loss of alpha activity, and the appearance of periodic, symmetric, and usually frontal, delta wave slowing. In any case, the EEG is unlikely to distinguish between the various causes of seizures listed in Table 40.4, and a search for aluminum poisoning, an underlying metabolic cause, a complication of the dialysis procedure, or a structural intracranial lesion is important not to neglect.
- 3. Prevention.** Susceptible patients can often be identified (see Table 40.4). The prevention of dialysis disequilibrium has already been discussed. Patients with low serum ionized calcium levels can be given intravenous calcium at the start of dialysis, and a dialysis solution with a higher calcium concentration can be used. Blood pressure needs to be carefully regulated.
- 4. Management.** One suggested algorithm is shown in Figure 40.3. The emergency treatment of convulsions should begin by stopping dialysis and ensuring patency of the airway. Blood should be sampled immediately and serum glucose, calcium, and other electrolyte values determined. IV glucose should be administered if hypoglycemia is suspected. If seizures persist, benzodiazepines are appropriate drugs for initial use. Further management of refractory seizure activity needs to be performed with appropriate full monitoring of the cardiovascular status of the patient in a higher-

dependency clinical area. Additional agents can be utilized. Phenytoin is effective, but must be used with caution and appropriate monitoring of cardiac rhythm. A loading dosage of phenytoin, 10–15 mg/kg, can be given by slow IV infusion at a rate no greater than 50 mg/min, during constant electrocardiographic monitoring to guard against phenytoin-induced bradycardia, atrioventricular conduction block, or other arrhythmias. Other agents that may be appropriate include IV valproate.

5. **Drug prophylaxis.** The prophylaxis of recurrent convulsions is usually effective with administration of phenytoin, carbamazepine, or sodium valproate. Fits relating to dialysis encephalopathy respond best to benzodiazepines, particularly clonazepam.

a. **Phenytoin.** Phenytoin absorption is slow and erratic. Its hepatic metabolism is concentration dependent and saturable, and distribution and elimination vary. Phenytoin protein binding is decreased and the distribution volume increased in renal failure. With any given total serum phenytoin level, the concentration of active, free drug is higher in uremic patients than in patients with normal renal function. Most clinical laboratories measure the total serum drug concentration, and a low total phenytoin level in a patient with renal failure should not be misinterpreted as subtherapeutic. Physical findings such as nystagmus may be helpful in deciding not to increase the dose. Seizures are also a manifestation of phenytoin excess, and small dosage increases may result in disproportionately large increases in the serum drug level. Dose increments should be small, sufficient time should be allowed for the patient to reach steady-state drug levels, and measurement of free serum phenytoin concentration should be done frequently in uremic patients who are not responding to therapy.

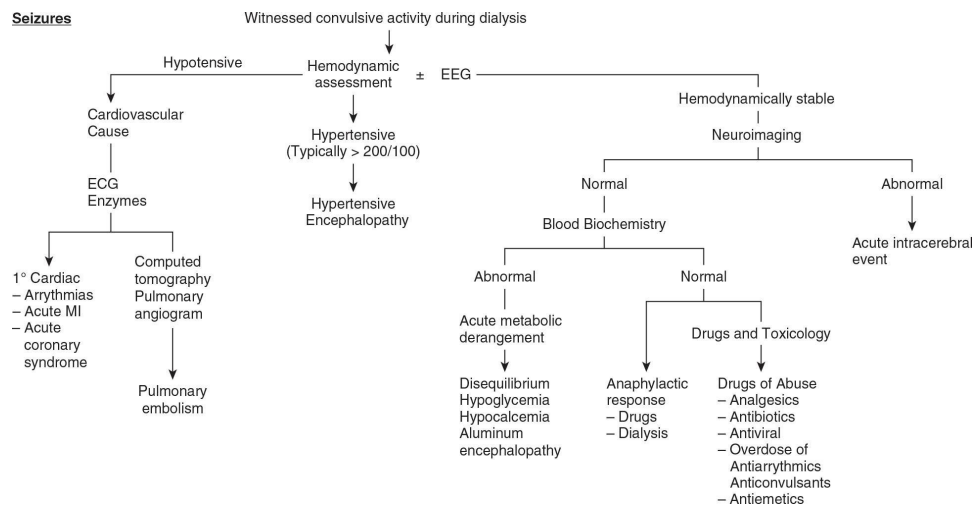

FIGURE 40.3 Evaluation and management of seizures.

b. **Other agents.** Other newer anticonvulsants may also be suitable (with less risk of sedation, wider therapeutic windows, or as part of multiple drug regimes). Dialysis clearance of many of these drugs has not been subjected to rigorous patient-based evaluation. This is especially true when managing acute kidney injury and adding in alternative dialysis/CRRT (continuous renal replacement therapy) schedules. Reference to up-to-date dose modification guidelines and

sources is strongly recommended. Table 40.5 is provided as initial guidance to some of the therapeutic challenges posed utilizing this group of drugs in dialysis patients.

Carbamazepine, ethosuximide, and valproic acid can be given in 75%–100% of the usual dosage to dialysis patients. Protein binding of valproic acid may be reduced in uremia. Carbamazepine is not well removed by dialysis. Valproic acid is dialyzable when high-flux dialyzers are used. Ethosuximide is substantially dialyzable, and a posthemodialysis supplement may be required. Primidone is 40% renally excreted and is moderately dialyzable. Primidone should be used with extreme caution in dialysis patients; the need for a substantially reduced dosage should be anticipated, and a posthemodialysis supplement may be required. Phenobarbital can be given in 75%–100% of the usual dosage. Phenobarbital is dialyzable, and a dose should be scheduled after the dialysis treatment. Vigabatrin, a γ -aminobutyric acid-transaminase inhibitor, is eliminated by the kidney; major dosage reduction is necessary in dialysis patients (see Table 40.5).

G. Chronic neurologic states

1. **Neurocognitive decline and dementia.** Reduced cortical function and dementia is common in dialysis patients, with characteristic patterns of memory loss and impaired cognition. This is in part due to a predominantly elderly population with a high burden of comorbid conditions, and all of the recognized risk factors for the development of dementia. Widespread atheromatous plaques are found commonly in dialysis patients, predisposing them to multi-infarct dementia. At autopsy, the brains of these patients are seen to contain multiple lacunar infarcts in the basal ganglia, thalamus, internal capsule, pons, and cerebellum. Clinically, these patients present with a progressive stepwise decline in intellectual and neurologic functioning, and may have a variety of neurologic signs according to the site of the infarcts. The diagnosis of chronic subdural hematoma as a complication of anticoagulant treatment should always be borne in mind as the disease may present with pseudodementia, drowsiness, and confusion. The diagnosis is made by appropriate neuroimaging. Both aluminum and iron can be found deposited in the brain in an accelerated fashion, and this can be associated with progressive reduction in cortical function. Metabolic disorders, including drug intoxication, are excluded by simple laboratory tests and a careful drug ingestion history. Lastly, thiamine deficiency has been described in a group of patients from Taiwan (Hung, 2001).

TABLE

40.5

Pharmacokinetics of Anticonvulsants in Dialysis Patients

Drug	Renal Excretion (%)	Nonuremic Dosage Range (mg/d)	Usual Dosage for ESKD Patients (% of nonuremic dose)	Plasma Half-life (hr)		Removed by Hemodialysis	Notes
				Nonuremic Patients	ESKD Patients		
Carbamazepine	3	600–1,600	100	10–20	Same ^a	No	NU-TPL = 4–12 mg/L
Clonazepam	<1	0.5–20.0	100	17–28	Same ^a	No	
Diazepam	<1	5–10 (IV) ^b	750	20–70	Same ^a	No	Active metabolites may accumulate in renal failure
Ethosuximide	>30	750–2,000	100	50–60	Same ^a	Yes	NU-TPL = 40–100 mg/L
Phenobarbital	10–40	60–200	75	100	120–160	Yes	
Phenytoin	<5	300–600	100	10–30	Same ^a	±	NU-TPL = 10–20 mg/L
Primidone	40 ^c	500–2,000	Caution	5–15	Same ^a	Yes	ESKD-TPL = 4–10 mg/L due to decreased protein binding
Valproic acid	<4	750–2,000	75–100	6–16	Same ^a	±	NU-TPL = 50–120 mg/L
Vigabatrin	50	2,000–4,000	25	7	14	Unknown	New drug; little experience in dialysis patients

ESKD, end-stage kidney disease; ESKD-TPL, therapeutic plasma concentration in dialysis patients; NU-TPL, therapeutic plasma concentration in nonuremic subjects.

^aInferred (estimated) from pharmacokinetic considerations.

^bInitial dose.

^cExtensive metabolism to phenylethylmalonamide (PEMA) and phenobarbital. Primidone and PEMA are excreted unchanged, and 10%–40% of phenobarbital is excreted by the kidneys.

- Subclinical cognitive dysfunction and depression.** Subclinical uremic encephalopathy may be present in chronic dialysis patients if inadequate dialysis is delivered. Severe depression (and sometimes anxiety) can impair cognitive function, but these may be detected only if detailed and regular neuropsychological assessment is undertaken.

A more common pattern, however, is as the result of widespread subcortical white matter brain injury. Leukoaraiosis has been described as a risk factor for developing dementia, mobility problems, and strokes and represents accelerated vascular aging. It is common in dialysis patients and, as with other forms of brain injury, is associated with inflammation, hypertension, and vascular disease. This form of subcortical injury occurs precisely in the vascular watershed area of the brain, where episodic intradialytic reduced perfusion would be expected to have its maximal effect. The few studies that have fully assessed cognitive loss in hemodialysis patients have identified relative preservation of memory and vocabulary (cortical pattern), but have shown significant loss of primarily subcortical functions relating to decision making and executive functioning.

Of even more potential impact is the recent realization that subcortical subclinical ischemic white matter changes are associated with the interruption of intracerebral circuits, the loss of “thymic balance,” and the development of clinical depression. These circumstantial data, in combination with the temporal colocalization of significant increase in social dependency, clustered around initiation and the first 6 months of dialysis, raise the fascinating possibility of a new biologic basis for depression and increasing social dependency in hemodialysis patients.

- SLEEP-RELATED DISORDERS.** Surveys of dialysis patients report that 40%–50% have one or more sleep complaints, and more than 50% studied in a sleep disorders laboratory have a sleep disorder objectively documented by polysomnography. Dialysis patients complain frequently of “insomnia” independent of anxiety or depression. They may have difficulty falling asleep or staying asleep. Patients often complain of awakening frequently during the night without apparent cause. Excessive daytime sleepiness (EDS) is a frequent complaint. It is common to enter a dialysis unit during the daytime and find many patients fast asleep while undergoing dialysis. Chronic daytime sleepiness may affect cognitive functioning, interfere with activities of daily living, and decrease quality of life. Daytime sleepiness may also interfere with the patient’s ability to work and place him or her in danger while driving or operating heavy

equipment.

- A. **Sleep apnea.** Studies have found sleep apnea in 50%–75% of dialysis patients with sleep-related complaints. Sleep apnea can be classified as obstructive, central, or mixed. Obstructive sleep apnea is a very common medical disorder resulting from a collapse of the upper airway during sleep in the presence of continuing respiratory effort. It is often associated with loud snoring, gasping, and snorting sounds during sleep. It is reported to occur in 4% of normal men and 2% of women 30–60 years of age. As many as 81% of elderly nursing home patients are reported to have sleep apnea. Obstructive sleep apnea has been reported to be associated with increased morbidity and mortality. This morbidity is most often related to cardiovascular (often associated with sympathetic overdrive) and cerebrovascular pathophysiologic processes, as well as accidents due to sleepiness. This obstruction appears to be largely due to upper airway edema and congestion/distortion of the nasopharynx. While dialysis patients may have obstructive sleep apnea, they also commonly have central sleep apnea. In central apnea, neither respiratory effort nor airflow is present, suggesting a malfunction in the respiratory centers of the brain. Mixed apneas, which refer to central sleep apnea with an obstructive component, are not uncommon in the dialysis population.
- B. **Restless legs syndrome and periodic leg movements in sleep.**
1. **Restless legs.** One of the most common complaints among ESKD patients is restless legs syndrome (RLS). RLS is a subjective complaint for which there is no objective test. Patients often describe an irritating sensation deep in the muscles of the lower leg, particularly in the calf muscle. Patients can relieve this sensation only by moving their legs and feet. The irritating sensation typically appears when patients are at rest, often in the hours prior to the patient's usual bedtime. RLS may significantly delay sleep onset.
 2. **PLMS.** Periodic leg movements in sleep (PLMS) is a common sleep disorder occurring with increased incidence with age and is common in the elderly of the general population. It generally consists of a dorsiflexion of the foot or movement of the lower limb lasting 2–4 seconds and repeating every 20–40 seconds numerous times. It occurs primarily in the first third of the sleep period during non-rapid eye movement sleep. Each movement may result in a brief arousal from sleep and can be the source of complaints about unrefreshing sleep and daytime fatigue. PLMS occurs in approximately 80% of patients who complain of RLS. PLMS is found in a very high percentage of ESKD patients. Dialysis patients with PLMS have a much higher number of movements per hour of sleep than patients in the general population with PLMS. In one case series of 45 dialysis patients, 71% had significant PLMS, with several patients having more than 1,500 leg movements in a single night. Many of the PLMS incidents were associated with repetitive arousals, resulting in very poor-quality sleep, daytime complaints of fatigue, and increased mortality. Both presence of sleep apnea and a high PLMS index (e.g., more than 35 leg movements per hour of sleep) are associated with elevated mortality rates. It is not known whether this is causal or merely associative, and whether treatment will improve survival in such patients also has not been determined.

3. **Diagnosis**

- a. **History.** A sleep history can easily be obtained using a questionnaire or brief interview. Patients or bed partners should be questioned regarding quantity and quality of nocturnal sleep, number of awakenings from sleep, whether sleep is restorative, snoring, gasping, breathing pauses during sleep, lower limb movements (kicking) while awake or asleep, daytime fatigue, or inappropriate napping. Ingestion of medications and social habits (e.g., excess caffeine) associated with excess irritability should be reviewed.
- b. **Polysomnography.** Sleep disorders such as sleep apnea and PLMS in sleep are easily identifiable via standard diagnostic polysomnography (sleep studies). These studies are usually performed in specially equipped laboratories found in many hospitals. Polysomnography generally encompasses simultaneous electroencephalography, electrooculography, electromyography, and electrocardiography, as well as monitoring of breathing sounds, respiratory effort and airflow, arterial oxygen saturation, and leg movements during the patient's usual sleep period.

4. **Treatment of sleep apnea**

- a. **Medication** has not been shown to be effective in the treatment of obstructive sleep apnea. Benzodiazepines are contraindicated for obstructive sleep apnea, as are other CNS depressants, because they may result in longer apneas, greater O₂ desaturation, and more severe sleep fragmentation with consequently greater daytime fatigue.
- b. **Nocturnal dialysis.** Both nocturnal hemodialysis and nocturnalycler-assisted PD (Tang, 2006) have been reported to bring about improvement in sleep apnea. The responsible mechanisms have not been established, but probably the provision of nocturnal ultrafiltration and improved volume control improves upper airway edema (directly measured by MRI), and this impacts on the obstructive element of sleep apnea (Elias, 2013).
- c. **Continuous positive airway pressure (CPAP).** CPAP consists of the administration of positive air pressure via the mouth or nares. The positive air pressure splints the upper airway open, effectively preventing obstruction. This has been shown to be an effective treatment for sleep apneas in the dialysis population, whether the cause is obstructive, central, or mixed. Noncompliance is a problem, however, in patients who use CPAP treatment for obstructive sleep apnea.
- d. **Supplementary O₂.** Administration of low-flow supplemental O₂ has been reported to be a successful treatment for central sleep apnea in some recent studies. However, if obstructive sleep apnea is also present, low-flow O₂ may result in a lengthening of apnea duration.
- e. **Surgery.** Various surgical approaches have been used for the treatment of obstructive sleep apnea. These usually involve the surgical reduction or removal of the uvula and tissues of the soft palate. Surgeries for obstructive sleep apnea have been reported to have an overall success rate of 50%.

5. Treatment of RLS/PLMS

- a. **Conservative measures.** Iron repletion is helpful in the general population, but is very rarely a problem in dialysis patients owing to continual monitoring of iron status. Nonetheless, iron deficiency should be avoided. General advice about caffeine, alcohol, and nicotine avoidance is sometimes helpful. Regular stretching, exercise, massage, and either hot or cold baths may ameliorate symptoms. Chronic insomnia from restless legs adds to the burden of mood disturbance, which may perpetuate a cycle of poor sleep.
- b. **Medication.** Dopamine precursors or agonists such as l-dopa have been shown to reduce the number and severity of both disorders and are considered the treatment of choice by many. Benzodiazepines, such as clonazepam, have been used for many years. Controversy exists as to whether benzodiazepines actually reduce the number of movements or simply suppress arousal. Longer-acting dopamine agonists such as ropinirole are now available but should be used cautiously in ESKD patients.
- c. **Transplantation.** Complete resolution of both sleep apnea and RLS/PLMS has been reported following kidney transplantation.

III. PERIPHERAL NEUROPATHY

- A. **Uremic neuropathy.** Uremic neuropathy is a distal, symmetric, mixed motor and sensory polyneuropathy. It typically involves the legs more than the arms. Clinical manifestations include paresthesia in the feet, painful dysesthesia, ataxia, and weakness. The sense of position and the vibratory threshold often are impaired. Physiologic studies show slowing of motor nerve conduction and sensory action potentials. The condition is due to one or more toxins retained in uremia and inadequately removed by dialysis. In patients with coexisting diabetes, the development of disabling neuropathy can be rapid, and unraveling the contribution of each cause may be difficult.

With effective dialysis, clinical uremic neuropathy is unusual, but subclinical manifestations can be detected in over 50% of patients. Serial electrophysiologic monitoring has been used to assess the adequacy of dialysis schedules, but is not routinely employed. If clinical signs of peripheral neuropathy appear, then the adequacy of the dialysis treatment should be carefully evaluated using urea kinetic modeling. A switch to a high-flux membrane or hemodiafiltration to increase the removal of middle molecules may be of benefit. More frequent hemodialysis, and especially six times per week nocturnal hemodialysis, may improve neuropathy, but solid data on neuropathy are not yet available. Neuropathy is most reliably reversed by successful renal transplantation.

1. **Differential diagnosis.** Uremic neuropathy has to be distinguished from disturbed peripheral nerve function owing to an underlying systemic disease (e.g., amyloidosis or diabetes mellitus). Table 40.6 gives an abbreviated list of disorders to be considered in the differential diagnosis. Pyridoxine supplementation has been reported to improve peripheral polyneuropathy in a group of elderly Japanese dialysis patients; however, this was not a controlled study, and baseline pyridoxal 5'-phosphate levels were not decreased (Moriwaki, 2000).

B. **Mononeuropathies (carpal tunnel syndrome).** Occasionally, prolonged recumbency during the hemodialysis procedure leads to ulnar and peroneal nerve palsies; however, the most common neuropathy is carpal tunnel syndrome, which is due to compression of the median nerve at the wrist where it passes through a narrowed carpal tunnel. Prevalence also increases with years on dialysis and is as high as 73% in patients who have been receiving hemodialysis for 10 years or longer. The pathogenesis appears to be multifactorial. Deposits of β_2 -microglobulin amyloid may compress the median nerve as it passes through the carpal tunnel; however, amyloid is not present in all biopsy specimens. Some patients report exacerbation of symptoms during hemodialysis, perhaps due to a fistula-induced arterial steal phenomenon causing median nerve ischemia. Also, the increase in extracellular fluid volume between dialysis treatments may lead to edema and median nerve compression.

TABLE

40.6

Principal Differential Diagnoses of Uremic Polyneuropathy

Diabetes mellitus
Ethanol abuse
Amyloidosis
Malnutrition
Polyarteritis
Lupus erythematosus
Multiple myeloma
Thiamine deficiency

1. **Symptoms.** Most often, patients complain of numbness, tingling, burning, or a sensation of “pins and needles” in the fingers of the affected hand. The hand may feel stiff or swollen. Although symptoms are usually present in the distribution of the median nerve (over the thumb, index and middle fingers, and radial aspect of the ring finger), patients sometimes complain of sensory disturbance over the entire hand. Aching pain may be referred to the forearm. Symptoms are often worse at night or during hemodialysis, and are exacerbated by activities involving repeated flexion and extension at the wrist. They occur more frequently on the side of the longest functioning vascular access. However, some patients have developed symptoms in an arm that never had been used for a graft or fistula.
2. **Examination.** In early cases, there may be no objective loss of sensation or muscle strength. Symptoms can often be provoked by tapping over the palmar aspect of the carpal tunnel (Tinel sign) or by having the patient hold his or her wrists in a flexed position for 1 minute (Phalen sign). In more advanced cases, perception of light touch, pinprick, temperature, or two-point discrimination may be diminished in the distribution of the median nerve. The abductor pollicis brevis muscle may be weak

and, in longstanding cases, there may be atrophy of the thenar eminence.

3. **Diagnosis.** The differential diagnoses of carpal tunnel syndrome include spondylosis of the lower cervical spine, thoracic outlet syndrome, sensorimotor polyneuropathy or mononeuropathy, and radial arterial steal syndrome in patients with an arteriovenous access. Except in early cases, the diagnosis can usually be established definitively by electromyography (EMG) and nerve conduction velocity studies.
4. **Treatment.** Splinting the affected wrist in a neutral resting position, especially at night and during dialysis treatments, may relieve symptoms temporarily. If splinting is unsuccessful or poorly tolerated, injection of the carpal tunnel with microcrystalline corticosteroid esters will provide about 30% of patients with permanent relief. If symptoms improve inadequately after injection, or if there is significant objective loss of motor or sensory function, surgical decompression of the carpal tunnel yields improvement in more than 90%, but symptoms often recur within 2 years.

IV. FINGER FLEXION CONTRACTURES. β_2 -Microglobulin amyloid can deposit along the flexor tendons of the hands, also. These deposits may make the digital flexor tendons of the hand adhere to one another, creating a subcutaneous soft tissue mass in the palm and irreducible flexion contractures of the fingers. Surgical debridement of amyloid deposits from the flexor tendon sheaths may allow greater finger extension, but these deposits frequently recur within several years.

V. ATLANTO-CERVICAL SPONDYLOPATHY. Progressive neck instability and cord compression due to destructive β_2 -microglobulin-derived amyloidosis has been described in long-term dialysis patients. The condition can be diagnosed by MRI. Early decompression is vital to avoid major disability. Radiographic features include narrowing of the intervertebral disk spaces and erosion of the vertebral end plates without appreciable formation of osteophyte. The lower cervical spine is most often affected, but similar changes may also occur in the dorsal and lumbar spine. Cystic deposits of β_2 -microglobulin amyloid can be seen within the odontoid process and the vertebral bodies of the upper cervical spine. Also, peri-odontoid soft tissue masses of β_2 -microglobulin amyloid, termed “pseudotumors,” may be present. The initial symptom of destructive spondyloarthropathy is pain, typically in the neck when the cervical spine is involved. However, most patients with radiographic abnormalities have no neck pain. Although neurologic compromise occurs infrequently, significant myelopathy has been reported, especially in patients who have received hemodialysis for 20 years or longer. Severe destructive spondyloarthropathy must be differentiated from vertebral osteomyelitis by MRI.

VI. MANAGEMENT OF CHRONIC PAIN. Chronic pain is very challenging to manage in patients receiving maintenance dialysis. Standard hierarchical escalation of analgesic type and choice may not be appropriate. Effective and consistent analgesia without unacceptable side effects is difficult to achieve from the point of view of both drug type choice, and dose and frequency. Intermittent drug removal by hemodialysis provides an additional dimension to consider. Considerable trial and error is often required to achieve this balance, and availability of a specialist pain relief team with relevant experience with dialysis patients is highly desirable.

Access to additional measures such as selective nerve blocks, regional anesthesia, and intra-articular injection may provide optimal pain relief with minimized use of potentially toxic medication with a narrow therapeutic window.

Regular simple analgesics (such as paracetamol [called acetaminophen in the United States]) are the bedrock of chronic pain management. NSAID use may be appropriate in anephric patients, but the risk of sudden loss of residual renal function needs to be carefully considered in patients with some degree of retained renal function. If NSAIDs are used, doses at the lower end of the potential range and lower potency agents such as ibuprofen are preferred. Opiates characteristically accumulate in this setting, and may be markedly dialyzed out, precipitating acute pain relating to hemodialysis sessions. Even the use of weaker agents such as codeine can result in severe obtundation and respiratory arrest. Opiates, however, are often necessary to provide adequate symptom relief. In general, dosing intervals need extending rather than doses limited, slow release preparations should be avoided, and access to “top up” doses may need to be limited. Transdermal release patches can be useful, especially utilizing drugs such as fentanyl, which rely on hepatic disposal. The lowest dose formulation should be utilized initially. Adequate time should be allowed for any of these opioid agents to achieve steady state before escalation of the analgesic algorithm. Co-analgesic drugs such as antidepressants (e.g., tricyclic antidepressants) or anticonvulsants (e.g., gabapentin) are often considered in intractable pain, particularly with a neuropathic element. These can be especially troublesome to utilize without excessive sedation and poor quality of life. Again, doses should be started at the lowest possible level, with very careful dose escalation. Combination of these agents should be avoided if possible. Finally, it is important that nonpharmaceutical strategies in pain management are not neglected. Patients should be closely involved in decision making, and efforts should be made to explain the challenges and manage expectations. Additional interventions such as psychological interventions should be given due consideration.

References and Suggested Readings

- Apostolou T, Gokal R. Neuropathy and quality-of-life in diabetic continuous ambulatory peritoneal dialysis patients. *Perit Dial Int*. 1999;19(suppl 2):S242–S247.
- Arnold R, et al. Effects of hemodiafiltration and high flux hemodialysis on nerve excitability in end-stage kidney disease. *PLoS One*. 2013;8:e59055.
- Benz RL, et al. Potential novel predictors of mortality in end-stage renal disease patients with sleep disorders. *Am J Kidney Dis*. 2000;35:1052–1060.
- Benz RL, Pressman MR, Wu X. Periodic limb movements in sleep revealed by treatment of sleep apnea with continuous positive airway pressure in the advanced chronic kidney disease population. *Clin Nephrol*. 2011;76:470–474.
- Chang JM, et al. Fatal outcome after ingestion of star fruit (*Averrhoa carambola*) in uremic patients. *Am J Kidney Dis*. 2000;35:189–193.
- Davison SN. Pain in hemodialysis patients: prevalence, cause, severity, and management. *Am J Kidney Dis*. 2003;42:1239–1247.
- Dharia SM, Brown LK, Unruh ML. Recognition and treatment of obstructive sleep apnea. *Semin Dial*. 2013;26:273–277.
- Diaz A, Deliz B, Benbadis SR. The use of newer antiepileptic drugs in patients with renal failure.

Expert Rev Neurother. 2012;12:99–105.

- Edmunds ME, Walls J. Pathogenesis of seizures during recombinant human erythropoietin therapy. *Semin Dial.* 1991;4:163.
- Eldehni MT, McIntyre CW. Are there neurological consequences of recurrent intradialytic hypotension? *Semin Dial.* 2012;25:253–256.
- Eldehni MT, Odudu A, McIntyre CW. Randomized clinical trial of dialyzate cooling and effects on brain white matter. *J Am Soc Nephrol.* 2014, in press.
- Elias RM, et al. Relationship of pharyngeal water content and jugular volume with severity of obstructive sleep apnea in renal failure. *Nephrol Dial Transplant.* 2013;28:937–944.
- Forsberg U, et al. Microemboli, developed during haemodialysis, pass the lung barrier and may cause ischaemic lesions in organs such as the brain. *Nephrol Dial Transplant.* 2010;25:2691–2695.
- Glenn CM, et al. Dialysis-associated seizures in children and adolescents. *Pediatr Nephrol.* 1992;6:182.
- Hanly PJ, et al. Daytime sleepiness in patients with CRF: impact of nocturnal hemodialysis. *Am J Kidney Dis.* 2003;41:403–410.
- Hung SC, et al. Thiamine deficiency and unexplained encephalopathy in hemodialysis and peritoneal dialysis patients. *Am J Kidney Dis.* 2001;38:941–947.
- Iftikhar S, Dahbour S, Nauman S. Nonconvulsive status epilepticus: high incidence in dialysis-dependent patients. *Hemodial Int.* 2007;11:392–397.
- Kang HJ, et al. Does carpal tunnel release provide long-term relief in patients with hemodialysis-associated carpal tunnel syndrome? *Clin Orthop Relat Res.* 2012;470:2561–2565.
- Kavanagh D, et al. Restless legs syndrome in patients on dialysis. *Am J Kidney Dis.* 2004;43:763–771.
- Kiley JE. Residual renal and dialyser clearance, EEG slowing, and nerve conduction velocity. *ASAIO J.* 1981;4:1.
- Lass P, et al. Cognitive impairment in patients with renal failure is associated with multiple-infarct dementia. *Clin Nucl Med.* 1999;24:561–565.
- Marsh JT, et al. rHuEPO treatment improves brain and cognitive function of anemic dialysis patients. *Kidney Int.* 1991;39:155.
- McIntyre CW. Recurrent circulatory stress: the dark side of dialysis. *Semin Dial.* 2010;23:449–451.
- McIntyre CW, et al. Circulating endotoxemia: a novel factor in systemic inflammation and cardiovascular disease in chronic kidney disease. *Clin J Am Soc Nephrol.* 2011;6:133–141.
- Molnar MZ, Novak M, Mucsi I. Management of restless legs syndrome in patients on dialysis. *Drugs.* 2006;66:607–624.
- Moriwaki K, et al. Vitamin B6 deficiency in elderly patients on chronic peritoneal dialysis. *Adv Perit Dial.* 2000;16:308–312.
- Nakatani T, et al. Silent cerebral infarction in hemodialysis patients. *Am J Nephrol.* 2003;23:86–90.
- Nicholl DD, et al. Diagnostic value of screening instruments for identifying obstructive sleep apnea in kidney failure. *J Clin Sleep Med.* 2013;9:31–38.
- Novak M, et al. Diagnosis and management of sleep apnea syndrome and restless legs syndrome in dialysis patients. *Semin Dial.* 2006;19:210–216.
- Novak M, et al. Diagnosis and management of insomnia in dialysis patients. *Semin Dial.* 2006;19:25–31.

- Nicholl DD, et al. Diagnostic value of screening instruments for identifying obstructive sleep apnea in kidney failure. *J Clin Sleep Med*. 2013;9:31–38.
- Odudu A, Francis ST, McIntyre CW. MRI for the assessment of organ perfusion in patients with chronic kidney disease. *Curr Opin Nephrol Hypertens*. 2012;21:647–654.
- Okada H, et al. Vitamin B₆ supplementation can improve peripheral neuropathy in patients with chronic renal failure on high-flux hemodialysis and human recombinant erythropoietin. *Nephrol Dial Transplant*. 2000;16:1410–1413.
- Pressman MR, Benz RL. Sleep disordered breathing in ESRD: acute beneficial effects of treatment with nasal continuous positive airway pressure. *Kidney Int*. 1993;43:1134–1139.
- Prohovnik I, et al. Cerebrovascular effects of hemodialysis in chronic kidney disease. *J Cereb Blood Flow Metab*. 2007;27:1861–1869.
- Santoro D, et al. Pain in end-stage renal disease: a frequent and neglected clinical problem. *Clin Nephrol*. 2013;79 (suppl 1):S2–S11.
- Silver SM. Cerebral edema after hemodialysis: the “reverse urea effect” lives. *Int J Artif Organs*. 1998;21:247–250.
- Tang S, et al. Alleviation of sleep apnea in patients with chronic renal failure by nocturnal cyclical-assisted peritoneal dialysis compared with conventional continuous ambulatory peritoneal dialysis. *J Am Soc Nephrol*. 2006;17:2607–2616.
- Tucker KL, et al. High homocysteine and low B vitamin predict cognitive decline in aging men: the Veterans Affairs Normative Aging Study. *Am J Clin Nutr*. 2005;82:627–635.

Tools for Estimating Glomerular Filtration Rate and Daily Creatinine Excretion

II. NORMALIZING GLOMERULAR FILTRATION RATE TO BODY SURFACE AREA *. The proper size denominator to use in adjusting Glomerular Filtration Rate (GFR) to body size is a matter of debate, but traditionally, GFR is normalized in adults to body surface area (BSA)—usually per 1.73 m² of body surface area (the average BSA in early 20th century adults). BSA usually is calculated from an equation proposed by Gehan and George (1970) that depends on height and weight only. It is not dependent on age or gender. A number of Web calculators are available to help with this calculation.

$$BSA = 0.0235 \times W^{0.51456} \times H^{0.422446}$$

Where

W = weight in kg and H = height in cm.

When GFR is normalized to BSA, GFR/1.73 m² in young adult men and women is similar and is in the range of 110–120 mL/min. In children as young as 2 years of age, GFR/1.73m² also remains close to 110–120 mL/min.

Example: How to normalize GFR to 1.73 m² BSA:

Assume raw GFR is 100 mL/min

If BSA = 1.5 m², multiply 100 by 1.73/1.50

$$GFR/1.73m^2 = 115 \text{ mL/min}$$

If BSA = 2.0 m², multiply 100 by 1.73/2.0

$$GFR/1.73m^2 = 86 \text{ mL/min}$$

The example shows two subjects with a GFR of 100 mL/min. One has a BSA of 1.5 m² and the other of 2.0 m². The BSA-normalized GFR is 115 mL/min/1.73 m² in the smaller person, and 86

mL/min/1.73 m² in the larger person.

III. CALCULATING ESTIMATED CREATININE CLEARANCE (eCrCl) USING THE IX EQUATION *. A new equation to predict 24-h creatinine excretion rate was developed and validated by Ix (2011), which was validated in a number of large databases, and is also based on creatinine that was measured using an isotope dilution mass spectrometry (IDMS)-calibrated assay. The new Ix equation is calculated as follows:

When creatinine excretion rate is in mg/24 h and SCr is in mg/dL:

$$eCrCl = [(24\text{-h excretion rate in mg per day})/1440]/(0.01 \times SCr),$$

where:

$$24\text{-h excretion rate in mg} = 880 - 6.2 \times \text{Age} + 12.5 \times (\text{Wt in kg}) + (35 \text{ if Black}) - (380 \text{ if female})$$

or when SCr is measured in mmol/L:

$$eCrCl = [(24\text{-h excretion rate in mmol per day}) / 1440] / (0.001 \times SCr)$$

$$24\text{-h excretion rate in mmol} = 8.84 \times [880 - 6.2 \times \text{Age} + 12.5 \times (\text{Wt in kg}) + (35 \text{ if Black}) - (380 \text{ if female})]$$

Note that the age correction for this new equation by Ix (2011) has a much less steep age correction than Cockcroft and Gault, and the correction for female sex is more severe than the 0.85 term commonly used with Cockcroft and Gault. Weight is included in both the Ix and the Cockcroft and Gault prediction equations for creatinine clearance, since the result of these equations is the “raw” creatinine clearance, uncorrected for BSA.

CKD-EPI EQUATION SET FOR CALCULATING eGFR

Note: Designed for use when SCr is entered as mg/dL.

To convert SCr from mmol/L to mg/dL, multiply by 0.0113

African American Female

If serum creatinine (SCr) ≤ 0.7,

$$eGFR/1.73 \text{ m}^2 = 166 \times (SCr/0.7)^{20.329} \times 0.993^{\text{Age}}$$

If serum creatinine (SCr) > 0.7,

$$eGFR/1.73 \text{ m}^2 = 166 \times (SCr/0.7)^{21.209} \times 0.993^{\text{Age}}$$

African American Male

If serum creatinine (SCr) ≤ 0.9,

$$\text{eGFR}/1.73 \text{ m}^2 = 163 \times (\text{SCr}/0.9)^{20.411} \times 0.993^{\text{Age}}$$

If serum creatinine (SCr) > 0.9,

$$\text{eGFR}/1.73 \text{ m}^2 = 163 \times (\text{SCr}/0.9)^{21.209} \times 0.993^{\text{Age}}$$

White or other race Female

If serum creatinine (SCr) <= 0.7,

$$\text{eGFR}/1.73 \text{ m}^2 = 144 \times (\text{SCr}/0.7)^{20.329} \times 0.993^{\text{Age}}$$

If serum creatinine (SCr) > 0.7,

$$\text{eGFR}/1.73 \text{ m}^2 = 144 \times (\text{SCr}/0.7)^{21.209} \times 0.993^{\text{Age}}$$

White or other race Male

If serum creatinine (SCr) <= 0.9,

$$\text{eGFR}/1.73 \text{ m}^2 = 141 \times (\text{SCr}/0.9)^{20.411} \times 0.993^{\text{Age}}$$

If serum creatinine (SCr) > 0.9,

$$\text{eGFR}/1.73 \text{ m}^2 = 141 \times (\text{SCr}/0.9)^{21.209} \times 0.993^{\text{Age}}$$

IV. EXPECTED 24-HOUR CREATININE EXCRETION RATES (FIG. A.1)

IV. CORCORAN-SALAZAR EQUATION. This equation is a modification of the Cockcroft and Gault equation and can be used to estimate creatinine clearance (not indexed to BSA) in obese persons. (Fig. A.2)

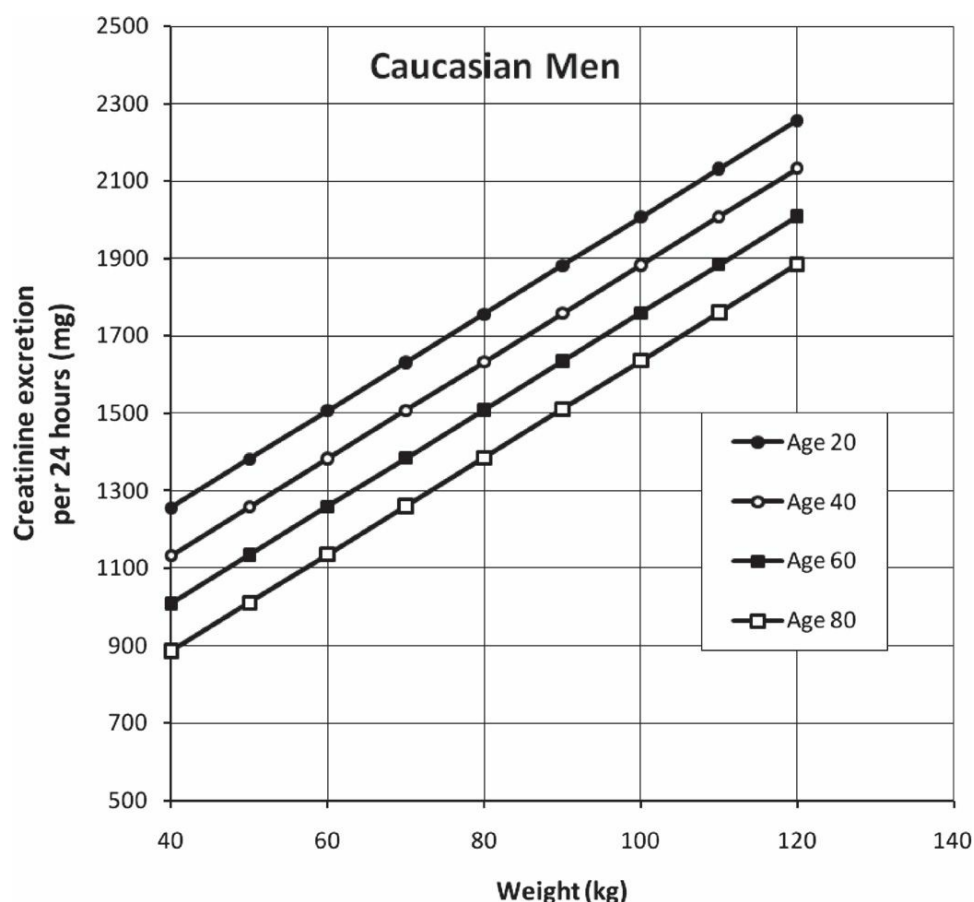

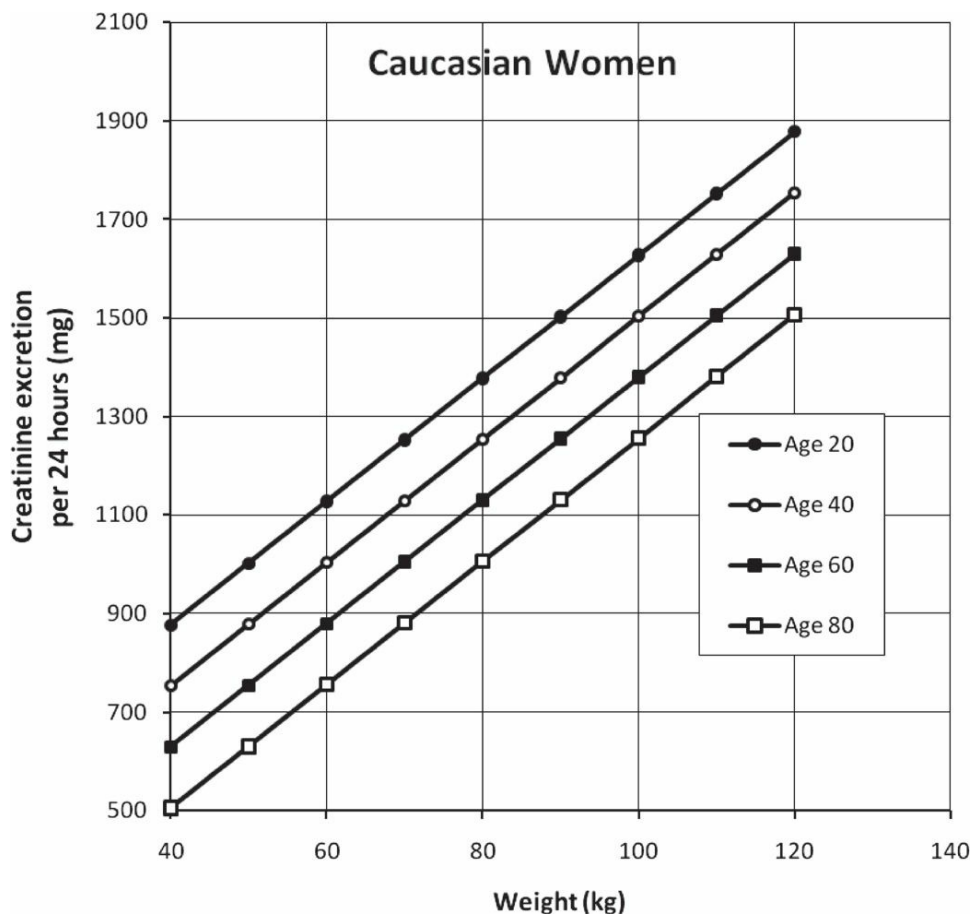

FIGURE A.1. The expected 24-hour creatinine excretion rate in Caucasians according to the new Ix equation (Ix, 2011). For African American males or females, add 35 mg/24h. (Reproduced with permission from Daugirdas JT. *Handbook of Chronic Kidney Disease Management*. Philadelphia, PA: Lippincott Williams & Wilkins; 2011.)

Male:

$$eCrCl = \frac{(137 - \text{age}) \times [(0.285 \times W) + (12.1 \times H^2)]}{51 \times SCr}$$

Female:

$$eCrCl = \frac{(146 - \text{age}) \times [(0.287 \times W) + (9.74 \times H^2)]}{60 \times SCr}$$

where eCrCl = estimated creatinine clearance, W = actual body weight in kg, H = height in meters, and SCr = serum creatinine in mg/dL.

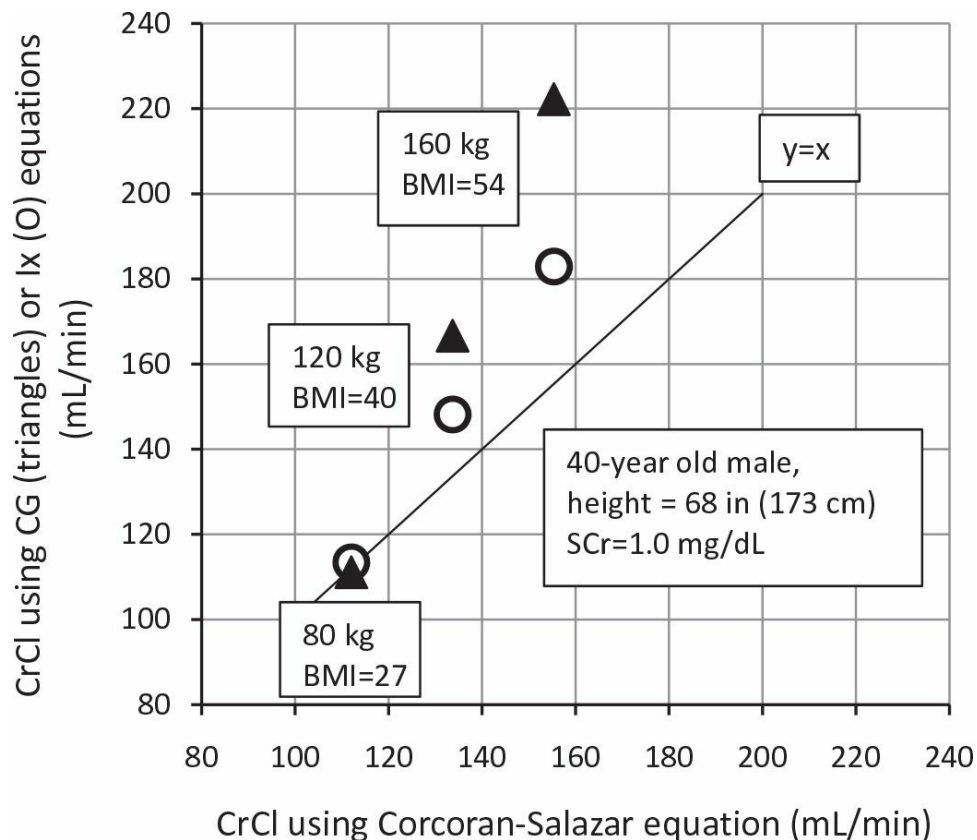

FIGURE A.2. Differences in three CrCl estimating equations in three 40-year-old male subjects all having a SCr of 1.0 mg/dL (88.4 $\mu\text{mol/L}$) and all being of the same height, but weighing 80, 120, or 160 kg. Both the Cockcroft and Gault (CG) and Ix equations tend to overestimate CrCl in markedly obese subjects. (Reproduced with permission from Daugirdas JT. *Handbook of Chronic Kidney Disease Management*. Philadelphia, PA: Lippincott Williams & Wilkins; 2011.)

References and Suggested Reading

- Cockcroft DW, Gault MH. Prediction of creatinine clearance from serum creatinine. *Nephron*. 1976;16:31–41.
- Gehan E, George SL. Estimation of human body surface area from height and weight. *Cancer Chemother Rep*. 1970;54:225–235.
- Ix JH, et al; for the Chronic Kidney Disease Epidemiology Collaboration. Equations to estimate creatinine excretion rate: the CKD Epidemiology Collaboration. *Clin J Am Soc Nephrol*. 2011;6:184–191.
- Levey AS, et al; for the Chronic Kidney Disease Epidemiology Collaboration. A new equation to estimate glomerular filtration rate. *Ann Intern Med*. 2009;150:604–612.
- Salazar DE, Corcoran GB. Predicting creatinine clearance and renal drug clearance in obese patients from estimated fat-free body mass. *Am J Med*. 1988;84:1053–1060.

* Text in I and II cited with permission from MacGregor MS, Methven S. Assessing kidney function. In: Daugirdas JT, ed. *Handbook of Chronic Kidney Disease Management*. Philadelphia, PA: Lippincott Williams & Wilkins; 2011.

Nutritional Tools

I. IDEAL, LEAN, MEDIAN STANDARD, AND ADJUSTED BODY WEIGHTS

A. Ideal body weight equations (kg).

1. Method of Devine (1974):

men: $50 + 2.3$ kg for each inch over 5 feet.

women: $45.5 + 2.3$ kg for each inch over 5 feet.

2. Method of Robinson (1983):

men: $52 + 1.9$ kg for each inch over 5 feet

women: $49 + 1.7$ kg for each inch over 5 feet

B. Adjusted body weight (kg). There are two methods of computing adjusted body weight in widespread use.

1. KDOQI method:

The first, used for protein and calorie recommendations by KDOQI, is:

$$\text{adjBW} = \text{edfreeBW} + (\text{stdBW} - \text{edfreeBW}) \times 0.25,$$

where edfreeBW is the edema-free actual body weight, and stdBW is the median standard weight from Table B.1 (below) and Table B.2.

Table B.1. Median Standard Weights for Men and Women in the United States by Age, Height, and Frame Size (used to compute adjusted body weight).

Height		Median Standard Weight (kg)						Ideal Body Weight (kg) (Robinson)
		Age 25–54			Age 55–74			
In	cm	Frame Size ^a						
		S	M	L	S	M	L	
Men								
62	157	64	68	82	61	68	77	55.8
63	160	61	71	83	62	70	80	57.7
64	163	66	71	84	63	71	77	59.6
65	165	66	74	84	70	72	79	61.5
66	168	67	75	84	68	74	80	63.4
67	170	71	77	84	69	78	85	65.3
68	173	71	78	86	70	78	83	67.2
69	175	74	78	89	75	77	84	69.1
70	178	75	81	87	76	80	87	71
71	180	76	81	91	69	84	84	72.9
72	183	74	84	91	76	81	90	74.8
73	185	79	85	93	78	88	88	76.7
74	188	80	88	92	77	95	89	78.6
Women								
58	147	52	63	86	54	57	78	45.6
59	150	53	66	78	55	62	78	47.3
60	152	53	60	87	54	62	78	49
61	155	54	61	81	56	64	79	50.7
62	157	55	61	81	58	64	82	52.4
63	160	55	62	83	58	65	80	54.1
64	163	57	62	79	60	66	77	55.8
65	165	60	63	81	60	67	80	57.5
66	168	58	63	75	68	66	82	59.2
67	170	59	65	80	61	72	80	60.9
68	173	62	67	76	61	70	79	62.6
69	175	63	68	79	62	72	85	64.3
70	178	64	70	76	63	73	85	66

^aFrame size as defined in Table B.2.

Data for median standard weight derived from the combined NHANES I and NHANES II datasets (Frisancho, 1984).

Ideal body weight computed according to Robinson (1983).

(Reproduced with permission from Daugirdas JT. *Handbook of Chronic Kidney Disease Management*. Philadelphia, PA: Lippincott Williams & Wilkins; 2011.)

■■■■■■■ 2. ■■Based on ideal body weight: Another version, commonly used in drug dosing, is:

Adjusted body weight = $IBW \times 1.043$ (edfreeBW 2 IBW),

where IBW = ideal body weight calculated according to Devine or Robinson as described above.

Table B.2. Frame Size as Determined by Elbow Breadth in cm.

Age (y)	Frame Size		
	Small	Medium	Large
Men			
18–24	≤6.6	>6.6 and <7.7	≥7.7
25–34	≤6.7	>6.7 and <7.9	≥7.9
35–44	≤6.7	>6.7 and <8.0	≥8.0
45–54	≤6.7	>6.7 and <8.1	≥8.1
55–64	≤6.7	>6.7 and <8.1	≥8.1
65–74	≤6.7	>6.7 and <8.1	≥8.1
Women			
18–24	≤5.6	>5.6 and <6.5	≥6.5
25–34	≤5.7	>5.7 and <6.8	≥6.8
35–44	≤5.7	>5.7 and <7.1	≥7.1
45–54	≤5.7	>5.7 and <7.2	≥7.2
55–64	≤5.8	>5.8 and <7.2	≥7.2
65–74	≤5.8	>5.8 and <7.2	≥7.2

Derived from the U.S. population in the NHANES 1 and NHANES 2 datasets.

Data from Frisancho (1984).

(Reproduced with permission from Daugirdas JT. *Handbook of Chronic Kidney Disease Management*. Philadelphia, PA: Lippincott Williams & Wilkins; 2011.)

C. Lean body weight equations (kg):

1. Janmahasatian (2005):

men: $9270 \times \text{wt}(\text{kg}) / (6680 + 216 \times \text{BMI})$

women: $9270 \times \text{wt}(\text{kg}) / (8780 + 244 \times \text{BMI})$

III. BODY SURFACE AREA EQUATIONS.

SA = surface area, **W** = postdialysis weight in kg, **H** = height in cm.

A. Gehan and George (1970). This can be used in all patients, but should especially be used when age <18 years.

$$SA = 0.0235 \times W^{0.51456} \times H^{0.422446}$$

■■■■ B. Dubois and Dubois (1916). (not as good as Gehan and George in children or in obese adults).

$$SA = 0.007184 \times W^{0.425} \times H^{0.725}$$

■■■■ TOTAL BODY WATER ANTHROPOMETRIC EQUATIONS. (FIGS. B.1 AND B.2)

■■■■ TBW = total body water, W = postdialysis weight in kg, H = height in cm.

■■■■ A. Watson (1980).

$$■■■■■■ TBW_{\text{male}} = 2.447 - 0.09516 \times \text{Age} + 0.1074 \times H + 0.3362 \times W$$

$$■■■■■■ TBW_{\text{female}} = 0 - 2.097 + 0.1069 \times H + 0.2466 \times W$$

■■■■ B. Morgenstern (2006).

■■■■■■ Use in patients <19 years of age.

$$■■■■■■ HW = H \times W$$

$$■■■■■■ TBW_{\text{male}} = 0.10 \times (HW)^{0.68} - 0.37 \times W$$

$$■■■■■■ TBW_{\text{female}} = 0.14 \times (HW)^{0.64} - 0.35 \times W$$

■■■■ C. Hume and Weyers (1971):

$$■■■■■■ TBW_{\text{male}} = (0.194786 \times H) + (0.296785 \times W) - 14.012934$$

$$■■■■■■ TBW_{\text{female}} = (0.344547 \times H) + (0.183809 \times W) - 35.270121$$

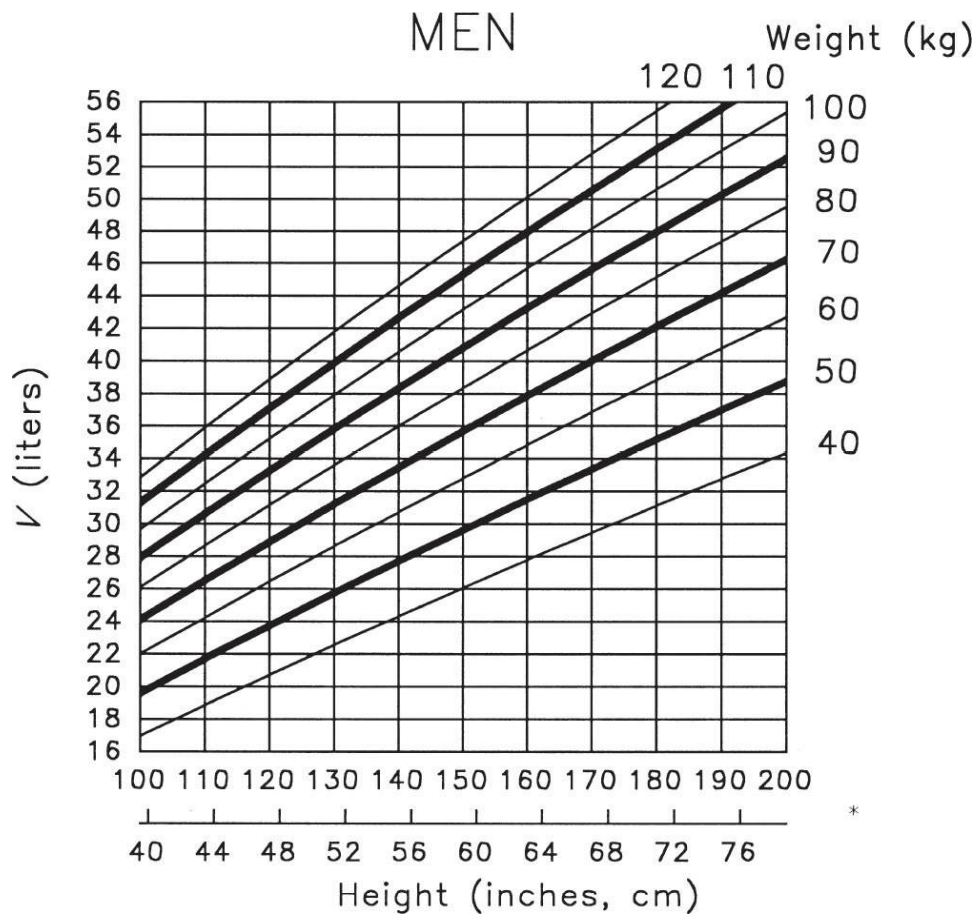

FIGURE B.1. Estimated total body water urea (V) in males as a function of weight and height. To use, find the height on the horizontal axis, rise until the appropriate weight line has been reached, and read V off the vertical axis. For urea modeling, use the postdialysis weight. The modeled V is usually 90% of the anthropometric V . The values are calculated from the Hume and Weyer equation described above. (Reprinted from Daugirdas JT, Depner TA. A nomogram approach to hemodialysis urea modeling. *Am J Kidney Dis.* 1994;23:33–40, with permission from Elsevier.)

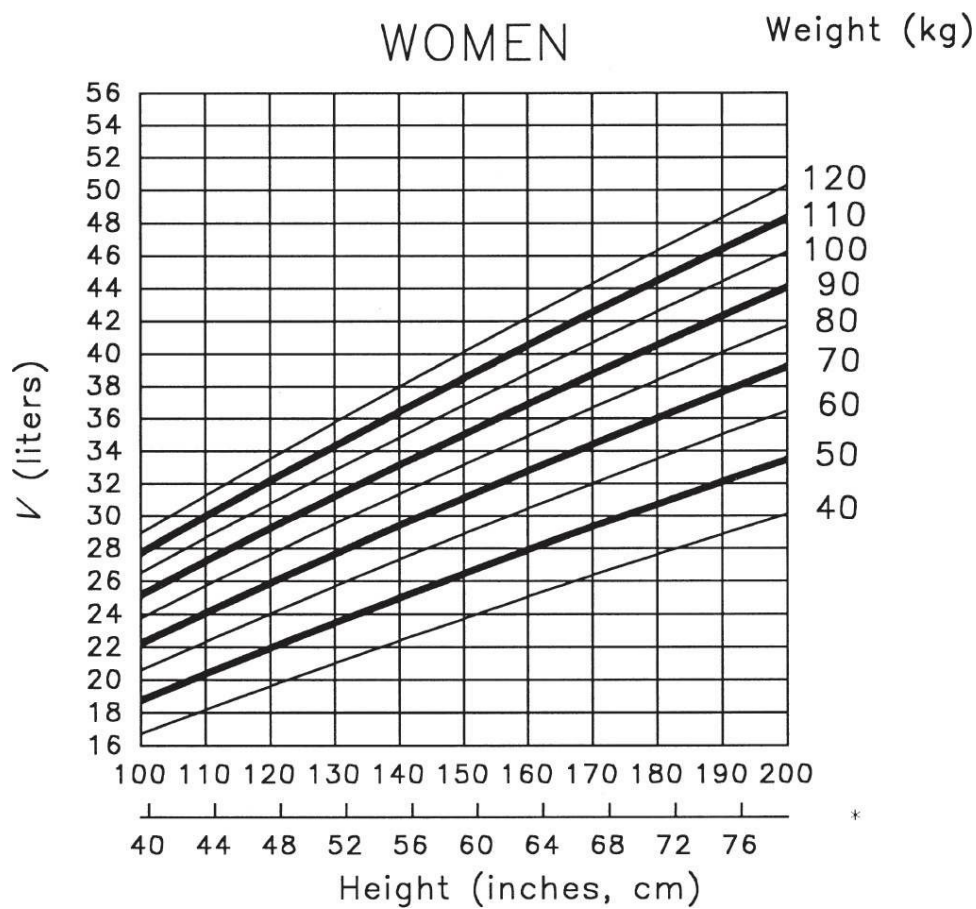

FIGURE B.2. Estimated total body water urea (V) in females as a function of height and weight. To use, find the height on the horizontal axis, rise until the appropriate weight line has been reached, and read V off the vertical axis. For urea modeling, use the postdialysis weight. The modeled V usually is 90% of the anthropometric V . The values are calculated from the Hume and Weyer equation described above. (Reprinted from Daugirdas JT, Depner TA. A nomogram approach to hemodialysis urea modeling. *Am J Kidney Dis.* 1994;23:33–40, with permission from Elsevier.)

IV. SELECTED DIET COMPOSITION TABLES.

III A. Potassium

Table B.3 to Table B.8

III A. Phosphorus

Table B.9 to B.11

Table B.3. Potassium Content of Salts, Salt Substitutes, and Baking Powders

Product	Sodium (mg per $\frac{1}{4}$ teaspoon)	Potassium (mg per $\frac{1}{4}$ teaspoon)
No salt	0	650

Morton's Salt Substitute	0	610
Adolph Salt Substitute	0	600
McCormick's Unseasoned Salt Substitute	0	585
Diamond Crystal Salt Substitute	0	550
Co-Salt	0	495
Morton's Lite Salt	245	375
Table salt	590	0
Sea salt	560	0
Salt sense	390	0
Lessalt	310	170
Baking soda	250–300	0
Baking powder ^a	80	0
Monosodium glutamate	125	0

^aThere are many different types of baking powders, and the sodium content varies widely. (Reproduced with permission from Daugirdas JT. *Handbook of Chronic Kidney Disease Management*. Philadelphia, PA: Lippincott Williams & Wilkins; 2011.)

Table B.4. Potassium Content of Foods Considered to be High in Potassium

Food	Typical Serving	Potassium	Content
Banana	1 small, 6"–7" long	360 mg	9.3 mmol
Cantaloupe	1 cup diced	420 mg	11 mmol
Orange juice	½ cup from frozen, reconstituted with water	240 mg	6.1 mmol
Prunes	5, dried, uncooked	350 mg	8.9 mmol
Avocado	Raw, ½ cup sliced	350 mg	9.0 mmol
Potato	Baked, 2¼" to 3" diameter, peel eaten	920 mg	23 mmol
Potato	Baked, 2¼" to 3" diameter, peel not eaten	510 mg	13 mmol
Spinach	1 cup cooked	840 mg	21 mmol
Brussels sprouts	1 cup cooked	490 mg	13 mmol
Broccoli	1 cup cooked flowerets	290 mg	7.4 mmol
Milk	1 cup, whole milk	350 mg	8.9 mmol
Yogurt	Fruit variety, from low-fat milk, 1 cup	440 mg	11 mmol
Dried beans	1 cup cooked, most varieties	880 mg	23 mmol

(Reproduced with permission from Daugirdas JT. *Handbook of Chronic Kidney Disease Management*. Philadelphia, PA: Lippincott Williams & Wilkins; 2011.)

Table B.5. Fruits: Potassium Content per 250 g Serving (about 1 cup)

mg	125–249	250–374	375–499	500–624	>625
mmol	3.2–6.39	6.4–9.59	9.6–12.79	12.8–15.99	>16.0
Listed from lower to higher within each column range	Blueberries, frozen or canned	Apples, raw	Strawberries, raw	Gooseberries, raw	Melons, cantaloupe, raw
	Apples or pears, canned	Pineapple, raw	Plums, canned or raw	Pummelo, prickly pear, raw	Guavas, raw
	Tangerines, canned	Rhubarb, frozen	Mangos, raw	Melons, honeydew, raw	Rhubarb, raw
	Fruit salad	Pears, rose apples, raw	Blackberries, raw	Figs, raw	Guavas, raw
	Cranberries, raw	Cherries, frozen or canned	Litchis, raw	Papayas, raw	Kiwi fruit, raw
		Apricots or peaches, canned	Cherries, raw	Apricots, raw	Currants, raw
	Lemons, raw	Oranges, raw		Passion fruit, raw	

Grapefruit, raw	Melons, casaba, raw	Bananas, raw
	Peaches, raw	Avocados, raw
	Grapes, raw	Plantains, cooked
	Crabapples, quinces, raw	Breadfruit, raw
		Tamarinds, raw
		Persimmons, raw
		Raisins
		Dried currants, peaches, apricots

From Nutritiondata.com, which is based on the USDA National Nutrient Database for Standard Reference, with permission.

Table B.6. Potassium in Fruit and Vegetable Juice

Fruit Source	mg per cup (~240 mL)	mmol per 240 mL
Cranberry	195	5.0
Apple	275	7.0
Grapefruit	400	10
Orange	465	12
Tomato	500	13

(Reproduced with permission from Daugirdas JT. *Handbook of Chronic Kidney Disease Management*. Philadelphia, PA: Lippincott Williams & Wilkins; 2011.)

Table B.7. Potassium Content of Vegetables

Lower Potassium Content	Higher Potassium Content
Asparagus	Artichokes
Beans (green beans or wax beans)	Bamboo shoots
Cabbage	Beans and lentils
Carrots	Beets
Cauliflower	Broccoli, Brussels sprouts
Celery	Chinese cabbage, greens
Corn	Kohlrabi
Cucumber	Mushrooms

Eggplant	Parsnips
Kale	Potatoes (white or sweet)
Lettuce	Pumpkin
Mixed vegetables	Rutabaga
Okra	Spinach
Onions	Squash (Hubbard)
Peas	Tomatoes
Peppers	
Radish	
Rhubarb	
Squash (summer)	
Watercress	
Water chestnuts	
Zucchini	

(Modified from the U.S. National Kidney Foundation Web site. Reproduced with permission from Daugirdas JT. *Handbook of Chronic Kidney Disease Management*. Philadelphia, PA: Lippincott Williams & Wilkins; 2011.)

Table B.8. Potassium Content of Foods Other than Fruits or Vegetables

Lower Potassium Content	Higher Potassium Content
Rice	Whole-grain pasta and breads
Noodles	Cereals containing bran
Pasta	Milk, yogurt, cheese
Refined breads	Nuts and seeds
Pies without chocolate or high-potassium fruit	Some salt-free broths and soup stocks
Cookies without nuts or chocolate	Salt substitutes

(Reproduced with permission from Daugirdas JT. *Handbook of Chronic Kidney Disease Management*. Philadelphia, PA: Lippincott Williams & Wilkins; 2011.)

Table B.9. Milligrams of Phosphorus per g Protein Content of Common Protein-Rich Foods

Protein Range (mg phosphate per g)	Food Source and Value
<5.0	Egg white (1.4)
	Cod (6.0)
5.1–7.0	Chicken, dark meat (6.5)
	Shrimp (6.5)
	Turkey (7.1)
	Beef, tenderloin (8.3)
	Rabbit, wild (7.3)
	Beef, bottom round (8.5)
	Chicken, white meat (7.4)
	Pork (8.9)

7.1–10.0	Goat (7.4) Lobster (9.0) Lamb, leg (7.4) Venison, loin steak (9.1) Crab, Dungeness (7.8) Tuna, canned (9.2) Ground beef, 95% lean (7.8) Ground beef, 80% lean (9.6) Beef, brisket (8.1) Haddock (10.0) Tuna, yellow fin (8.2) Halibut (10.7)
10.1–11.9	Cottage cheese, 2% low fat (10.9) Salmon, farm raised (11.4) Catfish (13.0) Peanut butter, crunchy (13.0)
12–14.9	Egg, whole (13.2) Crab, Alaska King (14.5) Peanut butter, smooth (14.5) Peanuts (15.0) Salmon, canned (15.8)
15.0–20.0	Pinto beans (16.3) Soy nuts (16.4) Liver, beef, and chicken (17.5) Soy milk, regular, not enriched (17.9) Cheddar cheese (20.6) Swiss cheese (21.3)
>20.0	Almonds (25.3) Milk, 2% low fat (27.6) American cheese (30.7) Cashews (32.3)

(Data from: Pennington JAT, Douglas JS, eds. *Bowes & Church Food Values of Portions Commonly Used*. 18th ed. Baltimore, MD: Lippincott Williams & Wilkins; 2005.

Reproduced with permission from Daugirdas JT. *Handbook of Chronic Kidney Disease Management*. Philadelphia, PA: Lippincott Williams & Wilkins; 2011.)

Table B.10. Foods Containing High Amounts of Organic or Inorganic Phosphate

Organic Phosphate	Inorganic Phosphate
Dairy products	<i>Beverages</i> Colas, “Pepper”-style sodas, some fruit punches, some flavored waters, plastic bottled iced teas, plastic bottled fruit beverages, some energy drinks, premixed diet shakes, bottled coffee beverages, liquid nondairy creamers
Nuts and seeds	
Chocolate	<i>Processed Meats</i>

Meat	“Enhanced” meat products, self-basting frozen turkeys, sausages, luncheon meats, restructured meats (chicken nuggets), hot dogs
Fish	<i>Diary Products with Additives</i>
Eggs	Processed cheese products, half and half, evaporated milk, pudding, whipped topping
Legumes (soy, peanuts, peas, beans, lentils)	<i>Calcium Phosphate–Fortified Products</i>
Whole-grain cereals	Juices, breakfast cereals, breakfast bars, protein bars, “instant” hot cereals, mineral supplements <i>Refrigerated and Frozen Bakery Products</i> Biscuits, crescent rolls, rolls, cake, Danish, cheese cake <i>Calcium or Magnesium Phosphate in Vitamins or Osteoporosis Mineral Supplements</i>

(Data from Murphy-Gutekunst L. Hidden phosphorus in popular beverages: Part 1. *J Ren Nutr.* 2005;15:e1–e6. Murphy-Gutekunst L, Barnes K. Hidden phosphorus at breakfast: Part 2. *J Ren Nutr.* 2005;15:e1–e6. Reproduced with permission from Daugirdas JT. *Handbook of Chronic Kidney Disease Management.* Philadelphia, PA: Lippincott Williams & Wilkins; 2011.)

Table B-11. Specialty Products and Supplements

Company	Product and Product Analysis
Ross Nutrition www.abbottnutrition.com	Suplena Per 8 ounce can: 425 calories 185 mg sodium 10.6 g protein 165 mg phosphorus 265 mg potassium
Nestle Nutrition www.nestlenutritionstore.com	Resource Benecalorie Per 1.5 oz. carton: 330 calories 15 mg sodium 7 g protein 55 mg phosphorus 0 mg potassium
Ener-G foods www.ener-g.com	Whole line of low-protein breads, pasta, flour, cereals, and egg products Available in stores and on Web site
Med Diet, Inc www.med-diet.com	Offers low-protein bread, cookies, baking mixes, and condiments Available online only
Maddy’s low-protein store www.dietforlife.com	Whole line of low-protein snacks, cereals, and bakery products Available online only
Cambrooke Foods www.cambrookefoods.com	Offers low-protein breads, pasta products, meat products, and cheese products Available online only

(Reproduced with permission from Daugirdas JT. *Handbook of Chronic Kidney Disease Management*. Philadelphia, PA: Lippincott Williams & Wilkins; 2011.)

Urea Kinetic Modeling

II. Estimating dialyzer blood water clearance from K_0A , Q_b , and Q_d

Step 1: Calculate in vivo K_0A from industry-reported in vitro K_0A

$$K_0A_{\text{invivo}} = 0.574 \times K_0A_{\text{invitro}}$$

Step 2: Adjust K_0A_{invivo} downward if dialysate flow rate < 500 mL/min (because of poor penetration of dialysis solution in the fiber bundle). We no longer recommend making this adjustment for $Q_d > 500$ mL/min, as manufacturers have improved penetration of dialysate into the fiber bundle at high dialysis solution flow rates. When $Q_d < 500$ mL/min, the following adjustment can be used, which lowers the effective in vivo K_0A . However, when $Q_d < 350$ mL/min, K_0A can decrease very substantially; there is little data to help quantify the adjustment needed. The minor adjustment in the equation below does not fully account for the reduction in K_0A when very low Q_d values are used.

$$K_0A_{\text{invivo}} = K_0A_{\text{invivo}} \times (1 + 0.0549 \times (Q_d - 500)/300);$$

Step 3: Compute diffusive blood water clearance (K_{difw}) from estimated in vivo K_0A , Q_b , and Q_d .

$$Z = \exp [K_0A / (0.86 \times Q_b) \times (1 - 0.86 \times Q_b / Q_d)]$$

$$K_{\text{difw}} = 0.86 \times Q_b \times (Z - 1) / (Z - 0.86 \times Q_b / Q_d)$$

Step 4: Add convective clearance to diffusive clearance to calculate dialyzer clearance (K_d).

$$Q_f = W_{\text{loss}} \times 1000 / TD_{\text{min}}$$

$$K_d = [1.2 \times Q_f / (0.86 \times Q_b)] \times K_{\text{difw}} + Q_f$$

In step 4, the sign of the Q_f term in mL/min is positive; i.e., > 0 .

The values shown in Figure 3.6 were derived using the above equations. An ultrafiltration (Q_f) value of 11.7 mL/min (about 2.8 L weight loss for a 4-hour treatment) was used. We assumed

that the whole blood flow rate on the horizontal axis of Figure 3.6 was the true whole blood flow rate, and that it is not diminished by tubing collapse due to flattening of the pump segment at high prepump pressures.

III. How to calculate the standard Kt/V (std Kt/V).

||||| This can be done using a urea kinetic program such as Solute Solver, which is available free of charge to not-for-profit organizations (Daugirdas, 2012) or with a Web-based calculator on HDCN (see Web references). A simplified approach using estimating equations can also be done as follows:

||||Step 1: Compute sp Kt/V .

||||| This can be done by inputting the urea reduction ratio (URR), weight change, and dialysis session length into the Daugirdas Kt/V estimating equation described in Chapter 3, or by using the nomogram derived from this equation shown in Figure 3.14. When using other than 3/week schedules, one should ideally modify the urea generation coefficient of the Daugirdas Kt/V estimating equation to adjust for frequency and interdialytic interval (Daugirdas, 2013). Alternatively, sp Kt/V can be calculated using a urea modeling program.

||||Step 2: Compute e Kt/V .

||||| This can be done using the modified Tattersall equation as described in Chapter 3.

||||Step 3: Use the Leypoldt equation to get a fixed-volume standard Kt/V (S).

$$S = \frac{10080 \frac{1 - e^{-eKt/V}}{t}}{\frac{1 - e^{-eKt/V}}{eKt/V} + \frac{10080}{N \times t} - 1}$$

||||| S = fixed volume std Kt/V ; e Kt/V = equilibrated Kt/V ; N = sessions per week; t = session length in minutes.

||||Step 4: Adjust the standard Kt/V fixed volume value (S) for volume removal using the FHN equation (Daugirdas, 2010c).

$$stdKt/V = S / [1 - (0.74/F) \times UF_week / V],$$

|||| where S is the simplified, fixed volume value from the Leypoldt equation, F is the frequency (sessions per week), UF_week is the weekly fluid gain between dialyses in liters, and V is the estimated urea volume, which can be entered as 90% of the Watson volume.

||||| Example: S = 2.0, F = × times per week, UF_week = 10 L, V = 35 L.

$$stdKt/V = 2.0 / [1 - (0.74/3.0) \times 10/35]$$

$$= 2.0 / (1 - 0.247 \times 0.286)$$

$$= 2.0 / (1 - 0.070)$$

$$= 2.0 / 0.93 = 2.15$$

■■■■■ Thus, after adjusting for volume, the stdKt/V is 2.15 instead of 2.0. The old 2.0 minimum value of stdKt/V suggested by the KDOQI 2006 guidelines should therefore be 2.15 when the volume-adjusted stdKt/V is used; the latter should be used as it corresponds very closely to the stdKt/V calculated using formal urea kinetic modeling (Daugirdas, 2010c).

■■■■ How to calculate surface-area normalized stdKt/V .

■■■■ **Step 1:** Calculate the median V/S ratio for your region's population, where V = estimated total body water using the Watson equation, and S = estimated body surface area using the Gehan and George equation or the Dubois equation (these equations are listed in Appendix B). Call this variable "M". For the U.S. population, this value is close to 20.0 for adults when V is computed using Watson and S using Dubois (Ramirez, 2012). The median ratio is close to 17.5 in children when V is computed using Morgenstern and S is computed using the Gehan George equation (Daugirdas, 2010b).

■■■■ M = median ratio of V/S

■■■■ **Step 2:** Calculate the adjustment factor for the patient in question. Compute V and S using the same equations that were used to calculate "M." The adjustment factor is simply (V/S) / M.

■■■■ $\text{SAN-stdKt}/V = (V/S) / M \times \text{stdKt}/V$

■■■■■ For more information see Ramirez (2010). The target SAN- stdKt/V is opinion based. Probably a value of at least 2.2 is appropriate. Values of 2.5 and 2.4, respectively, were the mean doses given to women in the high-dose arm of the HEMO trial, and to men in the conventional dose group (Daugirdas, 2010a).

References and Suggested Readings

Daugirdas JT, et al. Solute-solver: a Web-based tool for modeling urea kinetics for a broad range of hemodialysis schedules in multiple patients. *Am J Kidney Dis.* 2009;54:798–809.

Daugirdas JT, et al. Can rescaling dose of dialysis to body surface area in the HEMO study explain the different responses to dose in women versus men? *Clin J Am Soc Nephrol.* 2010a;5:1628–1636.

Daugirdas JT, et al. Dose of dialysis based on body surface area is markedly less in younger children than in older adolescents. *Clin J Am Soc Nephrol.* 2010b;5:821–827.

Daugirdas JT, et al; Frequent Hemodialysis Network Trial Group. Standard Kt/Vurea: a method of calculation that includes effects of fluid removal and residual kidney clearance. *Kidney Int.* 2010c;77:637–644.

Daugirdas JT, et al; FHN Trial Group. Improved equation for estimating single-pool Kt/V at higher dialysis frequencies. *Nephrol Dial Transpl.* 2013;28:2156–2160.

Daugirdas JT. Dialysis dosing for chronic hemodialysis: beyond Kt/V. *Semin Dial.* 2014;27:98–107.

Depner TA, et al. Dialyzer performance in the HEMO study: in vivo K₀A and true blood flow

determined from a model of cross-dialyzer urea extraction. *ASAIO J.* 2004;50:85–93.

Leyboldt JK, et al. Predicting treatment dose for novel therapies using urea standard Kt/V. *Semin Dial.* 2004;17:142–145.

Ramirez SP, et al. Dialysis dose scaled to body surface area and size-adjusted, sex-specific patient mortality. *Clin J Am Soc Nephrol.* 2012;7:1977–1987.

Web References

Solute solver: <http://www.ureaKinetics.org> (suggest that users start with the “lite” version).

For an stdKt/V calculator see <http://www.hdcn.com/calcf/ley.htm>. Accessed 7 July 2014.

Molecular Weights and Conversion Tables

II. TABLE D.1

Table D.1. Molecular Weights and Conversion Tables

Molecular Weights (MW) of Selected Substances	
Substance	MW
Acetylsalicylic acid (aspirin)	180
Albumin	68,000
β_2 -microglobulin	11,600
Cholesterol	386
Creatinine	113
Dextrose (glucose monohydrate)	198
Ethanol	46
Ethylene glycol	62
Glucose	180
Hemoglobin	68,800
Isopropyl alcohol (isopropanol)	60
Light chains	23,000
Lithium	7
Methanol	32
Myoglobin	17,800
Parathyroid hormone	9,500
Phenobarbital	232
Theophylline	180
Triglycerides	886
Urea	60
“Urea nitrogen” (blood urea nitrogen [BUN] or serum	

urea nitrogen [SUN])	28
Vancomycin	1,486
Vitamin B ₁₂	1,355
Vitamin D ₃ (25-D ₃)	402

III. CONVERTING BETWEEN WEIGHT, VALENCY, AND MOLARITY

III A. Number of milligrams in 1 mEq or 1 mmol of substance

Substance	1 mEq	1 mmol
Na ⁺	23	23
K ⁺	39	39
Ca ²⁺	20	40
Mg ²⁺	12	24
Li ⁺	7	7
HCO ₃ ⁻	61	61
Cl ⁻	35.5	35.5
N (nitrogen)		14
P (phosphorus)		31
C (carbon)		12

III B. Changing milligrams to milliequivalents or millimoles

1. Sodium, potassium, chloride, bicarbonate

1 g NaCl	= 1,000 mg / (23 + 35.5) mg
	= 17 mEq or mmol of Na ⁺
1 g Na ⁺	= 1,000 mg / 23 mg
	= 43 mEq or mmol of Na ⁺
1 g KCl	= 1,000 mg / 74.5 mg
	= 14 mEq or mmol of K ⁺
1 g K ⁺	= 1,000 mg / 39 mg

	= 26 mEq or mmol of K^+
1 g $NaHCO_3$	= 1,000 mg/84 mg
	= 12 mEq or mmol of Na^+
	= 12 mEq or mmol of HCO_3^-

2. Calcium (mg/dL to mmol/L conversion)

	= 10 mg/dL
	= 100 mg/L
	= 100/20 mmol/L, since 20 mg = 1 mEq
	= 5 mEq/L
	= 5/2 mmol/L since 2 mEq = 1 mmol
	= 2.5 mmol/L

3. Magnesium (mg/dL to mmol/L conversion)

	= 2.4 mg/dL
	= 24 mg/L
	= 24/12 mEq/L, since 12 mg = 1 mEq
	= 2 mEq/L
	= 2/2 mmol/L, since 2 mEq = 1 mmol
	= 1 mmol/L

4. Phosphorus (P) (mg/dL to mmol/L conversion)

	= 2.5 to 4 mg/dL
	= 25 to 40 mg/L
	= (25/31 to 40/31) mmol/L, since 1 mmol of P = 31 mg
	= 0.8 to 1.3 mmol/L

Because P values when expressed in mEq/L change with alterations in pH, the mEq/L unit is not ordinarily used in clinical practice.

NOTE: Page numbers followed by *f* indicate figure; those followed by *t* indicate table.

A

Abacavir, 641*t*, 659

 plus lamivudine, 660

 plus zidovudine, 660

Abdominal catheters, 427

Abdominal ultrasonography, for gynecologic neoplasms, 751

Abnormal uterine bleeding, 745–748

Acarbose, for diabetes, 567

Access recirculation, 55–56, 75*f*

Acetaminophen, 225, 374, 774

Acidosis

 in ESKD, 710–711

 in infants and children, 710–711

 metabolic, 8, 19, 177, 277, 280, 288, 373, 374, 375, 376, 377, 378, 379, 380, 384, 454, 456, 524–525, 535, 547, 551, 571, 693, 710

 respiratory, 177

 severe, 177

Activated clotting time (ACT), 255

Activated partial thromboplastin time (APTT), 254

Acute formaldehyde reactions, 245

Acute kidney injury (AKI)

 peritoneal dialysis for, 451–462

 advantages and disadvantages of, 452*t*

 complications of, 460–462

 indications, 451–453

 infrastructure of, 462

 prescribing and dosing of, 456–460

 sample orders, 457*t*

 technical aspects of, 453–456

 problems with estimated clearances in, 7

Acute lung injury, 300–301

Acute obtundation, 758–759, 761*f*
Acyclovir, 294*t*, 640*t*
 for herpes/varicella-zoster infections, 657, 658
Adefovir, 641*t*
 for hepatitis B infection, 624
Adjusted body weight, 783, 783–784*t*, 785*t*
 based on ideal body weight, 784
Adjuvant therapies and exercise, 552–553
Adolescents, on dialysis, 28
Adrenergic modulators, for hypertension, 587–588*t*
 β -, α/β -, and α -adrenergic blockers, for hypertension, 585
Advanced glycosylation end products (AGEs), diet and, 558
Adynamic bone disease, 680
Air embolism, 233
Albumin. *See also* Serum albumin
 dialyzer reuse and, 248
 predialysis, 211
 as replacement solution, 343*t*, 344–345
Aldosterone blocking agents, 726–727
Alkalemia, 373
Alkalosis
 common causes of, 176
 metabolic, dangers of, 176
 predialysis respiratory, 176
 respiratory, 176
Allen test, 102, 103*t*
Allient system, 365
Alogliptin, for diabetes, 570
Alprazolam, for anxiety and behavior disorders, 531
Alteplase protocols, 165
Aluminum
 intoxication, 607–608, 756–757
 sleep disorders and, 756–757
 toxicity, 689–690
Aluminum carbonate, 676
Aluminum hydroxide, 676
Amantadine, 640*t*
 for drug-induced extrapyramidal syndromes, 657
 for influenza A and B, 657
 for parkinsonism, 657
American College of Cardiology (ACC), lipid guidelines, 10–11
American Heart Association (AHA), lipid guidelines, 10–11

American Nephrology Nurses Association, "Save the Vein" project, 101

Amikacin, 294*t*, 496, 635*t*, 652, 653

concentration in lock solutions, 163*t*

for peritonitis, 498*t*

Amino acids, 480–481, 550–551

Aminoglycosides, 635*t*, 650–651

amikacin, 294*t*, 498*t*, 635*t*, 652

gentamicin, 294*t*, 498*t*, 503, 635*t*, 651–652

monitoring levels of, 652–653

neomycin, 635*t*

netilmicin, 498*t*

for peritonitis, 498*t*, 499

streptomycin, 635*t*, 652

tobramycin, 295*t*, 498*t*, 499*t*, 635*t*, 651–652

Aminotransferase values, 212

Amiodarone

for acute arrhythmias, 733

for chronic arrhythmias, 733

use in ICU, 297*t*

for ventricular arrhythmias and ectopy, 734

Amoxicillin, 507, 617, 630*t*

plus clavulanate, 629, 640

for exit-site and tunnel infections, 509*t*

for peritonitis, 498*t*

Amphotericin B, 369, 644*t*, 645*t*, 660, 661

for candida infection, 163*t*

concentration in lock solutions, 163*t*

for peritonitis, 498*t*, 505

Ampicillin, 294*t*, 502, 507, 617, 629, 630*t*

concentration in lock solutions, 163*t*

for peritonitis, 498*t*

for urinary tract infection, 619

Amylase, peritonitis and, 501

Anemia, 13, 742–743

ascorbic acid and, 609

bleeding and, 605–606

cardiovascular disease, 721

carnitine and, 609

correction, 328

hemodiafiltration and, 328, 608

diabetes and, 574

disorders of hemostasis and, 610–612

- ESA therapy for, 523–524
 - decreased response to, 600–604
 - dosing of, 596–598
 - Hgb results, 597*f*
- ESA therapy side effects and, 598–599
 - cancer, 599
 - effect on Kt/V, 599
 - graft clotting, 598–599
 - seizures, 598
 - stroke risk, 599
 - worsening of hypertension, 598
- ESKD, children and, 708–711
- etiology of, 592
- frequent hemodialysis and, 318
- hemolysis and, 609–610, 610*t*
- in infants and children, 710
- infections and, 606
- iron deficiency, 14–15
- management, frequent hemodialysis and, 318
- medications for, 593
- obstetric, gynecologic issues and, 742–743
- physical examination for, 592
- red blood cell transfusions and, 608
- resistance to ESAs and, 606
 - ACE inhibitors, 608
 - aluminum intoxication, 607–608
 - hyperparathyroidism, 606–607
 - inadequate dialysis, 607
 - inflammation and infection, 606
 - pure red cell aplasia, 608
 - vitamin B₁₂, 607
- symptoms of, 592
- target hemoglobin for, 595–596
- treatment for, 593–598
- uremia vs., 29

Angina, 226

Angiography

- magnetic resonance, 145

- vascular access, 145

Angiotensin-converting enzyme inhibitors (ACE), 608

- for chronic heart failure, 726

for chronic kidney disease, 9, 10

complications of, 347

for hypertension, 584–585, 587*t*

Angiotensin II receptor blockers (ARBs), 584–585, 588*t*

Anidulafungin, 645*t*, 661

Anthropometry, 537

Anti-glomerular basement membrane (GBM) disease, 334, 349

Antibiotics (antimicrobials)

arteriovenous fistula infections, 151

arteriovenous graft infections, 151

bacteremia, 616

calcific uremic arteriolopathy, 689

catheter-related bloodstream infection, 128, 131*t*, 156–164, 159–160*t*, 445

catheter splicing, 446

conjunctivitis, 573

cuffed hemodialysis catheter infections, 157*f*, 161*f*

dyslipidemia, 718

endocarditis, 731

exit site infection, 155, 447, 508–510, 509*t*

gynecologic neoplasms, 751–752

keratitis, 573

lock solutions, 133, 159*t*, 160*t*, 163*t*

neurotoxicity, 758–759

patients undergoing hemodialysis, 158*t*

pericatheter leak, 439, 516

peritonitis, 446, 460, 461, 496–500, 499*t*, 502–507

port clamp fracture, 170

prophylaxis, 113, 133–134, 426, 443, 617–618, 747

urine tract infections, 618–620

upper urine tract infections, 620–622

specific drugs, 294–296*t*, 385–386*t*, 387*t*, 629, 630–639*t*, 648–657

tunnel infection, 155, 508–510, 509*t*

Anticoagulant citrate dextrose (ACD), 342–343

Anticoagulation, 252, 327. *See also* citrate; heparin

assessment of, 252

heparin-free, 261*t*, 287–288

with lepirudin, 290–291, 291*t*

for NHD, 316–317

regional citrate, 265, 288–290

techniques, 263–266

heparin infusion, 256*f*, 257–259, 259*t*

therapeutic apheresis, 341–343

- Anticonvulsants, 382
- Antifungals, 644–647*t*, 660–661
 - amphotericin B, 644*t*, 645*t*
 - anidulafungin, 645*t*
 - caspofungin, 645*t*
 - fluconazole, 645*t*
 - flucytosine, 645*t*
 - griseofulvin, 645*t*
 - itraconazole, 645*t*, 646*t*
 - ketoconazole, 646*t*
 - micafungin, 646*t*
 - for peritonitis, CAPD, 498*t*
 - posaconazole, 646*t*
 - terbinafine, 646*t*
 - voriconazole, 646–647*t*
- Antihypertensive medications, frequent hemodialysis and, 317
- Antimicrobials, for peritonitis, 497–499, 498*t*, 499*t*
- Antineutrophil cytoplasmic antibody (ANCA)–associated vasculitis, 351
- Antiretrovirals, 641–644*t*, 658–660
- Antithrombin (AT), 255
- Antituberculars, 638*t*, 657
 - ethambutol, 638*t*
 - isoniazid, 509*t*, 638*t*
 - pyrazinamide, 638*t*
 - rifabutin, 638*t*
 - rifampin, 638*t*
- Antivirals, 640–641*t*, 657–658
 - acyclovir, 640*t*
 - adefovir, 641*t*
 - amantadine, 640*t*
 - boceprevir, 640*t*
 - cidofovir, 640*t*
 - famciclovir, 640*t*
 - foscarnet, 640*t*
 - ganciclovir, 640*t*
 - oseltamivir, 641*t*
 - ribavirin, 641*t*
 - rimantidine, 641*t*
 - valacyclovir, 641*t*
 - valganciclovir, 641*t*
 - zanamivir, 641*t*
- Aranesp. *See* Darbepoetin alfa (Aranesp)

- Argatroban, 265
- Arrhythmias, cardiovascular disease and, 732–734
- Arterial dilation test, 103–104
- Arteriography, 104
- Arteriovenous (AV) access, 276
- Arteriovenous (AV) fistulas, 99–110, 727
 - access planning, 101–102
 - cannulation of, 109–110, 115–118
 - early dysfunction, treatment for, 146
 - for hemodialysis access, 28
 - increased use of, guidelines targeting, 100–101
 - infections in, 151
 - ischemia in, 148, 149
 - maturation, perioperative care and, 108
 - neointimal hyperplasia in, 100
 - operative procedure for, 107–108
 - physical examination of, 114–115
 - preoperative evaluation, 102–104
 - pseudoaneurysm in, 150
 - stenosis in, 138*f*
 - thrombosis in, 147–148
 - upper extremity, location for, 104–107, 105*t*, 106*f*
 - vascular access, 184–185
 - vessel preservation, 101
- Arteriovenous (AV) grafts, 110–115, 185, 727
 - infections in, 151
 - locations, 111–113
 - maturation, 113
 - physical examination of, 114–115
 - postoperative care, 113
 - pseudoaneurysm in, 150
 - stenosis in, 138*f*
 - surgical placement, 113
 - thrombosis in, 148
- Arteriovenous vascular access monitoring and complications, 137–152
 - clinical outcome goals and monitoring, 152
 - congestive heart failure, 151–152
 - infections, 150–151
 - ischemia, 148–149
 - percutaneous intervention after stenosis identification, 145–147
 - percutaneous interventions, complication of, 152
 - pseudoaneurysm, 149–150

- stenosis, 137–145
- thrombosis, 147–148
- vascular access, imaging, 145

Ascorbic acid, 609

Aspirin, 723

- for cardioprotection in CKD, 10
- for *S. aureus*-related CRBSI, 164

Atazanavir, 641*t*, 659

Atlanto-cervical spondylopathy, 774

Atorvastatin, for dyslipidemia, 717*t*

Automated peritoneal dialysis (APD), 25, 418–422, 419*f*, 465*t*, 478. *See also* Continuous ambulatory peritoneal dialysis; Peritonitis, APD connections, 420–421

Automated peritoneal dialysis (APD) (*continued*)

- cyclers, 418–420
- with daytime exchanges, 422–423
- dialysis solution, 420
- sodium removal during, 488

Azathioprine, after therapeutic apheresis, 348

Azithromycin, 294, 635*t*, 653

Aztreonam, 294, 503, 504, 633*t*, 649–650

B

Back pain, 226

- from PD, 518

Bacterial infection, 615–623

Balance, 412*t*

Balloon angioplasty, for central venous stenosis, 169

Band keratopathy, and diabetes, 573

Barbiturates, 374–375

- for anxiety and behavior disorders, 531

Bath salts, 383–384

- poisoning, 383–384

Beta-blockers

- for cardioprotection in CKD, 10
- for hypertension, 587*t*

Bezafibrate, for dyslipidemia, 717*t*

Bicarbonate, 212

- adjusting dialysis solution, 364–365
- based solutions, 277, 364–365
- CRRT solutions, 280–281
- in dialysis fluid circuit, 73

in dialysis solution, 176–177, 262, 315, 741

laboratory tests, predialysis, 212

Bicavera, 412*t*

Bile acid sequestrants, for dyslipidemia, 717*t*

Biohazardous waste, 245

Bioimpedance analysis (BIA), 582

Biotin, for muscle cramping, 224

Birth control, 736–737

Bleach cleaning, 247

Bleeding. *See also* Hemorrhage

abnormal uterine, 745–748

anemia and, 605–606

intracranial, 754–755

resistance to ESAs and, 605–606

Blood circuit

air detector in, 188

air trap, pressure monitor, 67*f*, 69–70

inflow blood line of, 66–68

line kinking in, 188

postpump segment, 67*f*, 68–69

roller pump and, 67*f*, 68

Blood clotting

in extracorporeal circuit, 252, 253*t*

factors favoring, 252–253, 252*t*

measurement of, 254–255

Blood flow

hemodialysis prescription and, 172–174

peritoneal, 397

session length and, 196

Blood leak detector, 72

Blood pressure

cardiovascular disease and, 713

CKD and, 9–10

patient monitoring, 210

postdialysis, 578

Blood values, postdialysis, 189–190

potassium, 190

urea nitrogen, 190, 199*t*

Blood volume monitors, 75

Blood water urea clearance, computation of, 42–43

Body composition, 537–538

Body mass index, 537

Body surface area equations, 785

Body weight, 537

Bone disease, 598

- adynamic bone, 680

- alkaline phosphatase and, 683

- calcium and, 676–678

- calcium, phosphorus control and, 595–596

- in chronic kidney disease, 679–681

- cinacalcet dosing guidelines, 686

- diabetes and, 574

- hyperphosphatemia, control of, 667–673

 - dietary restriction, 667–668

 - phosphorus binders, 669–673, 670–671*t*, 673*t*

 - phosphorus removal, by dialysis, 668

 - residual kidney function, 669

- mixed lesions, 681

- osteitis fibrosa, 679–680

- osteomalacia, 680–681

- osteoporosis, 681

- parathyroidectomy, 687

 - chemical ablation and, 688

 - postoperative hypocalcemia, 688

 - surgical strategy for, 687–688

- pathophysiology of, 665–667

- phosphorus and, 667–676

- PTH assays and, 681–682

- PTH management and, 681–686

 - active vitamin D and D analogs, 684–686

 - dialysate, 595, 596

 - teriparatide, 686–687

 - vitamin D and calcimimetics, 686

- vitamin D analogs, 685*t*

 - calcitriol (Rocaltrol), 684, 685*t*

 - doxercalciferol (Hectorol), 684–686, 685*t*

 - paricalcitol (Zemplar), 684, 685*t*

- vitamin D dosing guidelines, 684, 686

Bone disorders, and cardiovascular disease, 720–721

Brain edema, 299–300

C

Calcific uremic arteriolopathy (CUA), 688–689

Calcijex. *See* Calcitriol

Calcitriol (Calcijex, Rocaltrol), 19, 665–666, 665–667, 678–679, 684, 685*t*

Calcium, 212, 545

bone disease and, 676–678

continuous renal replacement therapies, 280

dialysis solution, 740–741

Nocturnal HD and, 316

Calcium acetate, 670–671*t*

Calcium antagonists, 587*t*

Calcium carbonate, 670*t*, 674

Calcium channel blockers, 585–586

Calcium load, associated with phosphorus binders, 669, 672

Calcium phosphorus control, bone disease and, 595–596

Cambrooke Foods, 794*t*

Canagliflozin, for diabetes, 565*t*, 571

Cancer, ESA therapy and, 599

Carbamazepine, 767*t*

for epileptic seizure, 764, 766

poisoning, 382

Carbapenems/monobactams, 633–634*t*

Carbohydrates, 543, 550

Cardiac arrest, cardiovascular, disease and, 732–734

Cardiac glycosides, 727

Cardiac implantable electronic device (CIED), 101, 102

Cardiomyopathy, cardiovascular disease and, 725–727

Cardiopulmonary recirculation, solute transport, 56–57

Cardiovascular disease, 713–734

anemia, 721

arrhythmias and, 732–734

blood pressure, 713

bone disorders and, 720–721

cardiac arrest and, 732–734

cardiomyopathy and, 725–727

CKD and, 8–12

diabetes, 713

dyslipidemia, 714–719

heart failure and, 725–727

ischemic heart disease and, 722–724

left ventricular hypertrophy, 719–720

lipid-lowering medication and, 717*t*

mineral disorders and, 720–721

mineral metabolism, 720–721

- oxidant stress and inflammation, 722
- risk factors for, 713, 714*t*, 720–722
- sleep, 721
- smoking, 713
- stroke and, 734
- sudden cardiac death and, 732–734
- valvular calcification and, 731–732
- valvular disease and, 729–732
- valvular stenosis and, 731–732

Carnitine

- for cardiomyopathy, 727
- for hypotensive episodes, 224

Carpal tunnel syndrome, 772–774

Carvedilol, 585, 587*t*, 724, 726

Casino-Lopez approach, for urea removal, 60–61

Caspofungin, 645*t*, 661

- for candida infection, 158*t*

Cataracts, and diabetes, 573

Catheter adhesion, 170

Catheter dysfunction, 164–168

Catheter obstruction, peritonitis with, 506

Catheter-related bloodstream infection (CRBSI), 155–164

- complications of, 163–164

- ERBP treatment guidelines for, 161*f*

- IDSA treatment guidelines for, 157*f*, 158*t*, 159–160*t*

Catheters. *See also* Venous catheters

- abdominal, 427

- acute, 425–426

- acute complications of, 438–439

- alternative designs, 427–429

- break-in procedures, 437–438

- chronic, 426–429, 426*f*, 428*f*

- chronic peritoneal catheters

 - care of, 446–448

 - complications of, 439–446

- embedding procedure, 436–437, 436*f*

- extended, 435–436

- extended two-piece, 427

- for infants and children, 697*t*

- infection and management, 445–446

- irrigation, 437, 447

- manipulation, for outflow failure, 442–444

placement procedures, 431–437, 432*t*

removal and secondary embedding, 448–449

rigid noncuffed, 425

selection of

 patient factors influencing, 429, 430*f*

 stencil-based preoperative mapping, 429–431, 431*f*

soft noncuffed, 425–426

splicing, 445–446

Cefaclor, 631*t*

Cefadroxil, 631*t*

Cefazolin, 158*t*, 159*t*, 161, 294*t*, 507, 631*t*, 648, 731

 concentration in lock solutions, 163*t*

 for methicillin-resistant *Staphylococcus* infection, 161, 163*t*

 for peritonitis, 496, 497*t*, 498*t*, 499, 499*t*

 for vancomycin-resistant gram-positive infections, 618

Cefepime, 294*t*, 632*t*, 648–649

 for peritonitis, 6, 498*t*, 499*t*

Ceftaroline, 632*t*, 649

Ceftazidime, 294*t*, 632*t*

 concentration in lock solutions, 163*t*

 for peritonitis, 498*t*

 after therapeutic apheresis, 348

Ceftibuten, 633*t*

Ceftriaxone, 294*t*, 633*t*

 after therapeutic apheresis, 348

Cefuroxime, 633*t*

Cellulose membranes, 76–77

Centers for Disease Control

 dialysis bloodstream infection prevention, core interventions for, 131*t*

Central sleep apnea, 769

Central vein or intracardiac thrombosis, 168

Central venous catheterization, complications of, 129*t*

Central venous stenosis, 168–169

Centrifugal apheresis, 337–339, 338*f*

 comparison with membrane plasma separation, 337*t*, 340–341

Cephalexin, 509*t*, 633*t*

Cephalosporins, 631–633*t*

 cefaclor, 631*t*

 cefadroxil, 631*t*

 cefazolin, 498*t*, 631*t*

 cefdinir, 631*t*

 cefepime, 498*t*, 499*t*, 632*t*

- cefotaxime, 632*t*
- cefotetan, 632*t*
- cefoxitin, 632*t*
- cefpodoxime, 632*t*
- cefprozil, 632*t*
- ceftaroline, 632*t*
- ceftazidime, 294*t*, 498*t*, 632*t*
- ceftibuten, 633*t*
- ceftriaxone, 294*t*, 633*t*
- cefuroxime, 633*t*
- cephalexin, 633*t*
- cephalothin, 498*t*
- cephradine, 498*t*
- for methicillin-resistant *Staphylococcus* infection, 160
- for peritonitis, 498*t*

Cephalothin, for peritonitis, 498*t*

Cephradine, for peritonitis, 498*t*

Cerebral atrophy, 755

Cerebral perfusion/oxygenation, dialysis-induced reduction in, 758

Cerebrovascular disease, diabetes and, 572

Chemotherapy, for gynecologic neoplasms, 752

Chest pain, 226

- during hemodialysis session, 723–724

Children

- acute hemodialysis in, 695

- acute modality choice in, 694

- acute PD in, 694–695

- catheters for, 697*t*

- chronic hemodialysis and, 698–708

- continuous therapies for, 695, 697–698

- ESKD patient care for, 708–711

- acidosis in, 710–711

- anemia, 710

- growth, 710–711

- hypertension, 709–710

- renal osteodystrophy, 711

- hemofilters for, 697, 698*t*

- hypertension, 709–710

- indications for, 693–694

- low-volume dialyzers for, 696*t*

- PD and, 699–704

Chloramine, 89, 91, 92, 93, 94, 95, 232, 310, 361, 362*f*, 609, 610*t*

Chlorthalidone, for chronic kidney disease, 10

Cholesterol, 211

Cholestipol, for dyslipidemia, 717*t*

Cholestyramine, for dyslipidemia, 717*t*

Chronic dementia, 759

Chronic heart failure

AV fistulas, grafts, 727

cardiovascular disease and, 725–727

drug therapy for

ACE inhibitors, 726

aldosterone blocking agents, 726–727

aspirin, 723

cardiac glycosides, 727

L-carnitine, 727

Chronic kidney disease (CKD)

acetaminophen, 225

acid–base complications in, 19–20

aspirin for cardioprotection in, 10

beta-blockers for cardioprotection in, 10

blood pressure control in, 9–10

bone disease in, 679–681

cardiovascular disease and, 8–12

diabetes and, 10, 565–566*t*

electrolyte abnormalities in, 19–20

etiology of, 8

GFR measurement for, 4, 6–7, 9*t*

glycemic control in, 10

hyperphosphatemia in, 15–17, 19

hypertension and, 9

lipid-lowering therapy in, 10–12

protein restriction and, 12

screening for, 3–8

serum electrolytes in, 8

slowing progression of, 8–12

smoking cessation for, 9

stages of, 8, 9*t*

ultrasound and, 8

urinary protein in, 2–3

Chronic Kidney Disease-Mineral and Bone Disorder (CKD-MBD), 15–19, 16*f*

cinacalcet for, for CKD-MBD, 19

hyperphosphatemia in, 15–17

serum alkaline phosphatase in, 18

serum parathyroid hormone levels in, 17–18

vitamin D in, 18–19

Chronic obtundation, 759, 762*f*

Cidofovir, 640*t*, 658

Cinacalcet, for CKD-MBD, 19

Ciprofibrate, for dyslipidemia, 717*t*

Ciprofloxacin, 294*t*, 509*t*, 634*t*, 650

concentration in lock solutions, 163*t*

for peritonitis, 498*t*

Citrasate, 262

citrate, 270*f*. *See also* Regional citrate anticoagulation as anticoagulation solution, for therapeutic apheresis, 342–343

complications of, 345

-based solutions, 279

CKD-EPI GFR equation, 7

Clarithromycin, 636*t*, 653

for exit-site and tunnel infections, 509*t*

Clavulanate

plus amoxicillin, 629, 640

plus ticarcillin, 629, 640

Clearance, 39–43

indices

body size and, 472

in PD, 467–468, 468*t*, 469*t*, 471*t*

PET and, 472

prescription changes and, 472–473

of middle molecules, 327

other substances, 327–328

PET and, 403–405

of phosphate, 327

Clindamycin, 294*t*, 496, 617, 621, 638*t*, 639*t*

Clofibrate, for dyslipidemia, 717*t*

Clonidine, 589, 738

for diabetes, 586

for hypertension, 586

removal during dialysis, 587*t*

removed with hemoperfusion, 388

side effects of, 586

Closed connector devices, 308–309

Coagulation, visual inspection, 252

Coated membranes, 77–78

Cobicstat

plus elvitegravir, 642*t*, 660

plus emtricitabine, 642*t*

plus tenofovir, 642*t*

Cockcroft–Gault equation, 6

Cognitive dysfunction, 768

Colesevelam, for dyslipidemia, 717*t*

Colistimethate (Colistin), 638*t*, 650

Colistin. *See* Colistimethate (Colistin)

Complications

air embolism, 233

alkalemia, 373

angina, 226

back pain, 226

chest pain, 226

common, 215–226

continuous therapy, 374

dialyzer reactions

nonspecific, 231

type A, 229–231

disequilibrium syndrome, 226–228, 373

headache, 225

hemolysis, 231–232

hemoperfusion, 370

heparin, 259–260

hypophosphatemia, 373, 610*t*

hypotension

detection of, 221–222

management of, 222, 223*t*

unusual causes of, 221

IDPN, 549–550

infants and children, 707–708

itching, 226

muscle cramps, 222–225

nausea, vomiting, 225

during PD, 513–520

respiratory, 517–518, 518*t*

visual, hearing loss, 704

Composite indices, 538

Computed tomography (CT), for gynecologic neoplasms, 750–751

Concomitant immunosuppression, therapeutic apheresis, 333

Congestive heart failure, 151–152, 299

Coning, 758

Conjunctivitis, and diabetes, 573

Constipation

catheter complications and, 441

peritonitis and, 501

Constrictive pericarditis, 729

Contaminants, 89

Continuous ambulatory peritoneal dialysis (CAPD), 25, 465*t*, 478

dialysis solutions

buffer and pH, 410–411

electrolyte concentrations, 411

glucose, 408–410

non-glucose solutions, 413–414

volumes, 408

transfer sets, 414–417

Continuous equilibrated peritoneal dialysis (CEPD), 455–456

Continuous hemodiafiltration (C-HDF), 269*t*, 270–271, 271*f*

urea clearance with, 274–275

Continuous hemodialysis (C-HD), 268, 269*t*, 270*f*

drug dosage during, 294–295*t*

solute clearance with, 273

Continuous hemofiltration (C-HF), 269*t*, 270, 271*f*

solute clearance with, 273–274

urea clearance with, 284–285*t*

Continuous renal replacement therapy (CRRT). *See also* Renal replacement therapy

acute lung injury and, 300–301

for aminoglycoside removal, 651–652

antimicrobial dosing in, 295–296*t*

with AV access, 237–238

bicarbonate solution for, 280–281

brain edema and, 299–300

continuous hemofiltration and, 247

dose *vs.* outcome, 282

ECMO and, 301

empiric dosing, 283

equipment for, 283, 285, 286

filters for, 276–277

nomogram method, 283, 286*f*

prescribing, delivering, 282–283

radiocontrast-induced nephropathy and, 301

sepsis, multiorgan failure, 300

toxin, poisoning treatments and, 301

Continuous therapy, 374

complications, 374

Contraceptives, oral, for abnormal uterine bleeding, 747

Conversion tables, 799–801*t*

Corcoran-Salazar equation, 779–781, 781*f*

Coronary artery disease, and diabetes, 572

C-reactive protein (CRP), nutrition and, 539

Creatinine, 211

clearance, 465*t*

estimated, 6

by timed urine collection, 4–6

weekly, 467–468

excretion rate, expected 24-hour, 779, 779–780*f*

hematocrit clearance effect on, 42–43

K_0A and, 80

as nutritional index, 480

PD and, 469*t*, 477

renal clearance, 469*t*

urea *vs.*, 404

Cryofiltration, 357

Cryoglobulinemia, 350–351

Culture-negative peritonitis, 504–505

Cyclosporine, 758

for seizures, 763*t*

after therapeutic apheresis, 348

Cystatin C equations, 7

Cytomegalovirus, 627

D

Dabigatran, 257

and hemorrhage, 383

poisoning, 383

Daily dietary recommendations, 540*t*

Daily hemodialysis (DHD), 314

Dalfopristin plus quinupristin, 502, 639*t*

Dalteparin, use in continuous renal replacement therapies, 291

Danaparoid, 264

Dapagliflozin, for diabetes, 571

Dapsone, 639*t*

Daptomycin, 639*t*, 655–656

concentration in lock solutions, 163*t*

Darbepoetin alfa (Aranesp), 14

for anemia, 593, 596

- Darunavir, 642*t*, 659
- Deamino arginine vasopressin (DDAVP)
 - for abnormal uterine bleeding, 747
- Deficiency syndromes, hemodiafiltration and, 329, 330
- Delavirdine, 642*t*, 659
- Delirium, 531
- Demeclocycline, 636*t*, 679
- Dementia, 531, 759, 760*t*
 - chronic, 759, 760*t*
 - neurocognitive decline and, 766, 768
- Depo-Provera. *See* Medroxyprogesterone acetate
- Depression, 528–531
 - MAOIs for, 530
 - non-pharmacologic options for, 530–531
 - SNRIs and, 530
 - SSRIs and, 529–530
 - subclinical cognitive dysfunction and, 768
 - suicide, 528–529
 - TCAs for, 529–530
- Dextran, 604–605
- Dextrose solutions, fluid overload and, 486
- Diabetes, 555–574
 - anemia and, 574
 - blood sugar control and, 559–571
 - alteration in insulin metabolism, 559–561
 - abnormal glucose tolerance tests, 559
 - hyperglycemia, 560
 - hypoglycemia, 560–561
 - increased sensitivity to insulin, 559–560
 - bone disease and, 574
 - cardiovascular disease and, 713
 - cerebrovascular disease and, 572
 - CKD and, 10, 565–566*t*
 - coronary artery disease and, 572
 - dialysis initiation and, 555
 - dialysis modalities and, 556*t*
 - diet and, 557–558
 - AGEs, 558
 - carbohydrates percentage, 557
 - enteropathy and, 558
 - eye problems and, 572–573
 - retinopathy, 572–573

- gastroparesis and, 558
- hemodialysis vs. PD and, 555–557
- hyperkalemia and, 571
- hypertension, 571–572
- impotence and, 573
- insulin therapy, 561–563
- oral hypoglycemic agents, 564–571
 - α -glycosidase inhibitors, 567
 - insulin secretagogues, 564
 - metformin, 564–567
 - PPAR agonists, 567–568
- sulfonylureas, 564
- peripheral vascular disease and, 572
- transplantation and, 573–574

Dialysate

- composition, 315–316
- flow rate, K_0A impact by, 40–41
- genital edema and, 516
- magnesium, and muscle cramping, 224
- sodium, and muscle cramping, 224
- sodium, and hyponatremia, 208
- water quality, 330

Dialysis. *See also* Hemodialysis; Postdialysis

- access placement issues and, 28
- adolescents on, 28
- anticoagulant use during, 253–254
- dosage, 192–194
- early or timely initiation of, 29
- elderly patients and, 27–28
- fluid potassium level, 220
- gender and, 193
- home vs. in-center, 23*t*, 24
- initiation of, 185
- machines, frequent hemodialysis and, 310–311
- malnourished patients and, 194
- monitors
 - blood circuit, 186–188
 - dialysis solution circuit, 188–189
- patient education, 22
- patient monitoring, 185–189
 - access site, 210

- blood pressure, 210
- during session, 210–212
- temperature, 210
- weight, 209–210

patient size and, 193–194

peritoneal, 25–26

postdialysis evaluation, 189–190

postponing, 23*t*, 26

prescription adjustment, 200

session length, 194

termination of, 189

thrice-weekly, 192–193

ultrafiltration, 183–184

Dialysis and replacement solutions

- composition, 277, 278*t*, 279–280

- for slow continuous therapies, 226–227, 278*t*

- sterility of, 281

- temperature, 282

Dialysis disequilibrium syndrome, 759, 760*t*

Dialysis fluid circuit

- advanced control options, 70–76, 75*f*

- bicarbonate in, 73

- heating, degassing of, 71

- monitors and alarms, 71–72

- proportioning system, 70

- ultrafiltration control, 72–73

- water purification system of, 70

Dialysis Malnutrition Score, 538

Dialysis membranes, home hemodialysis, 308

Dialysis solution, 408–414, 412*t*

- acute hyperkalemia and, 179–180

- amino acid-containing, 480–481

- antibiotic stability in, 499–500

- APD, 420

- bicarbonate, 262, 741

- calcium, 221, 677–678, 740–741

- circuit monitors

 - conductivity, 188

 - hemoglobin, 189

 - temperature, 188

- composition, 172, 206*t*

 - bicarbonate concentration, 206–207

- calcium, 208
- dextrose, 208
- magnesium, 209
- potassium, 207–208
- sodium, 208

dextrose concentrations, 181, 420

electrolyte concentrations, 411

flow rate, 182, 206, 206*t*

GDPs, 408–410

glucose, 180, 408–410

hypomagnesemia, 181

hypophosphatemia, 182

icodextrin, 413, 487

intra-abdominal pressure and, 399*f*

pH, 410–411

potassium rebound, 179

potassium removal and, 180

preparation

- dry concentrates, 96–97

- dual-concentrate system for, 95–96

- final composition of, 97–98, 97*t*

- proportioning machines, 95

quality requirements for, 90–91

sodium, 741

- hypernatremia, 178–179

- hyponatremia, 177–178

standard composition of, 97*t*

sterility, trace metals, 414

temperature of, 182

ultrapure, 90–91

Dialyzer reuse

- albumin loss and, 248

- automated vs. manual systems, 237–238

- bleach cleaning, 247

- clinical issues, 244–248

 - bacterial/pyrogen contamination, 246

 - formaldehyde, 245

 - infectious agent transmission, 247

 - morbidity, mortality, 245

- cost, 249

- germicides and, 238–239

- heat sterilization, 243
- informed consent, 249
- labeling, 243
- personnel, physical plant, 250
- preprocessing
 - dialysis treatment, 238–239
 - postdialysis, 239
 - pre–first use, 238
- quality assurance, 249
- reprocessing technique, 237–244
- reverse ultrafiltration, 239, 240–241
- rinsing, 239, 240–241
- storage, 243–244

Dialyzers, 76–88

- access recirculation (AR) measurement, 55–56, 75*f*
- disinfection of, 98
- high-flux, 204
- K_0A of, 41*t*, 79–80
- membrane material and, 174
- reactions to
 - nonspecific, 231
 - type A, 229–231
- reuse. *See* Dialyzer reuse

Dialyzers (*continued*)

- session length calculation, 196
- specification sheet, interpreting, 78–88
- structure of, 76–78
- ultrafiltration coefficient for, 174–175
- urea clearance, 175

Diaminopyrimidines, 637*t*, 656–657

- pyrimethamine, 637*t*
- trimethoprim/sulfamethoxazole, 637*t*

Dianeal, 412*t*

Dicloxacillin, 630*t*

- for exit-site and tunnel infections, 509*t*

Didanosine, 642*t*, 659

Diet composition tables, 787

- phosphorus, 787, 792–794*t*
- potassium, 787, 788–791*t*

Diffusion

- clearance due to, 321

versus convection-based clearances, 321

Digoxin, 348, 371, 727

for chronic arrhythmias, 733

poisoning, 375

after therapeutic apheresis, 348

use in ICU, 297*t*

Dipeptidyl peptidase 4 (DPP-4) inhibitors, for diabetes, 569–571

Diphenhydramine, for plasmapheresis complications, 346*t*

Disequilibrium syndrome, 173, 226–228, 373, 757–758

Distal revascularization interval ligation (DRIL), 149

Doppler sonography

access flow rate measurement using, 143–144

vascular access, 145

Doppler ultrasonography, 102–104

Doripenem, 634*t*, 649

Double filtration plasmapheresis (DFPP), 357

Doxercalciferol (Hectorol), 19, 684–686, 685*t*

Doxycycline, 636*t*, 656

for diabetic enteropathy, 558

for urinary tract infection, 619, 621

Drugs

overdose, 354

removed with

hemodialysis, 385–387*t*

hemoperfusion, 387–388*t*

Dry weight, 205–206, 581

Dual energy x-ray absorptiometry (DEXA), 538

Dyslipidemia, 329

cardiovascular disease and, 714–719

drug therapy for, statins, 716–718

hemodiafiltration and, 329

E

Efavirenz, 642*t*, 659, 660

Elderly patients, dialysis for, 27–28

Electrolytes, 552

composition, 326–327

hemodiafiltration, 326–327

imbalances, 243

Elvitegravir, 660

plus cobicstat, 642*t*, 660

plus emtricitabine, 642*t*

plus tenofovir, 642*t*

Embolic complications, and thrombosis, 168

Emtricitabine, 642*t*, 659

plus cobicstat, 642*t*, 660

plus elvitegravir, 642*t*

plus tenofovir, 642*t*

Encapsulating Peritoneal Sclerosis (EPS), 519–520

End-dialysis hypertension, 583

End stage kidney disease (ESKD)

acidosis in, 710–711

anemia and, 710

hypertension and, 709–710

in infants and children, 708–711

renal osteodystrophy in, 711

End stage renal disease (ESRD), 24

therapies for, 24

Endocarditis, 729–731

Endogenous clearance, influence on poison dialyzability, 371

Endometrial ablation, for abnormal uterine bleeding, 748

Endotoxin, 90, 93, 94, 95, 156, 229, 230, 240, 281, 300, 310, 311, 325, 326, 330, 757

Endovascular stents

for pseudoaneurysm, 150

for vascular access stenosis, 146–147

Ener-G foods, 794*t*

Enfuvirtide, 642*t*, 659

Enoxaparin, 263*t*

use in continuous renal replacement therapies, 292

Entecavir, 624, 642*t*

Enteropathy, diabetes and, 558

Epileptic seizures, 759–760, 763–766, 763*t*, 765*f*

Epoetin alfa

for anemia, 13, 593, 596

for pure red cell aplasia, 608

Equilibrated Kt/V, 192

Equivalent urea clearance (EKRU), 60–61

Ertapenem, 634*t*, 649

Erythrocytes, urea and, 42

Erythromycin, 636*t*, 653

Erythropoiesis stimulating agents (ESA), 328

for anemia, 523–527, 533–535, 597*f*, 742–743

for CKD

frequency of administration, 14

Hb thresholds and, 13
route of administration, 14
types of, 13–14

consumption, hemodiafiltration and, 328

Estimated creatinine clearance (eCrCl), using Ix equation, calculation of, 777–778

Etexilate mesylate (Pradaxa), poisoning, 383

Ethambutol, 638*t*, 657

for culture-negative peritonitis, 505

Ethosuximide, 766, 767*t*

for epileptic seizure, 766

Exenatide, for diabetes, 566*t*, 568, 569

Exit-site infection, 155, 445–446, 507–510, 509*t*

Extended two-piece catheters, 427

Extracorporeal membrane oxygenation (ECMO), 301

Extracorporeal photopheresis (ECP), 357–358

Extraction ratio, 37–39

Extraneal, 412*t*

Eye problems, diabetes and, 572–573

Ezetimibe, 717*t*, 718, 719

for CKD, 11, 12

for dyslipidemia, 717*t*

for lipid abnormalities, 523

plus simvastatin, 716

plus statin, 716

F

Factor Xa-activated ACT, 255

Famciclovir, 640*t*, 657, 658

Fenofibrate, for dyslipidemia, 717*t*

Ferric citrate, 676

Ferric pyrophosphate citrate (Triferic), 605

Fibrin sheath, 166

Fibroblast growth factor 23 (FGF23), 665

Filters, 276–277

Filtration fraction, 274

Finger flexion contractures, 774

“Fire-and-forget” approach, 716

Fistula First initiative, 100, 101

Flucloxacillin, for exit-site and tunnel infections, 509*t*

Fluconazole, 294*t*, 645*t*, 660, 661

for candida infection, 158*t*

for exit-site and tunnel infections, 509*t*

for fungal peritonitis, 505

for peritonitis, 498*t*, 499*t*

Flucytosine, 505, 645*t*

exit-site and tunnel infections, 509*t*

Fludrocortisone

for complications during hemodialysis, 220–221

for hypotension, 488

Fluid absorption, in PD, 398–400

Fluid overflow, in PD, 483–488

Fluid overload

abdominal leaks, 486

catheter malfunction, 486

dextrose solutions and, 486

frequent clinical assessment, 486

good blood sugar control, 486

management of, 485–487

mechanisms of, 483

patient education and, 486

in PD patients, 483–488, 484*t*

sodium restriction for, 485

Fluid removal, 478

Fluid removal rate, 205–206

Fluid status, assessment of, 483

Fluoroquinolones, 634–635*t*, 650

ciprofloxacin, 294*t*, 498*t*, 509*t*, 634*t*

gemifloxacin, 634*t*

levofloxacin, 634*t*

moxifloxacin, 635*t*

ofloxacin, 635*t*

Fluvastatin, for dyslipidemia, 717*t*

Focal segmental glomerulosclerosis (FSGS), recurrent, 353

Folate supplementation, for anemia, 743

Fondaparinux, 254, 264

for heparin-induced thrombocytopenia, 260

Food intake assessment, 536

Formaldehyde

acute reactions to, 245

dialyzer reuse and, 245

Fosamprenavir, 642*t*, 659

Foscarnet, 640*t*, 658

Frequent hemodialysis

anemia management, 318

- antihypertensive medications and, 317
- dialysis machines, 310–311
- dialysis membranes, 308
- infrastructure requirements, 310–311
- nocturnal HD, 314–315, 314*t*
- nutrition and, 318
- patient safety, 308–310
- phosphorus, 315–316
- prescription recommendations, 314–315
- quality of life with, 317
- SDHD, 314–315, 314*t*
- technical considerations, 307–310
- training, 307
- vascular access, 307–308
- water supply, 310

Fresenius 2008 sorbent system, 365–366

Fresenius PAK sorbent hemodialysis system, 366, 366*f*

Fresh frozen plasma (FFP), 333

- as replacement solution, 343–344, 343*t*

Fungal peritonitis, 505

G

Gabapentin, for anxiety and behavior disorders, 531

Ganciclovir, 294*t*, 640*t*, 641*t*, 658

Gastroparesis, 225

- diabetes and, 558

GBM. *See* Anti-glomerular basement membrane disease

Gemfibrozil, for dyslipidemia, 717*t*

Gemifloxacin, 634*t*

Genital edema, 516–517

Genitourinary tract, urinary tract infections in, 618–622

Gentamicin, 133, 294*t*, 496, 510, 635*t*, 651–652

- concentration in lock solutions, 163*t*

- for endocarditis, 730

- for exit-site care, 447, 510

- for hemodialysis patients, 651

- for IP aminoglycoside toxicity, 503

- for long-term catheter care, 447

- for peritoneal dialysis patients, 651

- for peritonitis, 498*t*

- resistant *S. aureus*, 502

- stability of, in dialysate, 499–500

for trough aminoglycoside levels, 652–653

use in CRRT, 651–652

plus vancomycin, 163*t*

Geriatric Nutritional Risk Index (GNRI), 538

Glaucoma, and diabetes, 573

Glipizide, for diabetes, 564, 565*t*, 570

Glomerular filtration rate (GFR)

to body surface area, normalizing, 777

in CKD, 3, 7, 9*t*

CKD-EPI set for, 778–779

Glucagon-like peptide-1 (GLP-1) receptor agonists, for diabetes, 568–569

Glucoseabsorption, 517, 542–543

continuous renal replacement therapies, 280

dialysis solution, 408–410

monitoring, for diabetes, 562

-sparing strategies, for PD, 478

Glucose degradation products (GDPs), 408–410, 409*f*, 410–411

Glutethimide, 369*t*

Glycopeptides, 636*t*, 654–655

telavancin, 636*t*

vancomycin, 295*t*, 498*t*, 499*t*, 636*t*

α -Glycosidase inhibitors, 567

Glycylcyclines, 656

Gonadotropin releasing hormone agonists, for abnormal uterine bleeding, 747

Gotch approach, to urea removal, 61–62

Griseofulvin, 645*t*

Guanabenz

for diabetes, 586

hypertension and, 586

Gynecologic issues. *See* Obstetric and gynecologic issues

H

Haloperidol

for anxiety and behavior disorders, 531

use in ICU, 297*t*

Headache, 225

Hearing loss, visual and, 704

Hectorol. *See* Doxercalciferol (Hectorol)

Helicobacter pylori, 623

HELLP syndrome, 739

Hematocrit

blood water urea clearance effect of, 42

creatinine clearance effect by, 43

phosphorus clearance effect by, 42–43

Hematologic complications, of therapeutic apheresis, 346

Hematopoietic stem cells (HPSC) transplantation, 358

Hemodiafiltration (HDF), 36, 321–330

basics of, 321–326

blood flow rates, 322

convective therapies

alternative, 330

clinical benefits of, 327–329

issues to, 330

diffusion versus convection-based clearances, 321

electrolyte composition, 326–327

versus hemodialysis, 328–329

mixed-dilution online, 322–324, 323*f*

modalities, advantages and shortcomings of, 324*t*

postdilution online, 322–324, 322*f*

predilution online, 322–324, 323*f*

prescription of, 326–327

solute clearance with, formulas for, 322*t*

Hemodialysis (HD). *See also* Continuous hemodialysis; Frequent hemodialysis; Intermittent hemodialysis; Peritoneal dialysis

access placement issues in, 28

apparatus, 81–87*t*. *See also* Dialyzers

blood circuit of, 66–70

dialysis fluid circuit of, 70–76

conventional, 306, 317

daily, short, 24–25

effect on insulin dose, 562

frequency of, 25, 306

home vs. in-center therapy for, 25

indication for, in chronic setting, 29–30

long, frequent, 318–319

long nocturnal, 25

modality choice in, 22–28

prescription

blood flow rate, 172–174

frequency, 173–174

session length, 172–174

urea distribution volume and, 173

session, chest pain during, 723–724

short and standard frequent, 318

Hemodynamic complications, of therapeutic apheresis, 345–346

Hemofilters, specifications of, 81–87*t*

Hemofiltration, 36

- anticoagulation, 262

Hemolysis, 231–232, 610*t*

- anemia and, 609–610
- chloramine and, 610*t*
- hypersplenism and, 610*t*
- hypophosphatemia and, 373, 610*t*

Hemolytic reactions, 95

Hemoperfusion (HP), 369*t*, 370

- poisoning, 387–388*t*

Hemorrhage, dabigatran-associated, 383. *See also* Bleeding

Henoch–Schönlein purpura (HSP), 353

Heparin, 68, 69, 247, 256*f*, 259*t*, 270*f*, 287–288, 287*t*, 460. *See also* Tight heparin as anticoagulation

- solution, for therapeutic apheresis, 341
- complications, 259–260
- free dialysis, 261–262, 261*t*, 287–288
- for nocturnal HD, 316–317
- peritonitis and, 500
- for SDHD, 316–317

Heparinoids, 264

Hepatitis A, 623

Hepatitis B, 247, 623–625

Hepatitis C, 247, 625–627

Hernia

- in PD patients, 513–515, 514*t*
- risk factors for, 513*t*

High-flux hemodiafilter, 325

High-volume peritoneal dialysis (HVPD), 456

Home hemodialysis, 23*t*, 24, 25

Hormone replacement therapy (HRT), 746–747

Human immunodeficiency virus (HIV), 247, 627–628

25-Hydroxycholecalciferol (25-D)

- optimizing serum levels of, 678–679

Hydrothorax, 517–518, 518*t*

- surgical options for, 518*t*

Hypercalcemia, 677

- acute, 180–181
- dialytic treatment of, 180–181

Hyperglycemia, 461, 521–522

- diabetes and, 560

Hyperkalemia, 260, 524, 571

acute, 179–180

subacute, 180

Hypernatremia, 178–179, 461, 525

Hyperparathyroidism, 17, 212, 606–607

Hyperphosphatemia

in CKD, 15–17, 19

control of, 667–673

dietary restriction, 667–668

phosphorus binders, 669–673, 670–671*t*, 673*t*

phosphorus removal, by dialysis, 668

residual kidney function, 669

Hypersplenism, 610*t*

Hypertension

ACE inhibitors, 584–585, 587*t*

adrenergic modulators, 587–588*t*

anemia, ESA therapy and worsening, 598

antihypertensive medications, frequent hemodialysis and, 317

ARBs for, 584–585, 588*t*

β -, α/β -, and α -adrenergic blockers, 585

beta-blockers, 587*t*

BIA for, 582

calcium antagonists, 587*t*

calcium channel blockers, 585–586

CKD and, 9

clonidine, 586

common clinical problems in, 582–583

excessive ultrafiltration, 582–583

postdialysis blood pressure, 578

recurrent hypertension, 583

definition, measurement of, 578–579

diabetes, 571–572

drug therapy and, 579*t*

dry weight, 581

emergencies, 589–590

end-dialysis, 583

ESKD and, 709–710

fluid correction for, 581–582

guanabenz and, 586

in infants and children, 709–710

intradialysis, 583

methyldopa and, 586

- in PD, 488
- during pregnancy, 738–739
- salt correction for, 581–582
- sodium restriction for, 580–581
- ultrafiltration and, 582–583
- vasodilators, 588–589, 588*t*

Hypertonic solutions, 223–224

Hypertriglyceridemia, management of, 718

Hyperviscosity syndrome, 353

Hypoalbuminemia, 461–462

Hypocalcemia, 677

Hypoglycemia, diabetes and, 560–561

Hypokalemia, 524

- therapeutic apheresis and, 348

Hypomagnesemia, 181

Hyponatremia, 177–178, 525

Hypophosphatemia, 182, 373, 610*t*

Hypotension

- detection of, 221–222

- intradialytic, 215

- management of, 222, 223*t*

- in PD, 488

- unusual causes of, 221

Hysterectomy, for abnormal uterine bleeding, 748

I

Icodextrin, 398

Ideal body weight (IBW) equations, 783

IgA nephropathy, 353

Imidazoles, 660

Imipenem, 294*t*, 634*t*

Immune function, derangement of, 615

Immunizations, 629

Immunoabsorption columns, 355–357, 356*f*

Immunoglobulin removal, pharmacokinetics of, 334–337

- extravascular distribution and equilibration rate, 334–335, 334*t*

- macromolecule reduction ratio, 335–336, 335*t*

- plasma half-life, 334

- plasma volume, estimation of, 336–337

- reaccumulation, 336

- TPE prescriptions, pharmacokinetic basis for, 336

Impotence, diabetes and, 573

In-center hemodialysis, 23*t*, 24, 25

Indinavir, 643*t*

Infants

acute hemodialysis in, 695

acute modality choice in, 694

acute PD in, 694–695

catheters for, 697*t*

chronic hemodialysis and, 698–708

continuous therapies for, 695, 697–698

ESKD patient care for, 708–711

acidosis in, 710–711

anemia, 710

growth, 710–711

hypertension, 709–710

renal osteodystrophy, 711

hemofilters for, 697, 698*t*

hypertension, 709–710

indications for, 693–694

low-volume dialyzers for, 696*t*

PD and, 699–704

Infections, 150–151. *See also* Viral infection

aminoglycosides for, 635*t*, 650–651

amikacin, 294*t*, 498*t*, 635*t*, 652

gentamicin, 294*t*, 498*t*, 510, 635*t*, 651–652

monitoring levels of, 652–653

streptomycin, 635*t*, 652

tobramycin, 295*t*, 498*t*, 499*t*, 635*t*, 651–652

anemia and, 606

antifungals for, 644–647*t*, 660–661

antiretrovirals for, 641–644*t*, 658–660

antituberculars for, 638*t*, 657

antivirals for, 640–641*t*, 657–658

in AV fistulas, 151

in AV grafts, 151

bacterial, 615–623

carbapenems/monobactams for, 633–634*t*

catheter-related bloodstream, 155–164

cephalosporins for, 631–633*t*

control practices, 625*t*

daptomycin for, 655

diaminopyrimidines for, 637*t*, 656–657

- drug dosages for, 552*t*
- exit-site, 155
- fluoroquinolones for, 634–635*t*, 650
- glycopeptides for, 636*t*, 654–655
- glycylcyclines, 656
- Helicobacter pylori*, 623
- immune function and, 615
- immunizations recommended for, 629
- increased susceptibility to, 615
- intra-abdominal, 622
- linezolid for, 655
- listeriosis, 623
- macrolides and ketolides for, 635–636*t*, 653–654
- miscellaneous antibiotics for, 638–639*t*
- mucormycosis, 623
- nervous system and sleep disorders, 757
- peritonitis, 490
- pneumonia, 622
- salmonella* septicemia, 623
- temperature control and, 616
- tetracyclines for, 636–637*t*, 656
- tuberculosis, 622–623
- tunnel, 155
- urinary tract, 618–622
- vaccination, 628–629
- vancomycin-resistant Gram-positive, 618
- venous catheter, 155–164
- viral, 623–628
 - cytomegalovirus, 627
 - hepatitis A, 623
 - hepatitis B, 623–625
 - hepatitis C, 625–627
 - HIV, 247, 627–628
 - influenza, 627
 - mononucleosis, 627
- Yersinia* septicemia, 623

Inflammation

- nervous system and sleep disorders, 757

Influenza, 627

Insulin, 460

- combinations, 561–562

dose

hemodialysis effect on, 562

peritoneal dialysis effect on, 563

infusion pump, 563

mealtime, timing of, 562

regimens, 561

Intensive care unit (ICU)

common drugs, adult dosage of, 297–298*t*

Intermittent hemodialysis (IH), 268, 269*t*

Intermittent peritoneal dialysis (IPD), 454–455

Intra-abdominal infection, 622

Intracranial bleeding, 754–755

Intradialysis hypertension, 583

Intradialytic hypotension (IDH), 215

Intradialytic symptoms, 328

hemodiafiltration and, 328

Intradialytic total parenteral nutrition (IDPN), 549–550

Intraluminal thrombosis, 168

Intraperitoneal hydrostatic pressure, 399

Intravenous immunoglobulin (IVIG) therapy, 354

Iron deficiency, 600*t*

anemia, 14–15

dextran, 604–605

intravenous iron drugs and, 604–605

intravenous iron safety and, 604

anaphylaxis, 604

infection, 604

oxidation, 604

Iron sucrose, 605

Iron therapy, for anemia, 743

Ischemia, 148–149

Ischemic heart disease, 722–724

Ischemic stroke, 754–755

Isolated ultrafiltration (IU), 296

Isoniazid, 638*t*, 657

for culture-negative peritonitis, 505

for exit-site and tunnel infections, 509*t*

Isotope dilution mass spectrometry (IDMS), 4, 6, 7

Itching, 226

Itraconazole, 645*t*, 646*t*, 660, 661

for fungal peritonitis, 505

Ix equation, 6

K

Keratitis, and diabetes, 573

Ketoconazole, 646*t*

K_0A . *See* Mass transfer area coefficient

L

Labor and delivery, 743–744

Laboratory tests, predialysis

albumin, 211

bicarbonate, 212

calcium, 212

creatinine, 211

phosphorus, 211

potassium, 211

total cholesterol, 211

urea nitrogen, 210–211

Lactate-based solutions, 277

Lamivudine, 643*t*

plus abacavir, 660

Lanthanum carbonate, 671*t*, 675

Laparoscopy, 435

LDL apheresis, 354–355

Lean body weight equations, 785

Lee-White clotting time (LWCT), 255

Left ventricular hypertrophy, 719–720

Lepirudin, 290–291, 291*t*

Leukoaraiosis, 755–756

Levofloxacin, 294*t*, 634*t*, 650

Levonorgestrel intrauterine system (Mirena), for abnormal uterine bleeding, 746

Leypoldt equation, 796

Limbic abnormalities, 523

Linagliptin, for diabetes, 570

Linezolid, 295*t*, 502, 639*t*

for catheter-related infection, 159*t*

concentration in lock solutions, 163*t*

for exit-site and tunnel infections, 509*t*

for infections, 655

for peritonitis, 498*t*

Lipase, peritonitis and, 501

Lipid-lowering therapy, in CKD, 10–12

Lipids, 543–544, 551

Liraglutide, for diabetes, 566*t*, 568, 569

Listeriosis, 623
Lithium, for anxiety and behavior disorders, 531–532
Lithium carbonate, 380–381
Liver disease, 212
Long nocturnal hemodialysis, 25
Lopinavir plus ritonavir, 643*t*, 659*t*
Lorazepam
 for anxiety and behavior disorders, 531
 use in ICU, 297*t*
Lovastatin, for dyslipidemia, 717*t*
Low-molecular weight heparin (LMWH)
 hemodialysis using, 263, 263*t*
 use in continuous renal replacement therapies, 291–292
Lower gastrointestinal X-ray series, for gynecologic neoplasms, 750
Lower inflammatory profile, hemodiafiltration and, 328

M

Macroalbuminuria, 3
Macrolides and ketolides, 635–636*t*, 653–654
 azithromycin, 635*t*
 clarithromycin, 636*t*
 erythromycin, 636*t*
 telithromycin, 636*t*
Macromolecule reduction ratio (MRR), 335–336
Maddy's low-protein store, 794*t*
MagneBind, 672
Magnesium
 calcium binders, 675
 continuous renal replacement therapies, 280
Magnesium carbonate, 670–671*t*
Male reproductive organs. *See* Genitourinary tract
Malnutrition, 480–481
 hemodiafiltration and, 329
Malnutrition Inflammation Score, 538
Malnutrition Screening Tool (MST), 537
Malnutrition Universal Screening Tool (MUST), 537
Maraviroc, 643*t*, 660
Marital issues, 532
Mass transfer area coefficient (K_0A)
 computation of, 42
 creatinine clearance and, 80
 dialysate flow rate impact on, 41–42

β_2 -microglobulin clearance and, 80

phosphate clearance and, 80

urea clearance and, 79–80

vitamin B₁₂ clearance and, 80

Mass transfer area coefficient (MTAC), 40–42, 40*t*, 41*f*, 396–397

Med Diet, Inc., 794*t*

Medroxyprogesterone acetate (Depo-Provera), for abnormal uterine bleeding, 747

Meglitinides, for diabetes, 565*t*, 568

Membrane plasma separation (MPS), 339–340, 340*f*

comparison with centrifugal apheresis, 337*t*, 340–341

Membranes

cellulose, 76–77

coated, 77–78

efficiency *vs.* flux, 78

frequent hemodialysis and, 308

Membranes (*continued*)

permeability of, 78

protein-losing, 78

synthetic, 76

Meprobamate, 369*t*

Meropenem, 295*t*, 634*t*, 649

Metabolic acidosis, 8, 19, 177, 277, 280, 288, 373, 374, 375, 376, 377, 378, 379, 380, 384, 454, 456, 524–525, 535, 547, 551, 571, 693, 710

Metabolic alkalosis, therapeutic apheresis and, 348

Metformin

for diabetes, 564–567, 565*t*

poisoning, 384

Metformin-associated lactic acidosis (MALA), 373, 384

Methaqualone, 369*t*

Methenamine, 619, 639*t*

Methyldopa

for diabetes, 586, 588

for hypertension, 586, 738

3,4-Methylenedioxypropylvalerone (MPDV), 383

3,4-Methylenedioxy-*N*-methylamphetamine (MDMA), 383–384

Metronidazole, 295*t*, 621, 637*t*

for exit-site and tunnel infections, 509*t*

for polymicrobial peritonitis, 504

Micafungin, 646*t*, 661

Microalbuminuria, 3

Microbubbles, 292

β_2 -Microglobulin amyloidosis

hemodiafiltration and, 329

hemodialysis therapy and, 329

β_2 -Microglobulin clearance, K_0A and, 80

Midodrine

for complications during hemodialysis, 220

for hypotension, 223*t*, 488

Miglitol, for diabetes, 565*t*, 567

Mineral

disorders, and cardiovascular disease, 720–721

metabolism, abnormalities in, 525–526

supplementation, continuous renal replacement therapies and, 292

trace elements, 552

Mini Nutritional Assessment (MNA), 537

Minocycline, 636*t*, 656

Mircera, for anemia, 593, 596

Mirena. *See* Levonorgestrel intrauterine system (Mirena)

Miscellaneous antibiotics, 638–639*t*

Mixed apneas, 769

Mixed dilution, 322–324, 323*f*, 324*t*

Modification of Diet in Renal Disease (MDRD) equation, 6–7

Moisture detectors, 309

Molecular weight, influence on poison dialyzability, 371

Monitoring. *See also* Patient monitoring

frequent dialysis, 309–310

levels of, 652–653

overnight remote, 311

Monoamine oxidase inhibitors (MAOIs), 530

for depression, 530

Mononucleosis, 627

Morbidity benefits, 329

hemodiafiltration and, 329

Mortality benefits, 329

hemodiafiltration and, 329

Moxifloxacin, 635*t*, 650

Mucormycosis, 623

Multiple myeloma, 351–352

Mupirocin, 308, 617

for BSI prevention, 131*t*

for exit-site infection, 133–134, 155, 447, 508, 509, 510

for long-term catheter care, 447

for nasal decolonization, 134, 503

for *S. aureus* infection, 503

for tunnel infection, 508, 509, 510

Muscle cramps, 222–225

Mushroom poisoning, 381

N

Nadroparin, 263*t*

use in continuous renal replacement therapies, 292

Nafamostat maleate, 254, 266

Nafamostat mesylate, in continuous renal replacement therapies, 292

Nafcillin, 295*t*, 629, 630*t*

for endocarditis, 730, 731

for peritonitis, 496, 498*t*

Nateglinide, for diabetes, 565*t*, 568

National Kidney Foundation, Kidney Disease Outcomes Quality Initiative, 100

Nausea, vomiting, 225

Nelfinavir, 643*t*, 659

Neointimal hyperplasia, 100

Neomycin, 635*t*

for BSI prevention, 131*t*

Nervous system and sleep disorders, 754–775, 759*t*

acute aluminum intoxication, 756–757

acute obtundation syndrome, 759, 759*t*, 761*f*

atlanto-cervical spondylopathy, 774

carpal tunnel syndrome, 772–774

central sleep apnea, 769

cerebral atrophy, 755

chronic dementia, 759, 760*t*

chronic obtundation, 759, 762*f*

cognitive dysfunction, 768

coning, 758

dementia, 760*t*

dialysis disequilibrium syndrome, 759, 760*t*

disequilibrium syndrome, 757–758

epileptic seizures, 759–760, 763–766, 763*t*, 765*f*

finger flexion contractures, 774

infection and inflammation, 757

intracranial bleeding, 754–755

ischemic stroke, 754–755

leukoaraiosis, 755–756

metabolic and electrolytic causes of, 756–757

mixed apneas, 769

neuropathy, 772–774, 772*t*

- obstructive sleep apnea, 769
- restless leg syndrome, 769–771
- seizures, 759–766
 - anticonvulsant drugs for, 766, 767*t*
 - management of, 764
 - phenytoin, 764
 - predisposing factors for, 759, 764
 - prevention of, 764
- silent cerebral infarcts, 755
- sleep apnea, 769
- Status epilepticus*, 758–759
- transplantation and, 771
- treatment for, 770–771
- uremic encephalopathy, 756
- visual/auditory disturbances, 704

Nestle Nutrition, 794*t*

Net fluid removal, PD, 402–403

Netilmicin

- for IP aminoglycoside toxicity, 503
- for peritonitis, 498*t*

Neurocognitive decline, and dementia, 766, 768

Neuropathy, 772–774, 772*t*

Nevirapine, 643*t*, 659

Nicotinic acid, for dyslipidemia, 717*t*

Nitrofurantoin, 639*t*

- for urinary tract infection, 619

Nitroimidazoles, 637*t*

- metronidazole, 637*t*

- tinidazole, 637*t*

Nocturnal hemodialysis (NHD)

- anticoagulation for, 316–317

- calcium depletion in, 316

- frequent hemodialysis, 314–315, 314*t*

- heparin protocols for, 316–317

- phosphorus binders and, 315–316

- SDHD *vs.*, 305

Nocturnal intermittent peritoneal hemodialysis (NIPD), 465*t*, 466

Nomogram method, for CRRT, 283, 286*f*

Non-glucose solutions, 413–414

Nonconvulsive *Status epilepticus*, 758–759

Nonsteroidal anti-inflammatory agents, for abnormal uterine bleeding, 747

Normalized protein nitrogen appearance rate (nPNA), 58–59, 59*t*

as nutritional index, 479–480, 479*t*

Normoalbuminuria, 3

Nutrineal, 412*t*

Nutrition, 535–553. *See also* Malnutrition

amino acids, 550–551

assessment of, 536–539

bioimpedance in, phase angle and, 537–538

DEXA, 538

food intake, 536

laboratory tests, 538–539

clinical utility of the nPNA, 539

CRP, 539

PNA, 539

predialysis SUN, 44, 47, 48*f*, 49*f*, 50–55, 54*f*, 538–539

UNA, 539

physical examination, 536

continuous total parenteral, 550–552

creatinine excretion and, 480

dietary requirements and, 540–546

calcium, 545

daily dietary recommendations, 540*t*

determination of energy requirements, adjustment factors for, 546*t*

dialysis adequacy, 541–542

energy, 542–543

glucose absorption, 517, 542–543

lipid requirements, 547

lipids, 543–544

need for individualization of, 541

peer rather than actual body weight, choice of, 541

percent carbohydrates, 543

phosphorus, 545

potassium, 544–545

protein, 542

protein requirements, 547

sodium and water, 544

vitamins

fat-soluble vitamins, 545–546

water-soluble vitamins, 545

IDPN, 549

composition, infusion and complications, 549–550

potential risks, 550

indices of

nPNA, 479–480, 479*t*

subjective global assessment (SGA) of, 407

intraperitoneal infusion of amino acids in peritoneal dialysis patients, 552

KDW in chronic dialysis patients, causes of, 536*t*

nPNA and, 479–480, 479*t*

nutritional supplements, 548–549

oral supplements, 549

screening tools for, 537

serum albumin, 480, 538

serum prealbumin, 539

TPN, 550–552

carbohydrates, 550

composition of typical solution, 550*t*

electrolytes, 552

Nutrition (*continued*)

lipids, 551

minerals and trace elements and, 552

vitamins, 552

Nystatin, peritonitis and, 500

O

Obstetric and gynecologic issues, 745–746

abnormal uterine bleeding and, 745–748

anemia and, 742–743

dyspareunia and, 744–745

gynecologic neoplasms, 749–752

HRT and, 748–749

labor and delivery and, 743–744

pregnancy and, 739–742

hypertension during, 738

hypertensive crisis, 739

sexual dysfunction and

birth control, 736–737

pregnancy, 737–743

dialysis regimen, 739–742

Obstructive sleep apnea, 769

Obtundation syndrome

acute, 759, 759*t*, 761*f*

chronic, 762*f*

Ofloxacin, 503, 635*t*

for culture-negative peritonitis, 505

for exit-site and tunnel infections, 509*t*

Olanzapine, for anxiety and behavior disorders, 531

Oseltamivir, 641*t*, 657

Osteitis fibrosa, 679–680

Osteomalacia, 680–681

Osteoporosis, 681

Overfill, 518–519

Oxacillin, 629, 630*t*

for peritonitis, 498*t*

Oxazepam, 224

Oxidative stress, hemodiafiltration and, 329

P

PA21, 675–676

Pain, chronic, management of, 774–775

Palliative care, 26–27

Paraquat, poisoning, 369*t*, 381–382

Parathyroid hormone (PTH), 212

active vitamin D and D analogs, 684–686

assays, 681–682

bone disease and management of, 681–686

dialysate, 595, 596

lowering or raising, methods of, 683–684

PTH assays, 681–682

serum, 16–17

target values, 682–683

teriparatide, 686–687

vitamin D and calcimimetics, 686

Parathyroidectomy, 687–688

Paricalcitol (Zemplar), 19, 684, 685*t*

Patient education

arteriovenous access planning, 101–102

for dialysis, 22

Patient monitoring

access site, 210

blood pressure, 210

during session, 210–212

temperature, 210

weight, 209–210

Peginesatide, for anemia, 593

Pelvic ultrasonography, for gynecologic neoplasms, 751

Penicillin G, 295*t*, 630*t*

Penicillins, 630*t*

amoxicillin, 498*t*, 509*t*, 630*t*

ampicillin, 498*t*, 630*t*

dicloxacillin, 630*t*

nafcillin, 630*t*

oxacillin, 630*t*

peritonitis, 498*t*

piperacillin, 631*t*

ticarcillin, 631*t*

Peracetic acid, 241

Percutaneous needle–guidewire technique, 433–434

Percutaneous venous cannula, 184

Percutaneously inserted central catheter (PICC), 101, 102

Pericardial disease

constrictive pericarditis, 729

dialysis-associated pericarditis, 727–729

purulent pericarditis, 729

uremic pericarditis, 728

Pericarditis, 727–729

Pericatheter leak, 515–516

Peripheral vascular disease, and diabetes, 572

Peritoneal clearance, 403–405

Peritoneal creatinine clearance, 469*t*

Peritoneal dialysis (PD), 25–26, 465*f*, 467. *See also* Automated peritoneal dialysis; Continuous ambulatory peritoneal dialysis; Nocturnal intermittent peritoneal hemodialysis for acute kidney injury, 451–462

advantages and disadvantages of, 452*t*

complications of, 460–462

indications, 451–453

infrastructure of, 462

prescribing and dosing of, 456–460

sample orders, 457*t*

technical aspects of, 453–456

effect on insulin dose, 563

glucose-sparing strategies, 478

hyperglycemia and, 521–522

hyperkalemia and, 524

hyponatremia and, 525

hypokalemia and, 524

hyponatremia and, 525

limbic abnormalities and, 523

- metabolic acidosis and, 524–525
- mineral metabolism abnormalities and, 525–526
- peritoneal protein loss and, 522–523
- types of, 25
- weight gain, impact of, 522

Peritoneal equilibration test (PET), 400–402, 472

Peritoneal fluid, 492–495

Peritoneal membrane

- dysfunction, diagnosis of, 484–485
- histology, 393
- preservation of, 486

Peritoneal support

- diffusion, 396–397
- distributed model, 395–396, 395*f*
- models of, 394–396
- physiology of, 396–400
- three-pore model, 394–395, 394*f*
- ultrafiltration, 397–398, 397*f*
- ultrapores, 395

Peritoneal transport

- net fluid removal, 402–403, 403*f*
- PET, 400–402, 472

Peritonitis, 461, 515

- amylase and, 501
- APD, antimicrobials for, 497–498, 498*t*, 499, 499*t*
- catheter infection–related, 446
- with catheter obstruction, 506
- constipation and, 501
- culture-negative, 504–505
- diagnosis, 492–495, 492*t*
- dialysis solution calcium levels and, 491
- etiology of, 491
- fungal, 505
- heparin and, 500
- host defenses and, 491
- incidence of, 490
- infection routes of, 490–491
- initial management of, 496, 497*t*
- lipase and, 501
- nystatin and, 500
- peritoneal fluid and, 492–495
- polymicrobial, 504

- recurrent, 506
- refractory, 505–506
- relapsing, 506
- repeat, 506
- secondary, 500–501
- treatment of, 496, 497, 497*t*, 498*t*, 499–500, 499*t*

Peroxisome proliferator-activated receptor agonists (PPAR), 567–568

pH value, of peritoneal dialysis solution, 408–411

Pharmacokinetics, of immunoglobulin removal, 334–337

Phenobarbital, 298*t*

- after therapeutic apheresis, 348

Phenobarbital, for epileptic seizure, 766, 767*t*

Phenothiazines, poisoning, 382

Phenytoin, 348

- for epileptic seizure, 763*t*, 764, 766, 767*t*

- poisoning, 382

- prophylaxis of, 764, 766

- use in ICU, 298*t*

Phosphate

- clearance, 80, 668

- continuous renal replacement therapies, 280

Phosphorus, 211, 545

- binders, 16–17, 315–316, 669–673, 670–671*t*, 673*t*

- bone disease and, 667–676, 686–687

- calcium acetate and, 670–671*t*, 674

- calcium carbonate and, 670*t*, 674

- foods high in, 668*t*

- foods with, 668*t*

- frequent hemodialysis and, 315–316

- hematocrit clearance effect on, 42–43

- lanthanum carbonate and, 671*t*, 675

- magnesium binders and, 675

- magnesium carbonate and, 670–671*t*

- nutrition and, 545

- predialysis, 211

- removal, by dialysis, 668

- removal of, 80, 668

- sevelamer carbonate and, 671*t*, 674–675

Phosphorus binding equivalent dose (PBED), 669

Physical examination, nutrition assessment, 536

Physioneal, 412*t*

Pioglitazone, for diabetes, 565*t*, 567, 568

Piperacillin, 503, 631*t*, 648
Pleurodesis, 517–518
Pneumonia, 622
Poisoning, 354
 acetaminophen, 374
 anticonvulsants, 382
 aspirin, 374
 barbiturates, 374–375
 bath salts, 383–384
 carbamazepine, 386*t*, 387*t*
 chloral hydrate, 386*t*, 387*t*
 dabigatran, 383
 digoxin, 375
 diphenhydramine, 387*t*
 ethchlorvynol, 386*t*, 387*t*
 glutethimide, 386*t*, 387*t*
 hemodialysis for, 369*t*, 385–387*t*
 hemoperfusion for, 387–388*t*
 lithium carbonate, 380–381
 meprobamate, 386*t*
 metformin, 384
 methaqualone, 386*t*
 methyprylon, 386*t*
 mushroom, 381
 paraquat, 381–382
 phenothiazines, 382
 phenytoin, 382
 sedatives, 386–387*t*
 sodium valproate, 382
Poisoning (*continued*)
 thallium, 384–385
 theophylline, 382–383
 toxic alcohols, 375–380, 378*t*
 toxicokinetics, 370–371
 tricyclic antidepressants, 382
Polymicrobial peritonitis, 504
Polysomnography, 769, 770
Polytetrafluoroethylene (PTFE), 99
Port clamp fracture, 170
Posaconazole, 646*t*, 660, 661
 for fungal peritonitis, 505
Postdialysis

blood values, 189–190

patient evaluation, 189–190, 239–241

supplements, 661–662

urea nitrogen sample, 190, 199*t*

Postdilution, 322–324, 322*f*, 324*t*

Postponing dialysis, 23*t*, 26

Potassium, 190, 207–208, 211, 459, 544–545

continuous renal replacement therapies, 279

rebound, 179

Pradaxa. *See* Etexilate mesylate (Pradaxa), poisoning

Pramlintide, for diabetes, 565*t*, 571

Pravastatin, for dyslipidemia, 717*t*

Predialysis

phosphorus, 211

serum urea nitrogen (SUN), 44, 47, 48*f*, 49*f*, 50–55, 54*f*, 538–539

Predilution, 322–324, 323*f*, 324*t*

mode, 274

Prednisone

for complications during plasmapheresis, 346*t*

after therapeutic apheresis, 348

Preemptive transplantation, 22, 23*t*

Pregnancy, 737–743

weight gain during, 742

Primidone, for epileptic seizure, 766, 767*t*

Product water

contaminants, 89–90

purifying methods, 91–95

Prostanoids, 266

Protein, 542, 547

-bound compound removal, in hemodialysis, 36

-losing membranes, 78

binding, influence on poison dialyzability, 371

equivalent, of total nitrogen appearance, 539

loss, 330

hemodiafiltration and, 329

in PD, 405–406

peritoneal, 522–523

restriction, CKD, 12

Protein nitrogen appearance (PNA), 44

Pruritus, 226

management algorithm for, 227*f*

Pseudoaneurysm, 149–150

in AV fistulas, 150

in AV grafts, 150

Purulent pericarditis, 729

Pyocystis, 621–622

Pyogenic complications, upper urinary tract infections and, 620–621

Pyrazinamide, 638*t*, 657

for culture-negative peritonitis, 505

for exit-site and tunnel infections, 509*t*

Pyrimethamine, 637*t*

Pyrogenic reactions, 95

Q

Quinine therapy, 224–225

Quinolones, for peritonitis, 498*t*

Quinupristin plus dalfopristin, 502, 639*t*

R

Radiocontrast-induced nephropathy, 301

Raltegravir, 643*t*, 660

Recurrent peritonitis, 506

Red blood cell life span, ESA resistance and, 606

Red-eye syndrome, and diabetes, 573

REDY system, 365

Refractory peritonitis, 505–506

Regional blood flow model, 53

Regional citrate anticoagulation (RCA), 264–265, 288–290

Relapsing peritonitis, 506

Renal creatinine clearance, 469*t*

Renal osteodystrophy

in ESKD, 711

in infants and children, 711

Renal replacement therapy, 22–27

complications of, 30*t*

Renal transplantation, 354–355

Renin–angiotensin aldosterone system (RAAS) antagonists, 19

Repaglinide, for diabetes, 565*t*, 568

Repeat peritonitis, 506

Residual renal function, 59–60, 328, 471–472

hemodiafiltration and, 328

PD and, 406

preservation of, 486

Residual renal urea clearance, 194

Respiratory acidosis, 177
Restless leg syndrome, 769–771
Reticulocyte hemoglobin content (CHr), 602
Retinopathy, 572–573
Ribavirin, 641*t*
 for hepatitis C infection, 626, 627
Rifabutin, 638*t*
Rifampin, 295*t*, 638*t*, 657
 for culture-negative peritonitis, 505
 for endocarditis, 730, 731
 for exit-site infection, 508, 509, 657
 for nasal carriage infection, 503
 removed with hemodialysis, 386*t*
 for *S. aureus* infection, 502, 503, 657, 730
 for tunnel infection, 508, 509, 509*t*
Rigid noncuffed catheters, 425
Rilpivirine, 643*t*, 659, 660
Rimantadine, 641*t*, 657
Risperidone, for anxiety and behavior disorders, 531
Ritonavir plus lopinavir, 643*t*
Rocaltrol. *See* Calcitriol
Rosiglitazone, for diabetes, 565*t*, 567–568
Ross Nutrition, 794*t*
Rosuvastatin
 for dyslipidemia, 717*t*
 for reduced GFR, 717*t*
 for renal insufficiency, 12
Rule of sixes, 108

S

Salicylates, 348, 564
 poisoning, 369, 369*t*, 371, 374, 382
 after therapeutic apheresis, 348
Salmonella septicemia, 623
Saquinavir, 644*t*, 659
Saxagliptin, for diabetes, 565*t*, 569, 570
Secondary peritonitis, 500–501
Sedatives and hypnotics, 386–387*t*
Seizures, 598, 759–766
 anticonvulsant drugs for, 766, 767*t*
 management of, 764
 phenytoin and, 764

predisposing factors for, 759, 764

prevention of, 764

Selective norepinephrine reuptake inhibitors (SNRIs), 530

depression and, 530

Selective serotonin reuptake inhibitors (SSRIs), 529–530

for anxiety and behavior disorders, 531

depression and, 529–530

Sepsis, multiorgan failure, 300

Sertraline

for complications during hemodialysis, 220

for hypotension, 223*t*

Serum albumin, 480, 538

Serum alkaline phosphatase, 17

Serum calcium, optimizing, 676–678

of 25-hydroxycholecalciferol, 678–679

Serum creatinine, 4

Serum ferritin, 601

Serum prealbumin, 539

Serum total alkaline phosphatase, 683

Serum urea nitrogen (SUN), 172

computation of, 44–45, 47, 48*f*, 49*f*, 50–55, 54*f*

predialysis, 538–539

Sevelamer carbonate, 671*t*, 674–675

phosphorus and, 671*t*, 674–675

Sexual dysfunction, 532, 672–676, 745

Short daily hemodialysis (SDHD), 24–25

blood flow rates in, 314

frequent hemodialysis, 314, 314*t*

heparin protocols for, 316–317

nocturnal HD *vs.*, 314, 314*t*

Sieving, 398

Silent cerebral infarcts (SCI), 755

Simvastatin

for CKD, 12

for dyslipidemia, 716, 717*t*, 718, 719

for lipid abnormalities, 523

Single blood pathway devices, 76

Sitagliptin, for diabetes, 566*t*, 569–570

Sleep apnea, 769

Sleep disorders. *See* Nervous system and sleep disorders

Slow continuous therapies, 268, 269*t*, 271*f*

clinical indications, 272–273

dialysis and replacement solutions for, 226–227, 278*t*

differences among, 273–275

filters for, 276–277

training, equipment costs of, 273

types, 268, 269*t*, 270*f*, 271*f*, 272*t*

Slow continuous ultrafiltration (SCUF), 269*t*, 271, 299

Smoking, 713

CKD and, 9

Socioeconomic issues, 532

Sodium, 544

adjusting dialysis solution, 363–364

dialysis solution, 741

fluid overload and, 485

hypertension and, 581

removal, PD and, 401*f*, 405

Sodium ferric gluconate, 605

Sodium glucose co-transporter 2 inhibitor, for diabetes, 571

Sodium valproate, 382

Soft noncuffed catheters, 425–426

Solute clearance

with C-HD, 273

with C-HF, 273–274

Solute removal

from dialyzer perspective, 36–43, 37*f*

from patient perspective, 44–55

Solute transport

access recirculation, 55–56, 75*f*

cardiopulmonary recirculation, 56–57

diffusion, 34, 35*f*

ultrafiltration, 34–36, 35*f*

urea and, 44–45, 49*f*, 50, 52*f*

Sorbent-based dialysis machines, 365–367

Sorbent cartridge, 361–363

structure of, 362*f*

Sorbent dialysis, 360–365

Spectinomycin, 639*t*

Stable coronary artery disease, 723

Statins

cardioprotective effects of, 11–12

for dyslipidemia, 716–718, 717*t*

for hypertriglyceridemia, 718

Stavudine, 644*t*

Stay safe, 412*t*

Steal syndrome, 148, 149

Stenosis

central venous, 168–169

vascular access, 137–145, 138*f*

access blood flow rate, periodic measurements of, 141–143

access flow rate measurement using Doppler sonography, 143–144

access recirculation, 145

access surveillance, 139, 141

endovascular stents for, 146–147

identification, percutaneous intervention after, 145–147

intra-access pressure and access flow, 144–145

physical examination, 139, 140*t*

Stents

for central venous stenosis, 169, 169*f*

endovascular, for vascular access stenosis, 146–147

Streptomycin, 635*t*, 652

Stroke, 734

ESA therapy and, 599

Subclinical brain structural abnormalities, 755–756

Subclinical cognitive dysfunction, 768

Subjective global assessment (SGA), 538

Sucroferric oxyhydroxide (Velphoro), 675–676

Sudden cardiac death, 732–734

Suicide, 528–529

Sulfonylureas, 564

Superimposed preeclampsia, 739

Surface-area normalized values (SAN), in urea kinetic modeling, 797

Surgical dissection, for catheter placement, 434–435

Sustained, low-efficiency dialysis (SLED), 269*t*, 272, 283

Sustained low-efficiency dialysis and hemodiafiltration (SLED-F), 283

Swartz protocol, 289–290, 289*f*, 290*t*

Sympatholytic drugs, for diabetes, 586, 588

Systemic lupus erythematosus (SLE), 352–353

T

Target hemoglobin for anemia, 595–596

Tattersall equation, 796

Telaprevir, 644*t*

Telavancin, 636*t*, 655

Telbivudine, 644*t*

Telithromycin, 636*t*, 653, 654

Temperature control, derangement of, 616

Tenofovir, 642*t*, 644*t*, 659

plus cobicstat, 642*t*, 660

plus elvitegravir, 642*t*

plus emtricitabine, 642*t*

Terbinafine, 646*t*

Teriparatide, 681, 686–687

Tetracyclines, 636–637*t*, 656

demeclocycline, 636*t*

doxycycline, 636*t*

minocycline, 636*t*

tetracycline, 637*t*

Thallium, 384–385

poisoning, 384–385

Theophylline

poisoning, 369*t*, 370, 382–383

for seizures, 763*t*

use in ICU, 298*t*

Therapeutic apheresis (TA), 333–358

anticoagulation, 341–343

complications of, 345–348, 346*t*

strategies for avoiding, 346*t*

cryofiltration, 357

double filtration plasmapheresis, 357

extracorporeal photopheresis, 357–358

immunoabsorption columns, 355–357, 356*f*

immunoglobulin removal, pharmacokinetics of, 334–337

indications for, 348–354, 348*t*

LDL apheresis, 354–355

rationale for, 333–334, 354

replacement solution for, 343–345

stem cell transplantation, 358

technical considerations for, 337–341

vascular access, 341

Therapeutic plasma exchange (TPE), 333

mechanisms of action, 334*t*

prescriptions, pharmacokinetic basis for, 336

Thiazides, for chronic kidney disease, 9–10

Thrombin inhibitors, 265

Thrombosis

in AV fistulas, 147–148

in AV grafts, 148

central vein or intracardiac, 168

embolic complications and, 168

intraluminal, 168

Thrombotic thrombocytopenic purpura (TTP), 333

Thrombotic thrombocytopenic purpura–haemolytic uremic syndrome (TTP/HUS), 344, 349–350

Ticarcillin, 631*t*, 648

for urinary tract infection, 619

Tidal peritoneal dialysis (TPD), 421–422, 456, 466

Tight heparin, 258–259. *See also* Heparin

Tinidazole, 637*t*

Tipranavir, 644*t*, 659

Tissue plasminogen activator (tPA), for occluded catheters, 166*t*

Tobramycin, 295*t*, 635*t*, 651–652

for hemodialysis patients, 651

for IP aminoglycoside toxicity, 503

for peritoneal dialysis patients, 651

for peritonitis, 498*t*, 499*t*

after therapeutic apheresis, 348

for trough aminoglycoside levels, 652–653

use in CRRT, 651–652

Total body water anthropometric equations, 785–787, 786*f*, 787*f*

Total parenteral nutrition (TPN), 550–552, 550*t*

Toxic alcohols, 375–376, 375–380, 377*t*

Toxicokinetics, poisoning, 370–371

Transfer sets, 414–417

Y set, 415–416, 415*f*

Transferrin saturation, 601

Transmembrane pressure (TMP), 174

Transvaginal ultrasound, for gynecologic neoplasms, 751

Tricyclic antidepressants (TCAs), 382, 529–530

for depression, 529–530

Triferic. *See* Ferric pyrophosphate citrate (Triferic)

Trimethoprim, 656

Trimethoprim/sulfamethoxazole, 637*t*, 656

for exit-site and tunnel infections, 509, 509*t*

for gram-negative organism cultured, 503

for peritonitis, 498*t*

for urinary tract infection, 619, 620

Tuberculosis, 622–623

Tunnel infection, 155

Two-pump, single-needle system, 309

U

Ultrafiltered volume, 326

Ultrafiltration, 183–184. *See also* Slow continuous ultrafiltration

anticoagulation, 262

coefficient for, 174–175

concentration gradient for, 397–398, 397*f*

control of, dialysis fluid circuit, 72–73

failure of, 484–485

hydrostatic, 35, 37*f*

hypertension and, 582–583

osmotic, 35

peritoneal support, 397–398, 397*f*

programmable, 73–74

purpose of, 35–36

solute clearance and, 36

solute transport and, 34–36, 35*f*

Ultrafiltration failure (UFF), 484–485

transport status and, 487

Ultrapores, 395

Ultrasound, CKD and, 8

Unroofing–cuff shaving, 445

Urea

creatinine vs., 404

erythrocytes and, 42

hemodialysis prescription and, 173

K_0A and, 40*t*, 79–80

as marker solute, 192–196

removal vs. serum level, 192

solute transport and, 44–45, 49*f*, 50, 52*f*

Urea clearance. *See also* Blood water urea clearance

with C-HDF, 274–275

with C-HF, 284–285*t*

guidelines for, 193

measurement of, 469–470

weekly, 467

Urea distribution volume, modeling of, 57–58

Urea kinetic modeling, 795–797

dialyzer blood clearance, 795

solute transport in, 34–36

Leypoldt equation, 796

SAN values, 797

- Tattersall equation, 796
- Urea nitrogen, 37, 39, 40*t*, 190, 210–211
 - generation rate, 58–59
 - postdialysis, 190, 199*t*
- Urea nitrogen appearance (UNA), 539
- Urea reduction ratio (URR), 192
- Urea removal, 173
 - Casino-Lopez approach, 60–61
 - fixed volume model of, 48*f*, 49*f*
 - Gotch approach, 61–62
 - indices of, 44–55, 48*f*, 49*f*, 52*f*
 - measures of, 192
- Uremic pericarditis, 728
- Uremic syndrome, 28–30
 - poisoning, 369*t*, 385–387*t*
 - procedure
 - dialyzer rinsing, priming, 184
 - vascular access, 184
 - protein-bound compound removal in, 36
- Urinary protein, in CKD, 2–3
- Urinary retention, catheter complications and, 441
- Urinary tract infection, 618–622
- Urine albumin-to-creatinine ratio (UACR), 2, 3, 8
- Urine dipstick evaluation, limitations of, 2–3, 3*t*

V

- Vaccination, 628–629
- Valacyclovir, 641*t*, 657, 658
- Valganciclovir, 641*t*, 658
- Valproic acid
 - for anxiety and behavior disorders, 532
 - for anxiety disorder, 532
 - for behavior disorder, 532
 - for epileptic seizure, 766
 - prophylaxis of, 766, 767*t*
 - after therapeutic apheresis, 348
- Valvular calcification, 731–732
- Valvular disease, endocarditis, 729–731
- Valvular stenosis, 731–732
- Vancomycin, 295*t*, 636*t*, 654
 - resistant gram-positive, 618
 - concentration in lock solutions, 163*t*

Vancomycin (*continued*)

plus gentamicin, 163*t*

for methicillin-resistant *Staphylococcus* infection, 160, 163*t*

for peritonitis, 498*t*, 499*t*

Vascular access, 325

arteriovenous blood access, 276

arteriovenous fistula, 184–185

catheter changes, 276

frequent hemodialysis and, 307–308

therapeutic apheresis, 341

types of, 99–101

venovenous blood access, 275–276

Vascular access stenosis, 137–145, 138*f*

access blood flow rate, periodic measurements of, 141–143

access flow rate measurement using Doppler sonography, 143–144

access recirculation, 145

access surveillance, 139, 141

endovascular stents for, 146–147

identification, percutaneous intervention after, 145–147

intra-access pressure and access flow, 144–145

physical examination, 139, 140*t*

Vasculitis, antineutrophil cytoplasmic antibody–associated, 351

Vasodilators, hypertension for, 588–589, 588*t*

Vasopressin, 208

for complications during hemodialysis, 221

deamino arginine, 747

for intradialytic hypotension, 222

Vein dilation test, 103

Velphoro. *See* Sucroferric oxyhydroxide (Velphoro)

Venography, 104

Venous catheters, 173

access, 121–134

acute analysis of, 122–125, 123*t*, 124*f*

care and use of, 129–134

infections and complications, 155–170

air embolism on removal, 168

catheter adhesion, 170

catheter dysfunction, 164–168

central venous stenosis, 168–169

infection, 155–164

port clamp fracture, 170

thrombosis, 168

insertion-related complications, 129

insertion technique, 125–128

types and design of, 122

Venovenous blood access, 275–276

Vigabatrin, for epileptic seizure, 766, 767*t*

Viral infection, 623–628

cytomegalovirus, 627

hepatitis A, 623

hepatitis B, 623–625

hepatitis C, 625–627

HIV, 247, 627–628

influenza, 627

mononucleosis, 627

Visual loss, hearing and, 704

Vitamin B₁₂

clearance, K₀A and, 80

deficiency, ESA resistance and, 607

Vitamin D, 18–19

analogs, 685*t*

calcitriol (Rocaltrol), 684, 685*t*

doxercalciferol (Hectorol), 684–686, 685*t*

paricalcitol (Zemplar), 684, 685*t*

calcimimetics and, 686

dosing guidelines for, 684, 686

for ESA resistance, 607

receptor activators, 684–686

Vitamins, 552. *See also individual vitamins*

fat-soluble vitamins, 545–546

supplementation, continuous renal replacement therapies and, 292

water-soluble vitamins, 545

Vomiting, nausea, 225

Voriconazole, 295*t*, 646–647*t*, 661

for fungal peritonitis, 505

for infections, 660, 661

W

Waist–hip ratio (WHR), 537

Warfarin, 118, 564

-associated coagulopathies, 383

for catheter dysfunction, 166

for central venous stenosis, 169

- for chronic arrhythmias, 733, 734
- for heparin-induced thrombocytopenia, 260
- for intraluminal thrombosis, 168
- for stroke, 734
- for thrombosis, 147, 148

Water, 544

purification

- deionization, 93–94
- distribution, 95
- pretreatment, 91–93
- primary, 93–94
- reverse osmosis, 93
- safety standards for, 95

quality, 325–326

Weight gain

- effects in peritoneal dialysis, 522
- during pregnancy, 742

Whole-blood partial thromboplastin time (WBTT), 254

Y

Yersinia septicemia, 623

YTEC procedure, 434

Z

Zanamivir, 641*t*, 657

Zemplar. *See* Paricalcitol (Zemplar)

Zidovudine, 644*t*, 658

- plus abacavir, 660

- plus lamivudine, 660